

Questionnaire for Price Quotation for a Stationary Trash Rack Cleaner

I. Contact Data

PROJECT NAME
(please reference on all correspondence)

PROJECT SITE
(location and country)

Contact name Company

Address

ZIP code / City Country

Phone Mobile

E-mail Web

Developer Consulting Agency Name of Project Owner

II. Status

Feasibility study Contract pending; construction scheduled for:

Public tender Deadline for submitting an offer:

Construction of a new power plant Modernisation of an existing plant

III. Technical data

A Screen inclination °

B Screen pedestal in

C Roof projection in

D Height of roof in

E Height of apron in

G Distance to gate in

H Height of pedestal in

L Screen length in

T Water depth min. in

max. in

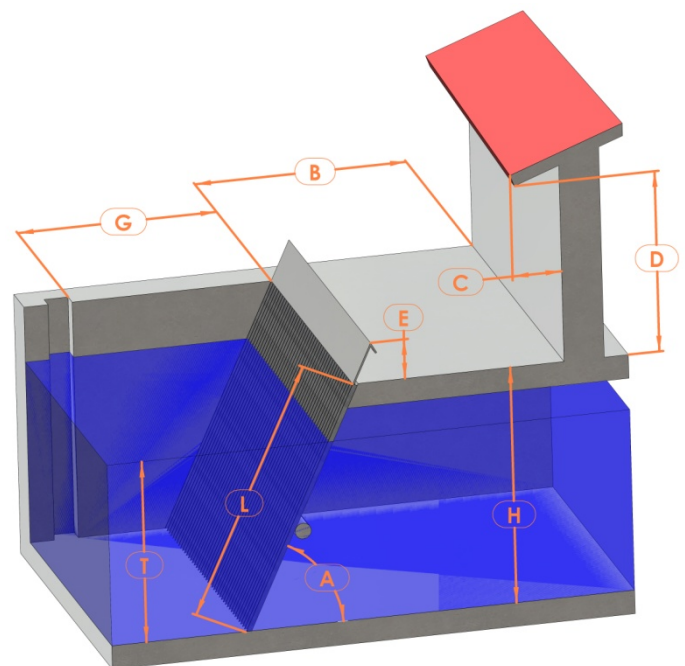

Tension V

Frequency Hz

Outside temperature between 14°F and 104°F yes no; temperature from °F to °F

Screening disposal Conveyor Wash-out channel

W Inlet width in

Spacing of screen bars in

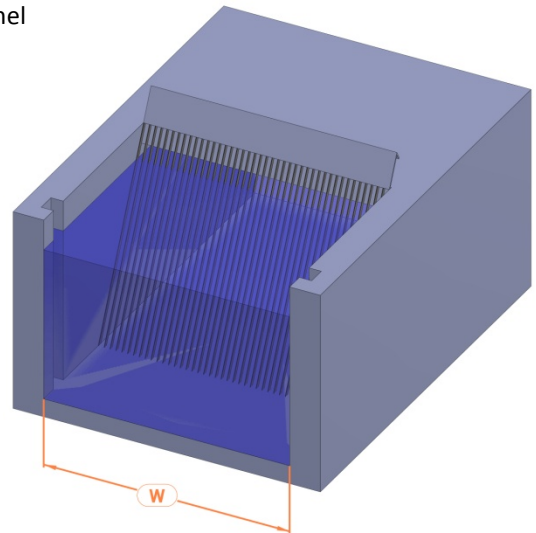

IV. Comments

Date, place

Signature

**OSSBERGER HYDRO
USA & CANADA**

1940 Flint Lock Ct
Powhatan, Virginia 23139
Tel: 804 360 7992

7774 Boyer, Montreal
QC, H2R2S2
Tel: 514 525 8430
Cell: 438 880 5655

info@ossbergerhydro.com
www.ossbergerhydro.com



OSSBERGER GmbH + Co. KG

Otto-Rieder-Strasse 5-11
91781 Weißenburg / Bavaria
GERMANY
+49 (0) 91 41 / 9 77-0

info@ossberger.de
www.ossberger.de