



2003-2017 Gen V Viper Window Boss Kit

Overview:

The threaded spacers that attach the driver and passenger side window to the window regulator are constructed from plastic and are prone to breakage. The DSE window boss kit completely replaces these parts with ones constructed from stainless steel and aluminum for durability.

Compatibility:

Gen III, IV, and V Vipers (2003-2017)

Construction:

6061 T6, Black Hard Anodized Aluminum, Delrin, Stainless Steel, and Viton Rubber (gasket).

Ordering Information:

<http://dougshelbyengineering.com/Viper.html>

DSE-VP-WB-001: Gen III, IV, and V Window Boss Kit (1 or 2 windows)



2 Window DSE Boss Kit



DSE (Left) vs. OEM (Right) Window Boss, inside of window facing upward

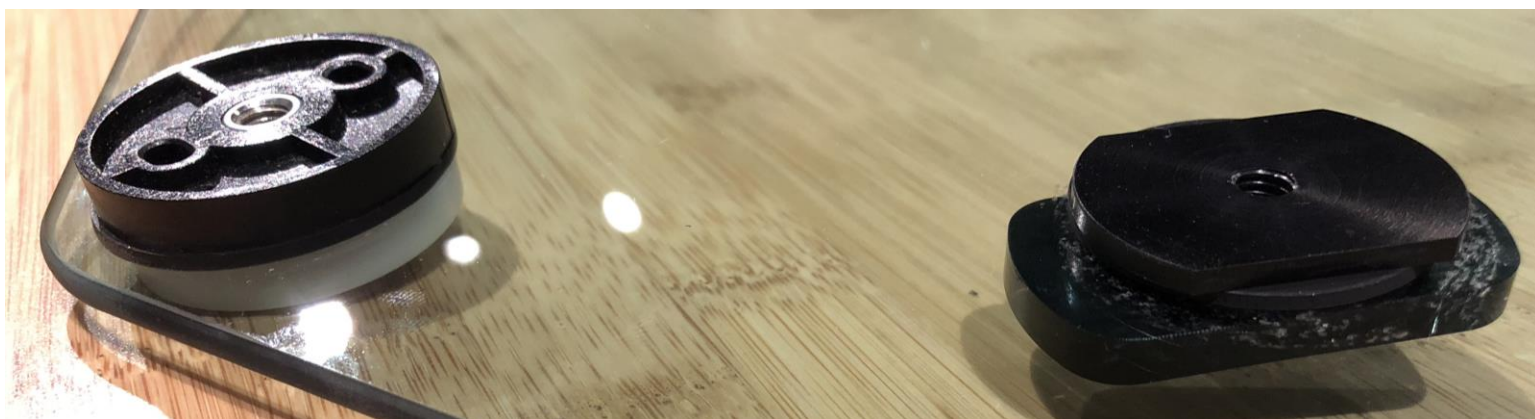

OEM (Left) vs. DSE (Right) Window Boss, outside of window facing upward

Installation Guide:

- Installation of the window bosses can be completed with the window installed or removed from the vehicle. See the service manual for your particular model year for instruction on accessing the window and regulator.
- Remove the OEM boss. Twist the plastic pieces apart. The pieces thread together using a left handed thread. Discard or keep the OEM parts but they will no longer be needed.
- Prepare the window boss kit for installation. Note the black plastic with stainless insert replaces the OEM white spacer on the inside of the window. The aluminum piece replaces the OEM black part on the outside of the window.

- The stack up of the DSE window boss should be as follows (inside window to out):
 - Stainless steel nut and black plastic spacer
 - Window Glass
 - Gasket
 - Threaded aluminum piece
- To install in the window place the black plastic/stainless piece into the hole on the inside of the window. If the window is upright (still installed in the vehicle) hold the stainless steel piece in place so it does not fall out.
- Apply Loctite to the *external / male* threads on the aluminum part. Place the gasket on the aluminum piece and insert on the opposite side (outside) of the window to thread into the stainless steel nut.
- Tighten the two pieces together by hand or by using an adjustable wrench. Hold the gasket so that it remains relatively centered between the aluminum piece and window glass. The diameter is roughly the same as the rounded aluminum section. Do not tighten so much that the aluminum threads protrude above the stainless steel nut.
- When installing the M6 bolts that hold the window to the window regulator, ensure the two pieces don't twist apart during tightening (keep your hand or a wrench on the aluminum part), especially if the Loctite has not had ample time to cure.

Overview of replacement while the window is installed on a Gen V (see service manual for other model years):

- Remove the door panel
- **EXCERPT FROM THE GEN V SERVICE MANUAL-**
- Disconnect and isolate the battery negative cable.
- Using a trim stick [C-4755](#) or equivalent, remove the interior release handle trim bezel (4) and remove the screw (3).
- Using trim stick or equivalent, remove the pull handle bezel (1) and remove the screw (2).

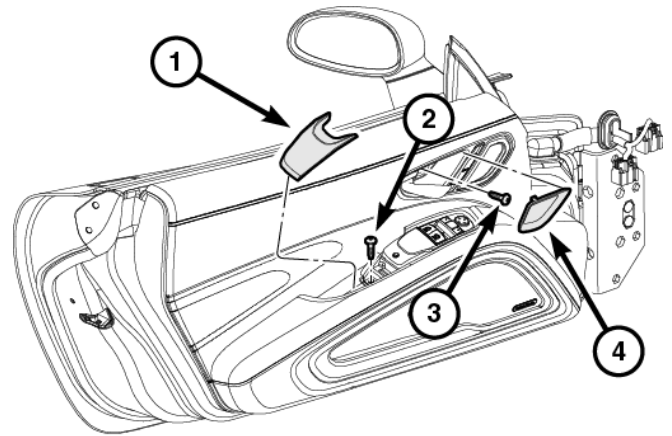

231074330

- Using a trim stick or equivalent, disengage the retaining clips (2) securing the door trim panel (1) to the door.

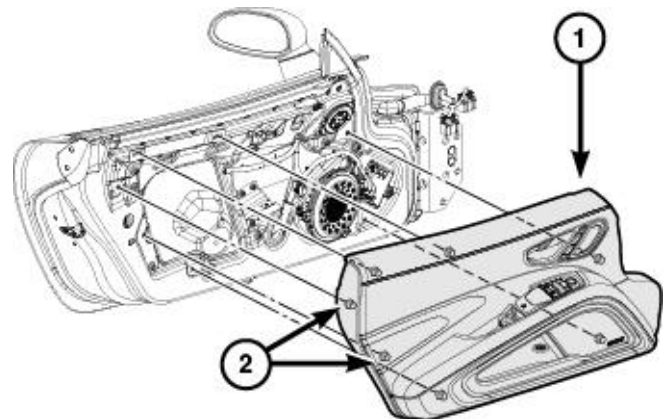

231074329

- Position door trim panel slightly away from the door.
- Disconnect the wire harness connectors (2,3,4 and 5).
- Using a small flat bladed tool or equivalent, separate the cable housing grommet and disconnect the inside handle release cable (1).

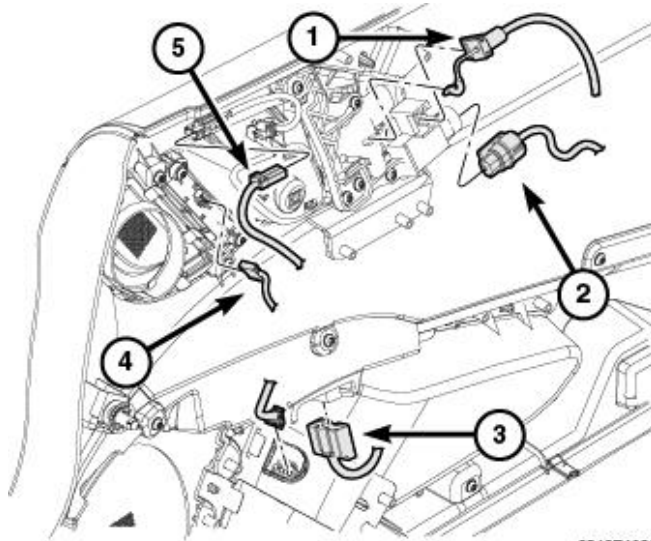

231074328

- o Remove the 2 or 3 trim pieces required to access the screws holding the door on.



Gen 5 Door Panel Bolts on a 2017



Backside of trim pieces removed to gain access to screws

- With the screws removed pull outward on the door trim, do not pull trim too far away from the door



Backside of door trim showing multiple electrical and mechanical connectors and tethers

- Disconnect the multiple electrical and mechanical connectors attaching the door trim to the door
- Peel back vapor barrier from the two sections shown



Peel back vapor barrier shown to allow access to window/regulator bolts

- Position window to allow access to the 2x regulator bolts and remove them.
- Find a window position that allows easiest access to the window bosses through the larger hole in the door. Raising the window and allowing it to angle downward can provide clearance. Multiple positions may be needed to access each boss. *Note: when raising or lowering the window use your hand to help guide it up or down as it is no longer attached to the rear side of the regulator.*
- Remove the OEM parts by twisting apart, keeping in mind the thread is left handed.



Window aligned to allow access to regulator bolts

- Prepare the DSE bosses (see Installation Guide above). Install the plastic/stainless piece in the window and keep your hand on it to hold together and in place.
- Thread in the aluminum part (male threads prepped with Loctite). Hold gasket to keep it centered while tightening.
- Once both bosses have been installed return window to the location required to access both regulator bolts through the door.



DSE Bosses Installed in Window Prior to Attachment to the Regulator

- Thread in the bolts that attach the window to the regulator. Keep your hand on the back side to ensure the boss isn't twisting with the bolt and remains tightened. Fully tighten regulator bolts.
- Test window operation (up/down) to ensure all is working properly.
- Reinstall the vapor barrier, electrical connectors and mechanical tethers, door trim, trim screws, and access panels.

- **EXCERPT FROM THE GEN V SERVICE MANUAL-**

1. Position door trim panel slightly away from the door.
2. Connect the electrical connectors (2,3,4 and 5).
3. Connect the inside handle assembly release cable (1).

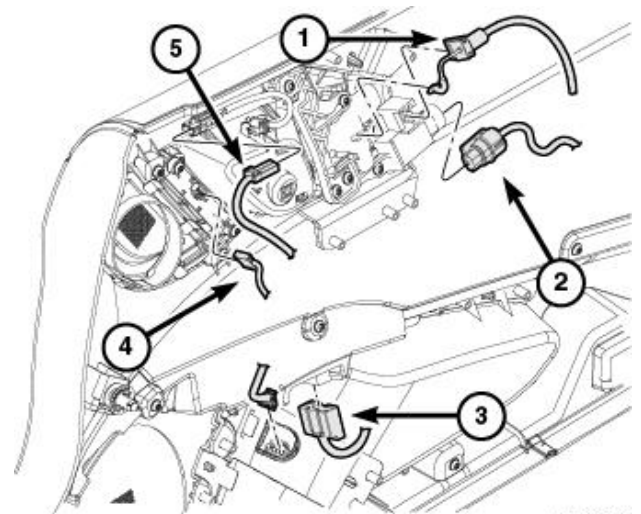

231074328

NOTE: The upper center anchor slot (2) of the door trim panel (1) is not utilized.

4. Connect the tether clip to the appropriate anchor slot (3) of the door trim panel (1).

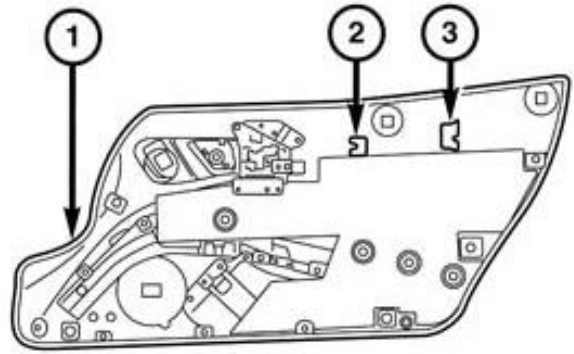

5. Align the door trim panel retaining clips (2 and 3) to the appropriate mating attachment holes but do not engage any of the retaining clips at this time.
6. Support the bottom of the door trim panel (1) while the retaining clips (2 and 3) remain loosely targeted with the mating holes.
7. Verify that the retaining clips (3) are targeted to the mating belt line attachment brackets as well as the remaining clips (2) to the appropriate holes.
8. Once alignment is achieved, push the door trim panel in the outboard direction, listen for an audible snapping noise to be certain the retaining clips are fully seated.

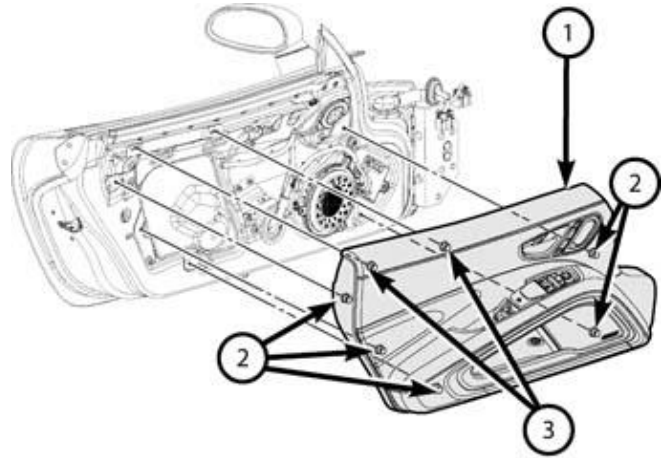

2310007836

9. With the use of hand pressure, apply pressure at or near the two front retaining clips (1), listen for an audible snapping noise to be certain the retaining clips are fully seated.
10. With the use of hand pressure, apply pressure at or near the two rear retaining clips (2), listen for an audible snapping noise to be certain the retaining clips are fully seated.
11. With the use of hand pressure, apply pressure at or near the rear lower retaining clip (3), listen for an audible snapping noise to be certain the retaining clip is fully seated.

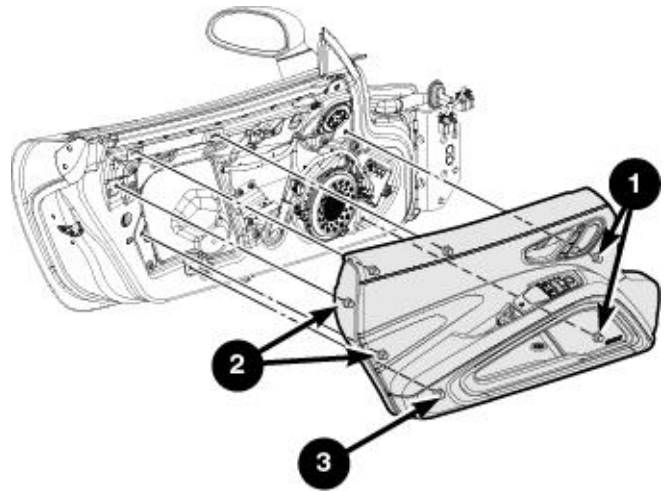

2310007836

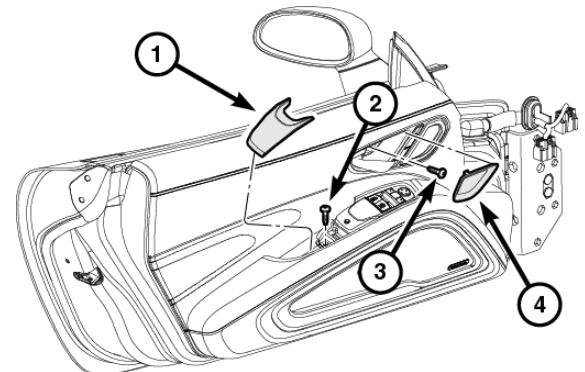

12. Install the screw into pull handle pocket (2) and tighten securely.
13. Install the pull handle bezel (1).
14. Install the screw (3) into the interior release handle pocket and tighten securely.
15. Install interior release handle bezel (4).
16. Connect the negative battery cable.



231074330

THE FOLLOWING IS FOR REFERENCE ONLY AND SHOULD NOT BE NEEDED FOR WINDOW BOSS REPLACEMENT

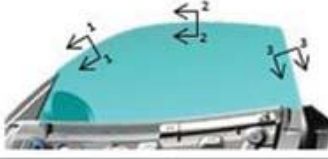
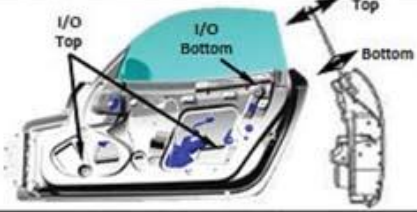
TOP OF GLASS – INBOARD/OUTBOARD ADJUSTMENTS

MEASUREMENT LOCATIONS AND THEIR VALUES			
	SECTION 1-1	SECTION 2-2	SECTION 3-3
			
Sequence 1 - IN/OUT ADJUSTMENT	Measurement U	Measurement W	Measurement Y
	11mm +/- 2mm	11mm +/- 2mm	0mm +/- 2mm
Sequence 2 - FORE/AFT & UP/DOWN ADJUSTMENT	Measurement V	Measurement X	Measurement Z
	5mm +/- 2mm	6mm +/- 2mm	8mm +/- 2mm

1. Remove move door trim panel,

NOTE: Glass position measurements are to be taken with all weatherstrips in place.

2. Using a 10 mm socket, loosen the jack screw nuts (1).
3. Using a 3 mm allen wrench, rotate the jack screw to achieve the proper gap between the door glass and the weatherstrip retainer. Tighten the jack screw nuts (1) to 7 N-m (62 in. lbs.) prior to measuring the gaps.
4. Cycle the glass fully down and up, open and close the door. Verify that the edge of the door glass is engaging into the weatherstrip.
5. Install door trim panel

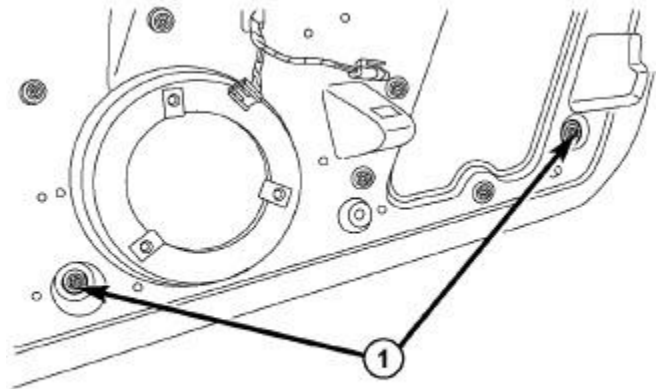

81273649

UP/DOWN AND FORE/AFT ADJUSTMENTS

1. Remove door trim panel,
2. Loosen the up stop and fore/aft fasteners.

NOTE: Glass position measurements are to be taken with all weatherstrips in place.

3. Close door and raise door glass.
4. With the use of a sharp grease pencil or equivalent, mark the exposed edge of the glass (1) in its up position to determine if it is properly set in the up/down and fore/aft position

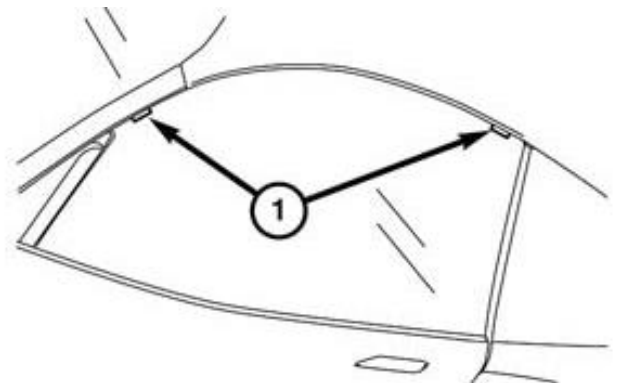

5. Adjust the glass to achieve the proper glass to weatherstrip retainer gap.

6. Tighten the glass fasteners (1) to 4 N·m (35 in. lbs.).
7. Tighten the up stop fastener (2) and any remaining adjustment fasteners to 7 N·m (62 in. lbs.).

8. Cycle the glass fully down and up, open and close the door. Verify that the edge of the door glass is engaging into the weatherstrip.

NOTE: Verify that the forward edge of the glass is flush with the mirror flag edge. Adjust the mirror flag as necessary to achieve a flush condition.

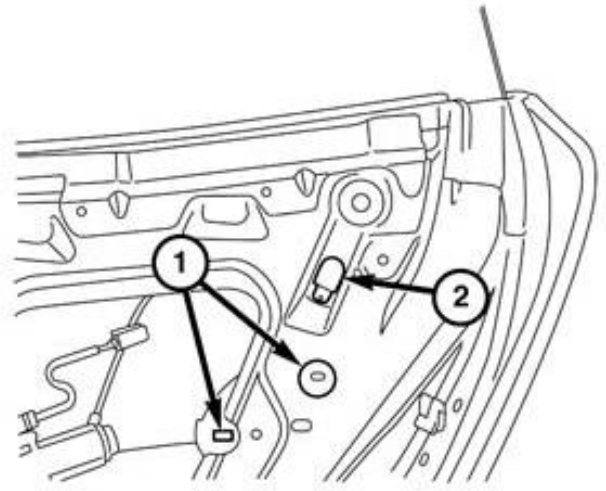

9. Install door trim panel

DOOR GLASS ALIGNMENT VERIFICATION

NOTE: Door Glass Alignment Verification procedure must be done whenever the door glass is adjusted and after all adjustments are made.

1. Close door and cycle door glass between full up and full down positions.
2. Verify that door glass operates smoothly and maintains correct alignment to roof and A-pillar.
3. Verify that door glass does not contact roof or seal retainer lip during door closing with glass full up position.
4. If any of the above conditions are found, adjust the door glass as necessary to cure the condition.

DOOR MODULE LEARN PROCEDURES

NOTE: This procedure must be performed anytime the power window system has been serviced in either front door or when there is a possible concern with a door module calibration. The battery must be fully charged or the vehicle running before proceeding with the learn procedure. All doors must be completely closed before proceeding. It is suggested to sit inside the vehicle in the drivers seat and close the door.

Express-up / Express-down possible concerns.

Glass will not lower all the way down flush to the belt-line.

Glass will not raise fully; wind noise / water leak.

Glass will not raise automatically (Express-up) after lifting the switch to the second detent and releasing.

To relearn the door module memory after module replacement, perform the following procedure:

1. Check and repair any door module Diagnostic Trouble Code (DTC)(s) unrelated to missing calibration before proceeding.
2. Using the window switch, lower the door glass to the full-down position by pushing down (depress) the window switch to its second detent and hold the switch until the door glass is fully open. Continue to hold the window switch down for two seconds after the door glass is fully open.
3. Raise the door glass to the full-up position by pulling up on the window switch and hold the switch until the door glass is fully closed. Continue to hold the window switch up for two seconds after the door glass is full closed.

4. Code should now be stored. Clear code and test window operations.

To relearn the door module memory after window/regulator replacement, perform the following procedure:

1. Using the scan tool, go to the network topology screen.
2. Click on the Diagnostic Procedures tab at the lower portion of the screen.
3. Run ECU Reset for DDM/PDM.
4. DDM/PDM calibration missing DTC will now set.
5. Using the window switch, lower the door glass to the full-down position by pushing down (depress) the window switch to its second detent and hold the switch until the door glass is fully open. Continue to hold the window switch down for two seconds after the door glass is fully open.
6. Raise the door glass to the full-up position by pulling up on the window switch and hold the switch until the door glass is fully closed. Continue to hold the window switch up for two seconds after the door glass is full closed.

Thank you for your purchase!

Your business is appreciated and customer satisfaction is our top priority! Don't hesitate to contact us via email with any questions or feedback. Word of mouth is the best form of advertising so if you are satisfied please spread the word!

Disclaimer of Liability:

Doug Shelby Engineering assumes no liability expressed or implied for the improper installation or use of this product or its components. Doug Shelby Engineering is NOT responsible for any damage, consequential or otherwise for equipment failure after installation.

Vehicle Modification:

Modification of your vehicle with the parts identified above may alter its stock performance; the buyer hereby expressly assumes all risks associated with any such modification.

Disclaimer of Warranty:

Seller disclaims any warranty express or implied with respect to the parts sold hereby whether as to merchantability, fitness for particular purpose, or any other matter.