

1971 AVION TRAVEL COACH

See Serial 32747

Avion 27-441 2nd mark

7-41 11/11/44 11/11/44

*7-11 Avion 11/11/44
11/11/44*

Operation and Service Manual

Keep this book with your Avion at all times

AVION COACH CORPORATION

1300 E. Empire Avenue, Benton Harbor, Michigan 49022

WARNING

POTABLE WATER ONLY

SANITIZE, FLUSH AND

DRAIN BEFORE USING.

SEE INSTRUCTION MANUAL

This label appears on your coach near the manual fill spout and at the hose storage compartment. Your water system may be sanitized by filling the tank with potable water, adding two (2) cups of Clorox (one tablespoon per gallon), allowing to stand for 30 minutes and then draining the tank by pumping the contents through the water distribution system. To flush, repeat with fresh water. Refer to water system instructions on page 10, item 5 in your owner's manual.

AVION TRAVEL COACH

OPERATION AND SERVICE MANUAL

TABLE OF CONTENTS

Section	Page
I Hook-up Procedure	3
II Parking & Set-up Procedure	4
III Protection from Freezing Weather	5
IV Operation – Care – Maintenance	7
V Trouble Shooting	19
VI Warranty Information	23

Water Pump Switch.
Top of Hitch Ball 20" to Top
Were Batteries removed in winter
TV antenna
110V lead in connection

SECTION I

GENERAL PROCEDURE FOR "HOOKING-UP" BEFORE A TRIP

The following steps are suggested as a check list before starting on your trip with your Avion Coach.

1. See that all clothing, dishes, golf clubs, fishing gear, etc., are properly stored. Heavy gear should be located near the floor and as near to the center of the coach as possible. It is wise to use square plastic containers in your refrigerator. **DO NOT** leave ice cubes in the freezer compartment unless the refrigerator is operating while traveling. Pack rolled towels in front of the containers in the refrigerator so they will not move about or spill over. Insert the safety pin in the refrigerator door to prevent it from opening while traveling. Unless you plan extended stays far off the beaten path, there is no need to store up on food.

2. Be sure all drawers, cupboards and closet doors are securely latched. The single-piece bathroom door may be latched closed for traveling. If your trailer is equipped with a bi-fold door, it should be hooked open.

3. Radios, TV sets, books, folding chairs, etc., should not be placed on top of beds while traveling. The vibration of the mattress and springs has a tendency to move everything forward and, if the brakes are applied quickly, they may be thrown to the floor. Loose items should be placed on the floor near the center of the trailer.

4. If your utilities are hooked up, disconnect the 120 volt Power Cord at the receptacle and store in the cord storage compartment. Close the range top pilot valve, if pilot has been used, close the oven shut-off valve. See instructions for Range and Oven in Section IV.

5. Flush the holding tank, refill with 2" of water and add a commercial holding tank chemical, if desired. Disconnect the sewer and water hoses, drain and store. The sewer hose may be kept in the rear bumper. **Be sure to lock the holding tank valve into closed position, and turn off the water pump switch.**

6. Close all windows and ventilators, lower the TV antenna and lock the entrance door. When traveling on extremely dusty roads it is advisable to leave the front roof vent slightly open into the wind. This has a ten-

dency to create an air pressure inside the coach and prevents dust from filtering in. Be sure the front awning is closed and latched on both sides.

7. Remove the stabilizing jacks or blocks from under the coach and fold the step into the "stored" position.

8. A 2 $\frac{5}{16}$ " hitch ball should be mounted on your car, so that the top of the ball is 20" from the ground. At this height, and with an equalizing hitch properly adjusted, your Avion coach will ride level. Although the Avion will tow properly even if the coach is not perfectly level, we recommend that trailer and car ride as level as possible.

To hook the coach to the towing vehicle, raise the front of the coach with the post jack and have your partner back the car into place.

After the ball has been positioned under the hitch socket, check to be sure that the locking lever has been raised and pulled to the rear, then lower the front end of the coach onto the ball. Rock the car back and forth enough to be sure that the socket and ball are fully engaged, and put the ball lock in place. The lock should be secured by placing a safety pin or small lock through the hole just to the rear of the latch.

Jack up the front of the coach again (the car will come up with it) and put on the balance of the hitch, adjusting for level in both units. It is advisable to use an equalizer type hitch. Make all adjustments according to the manufacturer's instructions.

Lower the coach onto the hitch, remove the dolly wheel, or any blocks that may have been used under the post, and crank the jack post to the highest possible position. Hook up the electric connections from the car to the coach, connect the safety chains and anchor the break-away switch cable to the auto.

9. Check the brakes and lights.

10. Re-check all previous steps and be sure to leave your parking area clean. It is a good practice to pull your coach a short distance from the parking spot and inspect the area before departing.

SECTION II

PARKING AND SET-UP PROCEDURE

1. When positioning the coach, try to select a spot as level as possible. Do not use jacks to level the coach. It should be leveled by driving up on a board, or by using a shovel to level the area under the wheels before positioning. Jacks can then be used to stabilize the coach.

CAUTION: When locating jacks or blocks, **DO NOT** place them under the aluminum underbelly or skin. Stabilizing jacks for Avion coaches should be placed under the frame at the front and rear of the coach. Extend the jacks only enough to support the frame.

2. Make water, sewage, and electric hook-ups if your stay will be long enough to require them.

3. Light pilot lights, raise front awning and lock in place.

SECTION III

PROTECTION FROM FREEZING WEATHER

1. Level the coach and disconnect water supply hose. The water lines in your coach have been installed with a slope to permit gravity draining. Inspect these lines to be sure they have not been bent out of position. Water lines from bath lavatory and galley sink should slope toward water heater, draining through the heater tank drain. The water lines from the galley sink forward should slope to the water tank drain valve.

2. Drain the water storage tank by opening the drain valve which is located at left end of the tank. The storage tank may also be drained by opening one or more of the faucets and pumping the water into the sinks, where it will drain through the sewer hose.

3. Shut off water pump at switch, open all faucet valves, and drain water heater tank. The valve for this tank can be reached by removing the panel on the outside of the water heater. Be sure that the water heater has been turned off before draining.

4. Remove water from the stool by holding both foot pedals down and allowing the system to drain. Be sure the water supply has been turned off and that the cold water faucet in the bathroom sink is open. This will vent the water line to the stool and allow it to drain.

Remove the flare nut which connects the water line to the back of the stool. Break the connection, hold the pedal down and allow the water to drain. Be sure to replace and tighten the flare nut before using the water system.

Lay the water saver spray gun on the floor and put a rubber band around the thumb button to hold the valve open and allow it to drain. The spray head may also be removed from the hose to prevent damage from freezing.

Should water accidentally be left in the stool, damage may be prevented by allowing the unit to thaw out at room temperature before using. **DO NOT ATTEMPT TO FLUSH A FROZEN STOOL.**

5. Pull up on shower spray valve to open. Open shower head and allow all water to drain from the hose.

6. Open the holding tank valve and drain tank completely. (Drain should be connected to sewer for this operation.)

7. Raise the front end of the coach as high as it will go by cranking the jack all the way up and allow water to drain. Then crank jack to lowest position and allow water to drain. Return to level position.

8. Use suction pump to remove water from traps, or pour about one cup of any Ethylene Glycol type anti-freeze in each of the three traps — one in the kitchen sink, one in the bathroom sink, and one in the bathtub. Use caution to avoid spilling the solution on plastic surfaces where discoloration may occur. **DO NOT** use an alcohol base anti-freeze.

9. If your trailer is equipped with a purifier, remove the cartridge, allow to dry and store until ready to use again.

10. Drain the water pump as illustrated on the next page. Turn the pump off. Place a small pan under the end of the water line at the connection to the pump discharge hose — Location “A”. Loosen the brass flare nut and disconnect the hose fitting from the copper line. Allow any remaining water to drain from the line into the pan. Keep the sink faucet open to vent this line while draining. Lay the pump discharge hose flat on the floor and start the pump. Use a rag or sponge to wipe up the small amount of water that will be discharged from the opening.

Turn the pump switch off and do not connect the hose to the water line until warm weather, or until the coach is prepared for use.

Open the cold water faucet at the kitchen sink. Open the water fill bi-pass valve which is located under the kitchen sink — Location “B”. Open the drain valve at the left end of the water tank and allow the water in bi-pass line to drain — Location “C”. Remove the hose connection from the left end of the plastic water filter — Location “D” — to provide a vent and permit water trapped in the filter to drain out through the tank drain.

11. Insert a stiff wire or slender rod into the water inlet fitting which is located in the hose storage compartment. Push upward to release the spring tension in the check valve and allow water to drain from it. Be sure faucets are open to vent the line.

12. If it is practical, remove the batteries and store in a warm place during freezing weather. If the batteries are kept on the coach, be sure that they have a full charge to prevent freezing.

13. **CAUTION** — Do not travel with the anti-freeze solution in the tub or lavatory drains unless the drain plugs are securely inserted to prevent the solution from splattering on the plastic.

PROTECTION FROM FREEZING WEATHER

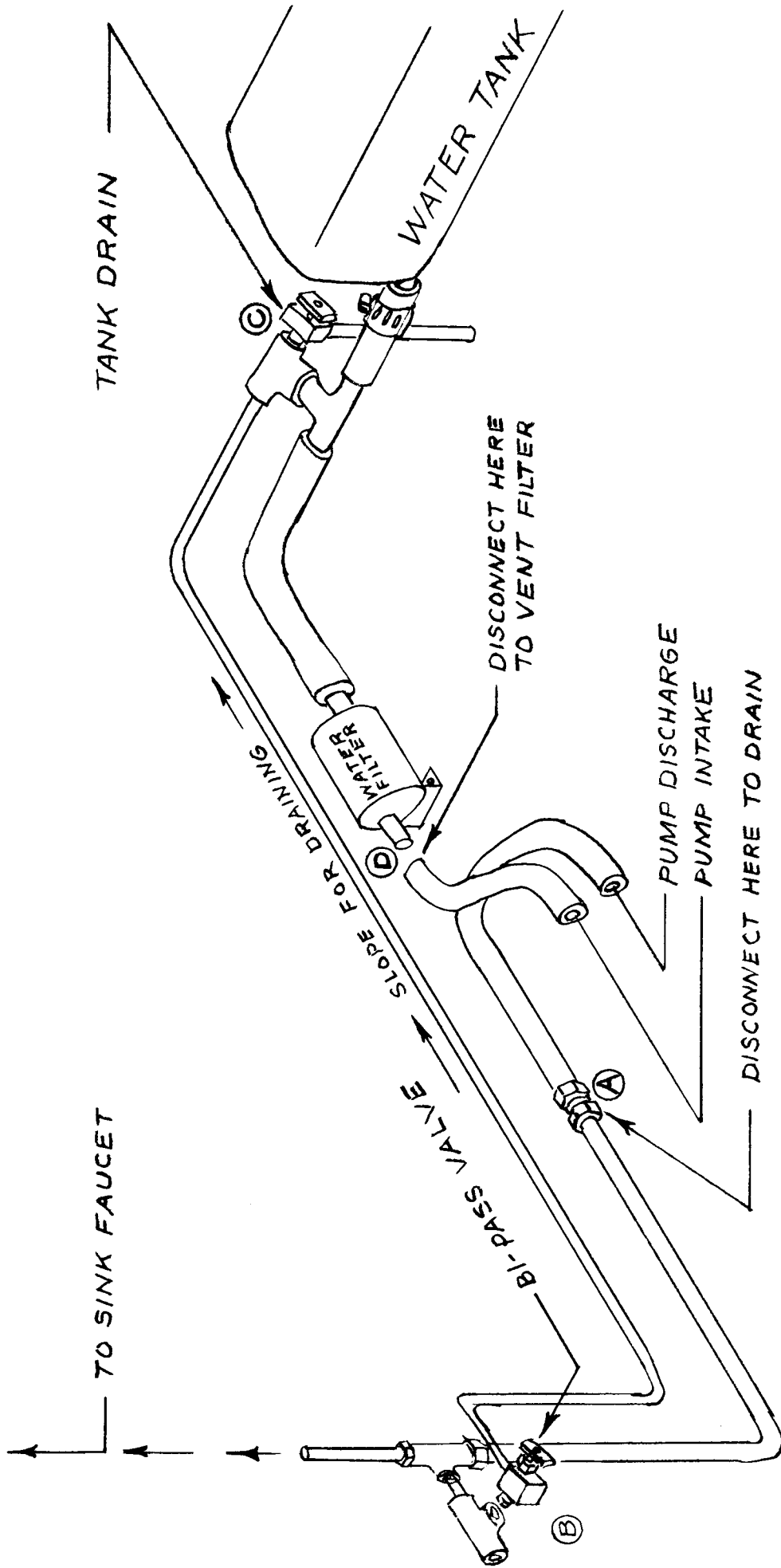

SECTION IV

OPERATION – CARE – MAINTENANCE

Item	Description	Page
1.	Care and Cleaning	8
2.	Window Screens and Storms	9
3.	Door Lock	9
4.	Electrical Systems	9, 10
5.	Water System	10, 11
6.	Gas System	11
7.	Water Heater	12, 13
8.	Gas Furnace	13
9.	Water Closet	13, 14
10.	Waste Holding Tank	14
11.	Gas – Electric Refrigerator	14
12.	Range and Oven	14, 15
13.	Range Hood	15
14.	Running Gear	15, 16
15.	Converter	16
16.	Break-Away Switch	17
17.	Instrument Signal Center	17
18.	Air Conditioner	17
19.	TV Antenna	17, 18
20.	Water Purifier	18
21.	Stereo Tape Player	18

CARE and CLEANING

WINDOWS are Plexiglas acrylic plastic. They should be dusted and cleaned with a damp cloth or chamois, wiping the surface gently horizontally. Wash with a mild soap or detergent and water. Use as much water as possible, applying with a clean soft cloth, sponge or chamois. The best method of drying is with a clean damp chamois.

You can protect them with a good grade of commercial wax. Apply and bring it to a high polish by rubbing with a soft dry cloth.

To remove or reduce minor scratches, hand polish with a small cloth or pad dampened in water. Deep scratches may be removed by sanding with a very fine sandpaper, keeping wet while sanding. Use a 320 or 400 grade sandpaper. Buff with a fine abrasive after sanding and then polish to a high gloss with wax.

CABINETS and WOODWORK deserve the same care as the furniture in your home. A furniture wax or polish will aid in maintaining the fine factory finish. Upper cabinet doors are equipped with a single-arm friction brace. Tighten the adjusting screw to increase friction if the door does not stay in open position.

INTERIOR WALLS are covered with vinyl. They may be cleaned by washing with a mild soap or detergent and water. DO NOT use an abrasive cleaner or a solvent as it may damage the vinyl or dull the finish. Avoid exposure to concentrations of propane or natural gas. The bathtub should have the same care as the interior walls.

DRAPERIES, optional bedspreads and slumber bags are of high quality synthetics and should be dry cleaned.

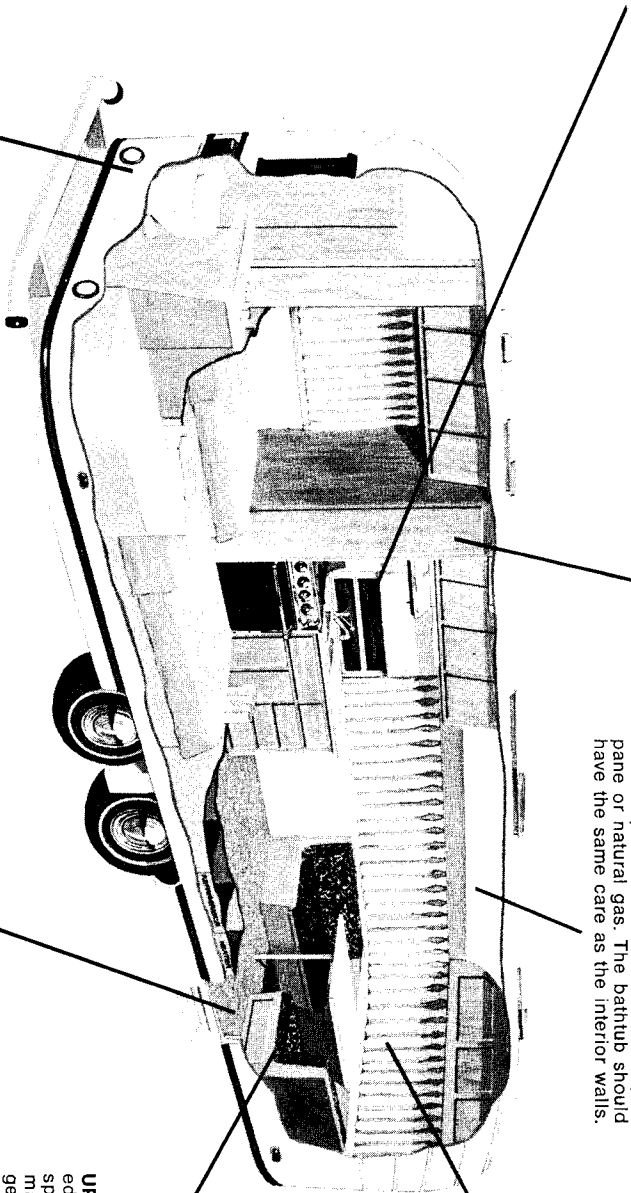

UPHOLSTERY is soil resistant treated to minimize spotting. (Sponge up spills immediately.) Soiled areas may be cleaned with mild detergent and water.

CARPETING (optional and factory installed) is 100% polyester. It may be cleaned with any good grade of foam carpet cleaner. Follow the instructions on the container. The Johnson Wax product "Glory" has been found to work well.

EXTERIOR SKIN of anodized aluminum should be washed and cleaned in the same manner that you care for your automobile. Wash with a mild soap or detergent. Road tars may be removed with kerosene, turpentine or naphtha. Follow the cleaning with a soap and water rinse and then dry with soft, absorbent material.

CAUTION: When using these liquids, do not allow them to get on the window panes. Do not use cleaners containing caustic or ammonia.

A polish may be used on the exterior surface to provide additional protection. A cleaner-wax-polish type material should prove satisfactory, if the manufacturer's instructions are followed. Be sure to do the polishing in the shade, rubbing the same direction as the grain in the metal.

A more permanent protection may be obtained by applying a coating of clear wax after the polishing is completed.

Exterior seams should be examined periodically for holes or cracks which may result from shrinkage of the sealer after prolonged exposure to the elements. The sealer for all exterior seams of your Avion carries the brand name of "Ten-X". It is manufactured by Electro-Cote Company, Minneapolis, Minn., and can be purchased from most trailer dealers and automotive supply stores.

2. WINDOW SCREENS and STORMS

Removal of the window screen is accomplished by pushing upward on the screen frame until it clears the bottom channel. It can then be pulled out from the bottom and removed.

Optional storm sash may be installed without removing the screens. Small clips around the inner frame are used to secure the storm sash in place.

3. DOOR LOCK

The entrance door is equipped with a "Dead-bolt" lock. Turn the key to the right (clockwise) to lock the door, and to the left (counter-clockwise) to unlock it.

The door can only be locked when the bolt is fully engaged. When locked, the bolt cannot withdraw or vibrate back and allow the door to come open. Always lock the door before towing your Avion. Check the lock by attempting to open the door with the outside handle.

The door can be locked from the inside by depressing the button under the handle. Turning the inside handle will automatically unlock the door. Do not attempt to lock the door while open and then close it.

4. ELECTRICAL SYSTEMS

Each Avion coach is provided with three separate electrical circuits: (A) 12-volt exterior light and brakes; (B) 12-volt interior lighting system; (C) 120-volt interior system.

(A) **Exterior Lights** – The cluster lights and clearance lights are I.C.C. regulation approved. Check these lights periodically to be sure that the bulbs are burning. Replacement bulbs are G.E. type 1895 or equivalent.

The tail lights and turn lights are in single lamps at the rear of the coach. They use double filament bulbs, G.E. type 1157 or equivalent.

Power for the lights and brakes is supplied from the automobile battery, through the 7-wire connector. The coach wires appear in a heavy cable at the trailer hitch.

WIRING CODE FOR AVION COACHES

#1 – White	connects to:	Brake – Ground
#2 – Blue		Brake – Hot
#3 – Green		Clearance Lights
#4 – Black		Battery Charging by Tow Vehicle
#5 – Red		Left Turn Light
#6 – Yellow (Brown)		Right Turn Light
#7 – Black-Center Post		Backup Lights

A separate wire is provided to connect the automobile alternator to the coach battery. This wire is taped to the 6-wire cable. It is connected to the positive battery terminal at the factory for cars with standard "negative ground" system.

Brakes – Your coach is equipped with 12-volt electric brakes. The 22 ft., 25 ft., and 28 ft. tandem axle models are equipped with 10" brakes. The 31 ft. tandem axle model is equipped with 12" brakes.

These brakes have been adjusted at the factory for smooth, positive braking. If brake adjustment becomes necessary it should be done by your dealer's service department or by a competent automotive mechanic. The method of adjustment is the same as most automotive brakes.

INTERIOR LIGHTING

(B) **Interior Lights** – The lights, fans and water pump are operated on 12-volts direct current. This energy may be provided by the standard equipment batteries which are located at the front of the trailer, or by the converter.

Two 12-volt batteries are provided to give a greater amount of reserve energy for self-contained operation. These batteries are connected in parallel. Should one battery fail to function, the other battery will continue to provide power, to the limit of its capacity. If, for any reason, one battery is removed from the circuit, be sure that it is correctly re-connected, as illustrated on page 10.

The batteries should be checked periodically to be sure that they are at the proper charge level. Use a hydrometer to test the individual battery cells. A fully charged battery will have a specific gravity reading of 1.260 to 1.280 at 80 degrees fahrenheit.

When checking a battery, be sure that the level of the electrolyte (water) is adequate to cover the tops of the separators. Permanent damage may occur from charging and/or from traveling with plates not fully covered. When the electrolyte is low, add filtered or distilled water to obtain the proper level. Keep the battery terminals clean by wiping with a cloth wetted in baking soda or ammonia and water. Inspect wires and battery terminals for corrosion or poor connections.

To prevent damage to the batteries, never allow them to become fully discharged. The specific gravity should not be allowed to drop below 1.150. Be sure that the 120-volt power cord is fully plugged into the outlet whenever AC service is available. Use of 120-volt service will not only save battery energy, but it will also provide automatic charging to keep your batteries in top condition.

continued on next page

Electrical Systems (cont'd)

The batteries are warranted for one year. A list of independent Battery Manufacturers is provided in the Warranty Kit supplied with your coach. Consult this list and contact the nearest manufacturer to obtain the name of a retailer that can provide service and make adjustments.

22 foot and 25 foot coaches are equipped with two 65 ampere-hour batteries, group no. 24 HRV. The 28 foot and 31 foot coaches are equipped with two 80 ampere-hour batteries, group no. 24 TRV.

The converter, or charger, provides 12-volt direct current whenever the power cord is plugged into a standard 110-120-volt 60 cycle AC source. It also provides the energy to charge the batteries. As a battery charger, the unit senses the state of the battery charge and will automatically charge and shut off as required. The converter is protected by a built-in circuit breaker. If a short, or overload is occurring, a 7 to 10 second clicking sound will be heard as the automatic reset breaker clicks off and on. The converter may be disconnected from the 120-volt source by removing the cord from the wall outlet adjacent to the unit. The converter is located on the trailer floor at the right front corner.

Two fuse blocks are provided to protect the 12 volt system. The battery box fuse block has two pairs of fuses. One pair protects the car charging line. The second pair protects the line to the converter. Both fuses in each pair must be in place at all times so that the load is divided between them. Extra clips are provided for two spare fuses.

The second fuse block is located inside, underneath the front shelf. Circuits and fuse sizes are shown below.

12-VOLT INTERIOR LIGHTING SYSTEM

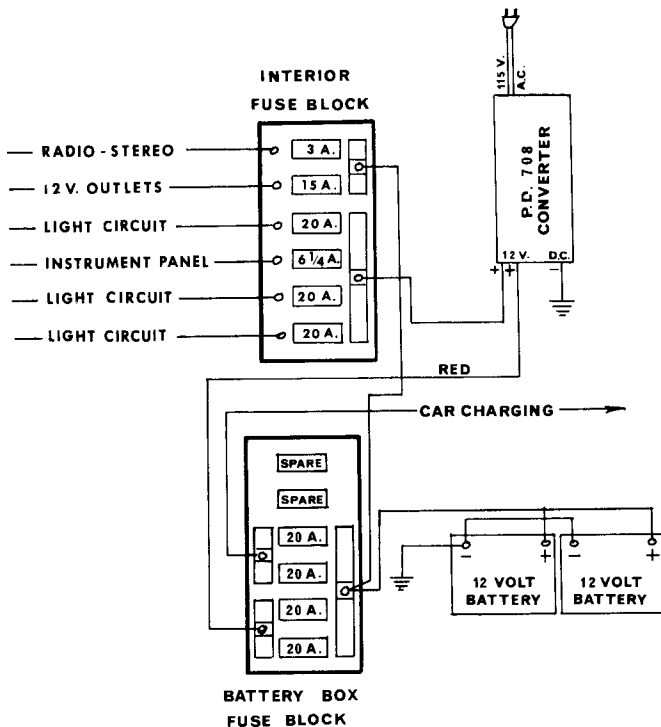

Two 12-volt utility (cigarette lighter) outlets are provided in each coach. One is located in the bathroom and the other is adjacent to the TV antenna jack in the bedroom. Use #1141 12-volt bulbs for ceiling and cornice light replacement. Clear bulbs are available at auto service stations. Frosted bulbs may be obtained from Avion Dealers, or Avion Service Corporation.

Replacement bulbs for the two 12 v. recessed lights under the front end cabinet are G.E. part no. 25 R 14 SC/SP. These are available from Avion Service Corporation.

(C) **Interior 120-volt** — The numerous wall outlets in your coach are located to provide convenient electricity for the various 110-120 volt appliances such as an iron, toaster, percolator, etc. These outlets can be used whenever the 25 ft. Power Cord is plugged into a 120-volt AC source. The Power Cord is stored under the left rear side of the coach. When connecting it to an outlet, arrange the cord so that the weight of it does not cause a poor connection. The cord storage opening has a slot in it so that the storage door may be kept closed while the cord is in use. A weatherproof outlet is located on the exterior of your coach for convenience in using tools and appliances outdoors.

The 120-volt system is protected by circuit breakers. These are located in a box at the back of the bathroom closet. The main breaker is 30 amps. Turning it off will disconnect all 120-volt wiring in the trailer. Separate breakers are provided for: (1) Appliance Circuit, (2) Air Conditioning Circuit, (3) General Purpose Circuit and (4) Water Heater Circuit.

5. WATER SYSTEM

Your Avion is equipped to provide water service from a city water system or from the self-contained water tank. Connection to a city water supply is made through a water hose connected from the city supply to the water fitting on the trailer. This fitting is located in the storage door on the left side of the coach. A pressure reducing valve protects against excessive city pressures.

A molded plastic water tank is located at the front of the trailer, behind the sofa or dinette. The fill spout appears on the outside of the coach at the front. The tank may be filled by removing the filler cap and using a hose or bucket to add fresh water. A bi-pass line is also provided to permit filling the tank while connected to a city water supply. To fill the tank, remove the front spout cap to prevent pressure build-up, and then open the bi-pass valve which is located under the counter top. See illustration on page 6. The tank will overflow at the front fill spout when full. When this happens, close the valve and replace the spout cover. This valve should be kept fully closed except during filling. **DO NOT LEAVE THE TRAILER UNATTENDED WHILE FILLING THE TANK.** Turn off the water pump switch during BI-PASS FILLING.

continued on next page

Water System (cont'd)

The water tank may be drained by opening any faucet with the pump turned on or by opening the drain valve at the left end of the tank. This valve is accessible by removing the cushion and lifting the storage lid in the left seat on dinette models, or by removing the cushion and pulling out the sofa.

The coach is equipped with a Peters & Russell water pump to supply water pressure whenever a faucet is turned on. A switch is provided to turn the pump off while the coach is unattended, or when connected to a city water supply. **DO NOT TRAVEL WITH THE WATER PUMP SWITCH IN THE "ON" POSITION.** The surge of water, which can occur during starting and stopping, may cause the pump to turn on. Since no water can run and allow the pump to cycle, it will continue to run and not shut off.

The pump is mounted on the floor at the left front corner of the coach. It has a built-in check valve to prevent water from backing up into the storage tank when the system is connected to a city water source.

The model 6950-J pump is warranted by the manufacturer for a period of **one year**. Warranty service and parts may be obtained from: **Peters and Russell, Incorporated, 529 West Liberty Street, Springfield, Ohio 45501.** Their telephone number is AC 513 323-3777.

A filter is located in the water line between the tank and the pump. Inspect this filter periodically to be sure that an accumulation of foreign matter does not impair the water flow. The filter may be cleaned by removing it and rinsing or back-flushing, or by disassembling the two halves and removing the screen to clean it.

The bathroom lavatory fixture has a divert button to direct the water flow to the shower head. The built-in push button control in the shower head is designed for volume control (water saver) and is not intended as a shut-off valve. A slight trickle though in the closed position is normal. After using the shower be sure to shut off the water at the lavatory faucet.

The kitchen sink is equipped with a Model 7525 Moen faucet, with a 12-month warranty. Complete and mail the warranty card in the Warranty Envelope provided with your trailer. For warranty service or parts, consult the classified section of the telephone book for the name of a plumbing contractor, or write the manufacturer: **STANDARD SCREW COMPANY, 377 Woodland Avenue, Elyria, Ohio 44035.**

6. GAS SYSTEM

The coach gas system consists of two gas tanks or bottles, a regulator, gas distribution piping, and the various appliances which operate on gas.

This system is designed for use of liquefied petroleum (LP) gas only. Do not connect natural gas to this system. Before turning on gas, make certain all gas connections have been made tight, all appliance valves are turned off, and any unconnected outlets are capped.

After turning on gas, test piping and appliances for leakage with soapy water, and light all pilots.

The two gas bottles are located at the front of the coach. Each is equipped with a valve to control the flow of gas. A regulator is used at the tanks to reduce and control the pressure from the tanks to the appliances. The regulator is preset at the factory to maintain a pressure of 11" water column, or approximately 6½ ounces per square inch. All appliances are adjusted to operate at this pressure.

When filling bottles, do not leave end of gas line (pig tail) open, even for a few minutes. Bugs are attracted, die inside tubing and plug the line. Tape tube end shut while filling bottles.

Automatic Regulators

Automatic regulator provides uninterrupted service to your gas system. Both bottle valves must be open to permit automatic change-over. An indicator on the regulator will show red when the regulator automatically begins to draw from the reserve cylinder. The arrow on the flip-over lever will point to the empty service cylinder. Flipping the lever to the opposite position will change the Reserve cylinder to the Service cylinder. It will also cause the red indicator to disappear. Close the valve of the empty cylinder before removing it for refill. After refill and replacement, it will become the Reserve cylinder. The next time the red indicator appears the process should be repeated. NOTE: If the system is under heavy load, particularly in cold weather, the Service cylinder pressure may drop enough to indicate Reserve, even though there is fuel in the Service cylinder. Do not consider the cylinder exhausted until it shows red (Reserve) under a light load.

Testing for Gas Leaks

All gas line fittings, except those at the individual appliances, are located outside the coach. Several connections will be found under the coach, where the main gas line branches off to supply the individual appliances. These gas lines and fittings should be inspected and tested periodically for possible damage and leaks. Brush or spray a soap suds solution over all fittings and any damaged areas in the line. The bubbles will grow in size to indicate the presence of a leak.

If the odor of gas is detected inside the coach, extinguish all flames and test for leaks. If the leak cannot be detected, turn off the valves on both gas bottles and see your dealer's service department, or a competent gas appliance service man. **DO NOT CONTINUE TO USE YOUR GAS SYSTEM UNTIL THE LEAK IS LOCATED AND ELIMINATED.**

The gas appliances in your coach are designed and adjusted to use L.P. gas. Propane gas is the most common type. Butane may be used but will not vaporize, or turn to gas at temperatures below 31°F.

7. WATER HEATER

Your coach is equipped with a 6 gallon Bowen combination gas-electric water heater. It is located on the left side, near the rear of the coach. An exterior door is provided to give access to the gas controls and the drain valve.

Electric Operation

This heater is equipped with a 1,000 watt, 115-volt element for operation on electrical current. A separate circuit breaker is provided to protect this appliance. The heater is equipped with a power cord and plug that connects to the adjacent receptacle. A convenient "ON-OFF" switch is located on the electrical box, fastened to the heater jacket. It is accessible from inside the trailer. **DO NOT TURN THIS SWITCH ON UNLESS THE HEATING ELEMENT IS COVERED WITH WATER.** Failure to do so may burn out element and void warranty.

Gas Operation

LIGHTING PROCEDURE

1. The water heater should be filled with water, gas bottles should be full and valves open.
2. Gas cock dial (A) should be in "off" position.
3. Wait sufficient length of time to allow gas which may have accumulated in burner compartment to escape, (at least 5 minutes if re-lighting).
4. Turn gas cock dial (A) to "pilot" position.
5. Depress and hold reset button (B) while lighting pilot burner (E). Allow pilot to burn approximately one-half minute before releasing reset button. If pilot does not remain lit, repeat operation allowing longer period before releasing reset button.
6. Turn gas cock dial (A) to "on" position and set temperature dial (C) to desired temperature.
7. To shut down the heater, turn gas cock knob to "off".

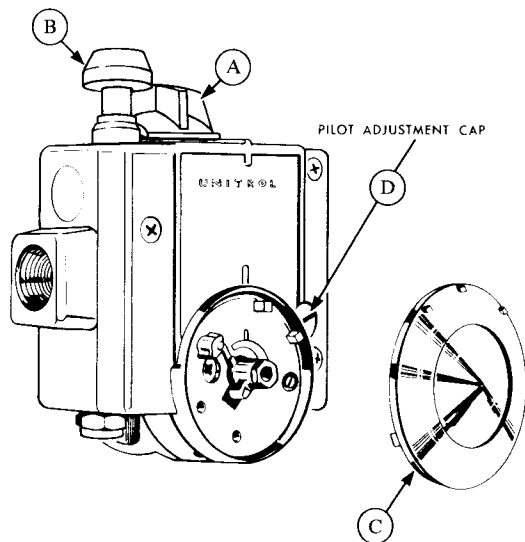

PILOT AND MAIN BURNER ADJUSTMENT

Your BOWEN WATER HEATER has been adjusted at the factory with proper air and gas mixture for both pilot and main burner. Should it be necessary to change these adjustments, use the following procedure:

1. **Pilot Adjustment:** Adjust pilot flame to $\frac{1}{2}$ " high or until a slight yellow tip appears in pilot flame. Pilot adjusting key is located beneath the pilot adjusting cap (Item D).
2. **Gas Line Venting:** When unit is new or has run out of gas it may be necessary to repeat steps 4 and 5 in the LIGHTING PROCEDURE to remove air in the gas line. It is recommended that appliances such as the range or space heater be lighted first. This assures a supply of gas in the main gas line.
3. **Main Burner Adjustment:** Proper combustion depends on the gas and air mixture at the main burner, this is obtained by sliding the air shutter. A yellow smoking flame indicates a lack of air and noisy hard flame indicates an excess of air. A good method of adjusting the air shutter is to slide the shutter closed enough for yellow tipping to occur on the main burner (not pilot) then slowly open air shutter until yellow tipping is gone, then tighten screw.

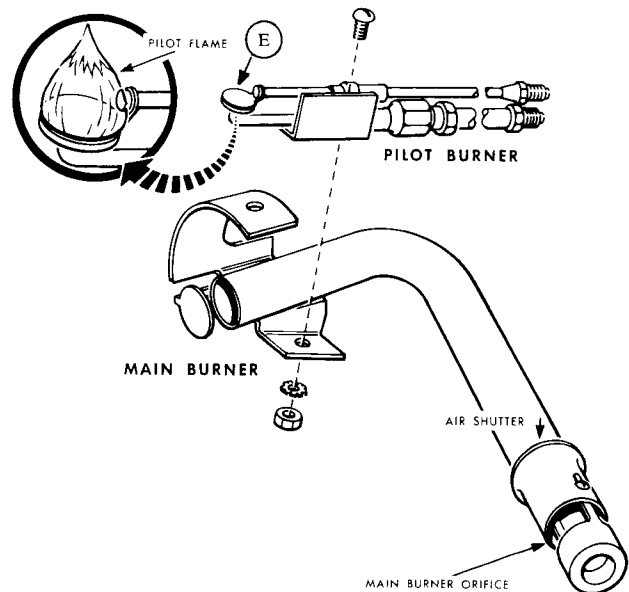

continued on next page

Water Heater (cont'd)

The drain valve is located in the front of the heater. The unit should be drained as required per Section III in this manual.

It is normal for water to drip from the water heater relief valve while water is being heated. The valve is relieving the pressure buildup caused by the expansion of heated water.

The Bowen Model GC6A water heater is warranted by the manufacturer for a period of 12 months, according to the terms of their warranty statement. Consult the warranty sheet for complete details.

Warranty service and parts may be obtained from: **ATWOOD VACUUM MACHINE COMPANY, 1400 Eddy Avenue, Rockford, Illinois 61101.** The telephone number is: AC 815 877-5771. Your coach warranty package includes detailed information on the Bowen warranty and a list of Bowen Service Stations where their work may be performed.

8. GAS FURNACE

All coach models are equipped with Suburban Dyna Trail forced air furnaces. The hot air is carried by ducting to several locations in each trailer. The 22 foot and 25 foot models are equipped with a 22,000 BTU furnace. All other coaches use a 30,000 BTU furnace.

The furnace is installed on the right side of the trailer. Combustion air is taken in and discharged through the trailer wall. Do not restrict the openings.

The furnace controls are located behind the vented cold air return door. To light the furnace, open first the cabinet door and then the metal door on the furnace. Lighting instructions are located on the back side of the metal door, and also explained in detail in the Suburban manual provided in each Owner's Envelope.

To turn the furnace off in warm weather, close the gas line valve and turn the thermostat to the "off" position.

The return air intake is through the perforated access door panel. Do not block the flow of air through this panel. The hot air registers should also be kept clear at all times.

Both furnaces, Model NT-30 and the NT-22 are warranted for a period of **one year** according to the terms noted on the warranty form. Warranty service and parts may be obtained from: **SUBURBAN MANUFACTURING COMPANY, Box 399, Dayton, Tennessee 37321.** The telephone number is: AC 615 775-2131. Collect calls regarding warranty problems will be accepted.

9. WATER CLOSET (TOILET)

Your Avion is equipped with a Thetford Aqua Magic pedal-operated water closet. Operating instructions are as follows:

1. Directions for Automatic Flush and Refill:
 - A. Depress both foot pedals, thus opening the slide valve and dropping the waste into the holding tank. The small pedal turns the water on.
 - B. Keep both foot pedals depressed from one to three seconds until water begins to swirl in the bowl, rinsing it. This short time lag fills the rim storage (for bowl refill) and allows the bowl to drain.
 - C. Release both foot pedals. This closes the slide valve and stops the usage of fresh water. The rim storage now drains and refills the bowl.*
2. Directions for Flushing with the Slide Valve Open a Minimum Amount of Time:
 - A. Depress the small pedal on the right and hold it down until the water begins to swirl in the bowl.
 - B. Release the small pedal.
 - C. Step on the large pedal, thus opening the slide valve and dropping the waste into the holding tank. The water will immediately swirl in the bowl, rinsing it. Note that the large foot pedal carries the small pedal down with it, when it is depressed. The time lag in the flush is eliminated, because the small pedal actuates the water inlet valve; and the rim storage is filled, when both pedals are depressed.
 - D. Release both foot pedals. This closes the slide valve and stops usage of fresh water, and the bowl refills automatically from the rim storage.*
3. Directions for Flushing with the Water Saver Package Installed:
 - A. Hold the hand spray in ready position over the bowl.
 - B. Depress thumb button on the hand spray.
 - C. Depress both foot pedals, thus opening the slide valve, dropping the waste into the holding tank, and sending fresh water through the hand spray.
 - D. Spray the bowl clean with the hand spray. Release the foot pedals, thus closing the slide valve, and shutting off the water flow through the hand spray.*

*Be sure all paper is flushed from the bowl. If wedged in the valve seat, paper will prevent sealing.

continued on next page

Water Closet (Toilet) (cont'd)

The Aqua Magic Toilet does not require lubrication. Ordinary household cleaners may be used for routine cleaning. Common toilet bowl cleansers may be used; however, they should be flushed on through the system within four hours, and should not be left in the holding tank for any extended period of time.

The Thetford Toilet is warranted by the manufacturer for a period of two years, according to the terms and conditions of the Guarantee statement. Warranty service and parts may be obtained from: **THETFORD ENGINEERING CORPORATION, 6539 Jackson Road, Ann Arbor, Michigan 48103.** Their telephone number is AC 313 426-4612.

10. WASTE HOLDING TANK

Your coach is equipped with an Avion molded styrene waste holding tank. This tank is installed with a Thetford valve and cap located on the outside of the coach at the left rear. Close the valve, to retain waste from the toilet, by pushing the valve "T" handle all the way in.

It is not wise to keep the tank valve open. The volume of water used with each flush may not be adequate to flood away all of the solids. The result can be a build-up that becomes hard to remove. Keep the dump valve closed, run about 2" of water in the tank before using and flush every few days.

To flush, open the valve by pulling the "T" handle all the way out. This will send a large volume of sewage through the drain hose at one time, setting up a swirling action that will flush away the solids.

After flushing, run water through the tub or sink drains to dislodge any backed-up sewage that may have been forced into the drain openings.

Waste water from the tub, lavatory and sink will drain through the sewer hose, even when the holding tank valve is closed. Running water through the sink or lavatory drain while the holding tank cap is in place may cause water to back up into the tub. Always remove the cap before using water in the coach.

When preparing to travel, flush and refill with water. Add a commercial cleaner if desired. Be sure that the tank valve is closed and locked with the two wire clips to prevent accidental opening while driving.

When two coaches are traveling together it is sometimes necessary to share water and/or sewage disposal facilities. A standard garden hose "Y" fitting, available at any hardware store, will permit two to share a single water source. Connect the "Y" directly to the coach water inlet faucet. Trailer supply stores can provide a sewage connection "Y" that will also permit sharing a single sewage disposal system.

11. GAS—ELECTRIC REFRIGERATOR

Lighting instructions for the refrigerator are located on the inside of the panel below the refrigerator door. These instructions are duplicated in the Instruction Booklet that is supplied with each unit.

It is important that the refrigerator be level in all directions for proper operation. Place a small level on the freezer shelf and observe with the aid of a small mirror. For leveling instructions refer to Section II of this manual.

For best results operate the refrigerator on "gas". Some locations have wide fluctuations in the line voltage which can cause unsatisfactory operation when switched to "electric".

If your coach is equipped with a 7 cu. ft. refrigerator it will require a little longer to cool the interior when first placed in operation. This initial 5-6 hour cooling period is caused by the unit going through the defrost cycle before starting to cool. This model will automatically defrost the main compartment every 24 hours.

Refrigerator Models RM-45 and RM-60 require periodic manual defrosting. To defrost, turn the thermostat knob to zero (0). Check the drip tray to be sure that it is positioned to collect the melting frost. When defrosting is completed, set the thermostat to the normal position and empty the tray.

Periodic maintenance procedures are described in the Instruction Booklet which is furnished with each refrigerator.

Components in Dometic refrigerators are warranted for various periods from 3 months to 5 years. Refer to the warranty policy, included with each refrigerator, for specific information. Warranty service and parts may be obtained from **DOMETIC SALES CORPORATION, P.O. Box 490, 2900 W. Mishawaka Road, Elkhart, Indiana 46514.** The telephone number is AC 219 523-4510.

On the West Coast contact **WARD & SON, INC., P.O. Box 3505, 15343 Proctor Avenue, City of Industry, California 91744.**

12. RANGE and OVEN

The Magic Chef Range installed in your coach is equipped and adjusted for use with LP gas. To light the range burner hold a lighted match to the edge of the burner orifice ring and turn the burner control knob to the "ON" position. The primary cone of the flame should be approximately 1/2" long. For adjustment instructions refer to the Installation and Service Manual which is provided with each range.

continued on next page

Range and Oven (cont'd)

The range top pilot valve has been turned off at the factory to prevent accidental gas build-up in the coach. Under normal conditions it is best to use a match to light the burners. When stopping for any length of time the top pilot may be turned on for added convenience. **BE SURE THIS VALVE IS TURNED OFF BEFORE LEAVING THE CAMP SITE.** Turn the valve clockwise to close it. Turn only enough to cause the pilot flame to go out. Excessive tightening of the valve screw will damage the seat.

How the Oven System Operates

When the oven thermostat is turned on, gas will flow to the heater pilot, which will be ignited by the constant pilot flame. The flame from the heater pilot will heat the responsive element of the safety valve and open the valve seat allowing gas to flow to the oven burner. The burner then is ignited by the standby pilot flame.

When the oven reaches the set temperature, the thermostat will shut the gas off to the heater pilot, the capillary will cool closing the valve seat and shut off the gas to the oven burner. When the temperature drops, the thermostat will again allow gas to flow to the heater pilot, activating the safety valve and allow the oven burner to be relit. This action will continue throughout the cooking period.

Oven Lighting Procedure

- A. The shut off valve for the Safety Control gas supply line is located on the oven control. Depress the oven control knob and turn counterclockwise to the "OFF" position. This will allow gas to flow to the constant pilot.
- B. Light the Constant Pilot. This is the small tube located at the back of the oven, just to the right of the main oven burner. Use a match or straw to introduce a flame to the end of the pilot tube. See illustration at right.
- C. Turn the oven Control Knob to 300° F. temperature setting on the dial. This will allow gas to flow to the heater Pilot Tube, to be ignited by the Constant Pilot.

The Range Oven is equipped with a safety ignition system that requires a minimum of 30 seconds to operate after turning the oven knob on.

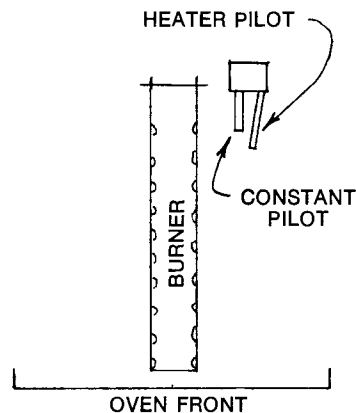

After the oven burner has lighted, set the control knob to the desired temperature. Turn the oven control knob to "OFF" when the oven is not in use. This will allow the constant pilot flame to burn while the coach is parked.

To turn off the constant pilot, depress the control knob and turn clockwise to the "PILOT OFF" position. **ALWAYS PLACE THE CONTROL KNOB IN THE "PILOT OFF" POSITION WHEN TOWING THE COACH.**

The Magic Chef model 728DR Range is warranted to the original purchaser for a period of **90 days** according to the terms of the warranty policy. Warranty service and parts may be obtained from: **MAGIC CHEF, INCORPORATED, 3333 Hammond Avenue, Elkhart, Indiana 46515.** The telephone number is: AC 219 264-9578.

On the West Coast you may contact **MAGIC CHEF, INCORPORATED, PAN PACIFIC DIVISION, 245 North Vineland, City of Industry, California 91744.**

13. RANGE HOOD

The Range Hood is equipped with a filter, fan and side-wall duct to filter and discharge fumes and cooking odors from the coach. The filter may be removed for cleaning by sliding it out. A 12-volt lamp provides illumination of the cooking area. This lamp uses a 25 watt, 12-volt standard base bulb.

14. RUNNING GEAR

Suspension

Avion Coaches are equipped with Smooth-Glide suspension. The rubber springs require no lubrication. They may be washed with soap and water to remove road dirt.

Wheels

The wheels on each coach are electronically balanced on the drums. Should it be necessary to remove a wheel from a drum, place a reference mark on both parts so that the wheel may be remounted in the original position. This precaution will maintain the factory balance, as long as the tire is not removed from the wheel.

The tandem running gear is equipped with chain hooks which make it possible to change a flat tire without the aid of a jack, or to "chain" the axle so that you can drive with the tire left on, or removed, to a tire repair station. For instructions on how to use this exclusive feature see "Flat Tire" in Section V of this manual.

continued on next page

