

TAG RACING INTERNATIONAL™



Manufacturer Address

Motori Seven

Via Perticara 130

47023 Cesena (fc) Italy

125cc TAG Engine

Manufacturer Motori Seven	
Make	
Model Tag L4	
Inlet type Carburetor Dell'orto ø 30	
Number of pages 11	

PICTURE OF ENGINE

(insert picture of front/left here)



(insert picture of back/right here)



Official Signature and Stamp

Importer Cambrian Go Karts, 599 East McGlincy Lane Campbell, CA 95008 408.377.527



TECHNICAL INFORMATION

A CHARACTERISTICS		
	Measurement	Tolerances
Volume of cylinder	124.58 cm ³	125 cm ³
Original bore	54.00 mm	
Theoretical maximum bore	54.08 mm	
Stroke	54.40 mm	
Cooling system	Water cooled	
Number of carburation systems	1	
Number of transfer ports / ducts, cylinder / sump	5	
Number of exhaust ports / ducts	3	
Shape of the combustion chamber	Spherical – with squish	
Length between axes of the connecting rod	110	
Minimum weight of connecting rod		+/- 0.1 mm
Volume of combustion chamber	9	
Type of bearings and size	(example) 6205 type Big End of Con. Rod Bearing = 20 X 26 X 15 Little End of Con. Rod Bearing = 15 X 19 X 20 Crankshaft Bearing = 25 X 52 X 15	

B OPENING ANGLES		
Exhaust	182	
Of exhaust ports / ducts	128-135	

C LIST OF ACCESSORIES INCLUDED		
(List accessories as shown below)	Centrifugal clutch	YES
Carburetor dell'orto ? 30		
Generator for battery charging	NO	
Electric starter	YES	
Exhaust with flex	NO	

D MATERIAL	
Cylinder	Aluminium AL-SI
Connecting rod	Steel Ni cr mo
Crankshaft	Steel Ni cr mo
Head	Aluminium AL-SI
Liner	Aluminium + nicasil
Crankcase	Aluminium AL-SI
Piston	Aluminium AL-SI
Piston Ring	



DRAWING OF THE CYLINDER DEVELOPMENT

(Insert drawing here)

Chord reading

$$B = 52.8$$

$$C1 = 21.7$$

$$C2 = 21.7$$

Angular reading by inserting a 0.2mm gauge

$$E = 33.2$$

$$F = 44.3$$

$$G = 44.3$$

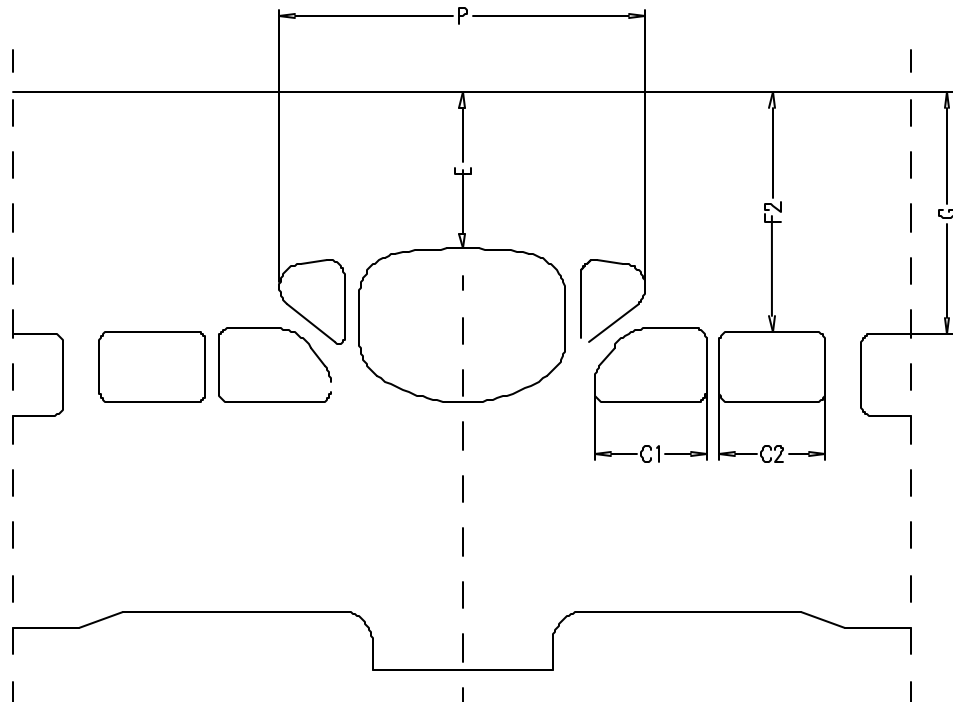

DRAWING OF THE CYLINDER BASE

CYLINDER SECTION VIEW

(Insert drawing here)

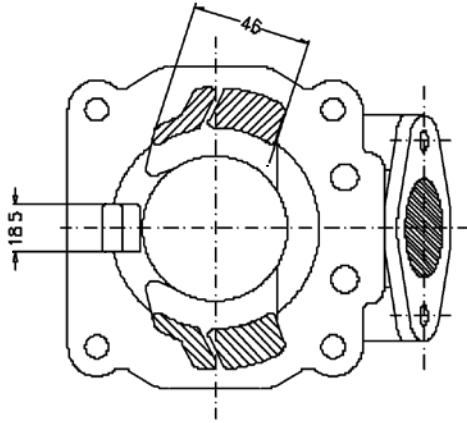

(Insert drawing here)

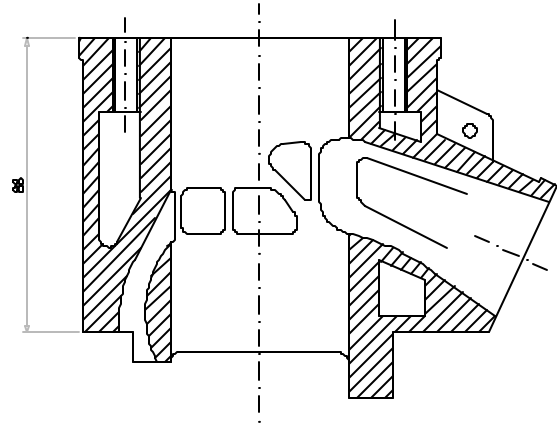



DRAWING OF THE CYLINDER HEAD AND THE COMBUSTION CHAMBER

(Insert drawing here)

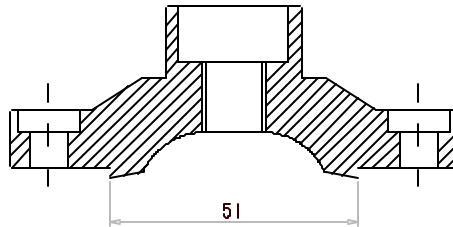

Combustion chamber volume = 9 c.c. minimum

DRAWING OF THE CRANKSHAFT

(Insert drawing here)

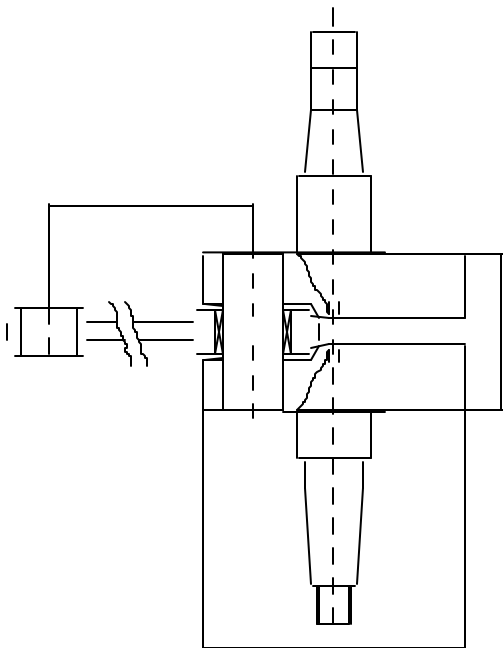





DRAWING OF THE INSIDE OF SUMP

(Insert drawing here)



Complete weight = Kg 2,230 Tolerance= \pm gr100



IGNITION	
Manufacturer Selettra o PVL	
Model Number 06000160	
Rotation P 3356	
Description	
PHOTO OF IGNITION	PHOTO OF COIL
<i>(insert photo of inside here)</i>	<i>(Insert photo here)</i>
	
	



CARBURETOR DIMENSION

(Insert drawing here)

Item
Measure
Tolerance

A = 58,5

B = 30

C = 30

D = 88.5

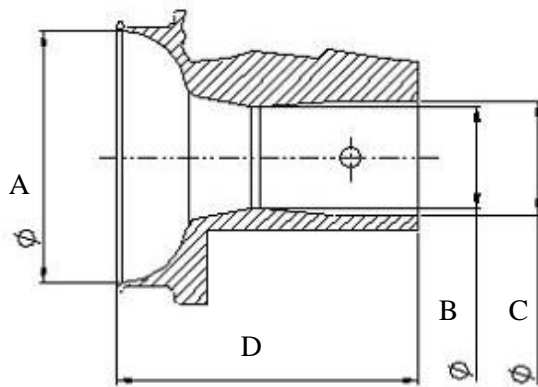

PISTON

CONNECTING ROD

(Insert drawing here)

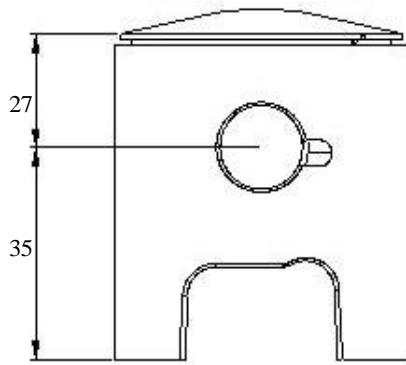

Weight= 116 gr Tolerance= ± 5 gr

(Insert drawing here)

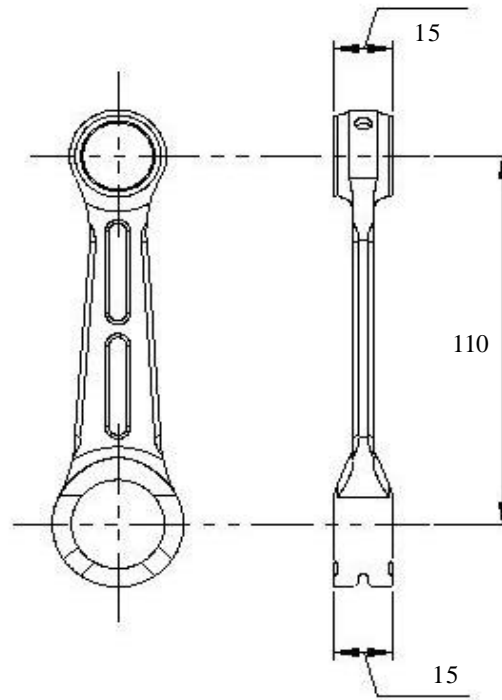

Weight= 130 gr Tolerance= ± 10 gr



DRAWING OF THE SILENCER AND IT'S COMPONENTS

(Insert drawing here)

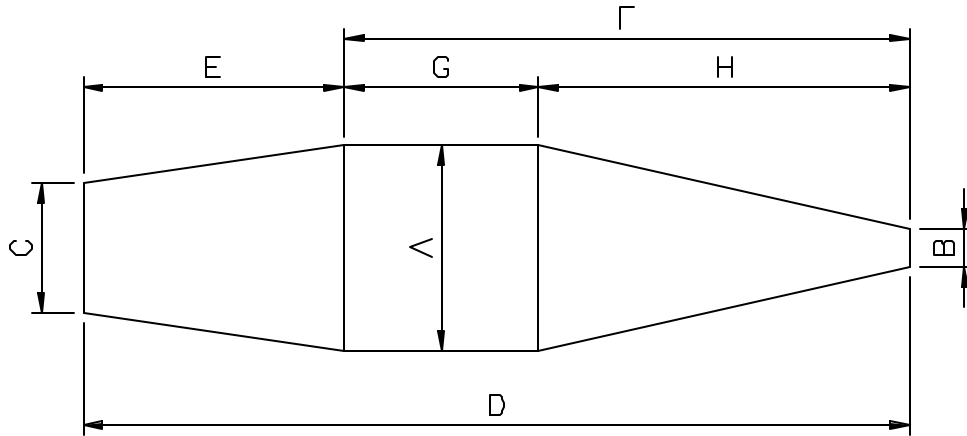

The end parts of the silencer must have two soldered pairs of lugs (one pair at the top and one pair at the bottom) to allow for fixing of seals by the Organizer so that the silencer may be opened during the competition

Measurements:

- A: 105
- B: 20
- C: 66.5
- D: 424
- E: 133.5
- F: 290.3
- G: 100
- H: 190.3



DRAWING OF THE SILENCER

(Insert drawing here)

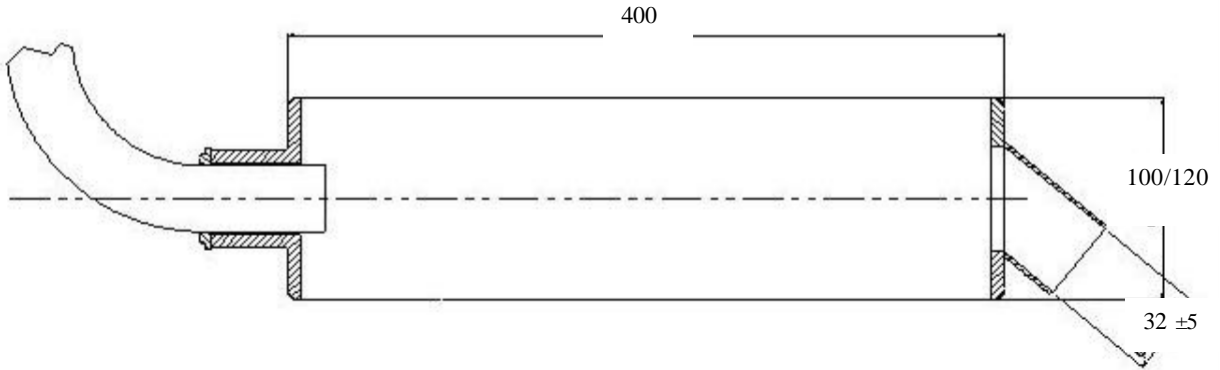

DRAWING OF THE SILENCER

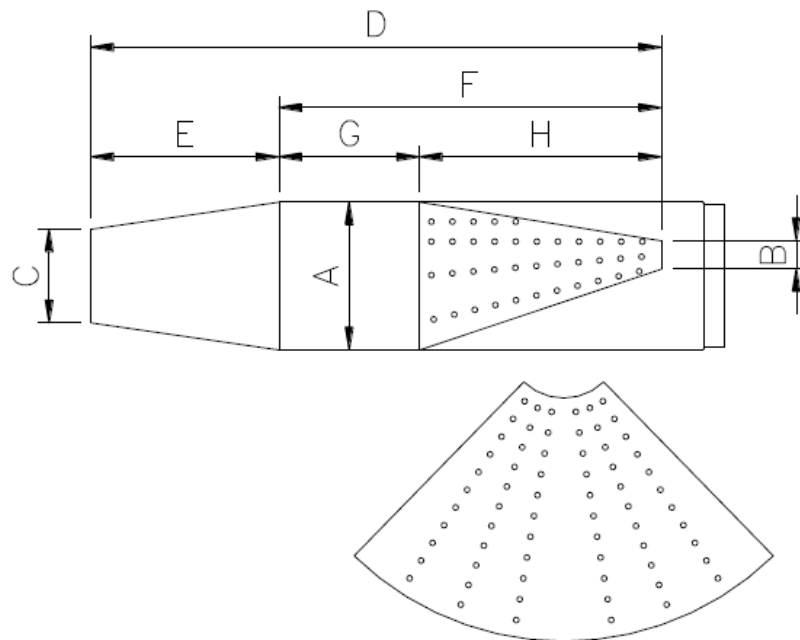

Measurements: mm – tolerances ± 1 mm

- A: 115 B: 20
- C: 66.5 D: 405.5
- E: 133.5 F: 272
- G: 100 H: 172

Motori Seven, L4 TAG Engine

DRAWING OF THE CLUTCH

Item
Weight
Tolerance

A = 127

B = 105.5

C = 114

