

BRAINY 24

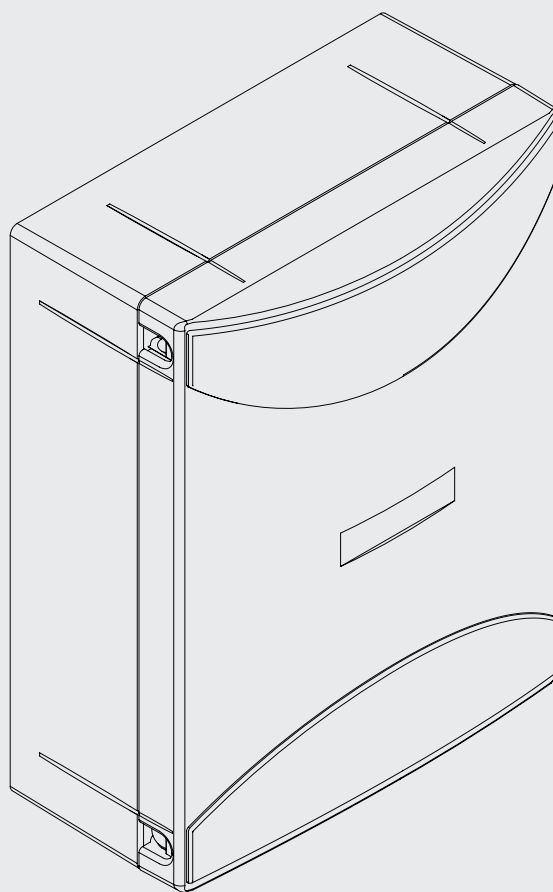

BENINCA[®]
TECHNOLOGY TO OPEN

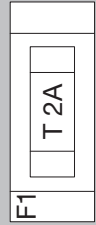

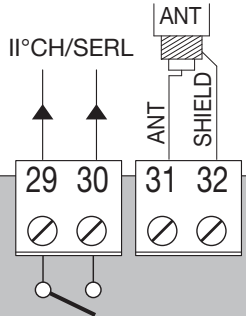
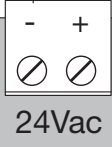
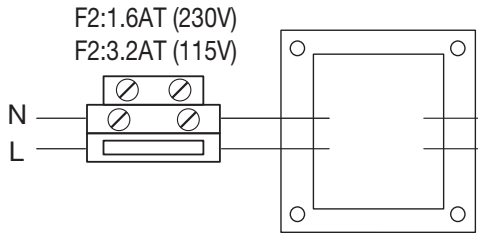

Code

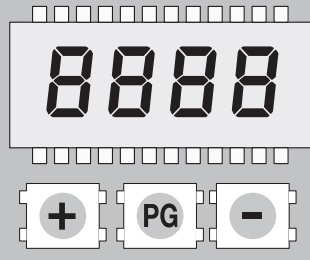

RADIO

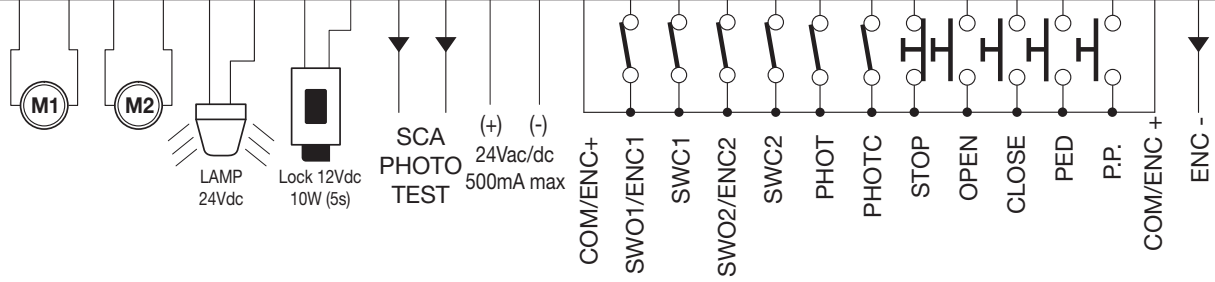
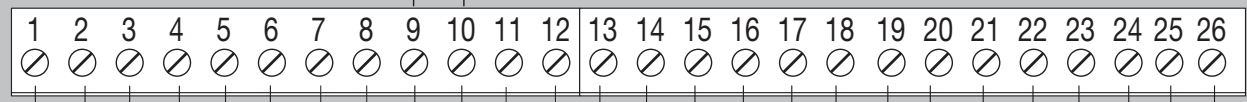
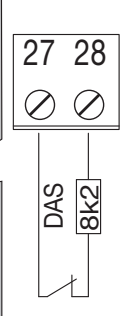
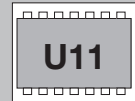
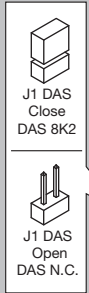

2

**Collegamento ENCODER
ENCODER WIRING**

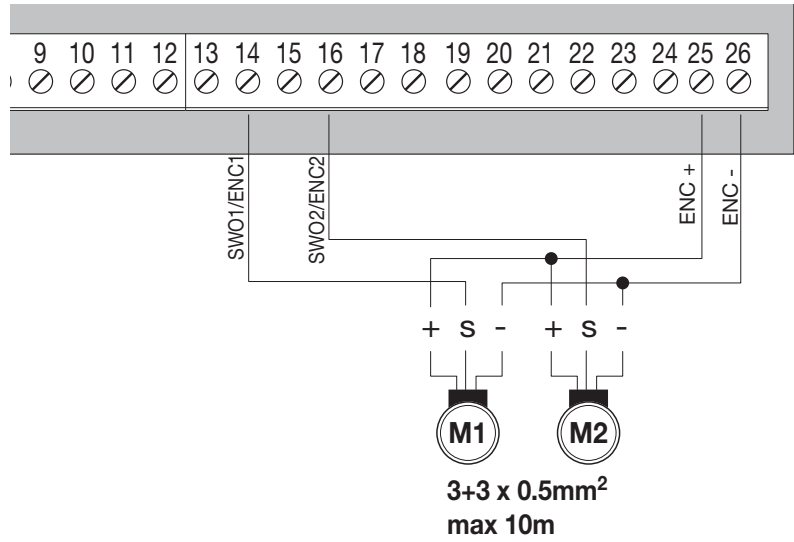

3

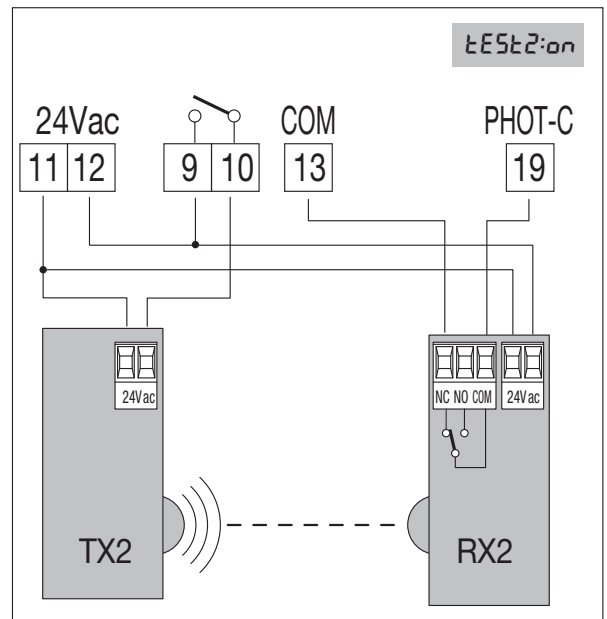
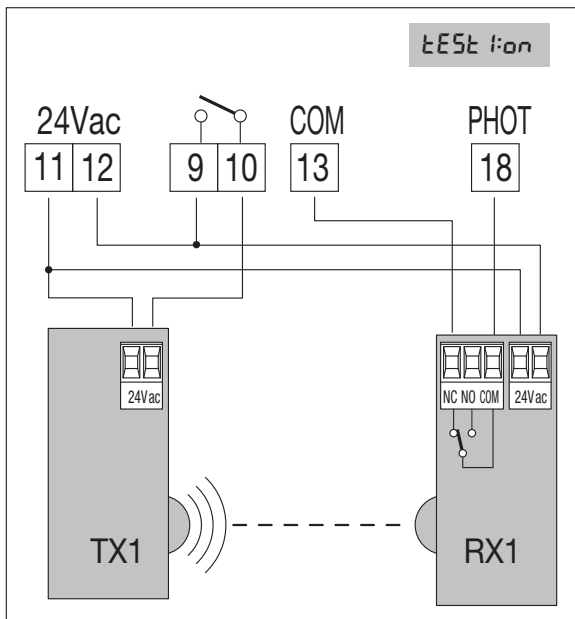

4

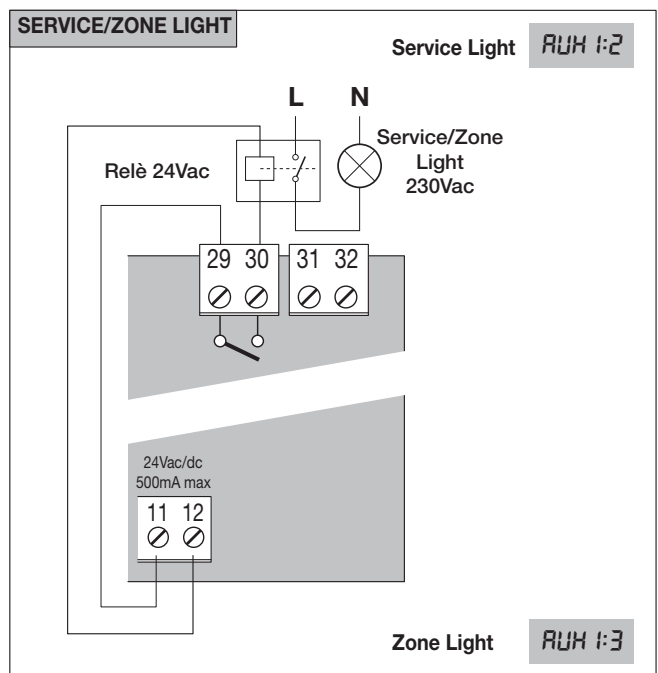
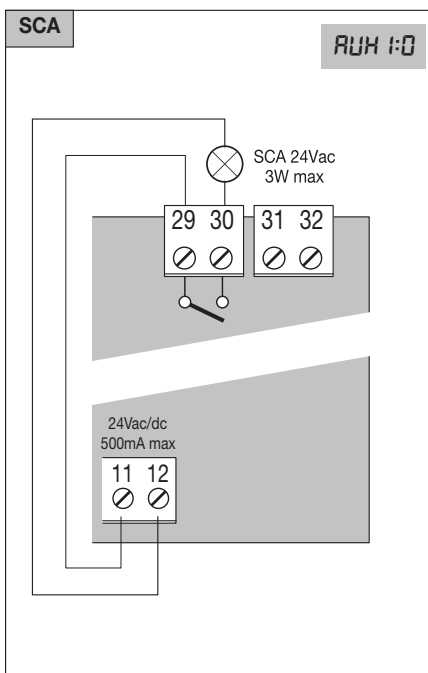

EC Declaration of conformity

Declaration pursuant to Directives 2004/108/EC(EMC); 2006/95/EC(LVD)

Manufacturer:

Automatismi Benincà SpA

Address:

Via Capitello, 45 - 36066 Sandrigo (VI) - Italy

Declares that the product:

Command central for 1 24Vdc motor, for single or sliding doors: BRAINY 24

is compliant with the conditions of the following EC Directives:

• **DIRECTIVE 2004/108/EC OF THE EUROPEAN PARLIAMENT AND COUNCIL** of December 15 2004 regarding the approximation of the legislations of the member States relative to electromagnetic compatibility and that repeals directive 89/336/CEE, according to the following concurred norms:

EN 61000-6-2:2005, EN 61000-6-3:2007.

• **DIRECTIVE 2006/95/EC OF THE EUROPEAN PARLIAMENT AND THE COUNCIL** of December 12 2006 concerning the approximation of the legislations of the member States relative to electrical material destined to be used within certain voltage limits, according to the following concurred regulations:

EN 60335-1:2002 + A1:2004 + A11:2004 + A12:2006 + A2:2006 + A13:2008; EN 60335-2-103:2003.

if applicable :

• **DIRECTIVE 1999/5/EC OF THE EUROPEAN PARLIAMENT AND THE COUNCIL** of March 9 1999 regarding radio devices and terminal and telecommunications devices and the reciprocal recognisances of their conformity, according to the following concurred regulations: ETSI EN 301 489-3 V1.4.1 (2002) + ETSI EN 301 489-1 V1.4.1 (2002) + ETSI EN 300 220-3 V1.1.1 (2000) + EN 60950-1 (2001)

Benincà Luigi, Legal manager.

Sandrigo, 02/11/2010.

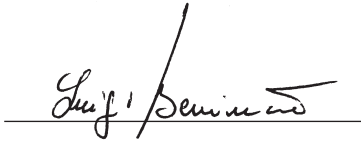

WARNINGS

This manual has been especially written to be use by qualified fitters.

None of the information provide in this manual can be considered as being of interest for the end users.

Preserve this manual for future needs.

The technician has to furnish all the information related to the step by step function, the manual and the emergency function of the operator, and to deliver the manual to the final user.



Foresee on the supply net an onnipolar switch or selector with distance of the contacts equal or superior to 3 mms.

Verify that of the electrical system there is an awry differential interrupter and overcurrent protection.

Some typologies of installation require the connection of the shutter to be link at a conductive mass of the ground according to the regulations in force.

The electrical installation and the operating logic must comply with the regulations in force.

The leads fed with different voltages must be physically separate, or they must be suitably insulated with additional insulation of at least 1 mm.

The leads must be secured with an additional fixture near the terminals.

During installation, maintenance and repair, interrupt the power supply before opening the lid to access the electrical parts

Check all the connections again before switching on the power.

The unused N.C. inputs must be bridged.

The descriptions and the present illustrations in this manual are not binding. Leaving the essential characteristics of the product unchanged, the manufacturer reserves himself the right to bring any change of technical, constructive or commercial character without undertaking himself to update the present publication.

TECHNICAL DATA

Control unit supply	24 Vdc
Power supply	230 Vac 50/60 Hz or 115Vac 50/60Hz according to the version
Output supply	1/2 motor 24Vdc
Maximum motor current	5+5 A
Output supply accessories	24Vdc 500mA max.
Protection level	IP54
Operating temp.	-20°C / +70°C
Radio receiver	built in 433,92 MHz configurable (rolling-code or programmable + rolling-code)
Rolling code transmitters supported	64

IMPORTANT:

The control unit is equipped with an Autoset function to automatically set the main functioning values based on the type of installation.

Terminal No.	Function	Description
1-2	Motor 1	Connection, motor 1: 24VDC 5A max
3-4	Motor 2	Connection, motor 2: 24VDC 5A max
5-6	Flashing light	Connection, flashing light 24VDC 15W max.
7-8	Lock	Output, 12Vdc/10W power supply for electric lock (7:0V, 8:+12V)
9-10	SCA/ PHOTO TEST	Contact free from N.O. Voltage, may be configured as open gate indicator or photocell test. For use as "Open gate indicator" the TEST1 and TEST2 logics must be OFF For use as photocell test it is sufficient to activate one or both TEST logics and connect the photocells as indicated in Fig.3.
11-12	24 Vac/dc	Output, accessory power supply, 24VAC/0.5A max. IMPORTANT: If the battery charger board is installed, the output (without mains power connected) has a 24Vdc polarised voltage. Make sure the devices are correctly connected (i.e. 11:+24Vdc / 12:-0Vdc).
13	COM/ENC+	Common for limit switch and all the command inlets or encoder power supply.
14	SWO1/ENC1	Motor 1 OPEN limit switch input (N.C. contact) or Motor 1 Encoder connection.
15	SWC1	Motor 1 CLOSE limit switch input, (N.C. Contact)
16	SWO2/ENC2	Motor 2 OPEN limit switch input, (N.C. Contact) or Motor 2 Encoder connection.
17	SWC2	Motor 2 CLOSE limit switch input, (N.C. Contact)
18	PHOT	Input, photocell activated in both opening and closing phases
19	PHOT C	Input, photocell activated in closing phase only (Normally closed contact)
20	STOP	Input, STOP push-button (Normally closed contact)
21	OPEN	Input, OPEN push-button (Normally open contact). It is possible to connect a timer for opening in time slots.
22	CLOSE	Input, CLOSE push-button (Normally open contact)
23	PED	Pedestrian button input (N.O. Contact), controls the motor 1 opening, see TPED parameter.
24	Step-by-Step	Input, step-by-step push button (Normally open contact)
25	COM/ENC+	Common for Limit switch and all the command inputs or encoder power supply.

26	ENC-	Input for GND Encoder connection (see Fig.2).
27-28	SENSITIVE EDGE (DAS)	Input, sensitive edge contact Resistive edge: "DAS" Jumper closed Mechanical edge: "DAS" Jumper open When the edge is activated, the gate movement is stopped and reversed for about 3s.
29-30	II°CH/SERL	N.O. Contact free from Voltage, may be configured as second radio channel or service light. For use as second radio channel the 2CH logic must be ON. For use as courtesy light the 2CH logic must be OFF.
31-32	Antenna	Connection to the built-in radio receiver card (30-signal/31-screen).
+ / -	24VAC/dc	Input, 24VAC/24VDC power supply. In case of use of plug batteries connect the battery charging card as indicated in the specific installation instructions.
U11	CONFIGURATION MEMORY	Extractable Eprom Memory. Contains all the control unit configurations (logics, parameters, etc.), including the radiotransmitters. In case of faults it is possible to extract Eprom and insert it into a different control unit, avoiding reprogramming.

ENCODER WIRING

In case the motor is with Encoder and one wished to connect it to the control unit, carry out the connections indicated in Fig.2, in this case the SWO1 and SWO2 inputs may not be used as Limit switch inputs.
It is not possible to use the Encoder and the closure Limit switch simultaneously.
Leave SWC1 and SWC2 shorted.

TO CHECK CONNECTIONS

- 1) Cut-off power supply.
- 2) Manually release the wings, move them to approx. half-stroke and lock them again.
- 3) Reset power supply.
- 4) Send a step-by-step control signal by pressing the <-> push-button.
- 5) **The leaves must move in OPENING.**
In case this does not happen, it is sufficient to invert among them the motor run wires. (1<->2 for M1 motor, and 3<->4 for M2 motor) and, if used, the relative Limit switch inputs (14<->15 for M1 motor, and 16<->17 for M2 motor).

PROGRAMMING

The programming of the various functions of the control unit is carried out using the LCD display on the control unit and setting the desired values in the programming menus described below.
The parameters menu allows you to assign a numerical value to a function, in the same way as a regulating trimmer.
The logic menu allows you to activate or deactivate a function, in the same way as setting a dip-switch.
Other special functions follow the parameters and logic menus and may vary depending on the type of control unit or the software release.

TO ACCESS PROGRAMMING:

- 1 - Press the button <PG>, the display goes to the first menu, Parameters "PAR".
- 2 - With the <+> or <-> button, select the menu you want (PAR>LOG>RAD>NMAN>MACI>RES>AUTO>CODE).
- 3- Press the button <PG>, the display shows the first function available on the menu.
- 4 - With the <+> or <-> button, select the function you want.
- 5 - Press the button <PG>, the display shows the value currently set for the function selected.
- 6 - With the <+> or <-> button, select the value you intend to assign to the function.
- 7 - Press the button <PG>, the display shows the signal "PRG" which indicates that programming has been completed.

NOTES:

Simultaneously pressing <+> and <-> from inside a function menu allows you to return to the previous menu without making any changes. Hold down the <+> key or the <-> key to accelerate the increase/decrease of the values.
After waiting 120s the control unit quits programming mode and switches off the display.
When the board is switched on, the software version is displayed for around 5 sec
Hold down the <+> key or the <-> key to accelerate the increase/decrease of the values.

PARAMETERS, LOGIC AND SPECIAL FUNCTIONS

The tables below describe the individual functions available in the control unit.

PARAMETERS (PAR)			
MENU	FUNCTION	MIN-MAX-(Default)	MEMO
TCR	Automatic closing time. Active only with logic "TCA"=ON. At the end of the set time the control unit orders a closing manoeuvre.	1-240-(40s)	

tN1	Operating Speed - MOTOR 1 Ajustment of the ratio of fast run time and slow down time - i.e: With Encoder motors this is a percentage - so 85 gives 85% fast time / 15% slow time. With Limit Switch motors this figure denotes seconds not % - so 5 gives 5 sec's fast time and the remaining time in slow down.	0-99-(5s)	
tN2	Operating Speed - MOTOR 2 Ajustment of the ratio of fast run time and slow down time - i.e: With Encoder motors this is a percentage - so 85 gives 85% fast time / 15% slow time. With Limit Switch motors this figure denotes seconds not % - so 5 gives 5 sec's fast time and the remaining time in slow down.	0-99-(5s)	
tPEd	Adjusts the motor 1 opening percentage (pedestrian function). With Encoder equipped motors the value is expressed in a percentage (99% mean complete opening cycle). With the motors without Encoder or electrical Limit switch, the value is expressed in seconds.	1-99 (50%)	
PNo1	The anti-crash device* (amperometric sensor) operation is adjusted in the opening phase, at normal speed - Motor 1.	1-99-(50%)**	
PNc1	The anti-crash device* (amperometric sensor) operation is adjusted in the closing phase, at normal speed - Motor 1.	1-99-(50%)**	
PNo2	The anti-crash device* (amperometric sensor) operation is adjusted in the opening phase, at normal speed - Motor 2.	1-99-(50%)**	
PNc2	The anti-crash device* (amperometric sensor) operation is adjusted in the closing phase, at normal speed - Motor 2.	1-99-(50%)**	
tDNo	Mot.2 opening delay time. Regulates the delay time of motor 2 on opening with respect to motor 1	0-15-(2s)	
tDNc	Mot.1 closing delay time Regulates the delay time of motor 1 on closing with respect to motor 2	0-40-(3s)	
tLS	SERL contact activation time (Service light) 29/30 terminals. At each manoeuvre the contact closes for the set time. See Figure 4 connection scheme.	1-240-(60s)	
tLoc	Electric lock activation time. The value is expressed in 1/10s (0=0s - 50=5s)	0-50 (5=0,5s)	
SLd1	Adjusts motor 1 speed during slowing phases. Value expressed in percentage of normal functioning speed.	30-70 (40%)	
SLd2	Adjusts motor 2 speed during slowing phases. Value expressed in percentage of normal functioning speed.	30-70 (40%)	
SPd1	Adjusts motor 1 speed during normal speed phase. Value expressed in percentage.	30-99 (99%)	
SPd2	Adjusts motor 2 speed during normal speed phase. Value expressed in percentage.	30-99 (99%)	
PSo1	The anti-crash device* (amperometric sensor) operation is adjusted in the opening phase, at reduced speed - Motor 1.	1-99-(20%)**	
PSc1	The anti-crash device* (amperometric sensor) operation is adjusted in the closing phase, at reduced speed - Motor 1.	1-99-(20%)**	
PSo2	The anti-crash device* (amperometric sensor) operation is adjusted in the opening phase, at reduced speed - Motor 2.	1-99-(20%)**	
PSc2	The anti-crash device* (amperometric sensor) operation is adjusted in the closing phase, at reduced speed - Motor 2.	1-99-(20%)**	
SERU	The intervention threshold of the anti-crashing device (Encoder) during the phase at normal speed is adjusted.* 0:Off-1:minimum sensitivity - 99: maximum sensitivity	0-99-(0%)	Leave unchanged
SERr	The intervention threshold of the anti-crashing device (Encoder) during braking is adjusted* . 0:Off-1:minimum sensitivity - 99: maximum sensitivity	0-99-(0%)	

*** WARNING: AN INCORRECT SETTING OF THESE PARAMETERS MAY RESULT IN AN HAZARD. COMPLY WITH REGULATIONS IN FORCE!**

With motors without limit switch and/or encoder it adjusts the sensitivity of the sensor which causes arrest during slowing phase.

**** 1: minimum force/torque - 99: maximum force/torque**

LOGIC (LCL)			
MENU	FUNCTION	ON-OFF-(Default)	MEMO
<i>tca</i>	Enables or disables automatic closing On: automatic closing enabled Off: automatic closing disabled	(ON)	
<i>ibl</i>	Enables or disables condominium function. On: condominium function enabled. The step-by-step impulse or transmitter impulse has no effect during the opening phase. Off: condominium function disabled.	(OFF)	
<i>ibca</i>	The bloc of flat function is enabled or disabled. On: the bloc of flat function is enabled. The Step-by-Step signal or the transmitter signal has no effect during the TCA counting. Off: the bloc of flat function is disabled.	(OFF)	
<i>scL</i>	Enables or disables rapid closing On: rapid closure is enabled. With open gate, or in the opening phase, the activation of the photocell causes the automatic closure 3sec after the total opening of the gate. It is activated only with TCA:ON Off: rapid closing disabled.	(OFF)	
<i>PP</i>	Selects the operating mode of the "Step by step button" and of the transmitter. On: Operation: OPEN > CLOSE > OPEN > Off: Operation: OPEN > STOP > CLOSE > STOP >	(OFF)	
<i>PrE</i>	Enables or disables pre-blinking. On: Pre-blinking enabled. Blinking is activated 3s before the motor starts. Off: Pre-blinking disabled.	(OFF)	
<i>hAn</i>	Enables or disables the inversion stroke function On: Function enabled. Before each opening or closing manoeuvre the control unit orders a manoeuvre of 2s in the opposite direction to facilitate the release of the electric lock. Off: Function disabled.	(OFF)	
<i>blco</i>	Enables or disables the block function in opening. On: Block function enabled. To use only with motors equipped with Limit switch. After the intervention of the opening Limit switch the control unit delays arrest by about 0.5s, so to allow a better strike of the shutter on the stop locks. Off: Block function disabled	(OFF)	
<i>blcc</i>	Enables or disables the block function in closing. On: Block function enabled. To use only with motors equipped with Limit switch. After the intervention of the opening Limit switch the control unit delays arrest by about 0.5s, so to allow a better strike of the shutter on the stop locks. Off: Block function disabled.	(OFF)	
<i>Soft</i>	Enables or disables start at decreased speed. On: Executes start ups at decreased speed for 2 seconds to then shift to normal speed. Off: Start at decreased speed not active.	(OFF)	
<i>Ltca</i>	Selects the operating mode of the blinking light during the time TCA On: Blinking light on during TCA Off: Blinking light off during TCA	(OFF)	
<i>htr</i>	Enabled or disables HOLD-TO-RUN function On: HOLD-TO-RUN function. The pressure of the OPENS/CLOSES button must be maintained throughout the entire manoeuvre. The opening of the STOP input stops the motor. All the safety inputs are deactivated, except for the Limit switch inputs /SW01/SW02/SWC1/SWC2). Off: Automatic/semiautomatic function	(OFF)	
<i>1Mot</i>	Select the 1/2 motors operating mode: On: Only motor 1 operating. Off: Both motors operating.	(OFF)	
<i>cuAr</i>	The code programmable transmitters is enabled or disabled. On: Radio receiver enabled only for rolling-code transmitters. Off: Receiver enabled for rolling-code and programmable code transmitters (self-learning and Dip Switch).	(OFF)	

<i>nLoc</i>	Selects the type of electric lock used. On: Magnetic electric lock, normally fed at 12Vdc. Before each opening manoeuvre the power supply is interrupted for the time set by the parameter TLOC. Off: Electric lock with latch, normally not fed. Before each opening manoeuvre power is fed at 12Vdc for the time set by the parameter TLOC.	(OFF)	
<i>bb</i>	Inactive on current panel	(OFF)	
<i>2ch</i>	Enables or disables the second radio channel on terminals 29/30. On: Exit 29/30 configured with function as second radio channel. Off: Exit 29/30 takes on function of service light (see parameter TLS).	(OFF)	
<i>t5t1</i>	Enables or disables checking of photocells on PHOT input, active both in closing and in opening. On: Check enabled. If the check has a negative result, no manoeuvre is commanded. See Fig.3 - "PHOTO TEST". Off: Checking of photocells disabled at each manoeuvre.	(OFF)	
<i>t5t2</i>	Enables or disables checking of photocells on PHOT inputs, active only in closing. On: Check enabled. If the check has a negative result, no manoeuvre is commanded. See Fig.3 - "PHOTO TEST". Off: Checking of photocells disabled at each manoeuvre.	(OFF)	
<i>t5t7</i>	Enables or disables motors check. On: Check enabled. If the check has a negative result, no manoeuvre is commanded. Off: Check disabled.	(OFF)	
<i>rEn</i>	(Enables or disables remote radiotransmitters learning, as indicated in the paragraph "Remote transmitters learning". On: Remote learning enabled. Off: Remote learning not enabled.	(OFF)	

RADIO (*rAd*)

MENU	FUNZIONE
<i>pp</i>	By selecting this function, the receiver goes in waiting (<i>PU5h</i>) for a transmitter code to assign to the step-step function. Press the key of the transmitter to assign to this function. If the code is valid, it is memorised and the message <i>oH</i> is displayed If the code is not valid, the message <i>Err</i> is displayed
<i>2ch</i>	By selecting this function, the receiver goes into waiting (<i>PU5h</i>) for a transmitter code to assign to the second radio channel. Press the key of the transmitter to assign to this function. If the code is valid, it is memorised and the <i>oH</i> message is displayed If the code is not valid, the message <i>Err</i> is displayed.
<i>PEd</i>	By selecting this function, the receiver goes into waiting (<i>PU5h</i>) for a transmitter code to assign to the pedestrian opening function (see parameter TPED). Press the key of the transmitter to assign to this function. If the code is valid, it is memorised and the <i>oH</i> message is displayed If the code is not valid, the message <i>Err</i> is displayed.
<i>cLr</i>	By selecting this function, the receiver goes into waiting (<i>PU5h</i>) for a transmitter code to erase from the memory. If the code is valid, it is erased and the message <i>oH</i> is displayed If the code is not valid or not present in memory, the message <i>Err</i> is displayed
<i>rEr</i>	Completely erases memory of the receiver. Confirmation of the operation is requested. By selecting this function the receiver goes into waiting (<i>PU5h</i>) for a new PGM pressure to confirm the operation. At end of erasing the <i>oH</i> message is displayed

CYCLES NUMBER (*nRRn*)

Displays the number of complete cycles (open+close) carried out by the automation.
When the <PG> button is pressed for the first time, it displays the first 4 figures, the second time it shows the last 4. Example
<PG> 00 12 >>> <PG> 3456: made 123.456 cycles.

MAINTENANCE CYCLES (MRC !)

This function enables to activate the maintenance request notice after a number of manoeuvres determined by the installer. To activate and select the number of manoeuvres, proceed as follows:
Press button <PG>, the display will show OFF, which indicated that the function is disabled (default value).
With the buttons <+> and <-> select one of the numeric values proposed (from OFF to 100). The values are intended as hundreds of cycles of manoeuvres (for example: the value 50 indicates 5000 manoeuvres).
Press the OK button to activate the function. The display will show the message *Prœ*.
The maintenance request is noted to the user through flashing of the LEDs of the courtesy light during opening and closing manoeuvre.

RESET (rES)

RESET of the control unit. ATTENTION!: Returns the control unit to the default values.
Pressing the <PG> button for the first time causes blinking of the letters *rES*, pressing the <PG> button again resets the control unit. Note: The transmitters are not erased from the receiver nor is the access password.
All the logics and all the parameters are brought back to default values, it is therefore necessary to repeat the autose procedure.

AUTOSET (Autø)

* See below if a second Autose is required

This function must be used to set the optimal automation function values, and at the end of the procedure, it sets medium values of TORQUE, WORK TIME and SLOWING.
To carry out autose, proceed as follows:
a) Ascertain that no obstacles of any nature are present in the manoeuvre area, if necessary, block off the area in order to prevent access from people, animals, vehicles, etc.
During autose phase, the anti-crushing function is not active.
b) Select the AUTO function and press OK.
c) Select with the <+> or <-> button the submenu, **NLSU, LSW or ENC** based on the presence of Limit switch and/or encoder:
NOLS: if the motor is without Limit switch and encoder
LSW: if the motor is equipped with Limit switch and without encoder
ENC: if the motor is equipped with encoder and without Limit switch
d) once selected press OK to begin the autose phase.
The control unit carries out a series of manoeuvres for learning of the run of the leaves and for parameter configuration. Initially both the leaves are brought to opening position, then after some opening and closing manoeuvres at different speeds, of one or both the shutters, the control unit displays the message *øH*. In case the operation has no positive result, the message *Err* is displayed. Repeat the operation after re-checking the wiring and the eventual presence of obstacles.
In case parameters TM1/TM2 or the speed are changed, repeat the autose procedure.
During the manoeuvres the display will show some abbreviations: OPM1/OPM2 during opening of the motor 1 or 2 and CLM1/CLM2 during closing of motor 1 or 2.

PROTECTION CODE (codE)

It allows to type in an access protection code to the programming of the control unit.
A four-character alphanumeric code can be typed in by using the numbers from 0 to 9 and the letters A-B-C-D-E-F.
The default value is 0000 (four zeros) and shows the absence of a protection code.
While typing in the code, this operation can be cancelled at any moment by pressing keys + and - simultaneously. Once the password is typed in, it is possible to act on the control unit by entering and exiting the programming mode for around 10 minutes in order to allow adjustments and tests on functions.
By replacing the 0000 code with any other code, the protection of the control unit is enabled, thus preventing the access to any other menu. If a protection code is to be typed in, proceed as follows:
- select the Code menu and press OK.
- the code 0000 is shown, also in the case a protection code has been previously typed in.
- the value of the flashing character can be changed with keys + and -.
- press OK to confirm the flashing character, then confirm the following one.
- after typing in the 4 characters, a confirmation message "CONF" appears.
- after a few seconds, the code 0000 appears again
- the previously stored protection code must be reconfirmed in order to avoid any accidental typing in.
If the code corresponds to the previous one, a confirmation message "øH" appears.
The control unit automatically exits the programming phase. To gain access to the Menus again, the stored protection code must be typed in.
IMPORTANT: TAKE NOTE of the protection code and KEEP IT IN A SAFE PLACE for future maintenance operations.
To remove a code from a protected control unit it is necessary to enter into programming with the password and bring the code back to the 0000 default value.
IF YOU LOOSE THE CODE, PLEASE CONTACT THE AUTHORISED SERVICE CENTER FOR THE TOTAL RESET OF THE CONTROL UNIT.

* Autose - A second time ?

If a second Autose procedure is required - First reset the panel using (*rES*) in the menu.
Next - power down, then power up again before using the Autose function a second time.

TRANSMITTERS REMOTE LEARNING

If an already memorised transmitter is available in the receiver it is possible to carry out remote radio learning (without needing to access the control unit).

IMPORTANT: The procedure must be carried out with leaves in opening during TCA pause or with an open gate if the TCA logic is OFF. The REM logic must be ON.

Proceed as follows:

- 1 Press the hidden key of the transmitter which is already memorised.
- 2 Press, within 5s, the key of the corresponding transmitter which is already memorised to associate to the new transmitter. The flashing light will turn on.
- 3 Press within 10s the hidden key of the new transmitter.
- 4 Press, within 5s, the key of the new transmitter to associate to the channel chosen at point 2. The flashing light will turn off.
- 5 The receiver memorised the new transmitter and immediately exits from programming.

FUSES

F1: Accessory power supply safety fuse.

F2: General safety fuse

EMERGENCY BATTERY

An optional accessory is available for control unit power supply in case of absence of power.

The kit is made up of a battery charging board and two 12V rechargeable batteries, fixing clamps, screws and wiring. For further information, refer to the instructions supplied with the accessory.

DIAGNOSTICS

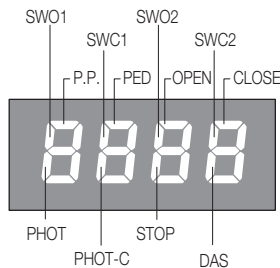

One segment of the display is linked to each input. In the event of failure it switches on according to the following scheme.

N.C. inputs are represented by the vertical segments. N.O. inputs are represented by the horizontal segments.

The control unit sees the message AMP1 or AMP2 in case of anti-crushing ammeter sensor intervention.

ERROR MESSAGES

Some messages that are displayed in case of function anomalies are listed as follows:

<i>AMP1</i>	Obstacle error motor 1/anti-crushing	Check presence of obstacles on motor 1 leaf run
<i>AMP2</i>	Obstacle error motor 2/anti-crushing	Check presence of obstacles on motor 2 leaf run
<i>Err1</i>	Motor 1 circuit checking error	Check motor 1 connections
<i>Err2</i>	Motor 2 circuit checking error	Check motor 2 connections
<i>Err3</i>	error/fault power circuit	Request technical assistance and eventually replace control unit.
<i>Err4</i>	PHOTA photocell checking error	Check connections, PHOT A photocell alignment or presence of obstacles.
<i>Err5</i>	PHOTC photocell checking error	Check connections, PHOTC photocell alignment or presence of obstacles.
<i>Err6</i>	Error edge active (during autaset)	In autaset phase, the safety edge has intervened.
<i>Err7</i>	Error active stop (during autaset)	In autaset phase, the STOP input has intervened.
<i>Err8</i>	Error active input (during autaset)	In autaset phase a PP/Open/Close input has intervened.
<i>thr1</i>	Motor thermal protection intervention	Wait for motor cooling, in case reset does not take place, motor replacement may be necessary

WASTE DISPOSAL

If the product must be dismantled, it must be disposed according to regulations in force regarding the differentiated waste disposal and the recycling of components (metals, plastics, electric cables, etc.). For this operation it is advisable to call your installer or a specialised company.

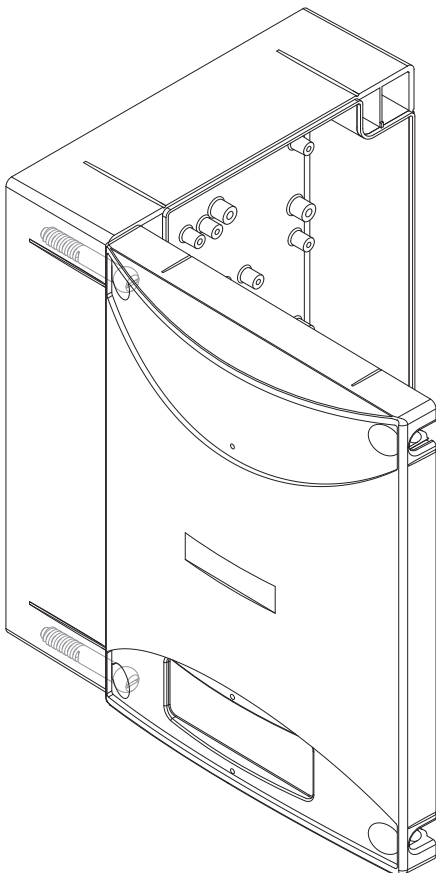
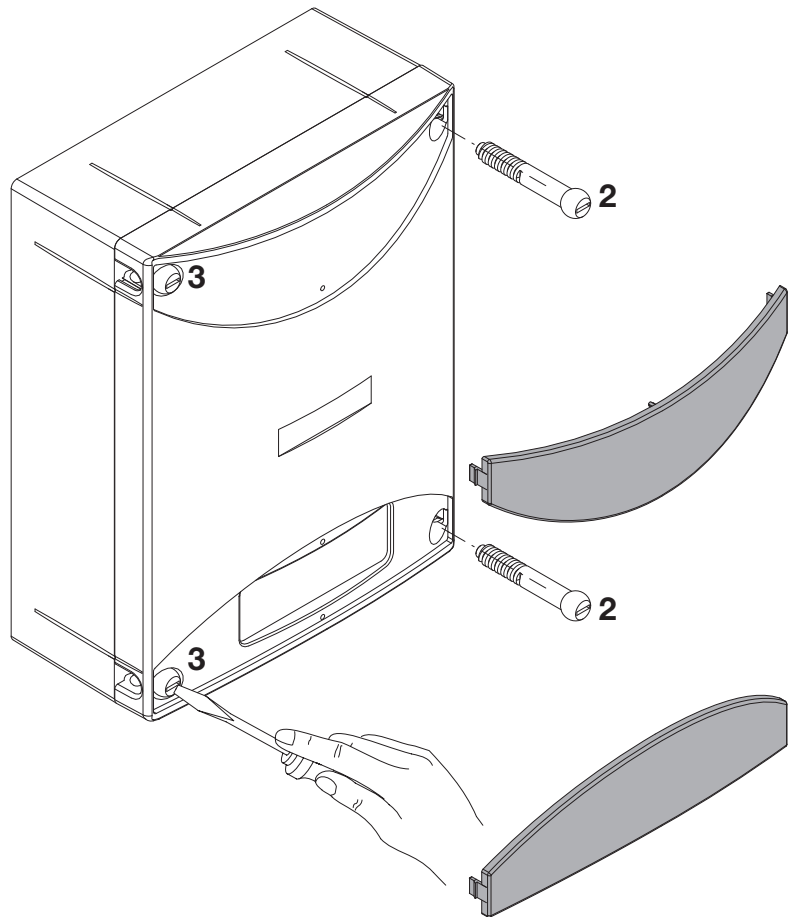
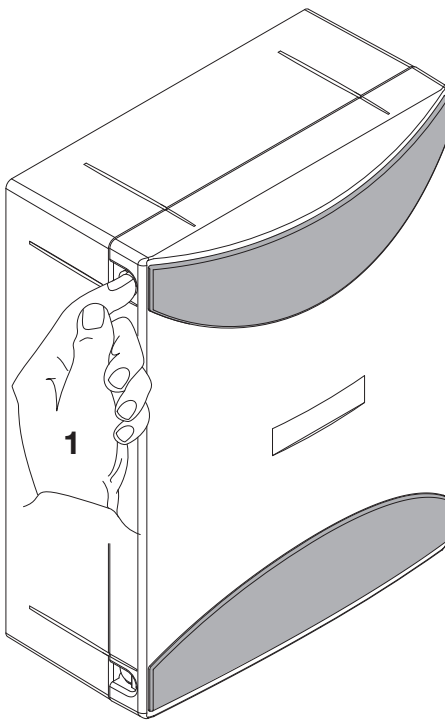

- 1 Premere le alette sui fianchi per sganciare le due maschere copriviti.
- 2 Rimuovere le due viti sul lato di apertura desiderato.
- 3 Allentare le due viti con funzione di cerniera senza rimuoverle, in modo da consentire l'apertura del coperchio.

- 1 Presser les deux ailettes latérales pour décrocher les deux cache-vis.
- 2 Enlever les deux vis sur le côté d'ouverture désiré.
- 3 Desserrer les deux vis faisant fonction de charnière sans les enlever, de manière à permettre l'ouverture du couvercle.

- 1 Press the tabs on the sides to release the two masks that cover the screws.
- 2 Remove the two screws on the desired opening side.
- 3 Slacken the two screws that act as a hinge without removing them, so as to allow opening of the cover.

- 1 Presionar las aletas en los lados para desenganchar las dos tapas cubretornillos.
- 2 Extraer los dos tornillos del lado de apertura deseado.
- 3 Aflojar los dos tornillos con función de bisagra sin extraerlos, a fin de poder abrir la tapa.

- 1 Auf die seitlichen Laschen drücken, so dass die beiden Schraubenblenden befreit werden.
- 2 Die beiden Schrauben an der gewünschten Öffnungsseite ausbauen.
- 3 Zuletzt die beiden als Scharnier dienenden Schrauben lockern, aber nicht ausbauen, damit der Deckel geöffnet werden kann.

- 1 Naciśnąć boczne klapki w celu odhaczenia dwóch masek nakrywających śruby.
- 2 Wyciągnąć dwie śruby po wybranej do otwierania stronie.
- 3 Poluzować dwie śruby blokujące bez wyciągania ich, w sposób umożliwiający otwarcie nakrywki.

BENINCA®