

# Solidworks/2014

## 3D Modelling Tutorial

L3

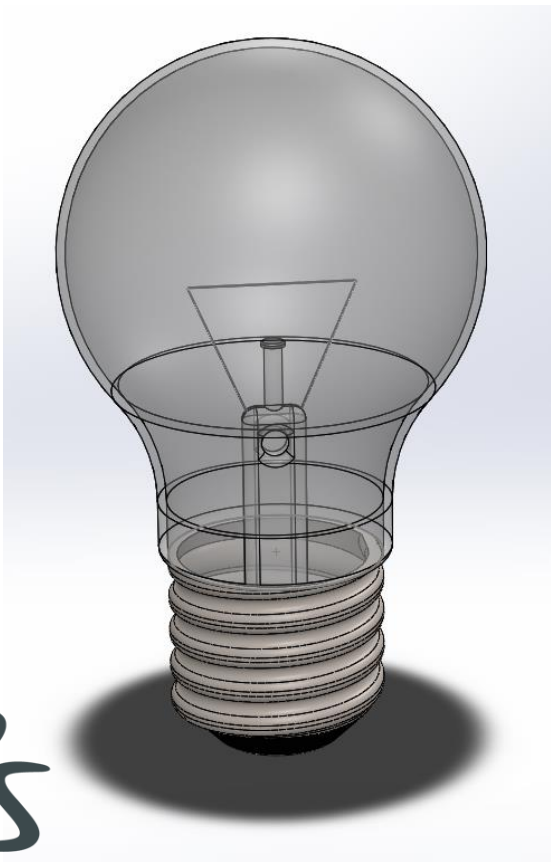

**SOLIDWORKS**

Mr Billington 2014 ©

## Learning Outcome; Light Bulb

### Skill Level; 3 -Advanced

**3D;** *Boss, Helix, Swept cut, Revolve, Fillet, Shell, Render, Extruded cut*

**2D;** *Circle tool, Spline, Helix, Trim Entities*



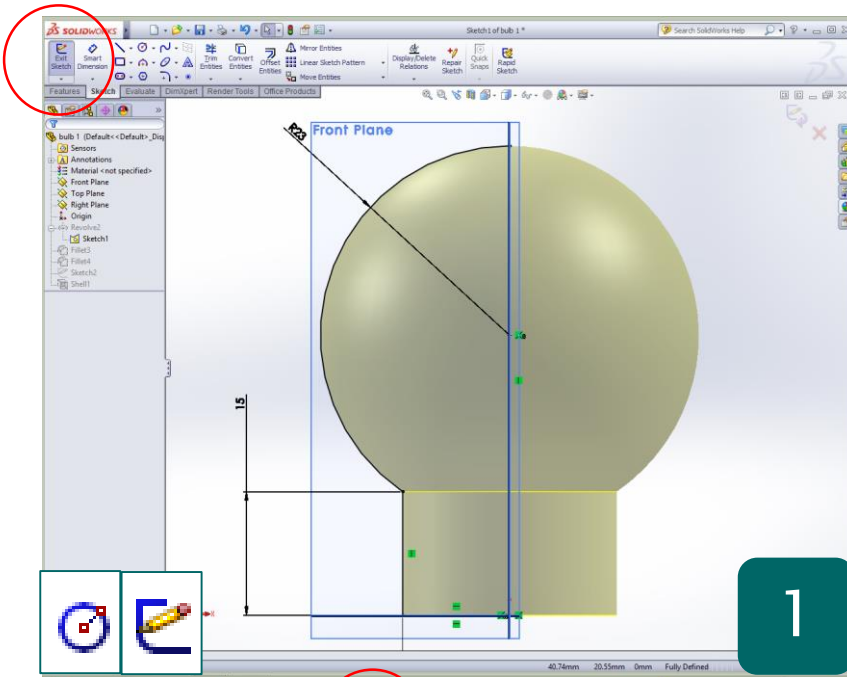

- New > Part File
- Sketch a circle **23mm** from the middle intersecting plane
- Sketch a rectangle starting **42mm** down from the of the circle; **15mm x 13mm**
- **Trim Entities > Power Trim** to remove the excess sketch
- Complete the profile with a centre line
- Select '**Revolved Boss**' in the '**features toolbar**' and revolve profile around axis
- Confirm with the green tick

**Why?** – The revolved boss feature allows for quick generation of rounded geometry and only requires the geometry for half of the profile to be created.

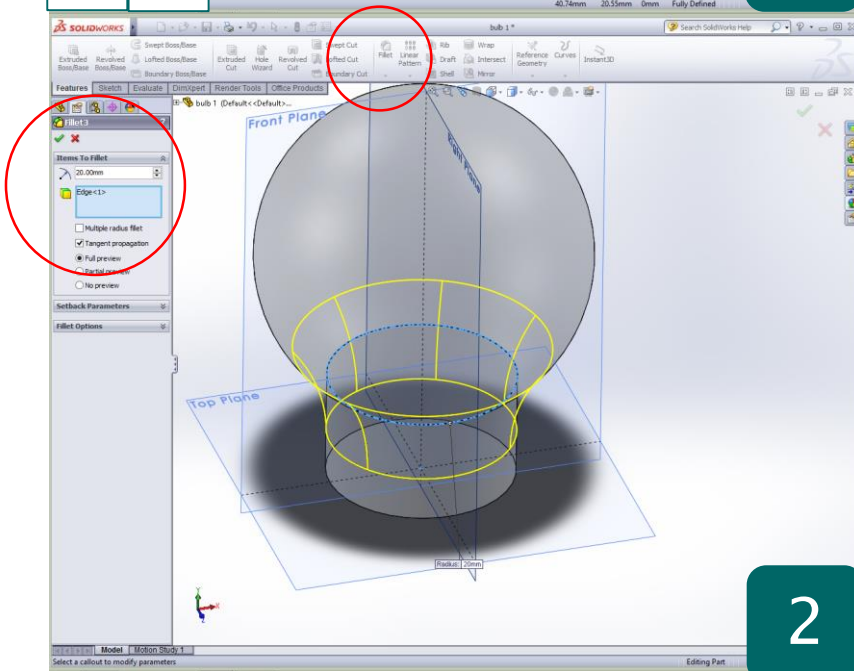

- Use '**Fillet**' in the '**feature toolbar**' and select the joining edge
- Set the Radius to **20mm**
- Confirm with the green tick

**Why?** – Using the fillet tool is an easy way to merge joining geometry and created controlled curved geometry between edges

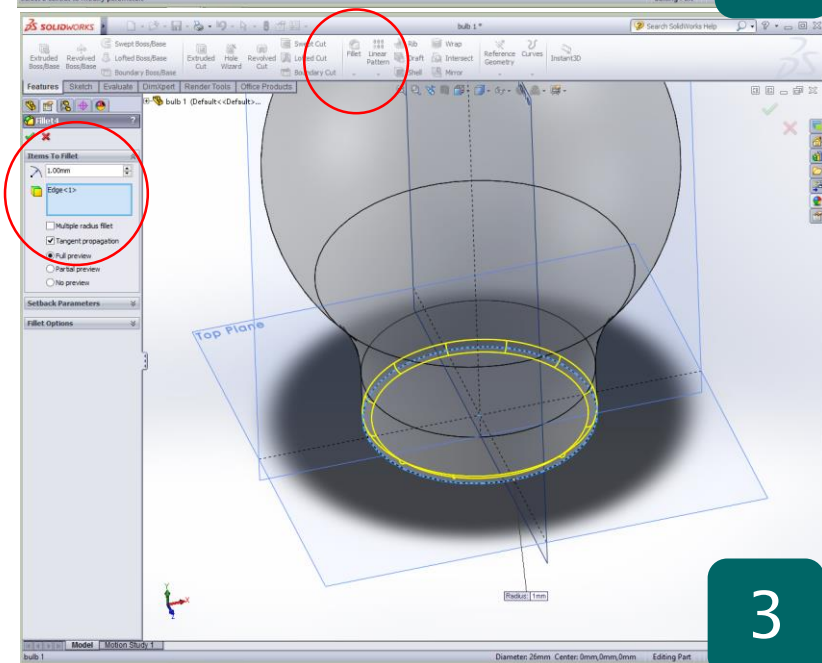

- Apply a slight fillet to the base of the bulb of **1mm** Radius
- This will allow make a seamless join with the base of the bulb when assembled in the final stage

**Why?** - For this tutorial it made sense to produce two separate parts to the bulb to allow for the filament insert to be easily produced along with the threaded base

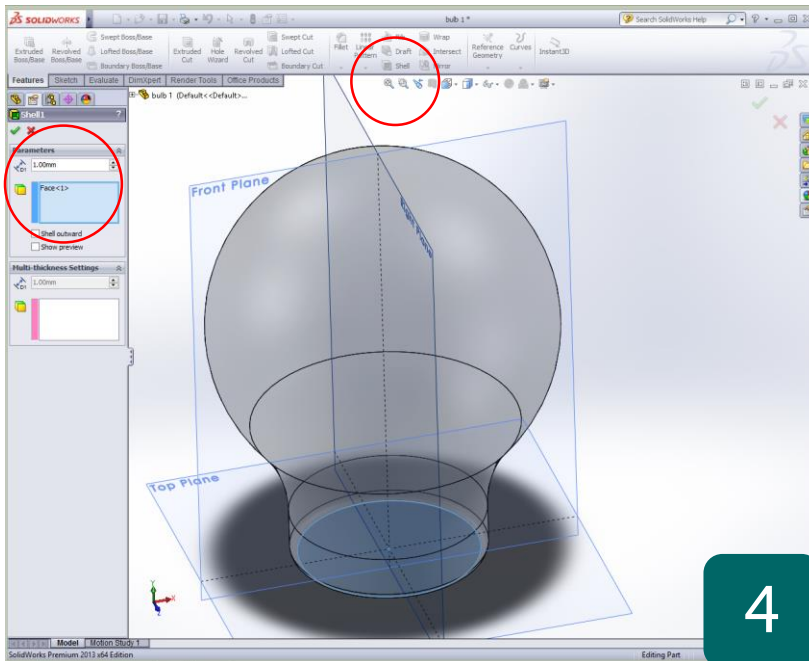

4

- Select '**Shell**' from the '**features toolbar**'
- Select the face at the base of the bulb
- Set the wall thickness to **1mm**
- Confirm with the green tick
- '**Edit Appearance**' and set the model material to '**Glass**'
- Save the file as '**Bulb Top**'

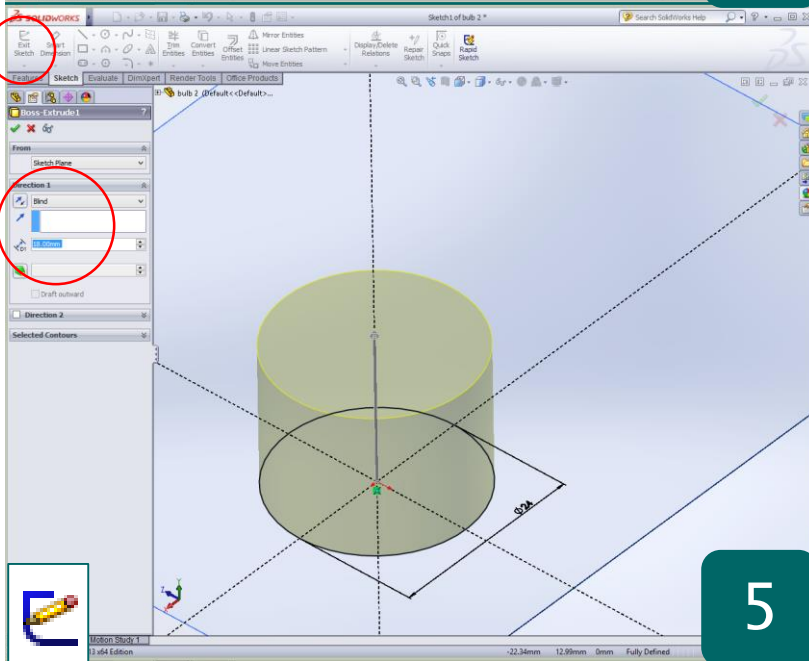

5

- File > New > Part File
- Show all three work planes in the model tree
- Select a work plane and click '**Sketch**'
- Circle tool to create a **12mm** radius circle
- Select '**Extruded Boss**' in the features toolbar and extrude by **18mm**
- Confirm with the green tick

Why? – This will form the base of the bulb and be used to cut the required thread. Most new parts begin with a extrusion and features are used to sculpt it to the required shape.

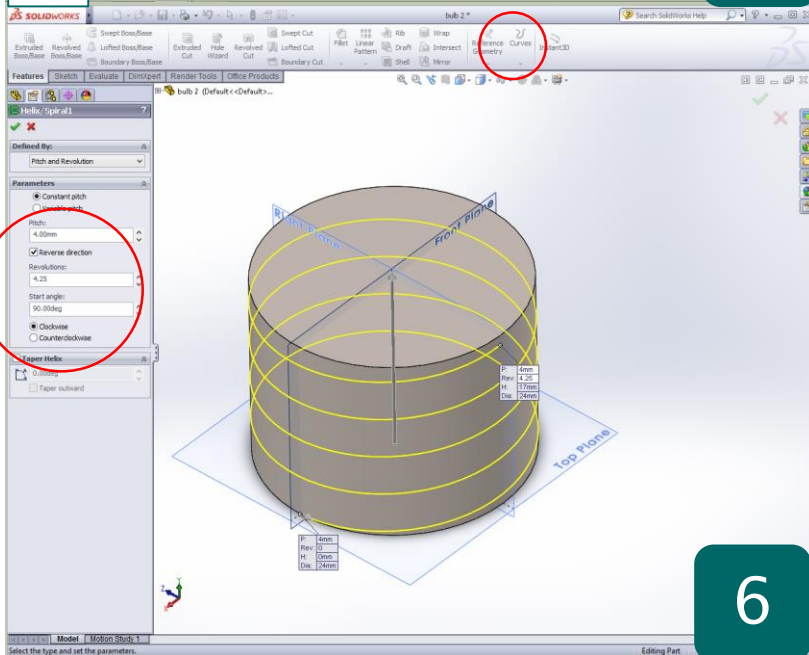

6

- To create the thread the '**helix**' tool is required to generate a 3D path for the profile to follow
- Click '**Curves**' in the '**feature toolbar**'
- Sketch a circle on the base of the cylinder with an identical radius
- **Exit Sketch**
- Set the pitch to **4mm** and the revolutions to **2.25**
- Set a **90** Degree start angle
- Confirm with the green tick if the preview matches the screenshot shown

Why? – As in the bolt tutorial a controlled helix is required to generate the appropriate path. This pitch is only a rough estimate to match the aesthetic of a common light bulb

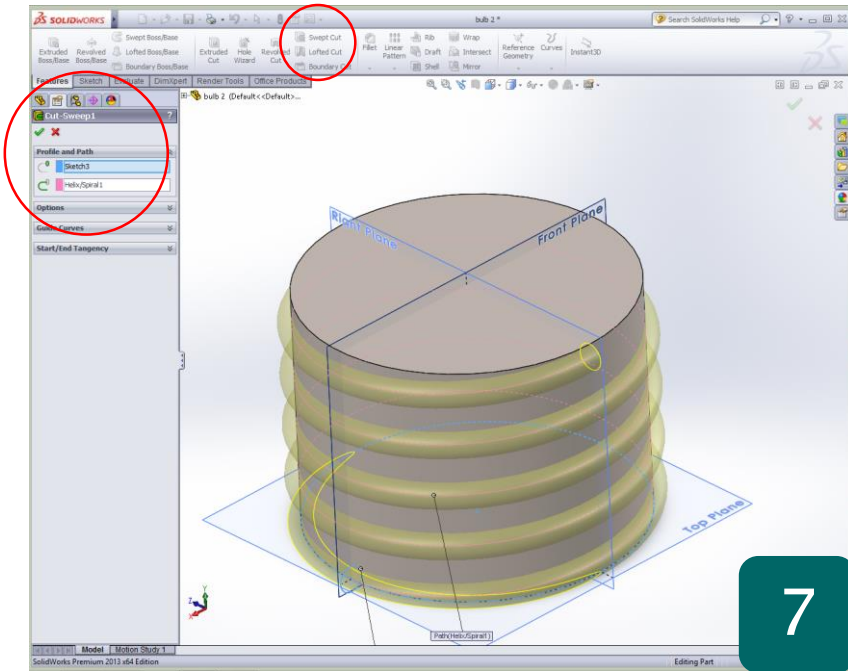

7

- Locate the point at which the helix end at the base of the cylinder
- Select the intersecting workplane and click **'sketch'**
- **CTRL + 8** to bring the view normal to
- Snap to the end of the spiral and draw a circle with a radius of 1mm
- Exit Sketch
- Select **'Swept Cut'** from the features menu
- Select the circle for the profile
- Select the helix as the feature path
- Confirm with the green tick

**Why?** – Using the swept cut feature allows for complex geometry which will follow along a range of paths. The thread could equally have been created with a Swept Boss

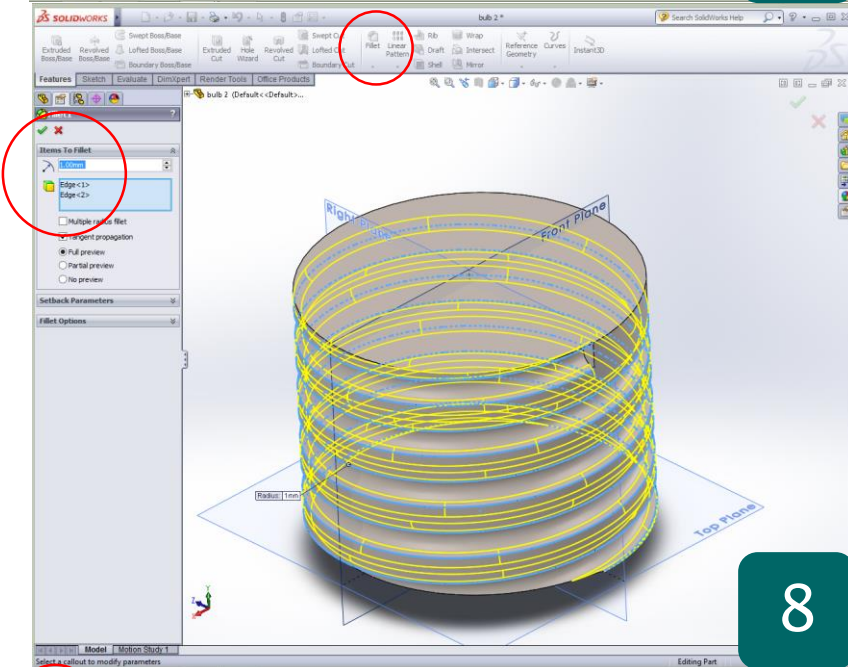

8

- Select **'Fillet'** in the **'features toolbar'**
- Select the two outside edges of the swept cut thread and set the radius to **1mm**
- Confirm with the green tick if the preview matches the screenshot

**Why?** – A light bulb has a rounded wide thread for easy changeability in the light socket. The file could have been added in the swept cut profile however it is quicker this way with regards to dimensioning

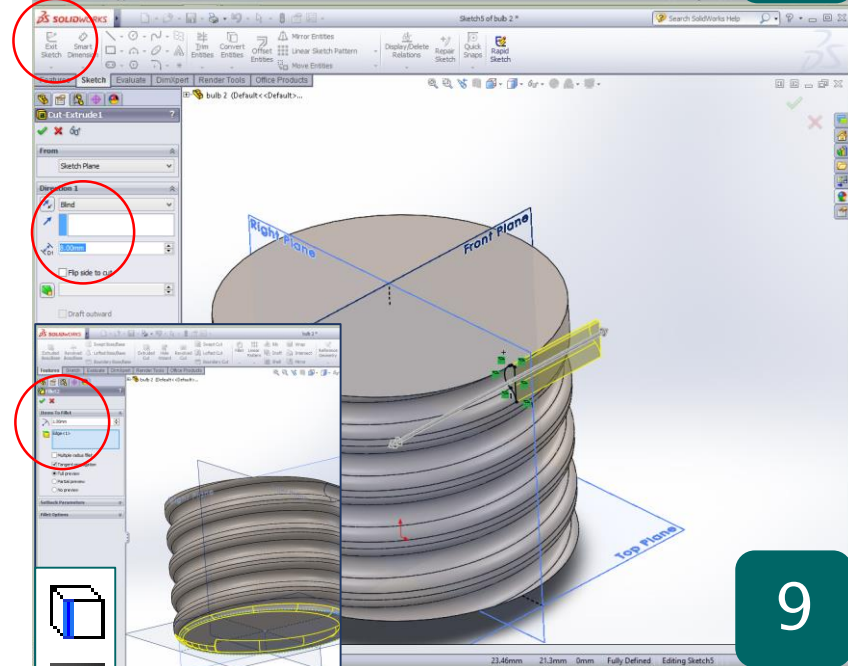

9

- Complete the thread by removing the last section to blend out the swept cut
- Although not a feature option an extruded cut can be used
- Select the inside face and click **'Sketch'**
- Click **'convert entities'** to use the geometry of the face
- **'Extruded cut'** to remove the final section of thread to any depth
- Finally fillet the base edge of the thread with a **1mm** radius

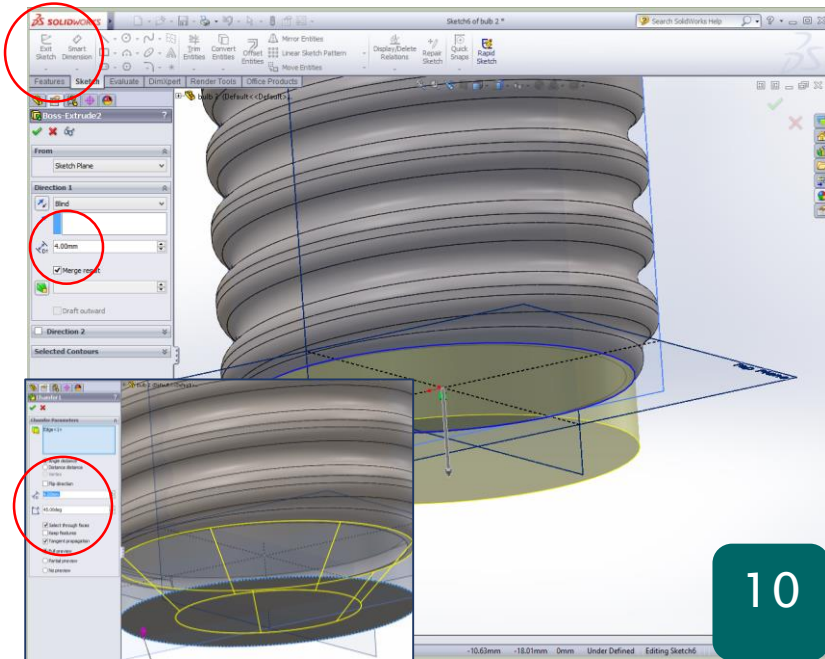

10

- Select the bottom face
- Click **'Sketch'**
- Use **CTRL + 8** to switch to normal to
- Sketch a circle using the circular edge of the thread as a snap point
- Extruded boss to **4mm**
- Confirm with the green tick
- Select **'Chamfer'** in the **'features toolbar'**
- Select the bottom edge
- Set the distance to **4mm**
- Fillet the bottom edge by **1mm**

**Why?** – The chamfered end to the bulb imitates the real world component as the electrical point of contact. This could have equally been revolved.

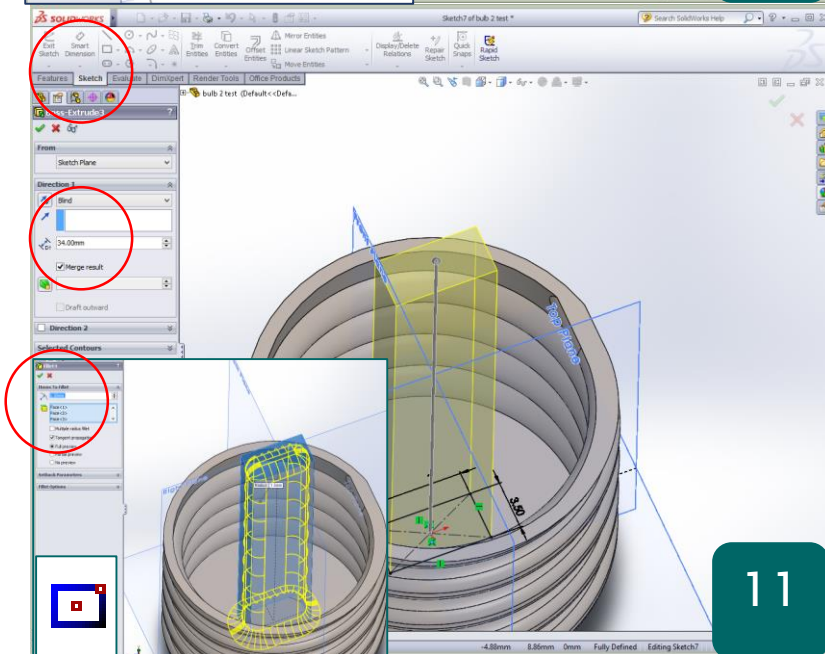

11

- Select the face at the inside base of the part
- Click **'Sketch'** in the **'Sketch toolbar'**
- Select the **'Centre Rectangle'** tool and sketch a rectangle using the centre of the part
- Smart Dimension to **3.5mm X 7mm**
- **'Extruded Boss'** to **34mm**
- **Fillet** each of the faces to **1.5mm**

**Why?** – The centre of a light bulb is generally blown glass which creates a very irregular shape. The model will represent a rough estimation of this. The **'Centre Rectangle'** is useful when looking to dimension from a central point such as this example.

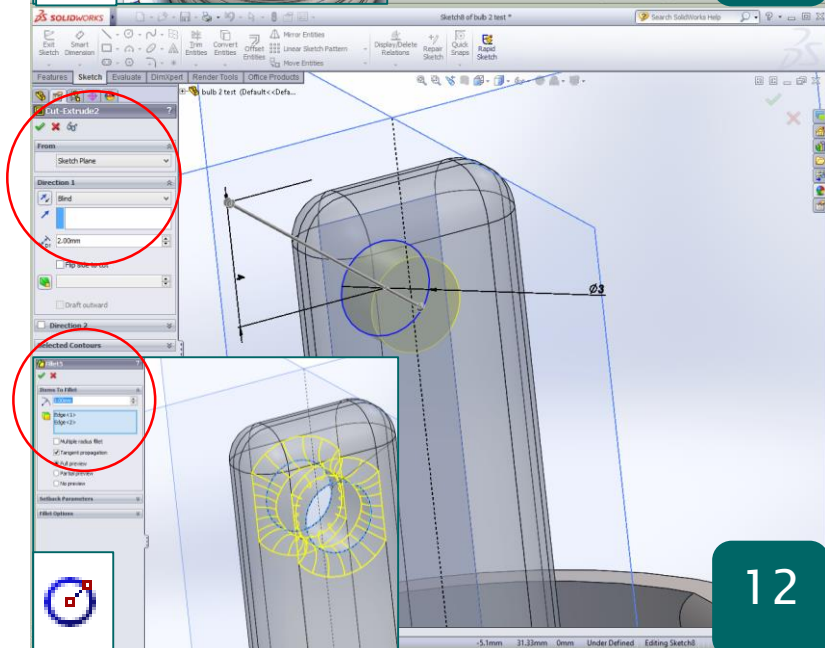

12

- Select one of the wide faces of the extrude
- Click **'Sketch'** in the Sketch toolbar
- Use the circle tool to create a rough circle
- Smart dimension its location to **4mm** down, centred and **3mm** Diameter
- **'Extruded cut'** through the extruded cuboid
- Confirm with the green tick
- **'Fillet'** the edge of the cut extrude to **1mm**
- Confirm with the green tick

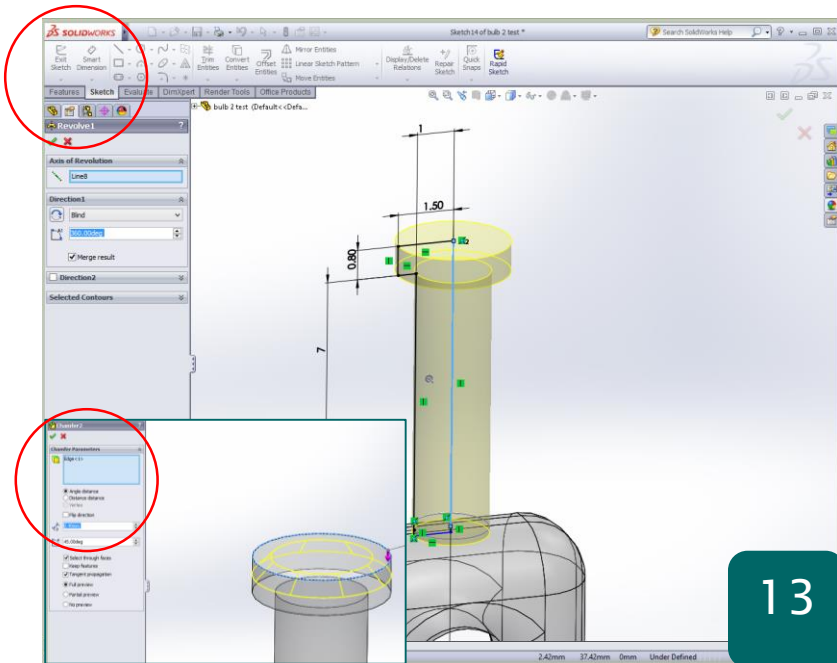

13

- Select the intersecting plane that crosses through the extruded shape
- Click **'Sketch'** and use **CTRL + 8** to bring normal
- Sketch the profile shown **7mm** up with a thickness of **1mm**
- Add a rectangle on top with a height of **0.8mm** and width of **1.5mm**
- **'Power Trim'** and cut and loose sketches and sketch a line at the centre an bottom to complete the profile
- In **'features toolbar'** click **'Revolved boss'**
- Select the inside line as the **'axis of rotation'** and confirm with the green tick
- **'Chamfer'** the top edge by **0.4mm**

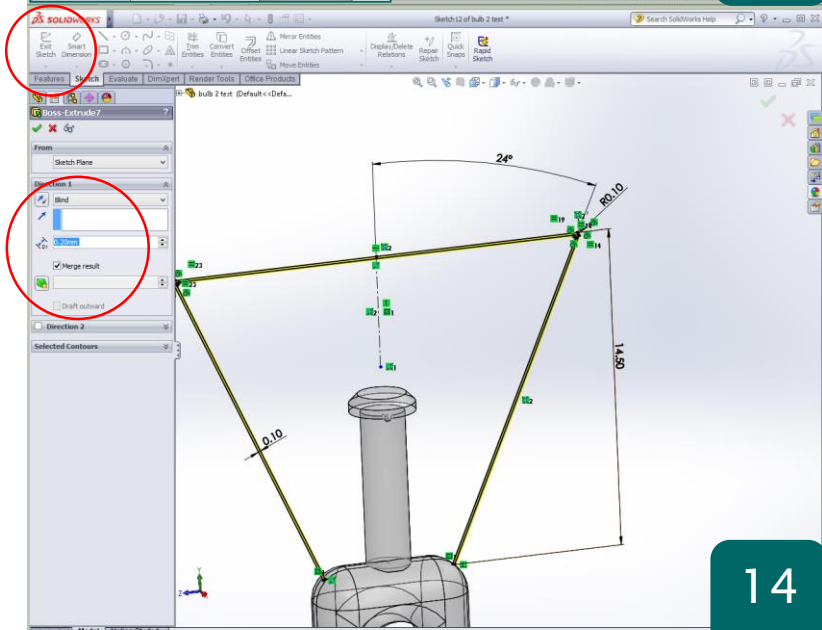

14

- Select the same intersecting work plane
- Click **Sketch** and **CTRL + 8**
- Sketch a centreline
- Copy the sketch geometry shown starting from the centreline
- **'Offset Entities'** geometry by **0.1mm**
- Use **'Sketch Fillet'** to add a **0.1mm** radius to each corner
- **'Extruded Boss'** to **0.2mm** and confirm with the green tick

**Why?** – This extrude simulates the bulb filament and can be edited to add further detail using the spiral tool to create a path to sweep along

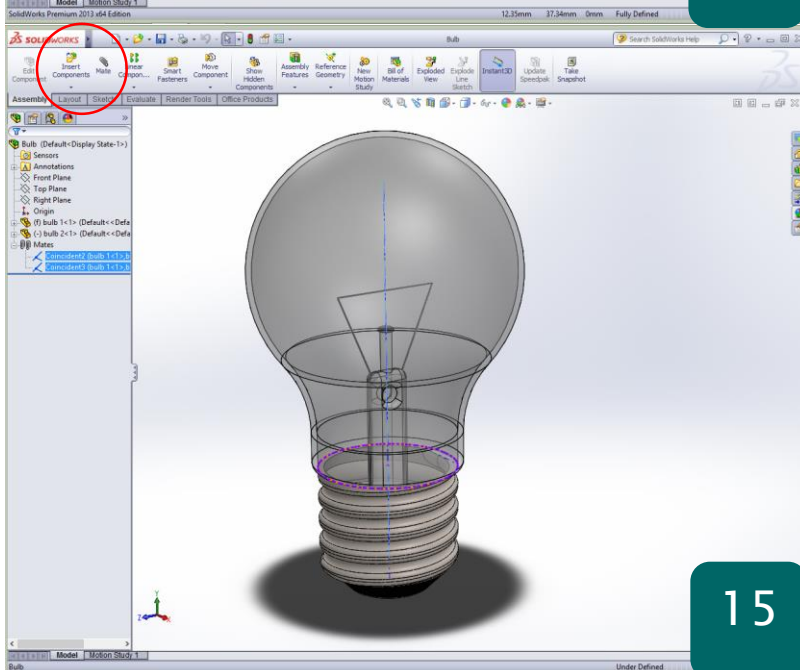

15

- **Save** the part as **'Bulb Base'**
- Open a new Assembly
- Insert the **'Bulb Base'** and **'Bulb Top'** and mate them together using their **'temporary axis'** and the end edge > top edge
- Render the bulb top as Glass and the base as a mix of stainless steel, glass and black paint
- Render ensuring **perspective** and **shadows** are switched on

**Why?** - This render should create an incredibly realistic light bulb due to the material choice and form matching the real world product closely.