

SILENTPIN™ Bracket Set

Used with all LT50, Sonesse 50 Somfy Star Head Motors

TECHNICAL DATA SHEET

The RollEase® SILENTPIN™ Bracket Set is formed from 12 gage (0.105"/2.7mm) steel with deep drawn edges for strength, silence and style. The heavy wall construction design prevents movement and deflection during operation which eliminates a source of noise in otherwise quiet motor installations.

The RollEase® SILENTPIN™ Motor Bracket Part Number: MSBM6 (Zinc/White)

Bracket is designed to accept the Somfy® star head motors. The motor snaps easily into bracket and adds extra security by increasing the "interlock" of the spring clip. This prevents the shade from working loose which is a potential problem among other brackets.

The RollEase® SILENTPIN™ Idler Bracket Part Number: MSBI6 (Zinc/White)

Bracket includes an adjustable "Idler Plate" for the SILENTPIN™ Idler which incorporates a shade leveling screw. The Idler Plate can be oriented for ceiling or wall mount installations. The SILENTPIN™ Idler shaft drops into a slot in the Idler Plate, securely retaining the pin end. The leveling screw adjusts a total of 0.375" (9.5mm) allowing for some correction during installation. With these special features, the SILENTPIN™ Idler Bracket can only be used with the SILENTPIN™ Idler. The bracket does not support any other idler.

Common Data for Both Brackets:

Mounting: Optimal performance is realized with the pairing of the SILENTPIN™ System Bracket Set and SILENTPIN™ Idler. Together they offer a secure, adjustable and silent means of mounting a motorized shade with unmatched performance. Shades can be ceiling, wall or side mounted.

Max Load: 254 lbs (115 kgs)

Qualified: The SILENTPIN™ System with the SILENTPIN™ Adapter Sets and RollEase® Tube is life tested to meet RollEase® qualification standards.

Projection: 2.5" (63mm)

Maximum Roll Diameter: 4.5" (114mm) maximum roll diameter, 3.5" diameter (90mm) to allow for drop in installation on pin end side.

Total Tube Deduction: Minimum 1.5" (0.75" Motor and Idler equal on both sides) Maximum 2.5" (0.75" motor and 1.75" Idler).

Achievable Minimum Light Gap: 0.75" minimum per side.

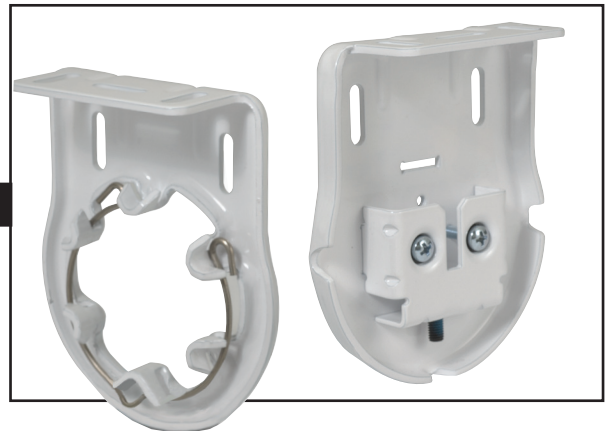

SILENTPIN™ MOTOR BRACKET - MSBM6

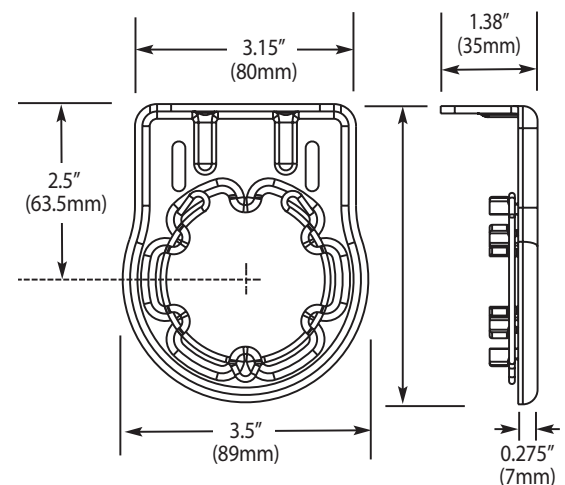

SILENTPIN™ IDLER BRACKET - MSBI6

