

ISSN: 2467-4893



# Asian Intellect

FOR ACADEMIC ORGANIZATION AND DEVELOPMENT INC.

VOLUME 1 NO. 1

MAY 2016



**Journal for  
Research,  
Education, and  
Management**

**The *Asian Intellect***  
**Journal for Research, Education, and Management**  
is an online refereed journal published by the



with  
SEC REGISTRATION NO. CN201539886  
and office address at  
BLOCK 63, LOT 20, FIESTA COMMUNITIES, SAN RAFAEL, TARLAC CITY  
EMAIL: [asianintellectorg@gmail.com](mailto:asianintellectorg@gmail.com) WEBSITE: [www.asianintellect.org](http://www.asianintellect.org)



**JOURNAL  
FOR  
RESEARCH,  
EDUCATION,  
AND  
MANAGEMENT**

**VOLUME 1, No. 1, MAY 2016**

## **Editorial Board**

**LOUELLA F. ONA, Ed.D.**  
**Editor-in-Chief**

**ENGR. MURPHY P. MOHAMMED, Ed.D.**  
**Editorial Consultant**

**JULIE LIEZEL C. FERRER, MDA**  
**Issue Editor**

**JANELA MARZEL C. FERRER**  
**Layout Editor**

**MELVIN REN ADDUN**  
**Circulation**

**JOAN MARION ADDUN**  
**Cover Design**

## **Publication Guidelines**

1. All articles must be authorized for publication by the author/s.
2. All the research papers published must have a high degree of scholarship.
- 3 All the research papers published must be approved by the editorial board .
4. All the research papers published must have undergone evaluation from our corps of referees thru double-blind referee process.
5. The articles may either be written in English or Filipino. All articles written in either languages must be accompanied by an Abstract which is written in English.
6. All contributions must be original.

# TABLE of CONTENTS

Nutritional Status of Children—Beneficiaries of Sama-samang Serbisyo Gabay sa Gawaing Ikaunlad ng Pamumuhay (SSG SAGIP) Program: Basis for Feeding Project <i>By: Juliet S. Trujillo</i>	<i>page 8</i>
Pre-Service Teaching Competence and Board Performance: How One Year Student Teaching Matters? <i>By: Dr. Orlando Z. Beñales</i>	<i>page 14</i>
Design of a Generator Booster for a Low Flow Rate Water Sytem <i>By: Gillert M. Bongcac</i>	<i>page 22</i>
Integrating E-module as a Tool in Teaching Concepts of Significance Level in Education Statistics for Graduate Students <i>By: Melanie G. Gurat</i>	<i>page 26</i>
Analysis of LET Results of the Teacher Education Graduates of Cagayan State University at Lal-lo Covering Academic Year 2010-2013 <i>By: Ferdinand Bulusan, MAEd</i>	<i>page 32</i>
Computer-Aided Language Learning in the eyes of the Indigenous People College Students <i>By: Edwin L. Nebria, Ed.D.</i>	<i>page 36</i>
Design and Simulation of a Low Ground and Low Wind Speed Energy Turbine Generator <i>By: Gillert M. Bongcac</i>	<i>page 53</i>
Design and Simulation of a Maximum Power Point Tracking Photovoltaic Source to Power Water Pumping System using MATLAB <i>By: Gillert M. Bongcac</i>	<i>page 57</i>
Design of a PiezoElectrical Cantilever Beam Electrical Conversion using Wind Energy <i>By: Gillert M. Bongcac</i>	<i>page 61</i>
Structural Model of Strategic, Collaborative and Cultural Leadership as Predictors of Quality of Work Life of School Heads <i>By: Saturnino E. Dalagan Jr.</i>	<i>page 66</i>
Influence of Professional Attributes to Secondary School Teachers' Sense of Efficacy: A Structural Model <i>By: Saturnino E. Dalagan Jr.</i>	<i>page 75</i>

# NUTRITIONAL STATUS OF CHILDREN- BENEFICIARIES OF SAMA-SAMANG SERBISYO GABAY SA GAWAING IKAUNLAD NG PAMUMUHAY (SSG SAGIP) ROGRAM: BASIS FOR FEEDING PROJECT

JULIET S. TRUJILLO  
*Faculty, College of Education*  
Carlos Hilado Memorial State College-Alijis  
Bacolod City, Negros Occidental, Region VI- Philippines

## ABSTRACT

*Nutritional and health status are powerful influence on a child's learning. The main purpose of this study is to determine the nutritional status of children-beneficiaries of Sama-Samang Serbisyo Gabay SA Gawaing Ikauunlad ng Pamumuhay (SSG SAGIP) Program as basis for supplementary hot feeding project. Descriptive research design utilizing documentary analysis was used. The 60 subjects were purposively selected in terms of their nutritional status, age, and parent's occupation. The data were gathered through the document provided by the Catabla Elementary School where in the children are presently enrolled. It was statistically treated using the frequency count and percentage as well as chi- square for the association of subject's nutritional status to their aforementioned variables. Majority of the children beneficiaries were 6 to 9 years old, and male with parents' work as laborer and fisherman with normal, wasted, severely wasted nutritional status. It is concluded that malnutrition is prevalence among children beneficiaries. In view of the above findings, supplementary hot feeding project should be proposed to help alleviate the nutritional status and to help achieve the Millennium Development Goal.*

**Keywords:** *Nutritional status, wasted, severely tasted, Supplementary Hot Feeding project*

## A. Introduction

Nutritional and health status are powerful influence on a child's learning. School age is the active growing phase of childhood. Primary school age is a dynamic period of physical growth as well as of mental development of the child (Strivastava, A et al 2012).

According to the 2007 Food and Agriculture Organization's (FAO) estimate, 923 million people in the world were chronically hungry, which was an increase of about 75 million people from the 2003-05 estimates (FAO 2008). Many of these are children, and a vast majority of them are in developing countries. These numbers suggest that the Millennium Development Goals related to hunger and malnutrition may not be met by 2015. Cited by (Lawson, 2012) the persistence of hunger, malnutrition, and micronutrient deficiencies can have long lasting effects on the health status and productivity of people and their nations. Early malnutrition can adversely affect physical, mental, and social aspects of child health, which in turn leads to underweight, stunted growth, lowered immunity, and mortality.

Research has shown that the physical effects of malnutrition as measured by indicators such as body mass index (BMI), have a significant impact on an individual's productivity and wages (Broca and Stamoulis 2003). Jomaa et al. (2011) state that childhood under-nutrition imposes significant economic

costs on individuals and nations, and that improving children's diets and nutrition can have positive effects on their academic performance and behaviors at school as well as their long-term productivity as adults. Alderman, Hoddinott, and Kinsley (2006) found that malnutrition led to delayed entry to school, less overall schooling, smaller stature, and 14% lower earnings as adults. Furthermore, poor nutrition and health among schoolchildren contributes to the inefficiency of the educational System (Del Rosso, 1999). Children who do not consume adequate amounts of key nutrients, including calcium, potassium and vitamin C may be unable to work to their full potential at school (Nabarro et al. 2012). Having a poor health is detrimental to the cognitive development of learners (Chinyoka, 2014). Thus, research has established that poor nutrition in early life can limit long term intellectual development (Lacour & Tissington 2011).

Since that nutrition in childhood is vital to everyone and to the nation, the Philippine Constitution, Article XI, Section 13 directs the state to promote and protect the physical, moral, spiritual, intellectual and social well-being of the youth, while Article XV,

Section 3.2 mandates the state to defend the right of children to assistance including proper care and nutrition (De Leon H. S & De Leon, H. M, Jr., 2011). Furthermore, in 1974, the government created the Presidential Decree 491, the Nutrition Act of the Philippines. It aims at fighting malnutrition problems in the country and defines the integration of nutrition education in the school curriculum. It declares that nutrition is a priority program to be implemented by all branches of the government (Official Gazette, 2016).

However, despite these proclamations, the Filipino children remain malnourished and undernourished. Updating the nutritional status of Filipino Children reveals that protein-energy malnutrition continued to persist in the Philippines (FNRI,2008). To help solve this problem, the Carlos Hildao Memorial State College through the Sama- samang Serbisyo Gabay SA Gawaing Ikaunlad ng Pamumuhay (SSG SAGIP) Program, takes active role in formulating strong initiative to strengthen its involvement in community development programs reflective in its mission, vision and goals. Through its adopted community barangay, the feeding program will be introduced as a social safety net for achieving one the Millennium Development Goals. This program targets pupil- beneficiaries who skip breakfast, experience food insecure and reside in areas with high concentrations of families from low socioeconomic status, as well as with poor attendance in school. According to Elle, P. (n.d.), eating breakfast can improve cognitive performance of the students, especially in younger children. Breakfast provides children with energy and essential nutrients, including iron, calcium and vitamins B and C, which are necessary for growth, development and good health (Australian Red Cross, n.d). Furthermore, eating breakfast has positive effect to students' overall dietary health and academic performance (Gleason, P., & Sutor,C. ,2001). There was additional evidence that habitual breakfast (frequency and quality) and School Breakfast Program have a positive effect on children's academic performance with clearest effects on mathematic and arithmetic grades in undernourished children (Adolphus, 2013).

It is in this context that this study was undertaken. After determining the nutritional status of children- beneficiaries, the feeding project will be proposed and implemented to help increase the attention and concentration of pupils producing gains in cognitive function and learning. It also motivates parents to enroll their children in school and have them attend regularly. Lastly, it also helps to address specific micronutrient deficiencies in school-age children.

## **B. Statement of the Problem**

The main purpose of this study is to determine the nutritional status of children-beneficiaries of SSG SAGIP Program as basis for supplementary hot breakfast feeding project.

Specifically, the following questions were raised in relation to the aforementioned problem:

1. What is the profile of children-beneficiaries in terms of age, sex, and occupation of parents?
2. What is the nutritional status of children- beneficiaries when grouped according to the categories of:
  - a. severely wasted;
  - b. wasted; and
  - c. normal?
3. Is the nutritional status of children-beneficiaries dependent on their age, sex and occupation of their parents?
4. Based on findings, what feeding program should be proposed?

## **C. Research Methodology**

This study used the descriptive research design utilizing documentary analysis method in order to attain its objectives. According to Johnson & Christensen (2012), the primary purpose of descriptive research is to provide an accurate description or picture of the status or characteristics of a situation or phenomenon. On the other hand, Scott (2006) explained that the use of documentary analysis is to support the view point and a process of conceptualizing, using and assessing documents. Since, the researcher analyzed the documents on the results of nutritional status of children beneficiaries; the design was the most suited framework to use.

## **Subjects of the Study**

The subjects of the study were 60 selected enrollees of Catabla Elementary School. They were purposively selected as children-beneficiaries who came from primary grade and with normal, wasted, severely wasted nutritional status.

## **Source of Data**

Data were gathered through the document provided by the Catabla Elementary School where in the children are presently enrolled. The document provided the data on the grade level, age, sex, parents' occupation and their nutritional status as of July.

It contains the name of the children- beneficiaries, their profile and nutritional status such as normal, wasted, severely wasted.

**D. Results and Discussion**

Data were gathered in connection with the objectives set forth in this study. These data were analyzed and interpreted accordingly with the use of appropriate statistical tools.

1. Table 1 presents the profile of children- beneficiaries in terms of their age, sex and parent’s occupation. It that majority children beneficiaries were 6 to 9 years old, and male with parents’ work as laborer and fisherman. Findings in several studies conducted by FNRI/ DOST (DOH, 1998), and that of the DECS- SHNC (1992) study on nutritional status of Filipino elementary school children 7-14 years old revealed that among 6- 10 year old school children, boys were more at risk than girls.

Table 1. Profile of Children- beneficiaries of SSG SAGIP Program

Variables		n	%
Sex	Female	25	42
	Male	35	58
	Total	60	100
Age	6 to 7 years old	33	55
	8 to 9 years old	16	27
	10 to 11 years old	7	12
	12 to 13 years old	2	3
	14 years old and above	2	3
Parent’s occupation	Total	60	100
	Laborer	24	40
	Fishermen	27	45
	Construction worker	4	7
	Carpenter	2	3
	Fish vendor	2	3
Total	None	1	2
Total		60	100

2. Table 1 presents the nutritional status of children- beneficiaries when they are group according to sex. The data indicated that from the 37 normal subjects, 18 or 30 percent were female, 19 or 32 percent were males; wasted subjects were 7 or 12 percent female and 14 or 23 percent were males; and in severely wasted composed only the 2 or 3 percent of male. The result shows that the prevalence of under nutrition was higher among male than female beneficiaries. The result was similar to the evidence suggests that boys are more likely to be stunted and underweight than girls, and in some countries, more likely to be wasted than girls (Strivastava, A et al 2012). The same result could be found in the study of Triño (2002), among beneficiaries, males were more susceptible to stunting than their female counterparts.

Table 1. The Nutritional Status of children- beneficiaries when grouped according to sex

Figure 1. The Nutritional Status of children- beneficiaries when grouped according to sex

Category	Normal		Wasted		Severely Wasted		Total	
	F	%	f	%	f	%	f	%
Female	18	30	7	12	0	0	25	42
Male	19	32	14	23	2	3	35	58
Total	37	62	21	35	2	3	60	100

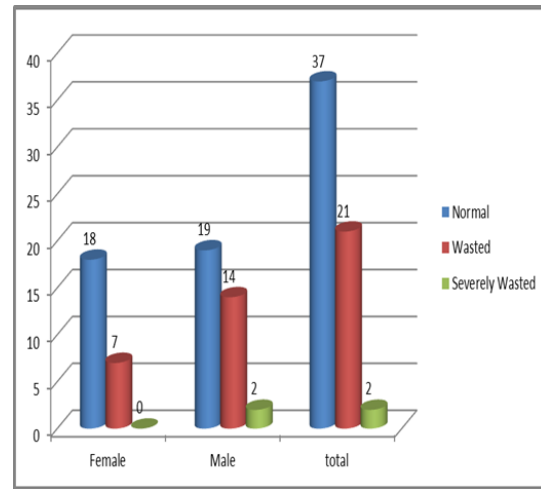

3. Table 2 presents the data on the nutritional status of children beneficiaries when they were grouped according to age. It shows that the wasted and severely wasted groups were characterized by a sharp increase from the age bracket of 6-7 with 11 or 18 percent and 1 or 2 percent respectively. This sharply decreases from the age bracket of 12 years old and above. The result reveals that among the subjects, the ages most heavily affected with under nutrition was age bracket 6 to 7 years old at 33 or 55 percent, followed by 8 to 9 years old at 16 or 27 percent, 10 to 11 years old with 7 or 12 percent, and ages 12 years old and above had the lowest number of percentage. Recently, the findings of FNRI/DOST indicated that children 5 to 10 years old were prevalence to underweight compared to the 0-5.0 age group at 29.1%, though this is already an improvement from the 32% prevalence in 2011. Wasting/ thinness is also higher than in the younger age group at 8.6%; this is unchanged from the 8.5% of 2011 (FNRI/DOST, n.d).



Table 2. The Nutritional Status of children-beneficiaries when grouped according to Age

Category	Normal		Wasted		Severely Wasted		Total	
	f	%	f	%	f	%	f	%
6 to 7 years old	21	35	11	18	1	2	33	55
8 to 9 years old	13	22	3	5	0	0	16	27
10 to 11 years old	2	3	5	8	0	0	7	12
12 to 13 years old	1	2	1	2	0	0	2	3
14 years old and above	0	0	1	2	1	2	2	3
Total	37	62	21	35	2	3	60	100

Figure 2. The Nutritional Status of children beneficiaries according to age

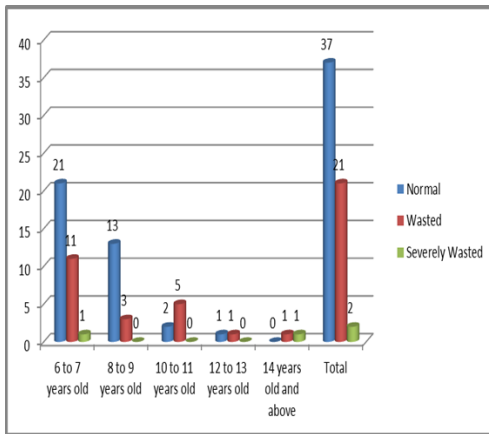

4. Table 4 presents the Nutritional Status of children-beneficiaries when grouped according to parent's occupation. It shows that 27 or 45 percent of the subjects' parent's occupation is fisherman, followed by 24 or 40 percent of their parent's occupation is laborer, 4 or 7 percent of the subjects' parents is construction worker, 2 or 3 percent of their parent's occupation is carpenter and fish vendor. A scrutiny of the data showed that 11 or 18 percent and 7 or 12 percent of the beneficiaries belong to the wasted group was children of the laborers and fishermen; 1 or 2 percent of the subjects' parents occupation is construction worker, carpenter, and fish vendor. It is shown also that 1 or 2 percent of those belonging to the severely wasted subjects have the parent's occupation as laborer or the other 1 or 2 percent has parents that do not have work. The results implies that children-beneficiaries of SSG SAGIP Feeding Project are children of fishermen and laborers with low-income. The findings of Maximo (1975), reveals that most of the children who came from low-income families and earned their livelihood from manual labor, hence malnourishment was common among them. This was true in study of Fuchs C, Sultana T, Ahmed T, Hossain MI (2014) entitled "Factors Associated with Acute Malnutrition among Children Admitted to a Diarrhea Treatment Facility in Bangladesh". According to them father's occupational status turns out to be a more accurate indicator for malnutrition rather than household in-

come as found in their study; and this finding is just similar to few studies in past- who found that children of fathers who were day laborers were -3 times more likely to be severely underweight and the fathers of most (84%) of the wasted children were either rickshaw pullers or day laborers (Saito K, Korzenik JR, Jekel JF, Bhattacharji S., 1997).

Table 4 The Nutritional Status of children-beneficiaries when grouped according to parent's occupation

Category	Normal		Wasted		Severely Wasted	
	f	%	f	%	F	%
Laborer	12	20	11	18	1	2
Fisherman	20	33	7	12	0	0
Construction worker	3	5	1	2	0	0
Carpenter	1	2	1	2	0	0
Fish vendor	1	2	1	2	0	0
None	0	0	0	0	1	2
Total	37	62	21	35	2	3

Figure 3. The Nutritional Status of children-beneficiaries according to parent's occupation

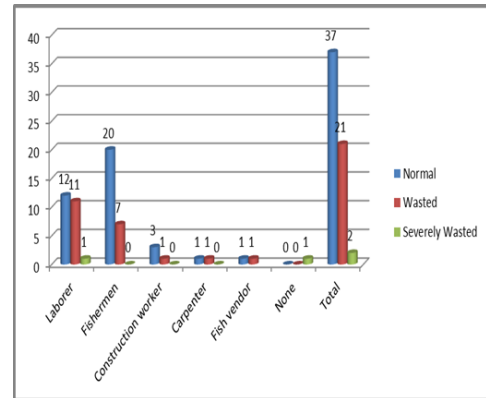

5. Data on Table 5 presents the association of nutritional status to children-beneficiaries characteristics in terms of sex, age, parent's occupation. It shows that the variables of sex gave a tabular value of 1.763 at degree of freedom of 2. The computed chi-square value was .414, which means that the nutritional status is not associated with the sex. The same finding was found in the parent's occupation with the tabular value of 16.553 at degree of freedom of 12. The computed chi-square value is .167 is greater than 0.05 level of significance which shows that this variable is independent or not associated with the children nutritional status. However, the variable of age gave a tabular value of 48.663 at the degree of freedom of 16. The computed chi-square of .000 is lesser than the

nutritional status of children is associated with their age.

Table 5 The Independence of Nutritional Status of Children-beneficiaries from their selected Variables

Variables	Value	df	Asymp. Sig. (2-sided)
Sex	1.763 <sup>a</sup>	2	.414
Age	48.663 <sup>a</sup>	16	.000
Parent's Occupation	16.553 <sup>a</sup>	12	.167

6. Supplementary Hot Feeding Project will be proposed to alleviate the nutritional status of the children beneficiaries. The project entitled, "Mainit na Almusal: Alay sa Mag-aaral will be given three times a week to children-beneficiaries by teachers with cooperation of parents and students' extentionist. This project aims to create awareness on the importance of eating breakfast; provide nutritionally adequate breakfast to the pupils and to utilize the feeding as an avenue to develop health and nutrition values and behavior. The sample one-week menus are arroz caldo rolyale, banana blossom medley, and champorado with mungbean. These sample recipes were selected with consideration on low cost, easy handling and preparation, and nutritional adequacy.

### I. Conclusions and Recommendations

On the basis of the findings, the following conclusions were drawn:

1. Majority of the beneficiaries ages 6 to 10 years old are male and children of laborers, fishermen, and construction workers.
2. Malnutrition is still prevalence among children-beneficiaries.
3. Age is associated with the nutritional status of the children.

Based on findings, supplementary hot feeding breakfast will be introduced.

### Recommendations

Based on findings and conclusions, the following recommendations are hereby advised:

1. The program planners, school administrators, teachers and other school personnel with knowledge regarding the importance of supplementary program and the delivery of its services, should strengthen the program for the continuous improvements of the physical health of the school children.
2. Intensive participation of both the adopted school and the community for home gardening planted with vegetables needed for the supplementary feeding of children, dissemination of information to

the community regarding home activities for children and organizing parents into association.

3. School administrators, teachers and parents must use these research findings to be included in policy making and program development for the school children.

### References

- Alderman, H., Hoddinot, J and Kinsey, B., (2006). Long Term Consequences of Early Childhood Malnutrition, Oxford Economic Papers. Volume 58. Issue 3
- Adolphus, k. L. et al (August 2013). The effects of breakfast on behavior and academic performance in children and adolescents. Retrieved from <http://www.ncbi.nlm.nih.gov/pmc/articles/PMC3737458/>
- Australian Red Cross (n.d). Why is breakfast important for students? retrieved from [http://www.redcross.org.au/files/Fact\\_sheet\\_4\\_\(2\).pdf](http://www.redcross.org.au/files/Fact_sheet_4_(2).pdf), February 22, 2016.
- Broca S., Stamoulis K., (2003). Micro- and Macro evidence on the Impact of Undernourishment, Nutrition Intake and Economic Growth, and Social Development, Food and Agriculture Organization of the United States
- Christensen, & Johnson (2012). Educational Research (Quantitative, Qualitative, and Mixed Approaches) Fourth Edition. United States of America: SAGE Publications, Inc.
- Chinyoka, K. (2014). Impact of Poor Nutrition on the Academic Performance. International Journal of Learning & Development, p12.
- De Leon, Hector & De Leon, Hector M. Jr (2011). Textbook on the Philippine Constitution. Rex Printing Company, Inc. : Quezon City, Philippines.
- Del Rosso, J. M. (June 1999). [portal.unesco.org/Ipinanumbalik\\_mula\\_sa\\_kay\\_www.google.com:http://portal.unesco.org/education/en/files/37434/11029402593School-feeding-p5programs.pdf/School-feeding-programs.pdf](portal.unesco.org/Ipinanumbalik_mula_sa_kay_www.google.com:http://portal.unesco.org/education/en/files/37434/11029402593School-feeding-p5programs.pdf/School-feeding-programs.pdf)
- Elle, Puala (n.d), Benefits of Eating Breakfast for Students retrieved from <http://healthyeating.sfgate.com/benefits-eating-breakfast-students-7697.html>, February 22, 2016.
- Gleason, P., & Suitor, C. (2001). Children's diets in the mid-1990s: Dietary intake and its relationship with school meal participation. Nutrition Assistance Program Report Series, No. CN-01-CD1. Alexandria, VA: USDA, FNS, Office of Analysis, Nutrition and Evaluation. p 61.

- Lawson, T. M. (2012). Impact of School Feeding Programs on Educational, Nutritional, and Agricultural Development Goals: A Systematic Review of Literature. Retrieved August 10, 2015, from google.com.
- Lacour, M. & Tissington, LD. 2011. Educational research and reviews. *Academic Journal*, 7 (9): 522-527.
- Food and Agricultural Organization (2008) of the United Nations, *The State of Food Insecurity in the World*. Rome
- Jomaa L.H., McDonnell E., and Probart C. (2011), *School Feeding Programs in Developing Countries: Impacts on Children's Health and Educational Outcomes*. *Nutrition Review*.
- Fuchs C, Sultana T, Ahmed T, Hossain MI. (2014). "Factors Associated with Acute Malnutrition among Children Admitted to a Diarrhoea Treatment Facility in Bangladesh," *International Journal of Pediatrics*, vol. 2014, Article ID 267806, 5 pages.
- Maximo, Olympia V. (1975). "Some Problems of the Nutrition Program of the Elementary Schools of Cavite City, District II, , Master Thesis: Ortanez University Manila. Published by Child and Youth Research Center, Manila, Philippines.
- Nabarro, D., Menon, P., Ruel, M. & Yosef, S. 2012. *Scaling Up Nutrition: A global movement to accelerate progress in reducing maternal and child under-nutrition*. Brief 9. In: J. Linn. (ed.).
- Official Gazette (2016). Presidential Decree No. 491, s. 1974. Retrieved from <http://www.gov.ph/1974/06/25/presidential-decree-no-491-s-1974>
- Strivastava, A. et al (2012). Nutritional Status of School -Age Children- A Scenario of Urban Slums in India. *Archives of Public Health*, 11.
- Saito K, Korzenik JR, Jekel JF, Bhattacharji S. A case-control study of maternal knowledge of malnutrition and health-care-seeking attitudes in rural South India. *Yale J Biol Med*. 1997 Mar-Apr; 70(2):149-60.
- Triño, Marcelita D. (2002). *Supplementary Hot Breakfast: Its Impact on the Nutritional Status and Academic Performance of Its Pupil-Beneficiaries*, A Unpublished Dissertation Presented to the Faculty of the Graduate School, PROJECT FREE, University of St. La Salle, Bacolod City

## PRE-SERVICE TEACHING COMPETENCE AND BOARD PERFORMANCE: HOW ONE YEAR STUDENT TEACHING MATTERS?

**Dr. Orlando Z. Beñales**

Carlos Hilado Memorial State College  
Talisay City, Negros Occidental  
E-Mail Address: *OZB\_Sheerland@yahoo.com*  
Phone: 09398869404

### ABSTRACT

*The thrust of teacher education is to develop the teaching efficacy of the Pre-Service Teachers (PSTs) to ensure their passing performance in the Licensure Examinations for Teachers (LET) and enhance their entry into professional teaching. Towards this thrust, how One Year Student Teaching (OYST) matters? This descriptive-correlational research explored the teaching competence of the sampled PSTs in OYST during the Academic Year 2012-2013, and looked into their performance in the LET in 2013 and 2014. Completed in October 2015, the PSTs and their Supervising Teachers (STs) assessed the teaching competence in the professional, technical, and personal-social areas using the 74-item validated Student Teaching Performance Evaluation Instrument. Means and standard deviations were used for descriptive analyses. For inferential analyses set at .05 level of significance, t-test for independent samples, t-test for correlated samples, Pearson's r and ANOVA including Tukey test as post hoc test were used. Computer-processed data showed that generally, the PSTs saw themselves to be possessing very high level of teaching competence in both semesters of training, although their STs rated it to a high level which is one level lower than their self-rating. The immersion of the PSTs to another semester of student teaching all the more improved their teaching competence. The programs they enrolled in, their specializations, and the student teaching periods are factors in the development of their teaching competence. Whether they are BEd or BSEd PSTs did not affect their performance in the LET but their specializations did. Generally, they were average performers in the three components of the LET, although the TLE, MAPEH, and General Education groups fell below the passing mark. The teaching competence they demonstrated in OYST significantly influenced their performance in the LET.*

Keywords: *one year student teaching, pre-service teaching competence, board performance*

### INTRODUCTION

Teacher Education Institutions (TEIs) are tasked to produce teaching practitioners through quality Teacher Education Programs (TEPs). One mark of quality is gauged in the graduates who possess necessary teaching competence and passing performance in the LET to be allowed entry into the teaching profession. The rigid entry requirements underscore the fact that professional teaching is demanding as teaching practitioners should clearly understand what should be done to bring about the most desirable learning in the students and be highly proficient in the skills necessary to carry out these tasks ([www.journals.savap.org.pk](http://www.journals.savap.org.pk)).

The Commission in Higher Education (CHED) emphasizes that all efforts to improve the quality of education are dependent on the service of teachers who are properly prepared to undertake the various important roles and functions of teachers. As such, it is of utmost importance that the highest standards are set in defining the objectives, components, and processes of the pre-service teacher education curriculum (CMO No. 30, s. 2004). It is necessary that the PSTs get the

right training and be equipped with the needed competence before they join the teaching force (Dinagsao, 2013). In the actual teaching field, teachers who have had more preparation for teaching are more confident and successful with students than those who have little (Hammond, 2000).

With the enactment of Republic Act 7836, the "Philippine Teachers Professionalization Act of 1994" all the more sets a rigid screening mechanism for entrants to the teaching profession to ensure that only those who passed the LET, with valid certificate of registration and valid professional license be allowed to practice their teaching profession (Article IV, Section 27). The LET, administered by the Philippine Regulatory Commission (PRC), serves as a gauge of the effectiveness of the delivery of the teacher education curriculum completed by the teacher applicants and a quality assurance to those who enter the teaching profession. It is designed to protect the public by

ensuring that graduates are allowed to practice the teaching profession after they have met the requirements of becoming teachers. Performance in the LET is one major indicator of quality and excellence (Gerundio & Balagtas, 2014).

Many teacher educators continue to look for effective ways to better prepare future teachers for the students they will encounter in the classroom. A continuing concern for teacher educators is how to improve the effectiveness of student teaching and demonstrate the benefits of the program to prospective teachers (Buitink, 2009).

Amid all efforts to improve the TEP is the question as to whether the PSTs are ready for the job. In an effort to prepare the PSTs to be more responsive to the demands of the teaching profession, the College as research venue, has embraced program accreditation and has undergone continuous curricular development. Among others, the lengthening of student teaching to two semesters for both the BEEd and BEEd TEPs is a milestone in this continuous improvement. OYST took initial implementation during Academic Year 2009-2010. In March 2013, the pioneer graduates of this program earned their degrees and majority of them took the LET in September 2013 and some in January 2014. How teaching competence and LET performance interplay in the picture can provide empirical data to demonstrate the contribution of the OYST to the development of teaching competence among PSTs, to validate better prospect for passing the LET, and for curricular development in teacher education.

#### *Statement of the Problems*

This study sought answers to the following questions:

1. What is the level of teaching competence of the Pre-Service Teachers (PSTs) in One Year Student Teaching (OYST) as assessed by them when they are taken as entire group and when classified as to programs, training periods and specializations?

2. What is the level of teaching competence of the PSTs in OYST as assessed by the Supervising Teachers (STs) when the PSTs are taken as entire group and when classified as to programs, training periods and specializations?

3. What is the level of their performance in the three curricular components of the LET, namely, General Education, Professional Education, and Major Courses when they are taken as entire group and when classified as to programs and specializations?

4. How does the teaching competence of the PSTs in OYST differ as assessed by them when they are classified as to program, training periods and specializations?

5. How does the teaching competence of the PSTs in OYST differ as assessed by the STs when the PSTs are classified as to programs, training periods and specializations?

6. How does the performance in the LET differ when the graduates are classified as to programs and specializations?

7. How does the teaching competence of the PSTs in OYST as assessed by the STs relate with their performance in the LET?

#### *Theoretical / Conceptual Framework*

All academic thrusts in teacher training underscore the fact that the teachers are the main pillar of the educational system (Kant, 2011). As it is, the development of teaching skills or teaching competence of the PSTs is directed towards developing their self-confidence and self-efficacy. Gibbs (2015) explains that the capacities of teachers to survive, to demonstrate resilience, persistence, and innovativeness are governed primarily by their beliefs about their capacity – that is their self-efficacy as teachers. Giallo and Little (2003) point out that the teachers who are the most effective classroom managers are the most confident in their abilities. Preparedness and classroom experiences are factors that are involved in the development and maintenance of teacher self-efficacy.

A better understanding of the development of self-confidence and its influence on behavior and performance can be gleaned from the Theory of Self-Efficacy of Bandura (1986). Self-efficacy, in this perspective, is conceptualized by Bandura as a person's judgment of his/her ability to execute successfully a behavior required to produce certain outcomes. Giallo and Little (2003) elucidate that behavior is influenced not only by the belief that a particular action will lead to desirable outcomes, but also by the belief that one has the ability to perform the action. Bandura (1986) speaks of this ability to persist in difficult situations – a belief that determines how a person thinks, behave, and feel.

The teacher's sense of efficacy is an important variable in teacher development and how teachers teach (Moran, 1998). How to improve effectiveness of student teaching as component of pre-

service education such that it prepares prospective teachers with necessary ability, confidence or self-efficacy becomes a continuing concern for teacher educators (Buitink, 2009). Within the pre-service teacher education program, the prospective teachers are immersed to various trainings that culminate in student teaching, which is considered to be the most significant component of teacher preparation programs (Plourde, 2002). Its primary goal is to provide the opportunity for acquisition and demonstration of instructional competence for beginning professional educators ([www.utpa.edu/colleges/coe](http://www.utpa.edu/colleges/coe)).

Teaching competence can be measured through mastery of content knowledge and pedagogical skills. A competent teacher should have the professional artistry to induce learning among students. Cognitive skills like critical thinking, creative thinking, and problem solving are required of the teacher (Dayagbil & others, 2012). In this study, the teaching competence of the PSTs is measured in the professional, technical, and personal-social competence areas and is linked with their performance in the LET. The LET is composed of three components namely, general education, professional education, and major courses for the Secondary TEP. The Elementary TEP graduates take the general education and professional education courses only. An examinee has to score not lower than 50% in any areas in order to pass the examination (<http://education-teaching-careers.knoji.com>). The schematic diagram below illustrates the conceptual framework of the study:

## METHODOLOGY

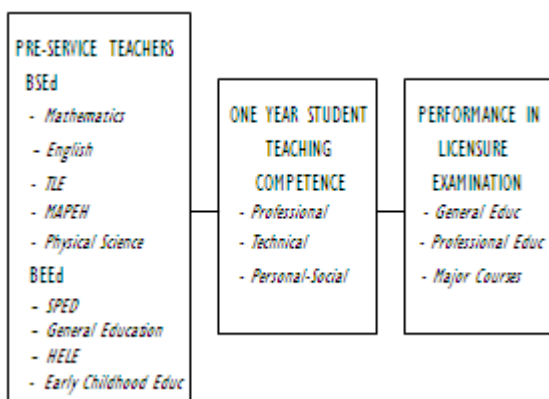

### Method of Research Used

This study used a descriptive type of research as it focused on the teaching competence demonstrated during the OYST as assessed by the PSTs themselves and on documentary analyses on their performance in OYST as gauged by the grades submitted by the STs at the end of the training, and on their scores obtained in the LET.

### Subjects / Respondents of the Study

The subject-respondents were the 171 PSTs enrolled in the Level III-AACCUP accredited BSEd and BEEd programs of Carlos Hilado Memorial State College (CHMSC) in Talisay City, Negros Occidental, Philippines. The sample represented the total population of 299 PSTs during the Academic Year 2012-2013. The sample size was computed using the formula of Pagoso (1992). Using stratified random sampling technique, the representative samples from the various specializations of the BSEd and BEEd programs were identified for this research (Table 1). Their respective STs were the sources of data in their capacity as evaluators of student teaching performance. The biggest number of subject-respondents came from the BEED General Education majors (n=67) and the lowest number was represented by the BSEd MAPEH (n=22).

### Research Instrument and Sources of Data

The Student Teaching Performance Evaluation Instrument which has been used by the College since 2002 in the evaluation of teaching performance of the PSTs was used in this study. As an official doc-

**Table 1**  
*Distribution of PSTs as to Programs & Specializations*

Academic Programs	N	%	n
Overall	299	100	171
BSEd Program			
BSEd - Mathematics	20	6.43	11
BSEd - English	36	12.28	21
BSEd - TLE	31	10.53	18
BSEd - MAPEH	22	7.60	13
BSEd - Physical Sci	27	8.77	15
BEEd Program			
BEED - SpEd	28	9.36	16
BEED - Gen Ed	67	22.22	38
BEED - HELE	36	12.28	21
BEED - ECE	32	10.53	18

ument, this 74-itemed instrument covers three major teaching competence areas, namely, professional, technical, and personal-social aspects. The validity and reliability of the research instrument were established prior to its initial year of utilization in the Student Teaching Program of the College of Education. To ensure, however, of its reliability for the conduct of the present research, the instrument was reliability-tested

among the thirty BSEd and BEEd students who were exposed to teaching demonstrations. The reliability index of 0.97 resulting from the use of Cronbach alpha indicated that the instrument had the capacity to elicit stable data. On the other hand, the performance in the board examination was sourced from the scores obtained in the LET in September 2013 and January 2014 which were requested by the College from the PRC in 2015.

*Procedures for Data Analysis*

In order to provide answers to the problems of the study, means and standard deviations were used as descriptive statistics. For inferential analyses set at .05 level of significance, t-test for independent samples, t-test for correlated samples, Analysis of Variance (ANOVA), and Pearson’s Product Moment Coefficient of Correlation (PPM) were used. All data were computer-processed.

**RESULTS AND DISCUSSIONS**

*Level of Teaching Competence*

Generally, as assessed by themselves, the PSTs believed that they possess a very high level of teaching competence ( $M = 4.32$ ) in OYST (Table 2). The same very high level of teaching competence was also obtained during the first and second semesters of training ( $Ms = 4.26$  and  $4.37$ , respectively).

When grouped as to program, the BEEd group exhibited a very high level of teaching competence both during the first and second semesters with means

**Table 2**  
*Self-Assessed Teaching Competence of PSTs*

Variable Groupings	Student Teaching Competence						Overall		
	First Semester			Second Semester			M	SD	Desc
<b>Overall</b>	4.26	0.45	VH	4.37	0.45	VH	4.32	0.36	VH
<b>Program</b>									
BSEd	4.08	0.48	H	4.30	0.40	VH	4.19	0.39	H
BEEd	4.41	0.37	VH	4.43	0.49	VH	4.42	0.31	VH
<b>Specializations</b>									
Math	4.20	0.36	H	4.38	0.39	VH	4.29	0.32	VH
English	4.09	0.47	H	4.39	0.27	VH	4.24	0.33	VH
TLE	4.14	0.42	H	4.18	0.42	H	4.16	0.36	H
MAPEH	3.80	0.59	H	4.15	0.51	H	3.98	0.53	H
Phy Sci	4.17	0.47	H	4.40	0.41	VH	4.29	0.36	VH
SpEd	4.29	0.31	VH	4.44	0.34	VH	4.37	0.31	VH
Gen Ed	4.45	0.36	VH	4.43	0.62	VH	4.44	0.36	VH
HELE	4.44	0.39	VH	4.44	0.45	VH	4.44	0.28	VH
ECE	4.41	0.40	VH	4.42	0.32	VH	4.41	0.25	VH

scores of 4.41 and 4.43, respectively. Their BSEd counterpart obtained a high level ( $M = 4.08$ ) of teaching competence during the first semester. However, during the second semester, their teaching competence raised to a very high level ( $M = 4.30$ ).

When classified as to specializations, the BEEd group with majors in General Education, HELE, ECE, and SPED exhibited a very high level of teaching competence both during their first and second semesters, with mean scores ranging from 4.29 to 4.45.

All majors under the BSEd programs obtained a high level of teaching competence during the first phase of student teaching with mean scores ranging from 4.09 to 4.20. Except for TLE and MAPEH majors who maintained a high level of teaching competence, the English, Physical Science, and Mathematics groups raised their level of teaching competence to a very high level during the second phase of immersion to actual teaching with mean scores ranging from 4.15 to 4.40.

The SDs which ranged from 0.25 to 0.53 indicated a narrow dispersion of the scores indicating that the PSTs were homogeneous in their responses when asked about their level of teaching competence at the end of every semester of student teaching.

The findings were indicative that PSTs believed that after the two-semester exposure to student teaching, they acquired a favorable level of teaching skills and attributes needed for teaching. Their assessment of their teaching competence to the very high level showed their confidence to meet the challenges of the teaching profession. The teaching competence of the MAPEH and TLE majors in the BSEd program which retained the high level even after the second semester student teaching is a valuable input in the analysis of the effectiveness of the activities they were exposed to during their pre-service education.

*Level of Teaching Competence as Assessed by the STs*

Generally, as assessed by the STs (Table 3), the PSTs obtained a high level of teaching competence ( $M = 91.35$ ). High levels of teaching competence were also earned during the first and second semesters of training ( $Ms = 90.90$  and  $91.81$ , respectively).

**Table 3**  
*Teaching Competence of PSTs as Assessed by STs*

Variable Groupings	Student Teaching Competence						Overall		
	First Semester			Second Semester			M	SD	Desc
<b>Overall</b>	90.90	2.85	H	91.81	2.44	H	91.35	2.65	H
<b>Program</b>									
BSEd	89.87	3.53	H	90.97	3.09	H	90.42	3.10	H
BEEd	91.77	1.70	H	92.51	1.40	H	92.13	1.30	H
<b>Specializations</b>									
Math	92.00	3.49	H	92.27	1.79	H	92.14	2.22	H
English	91.38	1.99	H	92.10	1.51	H	91.74	1.62	H
TLE	90.50	1.86	H	91.56	2.73	H	91.03	1.92	H
MAPEH	84.62	4.15	A	87.31	4.68	A	85.96	4.22	A
Phy Sci	90.00	1.46	H	90.93	1.71	H	90.47	1.37	H
SpEd	89.47	1.73	H	91.75	1.65	H	90.66	1.32	H
Gen Ed	91.89	1.18	H	92.32	1.23	H	92.11	0.97	H
HELE	92.71	1.27	H	93.05	1.36	H	92.88	1.18	H
ECE	92.33	1.37	H	92.94	1.21	H	92.64	0.94	H

Further, whether grouped as to programs or by semesters, high level of teaching competence was exhibited by the PSTs with mean scores ranging from 89.47 to 93.05.

When grouped as to specializations, all groups of PSTs obtained a high level of teaching competence during both semesters, with mean scores ranging from 89.47 to 93.05. The MAPEH group, whether overall performance ( $M = 85.96$ ) or by semester ( $M_s = 84.62, 87.31$ ), registered an average level of teaching competence. The nature of the course, which is characterized by physical dexterity, may have come into the way of student teaching activities of this group of PSTs.

#### Level of Performance in the LET

Generally, as shown in Table 4, the graduates obtained an average level of performance in the LET ( $M = 76.17$ ). This overall level is attributed to the average levels of performance they obtained in the three curricular components of the LET, namely, general education ( $M = 76.40$ ), professional education ( $M = 73.63$ ), and major courses ( $M = 77.02$ ).

Further, when grouped as to program, both the BEEd and BSEd graduates registered an average level of performance with mean scores ranging from 76.07 and to 76.29, respectively.

**Table 4**  
*Performance of the Graduates in the LET*

Variable Groupings	Performance in Licensure Examination for Teachers											
	General Ed			Professional Ed			Major			Overall		
	M	SD	Desc	M	SD	Desc	M	SD	Desc	M	SD	Desc
<b>Overall</b>	76.40	5.31	A	73.63	6.27	A	77.02	5.75	A	76.17	5.07	A
<b>Program</b>												
BSEd	75.51	6.07	A	75.95	5.31	A	77.02	5.75	A	76.29	4.60	A
BEEd	77.15	4.47	A	75.37	7.00	A				76.07	5.45	A
<b>Major</b>												
Math	76.27	4.52	A	74.27	5.75	A	82.00	7.78	H	76.77	4.89	A
English	79.14	4.49	A	80.05	3.88	H	79.00	2.28	A	79.45	2.70	A
TLE	71.67	6.98	A	73.50	6.37	A	73.50	6.69	A	73.13	5.75	A
MAPEH	72.15	5.10	A	73.54	3.57	A	76.31	4.73	A	74.37	3.22	A
Phy Sci	77.40	4.95	A	76.47	2.95	A	75.47	3.66	A	76.25	2.69	A
SpEd	77.56	4.00	A	76.38	3.22	A				78.05	3.13	A
Gen Ed	76.58	4.15	A	73.89	6.59	A				74.95	5.15	A
HELE	79.67	3.51	A	75.43	10.30	A				77.12	7.35	A
ECE	75.06	5.35	A	75.72	4.78	A				75.46	4.73	A

When grouped as to major fields, an average level of LET performance was obtained by all specializations with mean scores ranging from 73.13 to 79.45. The English group exhibited high level of performance in professional education courses ( $M=80.05$ ), and the Mathematics majors obtained high level of performance in the major courses ( $M = 82.00$ ).

The data further show that the collective per-

formance of the sampled groups like TLE ( $M=73.13$ ), MAPEH ( $M=74.37$ ), and General Education ( $M=74.95$ ) did not meet the LET cut off passing mark of 75.00. This finding points to the weakest link in the board performance of the graduates.

#### Difference in the Self-Assessed Teaching Competence of the PSTs

When the PSTs were categorized as to programs, significant difference was shown between their student teaching competence levels ( $t = -4.319, p < .01$ ), with the BEEd group exhibiting better teaching competence (Table 5).

This can be taken to show that the prospective elementary teachers perceived themselves to be better

**Table 5**  
*Difference in the Self-Assessed Teaching Competence of the PSTs Grouped as to Programs and Student Teaching Periods*

Variable Groupings	M	Student Teaching Competence			Findings
		t-value	df	p-value	
<b>Programs</b>					
BSEd	4.19	-4.319**	169	0.000	Significant
BEEd	4.42				
<b>Student Teaching Periods</b>					
First Semester	4.26	-2.698**	170	0.008	Significant
Second Semester	4.37				

\*\* $p < .01$

student teaching performers. The significant difference in the levels of teaching competence of the PSTs showed that the program where they were enrolled and the student teaching phase are factors in their teaching competence. When their competence was compared as to training periods, significant difference was noted and it was during the second semester where they registered better performance ( $t = -2.698, p < .01$ ). It can be deduced that the realities of the student teaching program, where the PSTs were assigned to another venue or school and were exposed to another new learning environment, another supervising teacher, another set of learners, new subjects to be taught, and a host of many other factors caused the possibility of obtaining lower or higher level of teaching competence during the second semester.

Further analysis of data (Table 6) showed that there was significant difference in the levels of teaching competence of the PSTs as assessed by them when they were grouped as to specializations ( $F = 3.371, p < .01$ ). Using the post hoc analysis indicated that significant differences were noted between MAPEH and General Education Majors, in favor of



English group, and TLE and MAPEH, with TLE having better teaching competence.

Table 6  
*Difference in the Self-Assessed Teaching Competence of PSTs When Grouped According to Specializations*

	Sum of Squares	df	Mean Square	F	p-value	Finding
Between Groups	3.215	8	.402	3.371**	.001	Significant
Within Groups	19.313	162	.119			
Total	22.528	170				

\*\*p < .01

Table 7  
*Post Hoc Results on the Difference of Self-Assessed Teaching Competence as to Specializations*

Specialization	Mean Differences	Std. Error	p-value	Findings
MAPEH & Gen Ed	-6.6674**	.11094	.001	Significant
English & MAPEH	-4.95908**	.12185	.007	Significant
TLE & MAPEH	-4.3774**	.12567	.008	Significant

\*\*p < .01

*Difference in the Assessment of the STs of the Teaching Competence of PSTs*

This study (as indicated in Table 8) established the fact that the BSEd and BEEd PSTs differed significantly in their teaching competence acquired during OYST as assessed by the STs ( $t = -.4554$ ,  $p < .01$ ), with the BEEd group having better teaching competence. The finding indicated that, while the PSTs were subjected to common student teaching evaluation instrument used by the STs, the difference in education levels, the nature of teaching and learners, and a host of other circumstances must have contributed to the development of their teaching competence in student teaching.

Table 8  
*Difference in ST-Assessed Teaching Competence of PSTs*

Variable Groupings	N	Student Teaching Competence			
		t-value	df	p-value	Findings
<b>Programs</b>					
BSEd	90.42	-4.554**	169	0.000	Significant
BEEd	92.13				
<b>Student Teaching Periods</b>					
First Semester	90.90	-5.843**	170	0.006	Significant
Second Semester	91.81				

\*\*p < .01

When their teaching competence was compared according to the training periods, significant difference was noted ( $t = -.5.843$ ,  $p < .01$ ) and it was during the second semester training where they performed better. This finding also indicated that the additional one semester of student teaching afforded the PSTs with opportunity to all the more improve their instructional delivery practices and enhance the development of their teaching competence.

Further analysis of data (Table 9) showed that there was significant difference in the levels of teaching competence of the PSTs as assessed by the STs when the PSTs were grouped as to specializations ( $F = 20.256$ ,  $p < .01$ ).

Table 9  
*Difference in the Teaching Competence of PSTs in OYST According to Specializations as Assessed by STs*

	Sum of Squares	df	Mean Square	F	p-value	Finding
Between Groups	509.496	8	63.687	20.256**	.000	Significant
Within Groups	509.349	162	3.144			
Total	1018.845	170				

\*\*p < .01

Using the post hoc analysis employing Tukey Test to determine where the significant differences lie indicated that, as to the BSEd groups, significant differences were noted between Mathematics and MAPEH, in favor of the Mathematics group; English and MAPEH, in favor of the English group; TLE and MAPEH, in favor of the TLE group; and Physical Science and MAPEH, in favor of the Physical Science majors. With regards BEEd groups, significant differences in the student teaching competence were noted between SPED and HELE, with the HELE group having better competence; and SPED and ECE majors, with ECE majors having better teaching competence.

Table 10  
*Post Hoc Results on the Difference of Teaching Competence as to Specializations*

Specialization	Mean Differences	Std. Error	p-value	Findings
Mathematics & MAPEH	-6.17483**	.72642	.000	Significant
English & MAPEH	-5.77656**	.62576	.000	Significant
TLE & MAPEH	-5.06624**	.64539	.000	Significant
Physical Science & MAPEH	-4.50513**	.67191	.000	Significant
SPED & HELE	-2.22470**	.58841	.007	Significant
SPED & ECE	-1.98264*	.60925	.036	Significant

\*\*p < .01

\*p < .05

### Difference in LET Performance

When the BEEd and BSEd graduates were compared in terms of their performance in the LET, no significant difference was noted ( $t = 0.284, p > .05$ ) and this indicated that both groups performed more or less at the same level in the board examination.

**Table 11**  
*Difference in the LET Performance as to Programs*

Variable Groupings	Performance in the Licensure Examination				
	<i>M</i>	t-value	df	p-value	Finding
<b>Programs</b>					
BSEd	76.29	0.284	169	0.777	Not Significant
BEEd	76.07				

Analysis of data also showed that there was significant difference in the levels performance of the PSTs in the LET when they were grouped as to specializations ( $F=3.249, p < .05$ ). The post hoc analysis using Tukey Test which was used to determine where the significant differences lie indicated that, as to the BSEd groups, significant difference was noted between English and TLE majors, with English majors having better performance. The English and General Education majors differed significantly in their board performance, in favor of the English majors.

**Table 12**  
*Difference in the LET performance as to Specializations*

	Sum of Squares	df	Mean Square	F	p-value	Finding
Between Groups	603.425	8	75.428	3.249*	.002	Significant
Within Groups	3761.46000	162	23.219			
Total	4364.885	170				

\*  $p < .05$

**Table 13**  
*Post Hoc Results on the Difference in LET Performance as to Specializations*

Specializations	Mean Differences	Std. Error	p-value	Finding
English and TLE	6.31429**	1.54777	.002	Significant
English & Gen Ed	4.50025*	1.31022	.021	Significant

\*\* $p < .01$

\*  $p < .05$

### Relationship Between Teaching Competence and LET Performance

A positive and significant relationship (Table 14) was noted between the teaching competence devel-

oped by the PSTs in OYST as assessed by the STs and their performance in the LET ( $r = .153, p < .05$ ). The finding indicated that there is a causal evidence to show the influence of OYST on the acquisition and further development of the teaching competence and on achieving license to teach as professional teachers.

**Table 14**  
*Relationship Between the Teaching Competence of the PSTs and LET Performance*

	Performance in the LET		
	r	r Probability	Finding
Student Teaching Competence	0.153*	0.046	Significant

\*  $p < .05$

## FINDINGS

The following are the findings of the study:

1. Generally, the PSTs assessed their teaching competence in one year student teaching to be at a very high level. Very high level of teaching competence was how they rated themselves during the first and second semesters of training. The BEEd group rated themselves to have a very high level of teaching competence both during the first and second semesters. Their BSEd counterpart rated their teaching competence to a high level during the first semester. However, during the second semester, they felt their teaching competence raised to a very high level. All specializations under the BEEd program such as General Education, HELE, ECE, and SPED believed they exhibited a very high level of teaching competence both during their first and second semesters. All majors under the BSEd program obtained a high level of teaching competence during the first phase of student teaching. Except for TLE and MAPEH majors who maintained a high level of teaching competence, the English, Physical Science, and Mathematics groups raised their level of teaching competence to a very high level during the second phase of immersion to actual teaching.

2. Generally, as assessed by the STs, the PSTs obtained a high level of student teaching competence and this is one level lower than the assessment of the PSTs. This is attributed to the high level of competence registered during the first and second semesters of training. Whether grouped as to programs or by semesters, high level of teaching competence was exhibited by the PSTs. When grouped as to specializations, all groups of PSTs obtained a high level of teaching competence during both semesters. The MAPEH group, whether overall performance or by

semesters, registered an average level of teaching competence.

3. Generally, the graduates obtained an average level of performance in the LET. This overall level is attributed to the average levels of performance they obtained in the three curricular components of the LET such as general education, professional education, and major courses. When grouped as to program, the BSEd PSTs registered an average level of performance in the three components of the LET. The BEEd group also obtained an average level of LET performance in the general education and professional education courses, the only two curricular components included in the LET for elementary teachers. When grouped as to major fields, an average level of LET performance was obtained by all specializations. The English group exhibited high level of performance in professional education courses, and the Mathematics majors obtained high level of performance in the major courses. It was shown that the collective performance of the sampled groups like TLE, MAPEH, and General Education did not meet the cut off passing mark of 75% of the LET. This finding points to the weakest link in the board performance of the sampled PSTs.

4. When the PSTs were categorized as to programs, significant difference was shown between their student teaching competence levels as assessed by them, with the BEEd group exhibiting better teaching competence. When their competence was compared as to training periods, it was during the second semester where they registered better performance. There was significant difference in the levels of teaching competence of the PSTs when they were grouped as to specializations. The post hoc analysis indicated that significant differences were noted between MAPEH and General Education Majors, in favor of the later, English and MAPEH, in favor of English group, and TLE and MAPEH, with TLE having better teaching competence.

5. The BSEd and BEEd PSTs differed significantly in their teaching competence acquired during OYST as assessed by the STs. When their teaching competence was compared according to the training periods, significant difference was noted and it was during the second semester training where they performed better. There was significant difference in the levels of teaching competence of the PSTs when they were grouped as to specializations. The post hoc analysis indicated that, as to the BSEd groups, significant differences were noted between Mathematics and MAPEH, in favor of the Mathematics group; English and MAPEH, in favor of the English group; TLE and MAPEH, in favor of the TLE group; and Physical Science and MAPEH, in favor of the Physical Science majors. As regards BEEd groups, significant differences in the student teaching competence were noted

between SPED and HELE, with the HELE group having better competence; and SPED and ECE majors, with ECE majors having better teaching competence.

6. No significant difference was noted between the LET performance levels of the BEEd and BSEd graduates. There was significant difference in the levels performance of the PSTs in the LET when they were grouped as to specializations. As to the BSEd groups, significant difference was noted between English and TLE majors, with English majors having better performance. The BSEd -English and BEEd-General Education majors differed significantly in their board performance, in favor of the English majors.

7. A positive and significant relationship was noted between the teaching competence developed by the PSTs in OYST and their performance in the LET.

## CONCLUSIONS

The following are the conclusions made based on findings:

1. The PSTs viewed themselves as possessing teaching efficacy being highly competent and very high performers in one year student teaching.

2. The STs assessed the teaching competence of the PSTs one level lower than their self-assessment and they were rated as high performers in one year student teaching.

3. The immersion of the pre-service teachers to another semester of student teaching all the more improved their teaching competence.

4. Programs enrolled, specializations, and student teaching periods are factors in the development of student teaching competence.

5. As education graduates, generally, they were average performers in the LET, but particularly, the TLE, MAPEH, and General Education as groups fall short of the passing cut-off score of the examination.

6. Whether they are BEEd or BSEd PSTs did not affect their performance in the LET but their specializations are factor in their LET performance.

7. Student teaching competence developed within one year student teaching influenced the performance of graduates in the board examination.

## RECOMMENDATIONS

This study offered the following recommendations:

1. Opportunities to maximize the development of teaching efficacy or competence among the pre-service teachers can be provided through continuous review and enrichment of the teacher education curriculum and of the delivery system of instruction, specifically that of the student teaching program.

2. Screening mechanism for entrants to the various TEPs can be reviewed to establish admission standards vis-à-vis immersion to responsive instructional activities across programs and specializations to be comparable with others in their level of teaching competence and board performance, considering that some specializations do not fare well in the LET.

3. The teaching competence areas or practices where the PSTs were found to be needing more improvement can be looked into as pivotal point for the implementation of relevant enhancement program to all the more increase their competence level and passing performance in the LET.

4. Immersion of PSTs to another semester of student teaching is one best practice in teacher training that is worth-implementing to enhance teaching efficacy and board performance much more so with the unfolding curriculum-decongestion in tertiary education with the implementation of K to 12 program. Lengthening of student teaching to two semesters may be considered in the development of the teacher education curriculum.

5. The performance of the graduates in the board examination whether by programs, specializations, and curricular components deserves the needed look in any attempt for continuous improvement in the implementation of the teacher education curriculum to be responsive to the demands of licensure examination.

6. Similar and relevant studies may be conducted to cover other pre-service teachers of external campuses and of other TEIs, whenever applicable, that focus on other variables which interplay with the contribution of OYST to the performance of the graduates in the licensure examinations or in professional teaching.

## LITERATURE CITED

Bandura, A. (1986). *Social foundations of thought and action: A social cognitive theory*. Englewood Cliffs, New Jersey: Prentice Hall.

Buitink, J. (2009). What and how do student teachers learn during school-based teacher education? *Teaching and teacher education*, 25,118-127. Doi: 1016/j.tate.2008.07.009; Zeichner, K. & Schulte www.icctejournal.org/issues/v612-hoskins-schuetter-charlton/.

Commission in Higher Education Memorandum Order No. 30, s. 2004 on Revised Policies and Standards for Undergraduate Teacher Education Curriculum.

Dayagbil, F., Abao, E., Lapingcao, N., Polinar, D., Laplap, F., Villareal, N., Borado, H., Inocian, R., and Olvido, M. (2012). *Special topics in education*, Volume 3. Quezon City: Lorimar Publishing

Dinagsao, A.V. (2013). *Pre-service teachers: Are they prepared for the real job?* Conference.pixel-online.net/foe2013/common/download/Abstract-pdf247-SOE64-ABS-Vedua-Dinagsao-FOE2013.pdf.

Gerundio, Maribel G. & Balagtas, Marilyn U. (2014). Exploring Formula for Success in Teachers' Licensure Examination in the Philippines, *Educational measurement and evaluation review*, Vol. 5, 104-117.

Giallo, Rebecca and Little, Emma. (2003). Classroom Behavior Problems: The relationship Between Preparedness, Classroom Experiences, and Self-Efficacy in Graduate and Student Teachers, , Vol. 3, *Australian journal of education and development psychology*. Retrieved December 5, 2015 from [https://www.newcaslt.edu.au/\\_data/assets/pdf\\_file/0017/100484/v3-giallo-little.pdf](https://www.newcaslt.edu.au/_data/assets/pdf_file/0017/100484/v3-giallo-little.pdf).

Gibbs, Collin. Effective teaching: *Exercising self-efficacy and thorough control action*. Retrieved December 10, 2015 from [www.leeds.ac.uk/educol/documents/00002390.htm](http://www.leeds.ac.uk/educol/documents/00002390.htm).

Hammond, Linda, D. (2000). How teacher education matters? *Journal of teacher education*, May 2000, Vol. 51, No. 3. Retrieved December 10, 2015 from <http://jte.sagepub.com/content/51/3/166>.

<http://education-teaching-careers.knoji.com/how-to-pass-the-licensure-examination-for-teachers-let/>. Retrieved February 19, 2016.

Kant, R. (2011). *A study of teaching aptitude and responsibility feeling of secondary school teachers in relation to their sex and local*. Retrieved October 15, 2013 from [www.savap.org.pk/journals/ARInt/Vol.1\(2\)/2011\(1.2-25\).pdf](http://www.savap.org.pk/journals/ARInt/Vol.1(2)/2011(1.2-25).pdf)

Pagoso, C., Garcia, G. & De Leon, C. (1992). *Fundamental statistics for college students*. Manila: Sinag-tala Publishers.

Plourde, L. (2002). The influence of student teaching on pre-service elementary teachers' science self-efficacy and outcome expectancy beliefs. *Journal of instructional psychology*, 29(4),245-523; in Hoskins, J., Schuette, C. and Charlton, M. Program Improvement and Practice: In-Service and Pre-Service Student Teaching Reflections, *Journal of the International Christian Community for teacher education*, [ictejournal.org/issues/v612-](http://ictejournal.org/issues/v612-) Hoskins, J., Schuette, C. and Charlton/.

Republic Act 7836, the Philippine Teachers Professionalization Act of 1994

[www.journals.savap.org.pk](http://www.journals.savap.org.pk)).

[www.utpa.edu/colleges/coe/ofe/docs/InternhandbookSp13.pdf](http://www.utpa.edu/colleges/coe/ofe/docs/InternhandbookSp13.pdf).

# DESIGN OF A GENERATOR BOOSTER FOR A LOW FLOW RATE WATER SYSTEM

GILLERT M. BONGCAC

College Instructor, Jose Rizal Memorial State University  
Main Campus, Dapitan City, Philippines

## ABSTRACT

*This study presents a design of a generator booster for used in the household which has very low flow rate of water system. The output of the design exhibits voltage and current outputs which was directly proportionate to the flow rate of the water flow. The efficiency of the picohydro generator booster is sufficiently and sustainably for purpose of portable used in the household or in any low flow rate water system as a source of energy to turn the generator.*

**Keywords:** *Low flow rate generator booster, Picohydro generator booster, Portable generator booster, Booster design using Matlab and LTSpice.*

## INTRODUCTION

Electricity is the most versatile and widely used form of energy since it is applicable in all types of device and appliances. The global demand for electricity is continuously growing. Availability of useable energy in the form of electricity has gradually assumed an essential component of our daily lives. Our study is about renewable energy that focuses in hydroelectric power application to convert stream flow of water into electrical energy.

To demonstrate the feasibility of Pico-hydro plant, the water reservoir having sufficient capacity may be kept few meters above the ground. The water flows downhill through the penstock. The potential for energy production in a hydropower plant is determined in amount of water available, hydraulic losses on water transport due to friction and velocity change and the efficiency in energy conversion of electromechanical equipment (Dhanjode & Nimje, 2015). Control methods may be used to maximise efficiency in varying flow conditions, but as these will increase the expense and complexity of the system, the control requirements must be balanced against the improvement in power output (Asim et. al, 2012). As the head increases, the power density of the impulse turbines and waterwheels improves, whilst that of the Archimedes Screw decreases. As the head increases then the speed of the impulse turbine increases, so removing the need for a gearbox, increasing the overall efficiency of the turbine.

For impulse turbines, proper speed ratios are essential for efficiency energy transfer from the water jet to the generator shaft. A second consideration pertaining to speed ratio that must be considered is the shift in peak efficiency due to low turbine efficiency. The further the turbines' maximum efficiency deviates from the ideal conditions, the lower the optimal speed ratio becomes. A standardized turbine housing

with built in nozzle mounts would simplify alignment. The housing would need to allow for large scale adjustments to accommodate different turbine sizes, as well as for fine adjustments to optimize the position during testing. Efforts should be made to minimize these types of flow disturbances but nozzle selection is much more important for jet quality, (Cobb, 2011).

The existing design of portable Pico hydro generator is used. The problem is only too small of power is generated since there is only small amount of flow rate in a water system of a household water consumer, to address these problems we aim to develop a booster that is capable of amplifying power output in order to supply a minimum load of 20mA.

## Objective of the Study

1. To design and develop portable Pico hydro generator booster for a low flow rate water system.
2. To verify the design through Matlab and LTSpice simulation.
3. To evaluate the efficiency of the Generator Booster design.

## METHODOLOGY

### Research Design

A design of portable Pico hydro generator is use with a booster, using of water supply as a source of energy to produce another type of energy from mechanical to electrical. In power generation from water it uses both head and flow of water. This head will be the difference in water intake and turbine. The proposed design is consists of a turbine, dc motor as generator, battery and boosters.

## Research strategy and Research design

Experimental design is use on the evaluation of the controlled independent variable to investigate its effect in the dependent variable. A collection of data from different level of head that is consider as input on the device. Voltage from different level of head are measured to obtain an idealize design of boosters base on the measurement. A minimum of 1m head is required, flow rate and torque are consider as independent variables, the flow rate is consider as independent variable since torque is dependent on the flow rate. The overall dependent variable is the output voltage and current of the design booster based on assume range of generator output voltage from 1 V to 1.5 V.

## Collection, Measurement, Process, and Analysis

In measuring the gross head of the system pressure-gauge method is use since the propose system is consider as low head. This method for measuring head relies on the fact that for every meter vertically below the free surface of water pressure increases by 9.84 kPa, independent of the shape of the container which confines the water. The elevation difference (gross head) “ $H_g$ ” between the free water surface and the pressure gauge can be equated by

$$H_g = \frac{P_g}{9.8} \quad (\text{Eqn 1})$$

Measuring head using this method requires long flexible tubing with its one end connected to the gauge. After the tubing is filled with water, the pressure reading of the gauge is done and applying the formula above will give an approximate estimate of the head. For measuring the water flow rate of the system container method is use in very small stream, since the system is small scale Pico hydro system. This method involves recording the amount of time required for the discharge in the stream to fill the bucket. With  $V_c$  the volume of the container and  $t$  the time taken for the container to be filled, the discharge in the stream is found to be

$$Q:Q=V_c/t \quad (\text{Eqn 2})$$

Be sure to record the time in second when the container is already full.

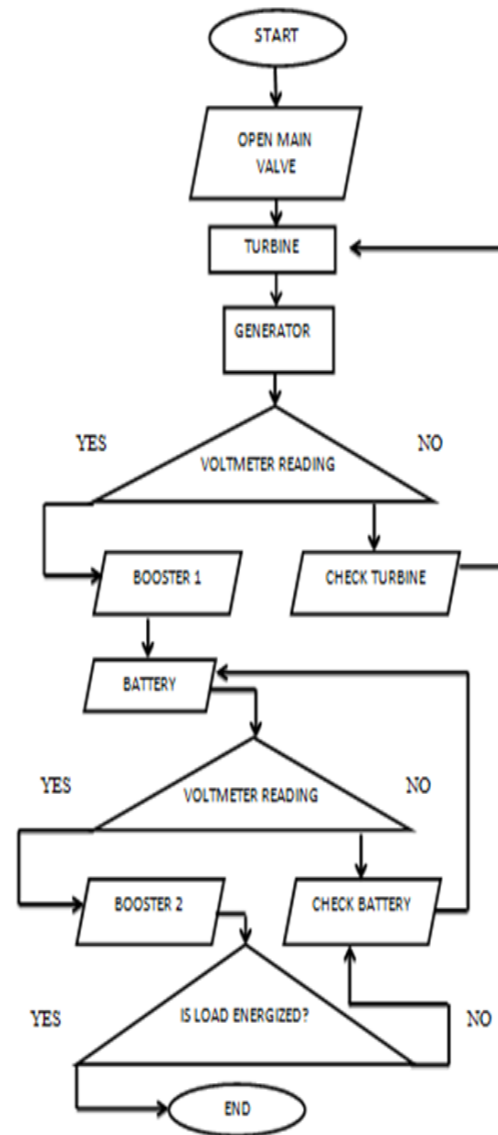

Figure 1 Design Flow Chart

## Modelling and Simulation

This part of the proposal will contain all the data that is required in performing the simulation that is needed to verify the objective of the study. It also includes the results of simulation as an evaluation on the desired outcome specified in the objectives.

**Working Equation**

Ohm's Law  
 $V = IR$  (Eqn 3)

Regulator Output Voltage  
 $V_{OUT} = V_{REF} (1 + \frac{R2}{R1})$  (Eqn 4)

Flow rate  
 $Q = \frac{V}{t}$  (Eqn 5)

Generator  
 $P_{in} = H \times Q \times g$  (Eqn 6)

$P_{out} = H \times Q \times g \times \eta$  (Eqn 7)

Table 1: Result of Simulation at Different Flow Rate

Flow rate(L/s)	Generator voltage output(V)	Generator current output (mA)	Booster voltage output(V)	Booster current output (mA)
0.25	1.723	287.73	5.14	64.288
0.35	2.213	389.67	6.642	83.028
0.45	2.835	361.931	8.597	107.684
0.65	3.165	374.886	9.575	119.684
0.85	3.75	473.223	11.442	143.030

**FINDINGS AND INTERPRETATION**

**Design of the Portable Pico Hydro Generator Booster**

A simulation is done in the generator side using the model of dc generator with flow rate as independent variable to obtain a result of voltage, and current.

Fig 2: DC Generator Model using Matlab

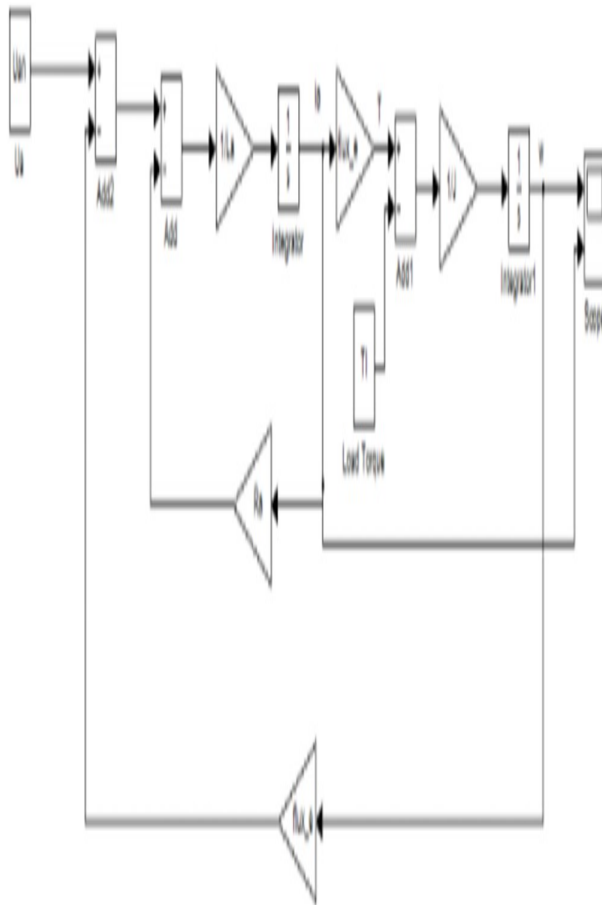

The table above represent the result of simulation in the generator side with respect to the variable input of flow rate. The flow rate is assumed base on the specific household water supply.

**Verification of the Design using LT Spice**

A simulation of booster is done using the result of table 1. Using the design booster input the different values of voltage generated at the input side of the circuit.

Fig 3: Booster Design using LT Spice

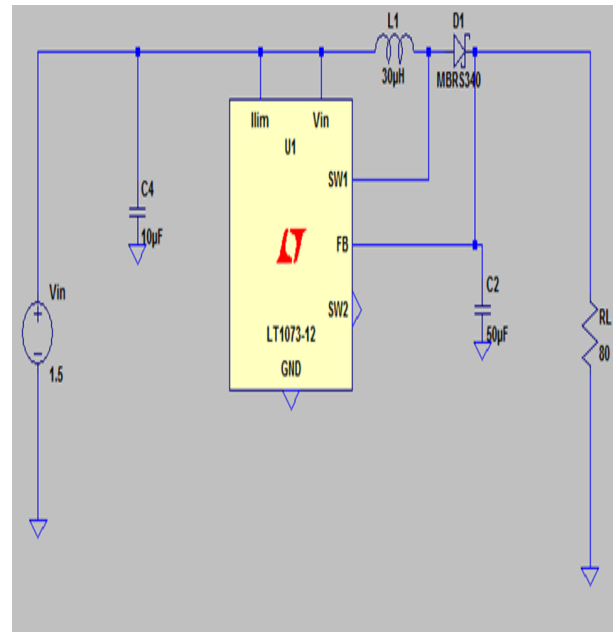



The circuit is design to boost the given output of the generator at different sample of flow rate.

The table represent the result on simulation of the booster circuit from an input of voltage generated of picohydro generator at different flow rate level.

### Computed Efficiency

The efficiency is calculated based on the generator power output and the booster power output.

Table 2: Booster Efficiency

Flow Rate	Generator Power Output (W)	Booster Power Output (W)	Efficiency (%)
0.25	0.494	0.329	66.67
0.35	0.861	0.550	68.88
0.45	1.323	1.139	71.91
0.65	1.584	1.139	71.91
0.85	1.930	1.636	84.77

Table 2 shows the result in every simulation with respect to the generator and booster. The efficiency results in the table 2 represent the efficiency of the design booster. This means that as the power booster is increase with respect to the flow rate, the efficiency of the design booster increases. The flow rate is directly proportional to the generator power and to the boaster power.

### CONCLUSION

Based on the results and findings, the following conclusions are drawn;

1. The design of the portable picohydro generator booster exhibits power energy amplification that can supply very small flow rate of water system.
2. The simulated verification of the picohydro generator booster using Matlab and LTSpice demonstrates the increase of parametric values that signifies the output performance of the design.
3. It is shown in the results that the efficiency of the design is efficient enough to be used as portable generator booster.

### REFERENCES

- Asim, et al (2012). Research and development aspects of Pico hydro power
- +Cobb, (2012). Experimental Study of Impulse Turbines and Permanent Magnet Alternators for Pico-hydropower Generation
- Hermann, (2006): Design of a micro Hydro Powered battery charging system for rural village electrification.
- Dhanjode and Nimje, A (2011). Hydropower From Small and Low-Head Hydro Technologies. Nova Science Publishers Incorporated.

# INTEGRATING E-MODULE AS A TOOL IN TEACHING CONCEPTS OF SIGNIFICANCE LEVEL IN EDUCATIONAL STATISTICS FOR GRADUATE STUDENTS

MELANIE G. GURAT

Faculty, Mathematics Department and Junior Statistician, University Research Center;  
Saint Mary's University  
Bayombong, Nueva Vizcaya, Philippines

## ABSTRACT

*The need to understand statistics in conducting research is very important especially when working on quantitative data. A very important concept that needs to be fully understood particularly in hypothesis testing is the significance level. Collado (2015) found out that graduate students have a fair level of understanding of the concepts of significance level; thus she constructed an e-module on the said topic designed for use by graduate students. The e-module was used in conducting true experimental design particularly randomized pretest-post test control group design with two classes of graduate Statistics to compare instructions with e-module and without e-module. The class with e-module was only given brief discussion on the interventions, while the group with e-module was taught with pure lecture method. The students taught with e-module obtained relatively higher scores than the students taught without the e-module only in one cluster of the lesson. After controlling the initial differences in scores, there was no significant difference in the mean scores of graduate students who differ in sex and intervention revealing further that e-module can be a substitute to lecture method. This implies that e-module could reinforce graduate students' independent learning and could help them cope with the lessons missed in class. E-module can also be taught in combination with the traditional methods to better improve the understanding about the level of significance.*

*Keywords: e-module, significance level, statistics, true experimental, Graduate Students*

## Introduction

Statistics is a structural method in solving a problem and frequently used in various fields (Sahari, et al., 2009). Statistics is the systematic collection and analysis of numerical data, in order to investigate or discover relationships among phenomena so as to explain predict and control their occurrence. Statistics is divided into two branches: Descriptive and Inferential Statistics (Harris, 2007). Descriptive statistics are used in everyday life in areas such as government, healthcare, business, and sport while Inferential (analytical) statistics makes inferences about populations (entire groups of people or firms) by analyzing data gathered from samples (smaller subsets of the entire group), and deals with methods that enable a conclusion to be drawn from these data and investigates whether the data are consistent with that hypothesis (Harris, 2007).

It is important for researchers to understand statistics so that they can be informed, evaluate the credibility and usefulness of information, and make appropriate decisions. Some of the major purposes of statistics are to help us understand and describe phenomena in our world and to help us draw reliable conclusions about those phenomena (Baltimore County Public Schools, 2010).

With these importance mentioned, it is stated in CHED memo no. 53, series of 2007 on policies and standards for graduate programs in education for teachers and other education professionals as part of the goal of Graduate education that:

*...Graduate education is also one of the most effective means of developing capacities related to doing research that will improve educational theory and practice in the many different aspects of the educational process...*

Aside from that, the curriculum outline found in the same document includes 9 units of core/foundation courses for both thesis and non-thesis program which includes 3 units Statistics, 3 units methods of research and 3 units that depends on students' major. Hence, Commission on Higher education requires the graduate students to take statistics course to prepare them in making research.

With these, the need to understand statistics in conducting research is very important especially when working on quantitative data. One of the basic concepts needs to be developed is the significance level because this is the guide of the researcher whether to accept or reject the null hypothesis stating that there

is no significant relationship/difference or correlation between and among the variables involved. However, methodologists constantly point out that researchers misinterpret  $p$ -values (Magnuson. nd). Furthermore, Collado (2015) in her study cited that significance level is a misleading term that many researchers do not fully understand (Creative Research Systems, 2014), thus some researchers misinterpret their research' results (Bruce, 1994) and so her study aimed to investigate the level of understanding on significance level by graduate students who took statistics and would probably write their thesis or dissertation. She found out that graduate students have a fair level of understanding on the concepts of significance level revealing that they have fairly correct notions about levels of significance so as part of her problem, a module, on significance level with particular focus on specific levels of significance and its importance is designed for use of graduate students. Since the module was only part of her problem, the effectiveness of the module was not yet checked. Thus, this study aimed to determine the effectiveness of integrating the e-module as a tool in teaching significance level in educational statistics for graduate students.

### Statement of the Problems

The purpose of this study was to determine the effectiveness of the e-module as a tool in teaching among the graduate students enrolled in Statistics during the first semester, school year 2015-2016. Specifically, this study aimed to answer the following questions:

1. What is the level of understanding on concepts about significance level of the students in the 2 classes of Statistics taught before and after the intervention a) with e-module and b) without e-module?
2. Is there a significant difference between the mean gained score (total and per cluster) of students when grouped by intervention?
3. After controlling the initial differences in scores, is there significant difference in the mean score of graduate students who differ in sex and intervention?

### Methodology

This study employed true experimental design particularly the randomized pre-post test control group design. The design used in the study was shown below.

This study also used descriptive-comparative type of research. The subjects of the study were the students enrolled in graduate Statistics during the first semester, SY 2015-2016. To compare the effectiveness of the instruction with e-module and without e-module,

Group	Pre-test	Teaching Method	Post-test
A	O <sub>1</sub>	With e-module	O <sub>2</sub>
B	O <sub>3</sub>	Without e-module	O <sub>4</sub>

Legend: O<sub>1</sub> and O<sub>3</sub> – pretest, O<sub>2</sub> and O<sub>4</sub> – post test

random sampling on larger class was performed to have equivalent number of samples. This is in consideration of conditions that need to meet in using statistical test. The class with e-module was only given brief discussion on the interventions, while the group with e-module was taught with pure lecture method.

The study made use of assessment test on level of understanding on level of significance that serves as pre-test and post-test adopted from Collado(2015) with a Cronbach's alpha of 0.702. The reliability in the current study was 0.876.

### Findings

Section 1. Level of Understanding on Concepts about Significance Level of the Students enrolled in Statistics Class Taught with E-module and without E-module Before and After the Intervention.

Table 1.1 Level of Understanding on Concepts about Significance Level of Students in Statistics Class Taught Before and After the Intervention with E-module and without E-module.

Level	With e-module		Without	
	Before f (%)	After f (%)	Before f (%)	After f (%)
P	2 (8.3)	0 (0)	0 (0)	0 (0)
F	16 (66.7)	4 (16.7)	7 (70)	0 (0)
M	6 (25)	7 (29.2)	3 (30)	5 (50)
G	0 (0)	6 (25.0)	0 (0)	5 (50)
VG	0 (0)	7 (29.2)	0 (0)	0 (0)
Total	24 (100)	24 (100)	10 (100)	10 (100)

P(poor); F(fair); M(moderate); G(great); VG(vary great)

The interventions conducted in the two classes have changed the level of understanding of students in statistics class from poor-moderate to fair-great understanding. This indicates that there was a level up on understanding concepts about significance level of students in statistics class after the interventions.

Based on the frequency count and percentage, the interventions performed were effective in increasing the level of understanding on significance level. The intervention with e-module can improve level until very great understanding compared with intervention without e-module; it can increase level until great understanding only.

Table 1.2 Descriptive Statistics of the Level of Understanding on Concepts about Significance Level of Students in Statistics Class Taught Before and After without E-module

Table 1.2 shows that the intervention without e-

Concepts	Before		After	
	MMd* (SD)	QD	MMd* (SD)	QD
a. Meaning of significance	33.3* (8.05)	F	68.33 (16.6)	G
b. Specific levels of significance	23.3 (14.1)	F	25.00 (16.2)	F
c. Importance of significance	33.8 (15.7)	F	65.00 (14.2)	G
d. Types of decision error	26 (10.8)	F	58.00 (20.4)	M
e. p value	55 (30.5)	M	61.67 (22.3)	G
f. confidence level	25* (26.4)	F	100* (21.1)	VG
Overall	33.7 (9.4)	F	58.16 (10)	M

Legend: 0-19.49 (Poor understanding/P), 19.5-39.49 (fair understanding/F), 39.50-59.49 (moderate understanding/M), 59.50-79.49 (great understanding/G) and 79.5-100 (very great understanding/ VG).  
\*not normally distributed

module can improve the level of understanding of the participants in the concepts on meaning of significance, importance of significance, types of decision error, p value and confidence level but not with specific levels of significance. Further lecture-discussion on specific levels of significance was needed to improve the level of understanding on specific levels of significance concepts.

Overall, the level of understanding of the participants increased from fair (M=33.69, SD=9.43) to moderate (M=58.16, SD=10.04).

Table 1.3 Descriptive Statistics of the Level of Understanding on Concepts about Significance Level of

Students in Statistics Class Taught Before and After Intervention with E-module

Concepts	Before		After	
	MMd* (SD)	QD	MMd* (SD)	QD
a. Meaning of significance	50* (20.3)	M	83.33* (23.5)	VG
b. Specific levels of significance	16.67* (16.3)	P	58.34* (32.6)	M
c. Importance of significance	29.17 (16.8)	F	64.58 (27)	G
d. Types of decision error	31.25 (14.8)	F	60.83 (24.1)	G
e. p value	41.67 (20.2)	M	66.67* (23.1)	G
f. confidence level	50* (35.1)	M	100.0* (40.8)	VG
Overall	32.13 (11.8)	F	64.26 (22.2)	G

Legend: 0-19.49 (Poor understanding/P), 19.5-39.49 (fair understanding/F), 39.50-59.49 (moderate understanding/M), 59.50-79.49 (great understanding/G) and 79.5-100 (very great understanding/ VG).

As \*not normally distributed

gleaned from table 1.3, the levels of understanding on concepts about significance level were improved in the statistics class taught with e-module. The result shows that 2 clusters were improved from moderate to very great. Overall, the level of understanding on concepts about significance level of students in statistics class taught with e-module improved from fair (M=32.13, SD=11.17) to great (M=64.26, SD 22.2).

Based on the results presented in table 1.2 and 1.3, the interventions performed were effective in increasing the level of understanding of students in concepts about significance level. The interventions without e-module can improve the level of understanding until moderate understanding only while with the aid of e-module, the level can be increased even until great level.

This was also showing that students have different understanding in the concepts of statistics with the difference in the level of understanding.

Section 2. Significant difference between the mean-gained score (the total and per cluster) when grouped by intervention.

Table 2.1 Significant difference between the mean gained score (the total and per cluster) when grouped by intervention in the randomized samples.

Cluster	Treatment	N	Mean (SD)	t(df) Sig. (2-tailed)
Meaning of significance	without	10	1.80 (1.14)	t(18)=-.88, p=.391
	with	10	2.40 (1.84)	
Specific levels of significance	without	10	1.10 (1.20)	t(18)=-2.88, p=.010**
	with	10	2.40 (2.22)	
Importance of significance	without	10	2.50 (1.84)	t(18)=-.41, p=.686
	with	10	2.90 (2.47)	
Types of decision error	without	10	3.20 (2.86)	t(18)=-.30, p=.771
	with	10	2.80 (3.19)	
p value	without	10	1.40 (2.41)	t(18)=-.67, p=.509
	with	10	1.10 (2.23)	
confidence level	without	10	1.30 (.67)	t(18)=1.74, p=.098
	with	10	.60 (1.08)	
Over all	without	10	9.30 (6.15)	t(18)=-.77, p=.453
	with	10	12.20 (10.24)	

\*significant at 0.05 level  
\*\*significant at 0.01 level

Table 2.1 reveals that there was no significant difference in the mean gained scores of students taught with or without e-module. Significant difference only existed in the concept of specific levels of significance,  $t(18)=-2.88$ ,  $p=0.010$ . The gained score of students taught with e-module was significantly higher only in concept of specific level of significance. Furthermore, the result also reveals that students taught with e-module have higher scores in some clusters but students taught without e-module have also obtained higher scores in others.

The study was supported by the result of the studies of Ramey (2015), Gundlach, Richards, Nelson, and Levesque-Bristol (2015) showing that the interventions such as e-module, fully online, flipped sections, used of instructional videos can improve the learning of students in statistics but no difference with traditional lecture-discussions.

Section 3. After controlling the initial differences in scores, is there significant difference in the mean score of graduate students who differ in sex and intervention.

Table 3.1 Descriptive Statistics of the Mean Score of Graduate Students who differ in Sex and Intervention after controlling differences in pre-test score

Sex	Treatment	Unadjusted Mean (SD)	N	Adjusted Mean
Female	Without	21.0 (4.08)	4	23.4 <sup>a</sup>
	With	24.0 (11.15)	6	24.2 <sup>a</sup>
	Total	22.8 (8.78)	10	
Male	Without	22.83 (3.82)	6	21.538 <sup>a</sup>
	With	25.00 (5.94)	4	24.253 <sup>a</sup>
	Total	23.70 (4.60)	10	

a. Covariates appearing in the model are evaluated at the following values: PRE = 12.500.  
Dependent Variable: POST

Table 3.1 shows that the mean score of students taught with e-module was higher than the mean score without e-module for both male and female graduate students.

Table 3.2. Significant difference in the mean score of graduate students who differ in sex and intervention after controlling the initial differences in scores  
Tests of Between-Subjects Effects  
Dependent Variable: POST

A 2 by 2 between-groups analysis of covariance was

Source	Type III Sum of Squares	F(df), Sig.	Partial Eta Squared
Corrected Model	79.75 <sup>a</sup>	F(4)=.37 p=.826	.090
Intercept	676.71	F(1)=12.56 p=.003	.456
PRE	42.83	F(1)=.80 p=.387	.050
Sex	2.42	F(1)=.05 p=.835	.003
Intervention	13.85	F(1)=.26 p=.620	.017
Sex * Intervention	3.60	F(1)=.07 p=.799	.004
Error	808.00		
Total	11699.00		
Corrected Total	887.750		

a. R Squared = .090 (Adjusted R Squared = -.153)

conducted to assess the effectiveness of the two interventions in improving the scores of students in the concepts of level of significance for male and female participants. The independent variables were the interventions (with e-module and without e-module) and sex.

The dependent variable was post test scores in level of significance. Pretest scores were used as a covariate to control for individual differences. The two-way effect of sex and intervention, main effect of intervention and main effect of sex were not significant. Similar to the result of

Liu and Garfield (2002). Furthermore, this also shows that since there was no significant difference, then e-module can be a substitute to lecture method especially that approaches in teaching graduate students were different from undergraduate students.

## Conclusions

Based from the result and discussions, the following conclusions were the following:

1. The interventions without e-module can improve the level of understanding until great understanding only while with the aid of e-module; the level can be increased even until very great level.
2. The understanding of the students taught with e-module and without e-module was the same except on specific levels of significance concept. The students taught with e-module learned better in the specific level of significance compared with students taught without the e-module. E-module can be substitute to lecture method.
3. After controlling the initial differences in scores, there was no significant difference in the mean score of graduate students who differ in sex and intervention.

## Recommendations

Based from the findings of the study, the following are recommendations:

- The e-module could reinforce them in independent learning.
- E-module could be a substitute to traditional learning. This can also help the graduate students to cope up with the lesson missed in class.
- E-module can be taught in combination with the traditional methods to better improve the understanding in the level of significance.
- Graduate teachers to continue integrating innovations in class and further studies could also be conducted.

## References:

Agus, M., Perú-Cebollero, M. Guàrdia-Olmos, J. and Penna, MP (2013). The measure-

ment of statistical reasoning in verbal-numerical and graphical forms: a pilot study. *Journal of Physics: Conference Series* 459 (2013) 012023  
doi:10.1088/1742-6596/459/1/012023

Ashaari, N.S. , Judi, H.M., Mohamed, H., Wook, T.M.T.W. (2011). Student's Attitude towards Statistics Course. *Procedia Social and Behavioral Sciences* 18 . Pp. 287–294. doi:10.1016/j.sbspro.2011.05.041. Available online at [www.sciencedirect.com](http://www.sciencedirect.com)

Baltimore County Public Schools (2010).Role of Statistics. Retrieved from [https://www.bcps.org/offices/lis/researchcourse/statistics\\_role.html](https://www.bcps.org/offices/lis/researchcourse/statistics_role.html)

Bouston University (2015). Why study statistics? Retrieved from <http://www.bu.edu/stat/undergraduate-program-information/why-study-statistics>.

Bude, L. (2006). Assessing Students' Understanding of Statistics.ICOT-7.

Capilla, C (2006). Assessing Students Reasoning about Statistical Measures and Association.ICOTS-7

Chan, S. & Ismail, Z.(2013). Assessing misconceptions in reasoning about variability among high school students.*Procedia - Social and Behavioral Sciences* 93. pp,1478 – 1483. doi: 10.1016/j.sbspro.2013.10.067. Available online at [www.sciencedirect.com](http://www.sciencedirect.com)

Collado, M. (2015).Level of Understanding on Concepts about Significance Levels among Graduate Students.Unpublished Thesis.

delMas, R., Ooms, A. & Garfield, J. (2006). Assessing Students' Statistical Reasoning.ICOTS-7.

Delmas,R., Garfield, J. Ooms, A. & Chance, B. (2007).Assessing Students' Conceptual Understanding after a First Course in Statistic.*Statistics Education Research Journal*, 6 (2), 28-58, <http://www.stat.auckland.ac.nz/serj>. International Association for Statistical

- International Association for Statistical Education (IASE/ISI), November, 2007
- Garfield, J. & Ben-Zvi, D. (2007). How Students Learn Statistics Revisited: A Current Review of Research on Teaching and Learning Statistics. *International Statistical Review* 75, 3, 372–396 doi:10.1111/j.1751-5823.2007.00029.x
- Gundlach, E., Richards, N., Nelson, D. and Levesque-Bristol, C (2015). A Comparison of Student Attitudes, Statistical Reasoning, Performance, and Perceptions for Web-augmented Traditional, Fully Online, and Flipped Sections of a Statistical Literacy Class. *Journal of Statistics Education* Volume 23, Number 1. [www.amstat.org/publications/jse/v23n1/gundlach.pdf](http://www.amstat.org/publications/jse/v23n1/gundlach.pdf)
- Liu, H. & Garfield, J. (2002). Sex Differences in Statistical Reasoning. Retrieved from [ojs.lib.ntnu.edu.tw/index.php/bep/article/viewFile/312/210](http://ojs.lib.ntnu.edu.tw/index.php/bep/article/viewFile/312/210)
- Harris, T. (2007). Why you need to use statistics in your research. Chapter 1. Dealing with Statistics. Kerry Press Ltd. McGraw-Hill. Retrieved from <https://www.mheducation.co.uk/openup/chapters/9780335227242.pdf>
- Magnusson, K. (nd). Understanding Statistical Power and Significance Testing. Retrieved from <http://rpsychologist.com/d3/NHST/>
- Nolan, M., Beran, T. & Hecker, K. (2012). Surveys Assessing Students' Attitude Toward Statistics: A Systematic Review of Validity and Reliability. *Statistics Education Research Journal*, 11(2), 103-123, <http://www.stat.auckland.ac.nz/serj>. International Association for Statistical Education (IASE/ISI), November, 2012
- Ramey, James M. (2015). Differences in Statistical Reasoning Abilities through Behavioral-Cognitive Combinations of Videos and Formative Assessments in Undergraduate Statistics Courses. *Electronic Theses and Dissertations*. Paper 2494. <http://dc.etsu.edu/etd/2494>
- Sahari, N., et al (2009). Student's Attitude towards Statistics Course. *Procedia Social and Behavioral Sciences* 18 (2011) 287–294. Retrieved from [www.sciencedirect.com/science/.../S1877042811011542](http://www.sciencedirect.com/science/.../S1877042811011542)
- Shan, S. & Ismail, Z. (2014). A technology-Based Statistical Reasoning Assessment Tool in Descriptive Statistics for Secondary School Students. *The Turkish Online Journal of Educational Technology* – January 2014, volume 13 issue 1. *The Turkish Online Journal of Educational Technology* 29
- Slootmaecker, K. (2015). A Barrier to Learning Statistics and to Acquiring Quantitative Skills. *Journal of Statistics Education*, Volume 23, Number 1
- Vanhoof, Sotos, et al (2006). Attitudes Toward Statistics and Their Relationship with Short- and Long-Term Exam Results. *Journal of Statistics Education* Volume 14, Number 3. [www.amstat.org/publications/jse/v14n3/vanhoof.html](http://www.amstat.org/publications/jse/v14n3/vanhoof.html)
- Tempelaar, D. (2006). A Structural Equation Model Analyzing the Relationship the Students' Statistical Reasoning Abilities, Their Attitudes toward statistics and learning approaches.
- Vanhoof, Sotos, et al (2006). Attitudes Toward Statistics and Their Relationship with Short- and Long-Term Exam Results. *Journal of Statistics Education* Volume 14, Number 3. [www.amstat.org/publications/jse/v14n3/vanhoof.html](http://www.amstat.org/publications/jse/v14n3/vanhoof.html)
- Wang, W., Wang, X. & Chen, G. (2009). Survey and Analysis of the Statistical Reasoning among High School Students in China and Dutch. *Journal of Mathematics Education*. Vol. 2, No. 1, pp.15-26.
- Sorden, S. (2012). The Cognitive Theory of Multimedia Learning. Retrieved from [http://sorden.com/portfolio/sorden\\_draft\\_multimedia2012.pdf](http://sorden.com/portfolio/sorden_draft_multimedia2012.pdf)

# ANALYSIS OF LET RESULTS OF THE TEACHER EDUCATION GRADUATES OF CAGAYAN STATE UNIVERSITY AT LAL-LO COVERING ACADEMIC YEARS 2010-2013

FERDINAND BULUSAN, MAEd

College of Teacher Education  
Cagayan State University  
Sta. Maria, Lal-lo, Cagayan Valley, Philippines  
[fgbulusan\\_gmail@yahoo.com](mailto:fgbulusan_gmail@yahoo.com)

## ABSTRACT

*Generally, this study assessed the performance of the Teacher Education Graduates in the Licensure Examination for Teachers (LET) from 2010-2013. Specifically, it determined the performance of both the BSEd and BEEd LET examiners as compared to the National Percentage of Passing and the performance of the BSEd LET examiners as compared to the BEEd LET examiners. It looked into the trend in the LET performance of graduates in terms of percentage of passing for BSEd and BEEd first timers and repeaters from 2010-2013. Data were taken from the Philippine Regulation Commission (PRC) website on LET results from September 2010 to March 2013. Both the first timers and repeaters in the BSEd program performed higher than the national passing percentage with an average difference of 22.27 percent. Meanwhile, the BEEd LET takers (first timers) performed best in the September 2012 exam; however, the repeaters performed lower. Also, BSEd (60.28) LET takers performed better than the BEEd (54.21 percent) takers. The trend in the performance of graduates in the last two exams for both first timers and repeaters is better than the first three exams. It is concluded that both the BSEd and BEEd LET taker performed higher than the national passing rate; the first timers performed far better than the repeaters. Moreover, the BSEd LET examiners performed better than the BEEd LET examiners in all exams considered, Finally, the percentage of passing for both programs for first timers and repeaters slightly increased in the last two examinations.*

**Keywords:** Education, Licensure Exam for Teachers, Teacher Education, College Graduates, Analysis of Licensure Exam

## I. Introduction

Enrolment in the College of Teacher education (CTE) gradually decreased few years ago due to the increasing demand of manpower in the commercial and industrial world. More graduates from the Basic Education preferred

to enroll in courses like Information Technology and Hospitality Industry Management which are relevant to the needs of industries and businesses both here and abroad. But the curriculum reforms in the Department of Education particularly the introduction of kindergarten to senior high school basic education, which increases the number of years in secondary education, has enticed secondary school graduates to pursue teacher education courses; hence, an increase again in enrolment. By 2016, when two more years (Senior High School) of secondary education shall have been completely implemented, more teachers will be needed to man the implementation of the said program. Teacher Education institutions are therefore

encouraged to strengthen their programs to participate also in the call for quality education. Akin to this, there is a need to assess the performance of education graduates in the LET as one measure to ensure quality education in the tertiary institutions for they are the producers of human resources of the basic education institutions.

Generally, the study assessed the performance of Teacher Education graduates in the Licensure Examination for Teachers (LET) from 2010-2013. Specifically, it sought to analyze the performance of the Bachelor of Secondary Education (BSEd) and Bachelor of Elementary Education (BEEd) graduates or LET takers as compared to the national percentage of passing for both first timers and repeaters; the overall performance of LET takers as compared to the national percentage of passing; the performance of the BSEd LET takers compared to the



national percentage of passing; the performance of the BSEd LET takers compared to the BEEd LET takers for both first timers and repeaters; and to determine the trend in the LET performance in terms of percentage of passing for both BSEd and BEEd first timers and repeaters.

## II. Methodology

Data were taken from the Philippine Regulation Commission (PRC) website on LET results from September 2010-March 2013. Results of March and September exams were all considered in the analysis. This research used a trend analysis tool.

## III. Results and discussion

### A. BSEd Results

Table 1 shows the results for the BSEd LET takers (first timers). Result indicates that the percentage of passing of the first timers in all the exams is higher than the national percentage with an average difference of 27.22%. The latest exam appears as the highest result where only one among the takers did not make it. Despite the longer exam for the BSEd, results reveal that the takers performed well because the percentage of passing is higher than the national passing rate.

The success is highly attributed to the conduct of course audit in the curriculum of the first time takers of LET. The course audit is a review scheme that is embedded in the institutionally crafted curriculum. Moreover, the selective retention, through the use of screening test administered before they had entered second year, also aided in the success of the first time takers. Immediately after their graduation, these students were encouraged to attend the college summer LET review packaged with LET simulated questions and test-wisness mentoring.

### B. LET Results of Repeaters

In Table 2, LET results of repeaters reveal that the repeaters' performance is very unsatisfactory. It was only in the March 2013 examination where the perfor-

Table 1. BSEd LET results (first timers).

Date	No. of Takers	No. of Passers	Percentage of Passing	National Percentage of Passing	Difference
Sept. 2010	8	4	50	25.86	24.14
Sept. 2011	19	10	52.03	31.45	20.58
March 2012	4	2	50	24.85	25.15
Sept. 2012	22	14	63.64	43.50	20.14
March 2013	7	6	85.71	39.61	46.10
Total/Average	60	28	60.28	33.05	27.22

mance of repeaters is higher than the national passing rate. This is because the repeaters graduated several years before taking the exam for the second time or

third time around and had no refresher courses or had not attended any review class before taking the exam again.

### C. Overall Performance of BSEd

Table 3 presents the overall performance of the BSEd LET takers in the last three years. Additionally, it shows that despite of the very low result of the

Table 2. BSEd LET results (repeaters).

Date	No. of Takers	No. of Passers	Percentage of Passing	National Perc. of Passing	Diff.
Sept. 2010	7	0	0	25.86	-25.86
Sept. 2011	6	0	0	31.45	-31.45
March 2012	7	1	14.29	24.85	-10.56
Sept. 2012	12	2	16.67	43.50	-26.83
March 2013	12	8	66.67	39.61	27.06
Total/Average	44	11	19.526	33.054	

repeaters, the overall performance in the exams is still higher than the national percentage of passing (73.68 against 39.61).

### D. Performance of BEEd first time takers.

For the BEEd, table 4 shows the LET results of the first timers. It can be gleaned on the table that like in

Table 3. BSEd overall performance.

Date	No. of Takers	No. of Passers	Percentage of Passing	National Percentage of Passing	Difference
Sept. 2010	50.00	0	26.67	25.86	0.81
Sept. 2011	52.03	0	40.00	31.45	8.55
March 2012	50.00	14.29	27.27	43.50	3.56
Sept. 2012	63.64	16.67	47.06	43.50	3.56
March 2013	85.71	66.67	73.68	39.61	34.07

the BSEd, the BEEd LET takers also garnered a higher percentage of passing in all the exams as compared to the national percentage of passing. Results reveal that they performed best in September 2012 exam with only one among the takers (9 against 8) failed.

Still, the conception and implementation of one semester course audit scheme, selective retention mechanism, and the conduct of summer LET review of the College are the primordial attributions to their success.

Table 4. BEEd LET results (first timers).

Date	No. of Takers	No. of Passers	Percentage of Passing	National Percentage of Passing	Difference
Sept. 2010	15	6	40	19.58	20.42
Sept. 2011	10	3	30	22.68	7.32
March 2012	13	7	53.85	42.26	11.39
Sept. 2012	9	8	88.89	49.29	39.60
March 2013	12	7	58.33	27.78	30.55
Total/Average	59	31	54.21	32.36	21.85

*Overall Performance of BEEd LET Repeaters*

The performance of the BEEd repeaters is not satisfactory because in all the exams, the result was lower than the national percentage of passing, except for the September 2012 exam. Repeating the exam long after graduation without attending refresher courses or review classes reduces their chance to pass the exam. More so, items in LET do constantly change to cope with the new trends and issues in pedagogy.

Table 5. BEEd LET results (repeaters).

Date	No. of Takers	No. of Passers	Perc. of Passing	National Perc. Passing	Diff.
Sept. 2010	12	0	0	19.58	-
Sept. 2011	22	2	9.09	22.68	-
March 2012	1	0	0	42.46	-
Sept. 2012	20	11	55.00	49.29	5.71
March 2013	4	1	25.00	27.78	-2.78
Total/Average	59	12	17.82	32.36	

*F. Three-year Overall Performance of BEEd and BSEd LET Takers*

The overall performance of the BEEd LET takers in the last three years indicates that only in September 2011, the percentage of passing was lower than the national passing rate (22.68 against 19.54). The result of the repeaters immensely affected the overall results.

Results also disclose that the BSEd performed better in the licensure examination as revealed in the average percentage of passing of 60.28% as compared to an average of 54.21% of the BEEd. Similarly for the repeaters, the BSEd average percentage of passing of 19.52% is higher than the BEEd, with only an average of 17.82%.

In anent to the trend in the performance of graduates in the LET, results expose that their performances in the last two exams for both first timers and repeaters are better than the first three exams. If the observation would continue in the next few years, it could be a determinant of an improving quality of instruction. Intervening measures of the CTE, like conducting course audit and colloquium, selective retention through screening test, and summer LET

review, are sound indications of success.

IV. Conclusion

Both the BSEd and BEEd first timer LET takers had a higher percentage of passing as compared to the national passing rate; the first timers performed far better than the repeaters; BSEd Let takers performed better than the BEEd Let takers in all the exams considered; and the percentage of passing in both programs and for both first timers and repeaters slightly increased in the last two exams.

Also, repeaters who have long graduated in their undergraduate programs and who have just taken the LET recently may likely fail the exam again due to the continuing change of items in the LET vis-à-vis the latest trends and issues in pedagogy.

Recommendations

To sustain the increasing percentage of the LET institutional passing rate versus the national passing rate, the college is urged to continue the intervening measures like the conduct of a one-semester continuum or course audit, the selective retention scheme with maintaining general average of 85 before teacher education students second year, and the conduct of the summer LET review with simulated LET questions and mentoring.

Since attendance to a LET review class should be a requirement for LET takers, the college may craft a review scheme specifically for prospect repeaters. LET readiness assessment should also be conducted to both prospect repeaters and first time takers to identify those who would most likely fail. After the identification process, the college may use another intervention to ensure the passing of those who are not yet ready for the LET.

As for the curriculum, the college may upgrade the both the BEEd and BSEd curricula by stressing topics that are perennial ambits in LET.

Finally, benchmarking with other universities regarding good and effective practices in sustaining LET passing rate may be done by the college to increase its perspective on

## References

- Aquino, G. (2004). *Effective teaching* (3rd ed). Mandaluyong City: National Bookstore.
- Arce, Sheilamarie E., Josephine L. Belen (2011). The Pre-Board Examination Part of the In-house Reviews as predictor of LET Results. *Manuel S. Enverga University Foundation*. Vol.13,No.1.
- Barrientos, Eva Maria Corazon S., Dominador S. Garin, Ph.D. (2008). Readiness and Competencies of Students in Teacher Education Institutions of the Cordillera Administrative Region. *Research Journal*, Vol.16.
- Bilbao, P. (2006). *The Teaching Profession*. Metro Manila: Lorimar Teaching Co.
- Brigman, Greg, Chari Campbell, Ph.D. (2007). *Helping Students Improve Academic Achievement and School Success Behavior*. Florida Atlantic University. Boca, Raton. Vol.7,No.2.
- Davis, B.G. (1999). Quizzes, tests, and exams. Retrieved August 1, 2008 from: <http://honolulu.hawaii.edu/intranet/committees/FacDevCom/guidebk/teachtip/quizzes.htm>.
- Espino, Nely G., Dr. Ma. Fe. V. Roman, and Dr. Glenda C. Magno (2011). *The Academic Performance, Licensure Examination for Teachers Results from 2004- 2008 and Work Performance of BSED Graduates: An Analysis*. Bataan Peninsula State University. Balanga City, Bataan.

# COMPUTER-AIDED LANGUAGE LEARNING IN THE EYES OF THE INDIGENOUS PEOPLE COLLEGE STUDENTS

Edwin L. Nebria, Ed.D.  
College Professor 1 / Chair - Language Discipline  
University of Mindanao, Bolton Street, Davao City Philippines  
edwin\_nebria@yahoo.com

## ABSTRACT

*Being proficient in the use of the English language is a must to be globally competitive. However, studies show that students have difficulty in using English both in speaking and writing as cited by Alvior, (2007). With the consistent growth in ethnic diversity in schools, teachers have to learn at the university level or in professional development course how to educate ethnically diverse students. This prompted the University of Mindanao to employ Computer Assisted Language Learning through Dynamic Education Software. This study aimed to document Indigenous People students' experiences in Computer-Aided Language Learning, and to evaluate its effects to their language proficiency after the exposure and how students interact and adjust themselves in learning English with the aid of the multimedia computers in the second semester of School Year 2013 – 2014. The study employed a one-shot case experimental design with qualitative explanatory notes research approach, specifically the pre-test - post-test design or before-after survey, with the weighted mean, and t-test as statistical tools, and the primary data taken from Dyned pre-placement and post-placement tests results and in-depth interview. Results revealed that the IP college students showed an increase of their exit placement after exposure to DynEd software, and IP students considered their CALL experience as nervousness at the onset as they learn how to navigate and use the computers. Evidently, as their confidence and skills increased, they henceforth enjoyed their computer-aided language learning via DynEd. This means that utilizing CALL can improve the English proficiency of the IP students. This supports the theory of Little, David (1996) states that "Freedom to learn and compulsion to interact promotes the learner's autonomy through the use of technologies." This further supports the statement of Knowles (2004) that synchronized activation of the auditory, phonological and visual systems in the brain are important in the development of the macro skills.*

**Keywords-component; Indigenous People; Computer-Aided Language Learning; Dynamic Education; English Language Proficiency.**

## Introduction

To be globally competitive, one must be proficient in the English language. However, studies show that students have difficulty in using English. In the study of Tippeconnic and Faircloth (2010) as cited by Napil (2014) there are 370 million approximately of indigenous people in the world.

With the consistent growth in ethnic diversity in schools, teachers have to learn at the university level or in professional development course how to educate ethnically diverse students. Glimpse (2007) opined that since education is the process of gaining information about the surrounding world, it is a must for the educators to create an effort that promotes students' welfare. Accordingly, schools must improve facilities and promote enhancement programs in order to maximize learning of the students (Klent, 2001). These programs may include computer aided instructions.

Moreover, as cited by Muaña (2011) in the study of Napil (2014), that beyond half of the approximated number of young indigenous students in Western Australia were rated by their teachers as slow learners in the general academic performance. Further, they stated that there is a big disparity in the general academic performance of indigenous and non-indigenous students. The incidence of low academic performance is notably higher among indigenous students compared to non-indigenous students.

Despite the recent reports that show Filipinos getting ahead in speaking English, there are still thousands who are struggling communicators. This fact pushed the different Philippine Universities in seeking for an efficient way of improving the proficiency of Filipinos in the English Language especially in native tribes.

Globally, Knowles (2004) said, the use of the computer-aided instructions for the English language has gained popularity in the USA, Europe, and Asia. Moreover, he said that this helps achieve one of the goals of education, that is, to be proficient in the use of the English language so that students may become globally competitive. This is done because research shows that students have difficulty in using the English both in conversation and writing as cited by Alvior (2007). Moreover, Knowles stressed that students' academic preparation was inadequate and did not afford them the opportunity to engage in conversation in a language other than their own. Most schools in the USA are utilizing Computer-Assisted Modules in order to improve communication skills of students (De George, 2000).

Nationally, Filipinos' self-assessed proficiency in the English language has declined over the past twelve years, according to the March 2006 Social Weather Survey, compared to earlier SWS surveys in December 1993 and September 2000. The use of the computer-aided training and instructions are increasingly visible in different schools and universities in the Philippines. This becomes a priority for school administrators so that the developments of the communicative skills of their clients are maximized.

Regionally, several schools in region XI are using the Computer-Aided Instructions in order to improve students' macro-skills. The University of Mindanao is employing computer aided language learning since School Year 2006 and recently the Davao Maritime School of Davao also adapting (CALL) via Dynamic Education Software (DynEd) for developing communication skills / proficiency particularly in the English language of the students.

Locally, in Davao City, the students of University of Mindanao are observed to have no firm hold of their writing and speaking skills in English (Alderite, 2003). Hence, the University of Mindanao Administration has been supportive in all the projects launched by the Language department to arrest the problem. In fact, the Administration provided the students with computers to be used in their 10 hour exposures in computer-aided language instruction via DynEd (Dynamic Education) software as an embedded program for students enrolled in any English subject across colleges.

DynEd is in its full blast of operations as an embedded program of the language department of the University of Mindanao. However, a study must be conducted to find out if students' problem in English proficiency has been solved particularly in the group of IP (indigenous people) college students since they

are mostly from far-flung provinces and had no experience in using computer in actual scenario. Being new in the environment as college students, they even hesitate to communicate someone of different language particularly in the English.

Based on the observation of the researcher, DynEd for the Indigenous People is something new which is not easy to do with a lot of apprehensions seen in their facial expressions, with a lot of queries since they are still neophytes in their new journey as college students in the university. The IP students seem may encounter some difficulties or barriers in dealing with software. Hence, the researcher ought to find out how beneficial it is for the case of indigenous college students to develop their language proficiency and computer skills to be globally competitive through computer-aided language learning program.

#### Indigenous People (IP)

The Lumad is a group of indigenous peoples of the Southern Mindanao, Philippines. Lumad is a Cebuano term meaning 'native' or 'indigenous'. The term is short for "indigenous peoples".

Due to the impact and influence of information technology on society and education, computer-assisted language learning is becoming the trend in foreign language teaching. Computer-assisted language learning can reduce the anxiety of students and turns out to be a positive side of learning (Gates, 1997).

Computer-Aided Language Learning is an acronym for computer-assisted instruction, a type of educational program designed to serve as a teaching tool. It is related to the use of computers in teaching; others include computer-assisted learning, computer-augmented learning, computer-based learning, computer-based training, and computer-managed instruction, a diverse and rapidly expanding spectrum of computer technologies that assist the teaching and learning process.

According to the study of Bañados and Ripoll (1999), computer-aided language learning is of great advantage since this provides a human like dimension for positive and corrective feedback, giving the students the sense of belonging to a learning community, and helping them develop their self-confidence and

their language skills through individual practice, communication both through face-to-face and collaborative activities.

CALL helped basically the students on how to follow instructions given by the computer itself. It could develop listening skills and right pronunciation. Ducker (2009) as cited by Pacual (2012) has noted that the lack of literacy skills among indigenous student specifically in word recognition and reading comprehension are common problems and critical barrier in education

In a study conducted by Frigaard (2002), it was found out that the computer lab was a beneficial tool, benefiting some students more than others. Most students believed that the lab improved their Listening skills and made class more interesting.

DynEd's unique interactive program enables students to work at their own pace, with instant access to repetition and comprehension aids such as translation, on-screen text, glossary support, and mastery test. Students record their own voices and compare their recordings with the native speaker model provided in the courseware. It is designed to help acquire the target language in a natural but accelerated mode of learning.

The software exposure or trainings premised on the holistic and authentic approaches to learning and adopts student/participant – centered methodology. The content has been sequenced according to fundamental elements of English language skills. It offers a variety of activities and opportunities in understanding International English sounds, crucial grammar points and valuable language skills to be learned, and emphasized on practical use of language.

Alvior (2007) cited in her study that using computer-aided language learning could enhance the English Proficiency of the students in practicing and recording their voice whether hands-on or even just in mobile method of exposure to the DynEd software.

Based on the observation of the researcher, teaching DynEd is not easy for the teachers handling this program since the IP students are still neophytes in their new journey, they need to be taught about computer operations. The IP students encountered some unexpected difficulties or barriers due to lack of sufficient knowledge and computer skills, lack of experience, insufficient time, computer anxiety and lack of confidence, although all participants in the study had positive attitudes towards the use of technology and strong intrinsic motivation such as personal curiosity and interest, they still need to be taught in using computer aside from teaching language via

DynEd.

English Language Proficiency is a critical element in the process of becoming literate and all of the other public manifestations of human intelligence that enable a person to become more effective and efficient in all other areas especially in the non-English speaking countries where the medium of instruction at school in English (De George, 2000).

### Conceptual Framework

This study is anchored on the theory of Little, David (1996) states that “Freedom to learn and compulsion to interact: promoting learner autonomy through the use of technologies.” The theory has proven true by the concept of Knowles (2004) which states that synchronized stimulation of the auditory, phonological and visual systems in the mind are important in the development of listening, reading and speaking skills.

This theory is also supported by Castillo (2001) who explained that exposure of students to advances in technology clearly relates to the English proficiency achievement.

This theory is likewise supported by Chun and Brandl (1992), stated that the computer assisted in learning the language which is interactive is an attractive teaching tool. Furthermore, the theory has proven true by the concept of Klent (2001) that interactive media environment can help students find clear objectives, and clear instructions of what they are expected to do, to achieve their language learning goals for second language learning.

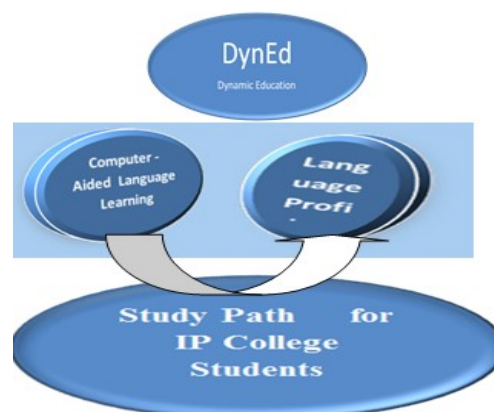

Figure 1: Schematic Diagram of the Study

The researcher, being a language professor for more than two decades, believes that embarking on this study would somehow give light about how beneficial computer-aided language learning used by the university for the students together with the (IP) Indigenous People to their academic performance. Thus, the researcher is challenge to investigate and thereby create an intervention program exclusively designed for them.

DynEd's exceptional collaborative package empowers students to work at their own pace, with prompt access to reiteration and understanding aids such as paraphrase, on-screen text, glossary support, and mastery test. Students record their personal voices and compare their recordings with the native speaker model provided in the courseware. A software intended to support students improve abilities in speaking, listening, reading, and writing, which was initiated in 1987 by the past administrator of the Language Institute of Japan (LIOJ), Lance Knowles with a team of engineers.

Moreover, there are numerous forms of questions in the Placement Test. New Dynamic English (NDE) is one of the courseware of the DynEd software, comes in eight modules. Each module divided five units. Some of these units are Names and Places, Jobs and Family, Planning Ahead, and life Choices. The language models in these units prepare students to communicate about their own lives and experiences in increasing detail as the course progresses.

The software exposure or trainings premised on the holistic and authentic approaches to learning and adopts student/participant – centered methodology. The content has been sequenced according to fundamental elements of the English language skills. It offers a variety of activities and opportunities in understanding International English sounds, crucial grammar points and valuable language skills to be learned, and emphasized on practical use of language.

This study aims to discover how Indigenous People college students regulate themselves in learning English with the help of multimedia computers and the collaboration between students and multimedia computers, for the researcher to figure out whether the breakthrough on computer-aided learning really affects the language proficiency of IP college students.

## STATEMENT OF THE PURPOSE

This study aimed to document IP students' experiences in Computer-Aided Language Learning and to evaluate its effects to their language proficiency in the second semester of School Year 2013 – 2014. Specifically, the study tried to answer the following questions:

1. What is the profile of the IP college students when grouped into,

1.1 gender;

1.2 course; and

1.3 tribe?

2. What are the pre-test and post-test mean scores of the IP students in DynEd Placement test?
3. Is there a significant pre – post mean gain scores of the IP students in DynEd Placement test when grouped into tribe?
4. Is there a significant difference in the mean gain scores among IP students in DynEd Placement test when grouped according to tribe?
5. What are the experiences of the IP college students in computer-aided language learning via DynEd?
6. Based on the findings, what enhancement program can be proposed for the IP college students?

## Hypotheses

The null hypotheses below will be tested at 0.5 level of significance

1. There is no significant difference in mean gain scores of the pre and posttest of the IP college students.
2. There is no significant difference in mean gain scores of the pre and posttest of the IP college students when grouped according to tribe.

## III RESEARCH METHODOLOGY AND PROCEDURES

This chapter presents the research method, participants, environment, research instrument, data gathering procedure in the conduct of the study and the statistical treatment to be used.

### Research Method

The study is dominantly one-shot case experimental design with qualitative explanatory notes research approach specifically the pre-test-post-test and in-depth survey design. The result of the two tests was compared to determine if there's a change in the students mean scores particularly in IP students. According to Merriam (1998), qualitative research will be conducted to gain insight or understand the experiences of the participants.

The “Study Path” and the flow of the DynEd sessions for the students; First, was the creation of the classes and enrollment, and during first day of the specific schedule, the students were inducted with DynEd courseware and given the placement test which was considered as the pretest or pre-placement test. Then after taking the placement test, the students underwent with the recommended courseware for the sessions and extension activity, finally after the 10 hours exposure with the program they took the last placement or the post-test placement.

Beforehand, orientation was administered, then the IP college students took the placement test, supposedly, the computer was the one to decide what lessons they need to take based on their pre-placement results according to the DynEd placement level, but in-order to avoid bias for the students who got high or low placement level, there was a unison or respective guide for them to work-on no matter what level they had in their pre-placement test, this is called “study path”. The students took the New Dynamic English, one of the DynEd coursewares which is considered as the foundation or basic in grammar, composed of eight modules, but the students were required to accomplish the first three modules only for the first year across college.

In accomplishing the study path, the student has to answer the lessons in sequence with 30% completion rate in-order to open the mastery test automatically. For the review exercises, the students need to answer two items in dictation, and nine items in fill-ins activity, five sets in speech practice, and for video interaction, the students need only to answer one activity with SRV or Speech Record Video.

After the completion of each activity with thirty percent completion rate, the students can take the nine mastery test out of the three modules, then exit or post-placement test must be taken. Extraction of students records through the records manager of the DynEd software.

#### Participants

The participants of the study were the identified 73 IP college students in the University of Mindanao from eight different tribes as shown on the table. Among the participants, most of the number were coming from Manobo tribe generally coming from the remote area of Davao city and towns nearby followed by the Mandaya tribes mostly coming from the oriental part of Davao, then Bagobo and Ata tribes who have almost the same in number of participants. Bagobo tribes are coming from south Davao area and the Ata are from the mountainous part of Davao city. The rests of the participants with the least in number were from the tribes of B’laan, Matigsalog, and T’boli. The participants were the identified IP college students of the University of Mindanao for the School Year 2013 – 2014.

Shown in Table 1 is the distribution of respondents classified by tribes. Involved in the study are 73 IP respondents with 9 ATA respondents, 10 Bagobo, 7

B’laan, 3 Kalagan, 14 Mandaya, 22 Manobo, and the Matigsalog and T’boli is 4 respondents. Majority of the

**Table 1. Distribution of IP participants**

TRIBES	Participants
Ata	9
Bagobo	10
B’laan	7
Kalagan	3
Mandaya	14
Manobo	22
Matigsalog	4
T’boli	4
<b>Total</b>	<b>73</b>

participants are coming from the Manobo tribe, this is an evident that even the Manobo tribe nowadays valuing education, for them to compete to a very competitive world, followed by the Mandaya, then Bagobo who opted to be in the city rather than staying in the mountain just working in the field. This implies that indigenous people residing near the city of Davao like the Manobo tribe chose to enroll in the University of Mindanao to avail the scholarships extended by the university to every qualified indigenous people students. This is followed by the Mandaya tribe who hails from the oriental part of Davao province, and the same with the Bagobo tribe who are from the south Davao province. The rest of the participants are from Cotabato city, South Cotabato, and from the new province of Davao which is Davao Occidental Province who opted to continue their tertiary education in the University of Mindanao.

#### Environment

The students were attended their DynEd sessions according to their given schedules at the IEL (Interactive English Laboratory) both in UM Bolton and UM Matina campus. The students started with the orientation regarding to the rules and regulations in using the laboratory equipment, and the study path to work on during the duration of DynEd sessions, then took the pre-placement test and work according to their pace with the help of the study path as guide, after



working with the lessons provided in the study path, then took the post placement test.

The study was conducted in the University of Mindanao, the biggest university in Region 11 where a substantial number of IP students were enrolled. These IP students were attracted to enroll in the university due to its proven quality education recognition. To name a few, the university was awarded as the only ISO, Autonomous Status, Category A+ status, 1 Center of Excellence (College of Teacher Education), 4 Centers of Development, Level IV Accredited Status, Level III Accredited Status. In addition, the university supports the constitutional mandate of Commission on Higher Education in providing equitable access to education regardless of socio-cultural backgrounds. In fact, the university convened all Indigenous People (IP) students into a recognized university student organization-the PAGLAUM to smoothly transition them in the students' life full of struggles and insecurities.

The main instruments were based from in-depth interview and the results of the Pre and Post placement tests from DynEd (Dynamics Education) of the IP college students. The Placement tests were Research Instruments taken in the DynEd laboratory of the University of Mindanao both Matina and Bolton campus. The pre-test and post-test placement scores of the students were used in analyzing the significance of the program with the IP college students.

The Placement Test is a computer adaptive, variable length test. It responds and adjusts to the student's performance.

In-Depth Interview Guide. To determine the perceptions, and experiences of the Indigenous People (IP) college students regarding computer-aided language learning via (DynEd).

#### Data Gathering Procedure

Data gathering was conducted during summer of the School Year 2013-2014. As the first step, the researcher sent a letter to the President of the university and to the adviser of PAGLAUM to seek permission to conduct the study. The same letter was sent to the laboratory custodians for the access of the IP students' records from the records manager of the software in three DynEd laboratories. After the approval, the researcher then personally administer the questionnaires and interviewed the IP students during one of their monthly meetings. The administration of the questionnaires was so timely in the sense that it was during their monthly meeting, the researcher was able to gather IP students. The data were retrieved, classified according to its gender, course and tribe. It was tallied, tabulated, analyzed, and interpreted confidentially and accordingly.

For the qualitative part of the study not all respondents answered the questions, because out of 73 enlisted and recognized IP members of the PAGLAUM

organization, only around 30 percent, a total of 22 IP students were enrolled the during Summer 2014.

Retrieval of Data. The Students' result of the pre-test and post-test scores/level of the UM IP college students were extracted from the records manager of the said DynEd software as computer-aided language learning tool.

Analysis of Data. Analyzed the data using appropriate statistical tools.

#### Data Analysis Tools

The following statistical treatments were used to interpret the data gathered.

Percentage. This is the ratio of the part with respect to the whole. Assumption is based on the concept of dividing the whole into one hundred equal parts and each part represents a percent. In this study, it was used to present the ratio of the respondents with respect to the total number of students enrolled in the DYNED programs.

Mean. This is the ratio of the total score and the number of cases involved in the process. In this study, this was used to present the pre-test and post-test scores of the UM IP college students.

T – test. This is the test of differences of the means whether they are dependent or independent. In this study, this was used in order to test if there are significant differences in the mean scores of the UM IP college students. In addition, the difference of the pre-test and the posttest scores of the UM IP students will also be studied and verified.

Anova. One way Anova was used to answer sub-problem 2 to determine the difference in the Pre-test and Post-test of respondents when grouped by tribe, by gender, and by course. This was also used to determine the impact to the independent variables with the dependent variable. A statistical analysis tool that separates the total variability found within a data set into two components: random and systematic factors.

#### IV PRESENTATION, ANALYSIS, AND INTERPRETATION

Presented in this section are the data obtained from the IP students as the respondents of the study. The order of the discussions is based on the problems stated in the previous chapter. The major topics discussed in

this study include profiles of the respondents; pre-test and post-test scores of the IP students, pretest and posttest scores across gender, pretest and post-test scores across college, pretest and posttest scores across tribes, difference on the pre-post mean gain scores of the IP students across tribes, difference between gender, difference across college, difference across tribes, and difference on pre-post mean gain scores of the IP students across tribes.

#### Profiles of IP Students

Presented in Table 2 are the profiles of the respondents classified according to gender, course and tribe. Data show that majority of the IP students involved in the study are female respondents. This indicates that most of the female IP individuals are more interested to pursue with the tertiary education compared to male group. In terms of course, data show a greater number of students enrolled in Teacher Education program and this would mean that the said students are more attracted with the teaching profession. This may indicate that most of the IP respondents are interested to spend their lives to the teaching profession. It is evident in the table that when classified by tribe, most of the respondents are Manobo.

Table 2. Profile of the IP College Students

Variable	Category	Frequency	Percentage
Gender	Male	23	31.51
	Female	50	68.41
Course	Accountancy	3	4.11
	Bachelor of Arts	9	12.33
	Business Administration	3	4.11
	Criminology	6	8.22
	Hospitality Education	5	6.85
	Nursing	1	1.37
	Teacher's Education	37	50.68
	Information Technology	1	1.37
	Social Work	5	6.85
	Tourism	3	4.11

Tribe	Ata	9	12.33
	Bagobo	10	13.70
	B'laan	7	9.59
	Calagan	3	4.11
	Mandaya	14	19.18
	Manobo	22	30.14
	Matigsalug	4	5.48
	T'boli	4	5.48

Note: n = 73

It can also be gleaned from the table that out of seventy-three participants, in terms of course taken, majority of the respondents were taking up Bachelor of Science in Education. This was due to the reason that greater job opportunity awaits in the community where the respondents belong. Considers of taking up this course entails less financial support. With the number of IP college students implies that even the indigenous people from the remote area are now very particular in education.

#### Pre-Test and Posttest Scores of the IP Students

Presented in Table 3, the pre-test mean score of the respondents is 0.7 which is interpreted as beginner level. Their post-test mean score is 1.0 which means elementary level.

Table 3. Pre-test and Post-test Scores of the IP Students

It appears in the table 3 that the IP students have increased mean score in the post-test which is an indicative of an improved performance ranging from

	Mean	SD	Interpretation
Pre-test Score	0.7	.52347	Beginner level
Post-test Score	1.0	.67971	Elementary level

Note: n = 73

beginner level to elementary level. This means that the respondents before they were exposed to the dynamic education were not able to communicate in English, even about time and numbers.

Some of the respondents may have prior knowledge of basic English. After their exposure to the intervention, the students' level became

elementary level which means that they can answer simple questions; however, these respondents may have difficulty in life history or future plans since their skill is limited to basic patterns only.

It implies further that the pre-test and post-test scores of IP students obtained a mean difference of 0.3. This result is also supported by Chun and Brandl (1992) who stated that the interactive and multimedia capabilities of the computer make it an attractive teaching/learning tool. They said computers can provide immediate feedback to students and students can work at an individualized pace. Further, this is also supported by the concept of Klent (2001) that interactive media environment can help learners find explicit objectives, and clear instructions of what they are expected to do to achieve their language learning goals for foreign/second language learning. In agreement Castillo (2001) explained that exposure of students to advances in technology clearly relates to English proficiency achievement.

#### Pre-test and Post Test Scores Across Gender

Presented in Table 4 are the pre-test and post-test scores across gender.

Table 4. Pre-test and Post-test Scores in Language Test Scores across Gender

It can be gleaned in the table, that the pre-

Gender	Pre-test	Interpretation	Post-test	Interpretation
Male	0.7	Beginner	1.0	Elem. Level
Female	0.7	Beginner	1.0	Elem. Level

test mean score across gender considered as beginner according to the DynEd placement test level. It means that the participants before the exposures having a little knowledge in basic grammar and just able to answer the 5 WH questions, while the post-test mean score for both gender was slightly improved which described as elementary level of the same test. Data indicate an increase in the post-test performance of students after their exposure to the dynamic education. This implies that the experience with the dynamic education has contributed a little to the students' mean rating. This further implies that students' mean increase only shows little improvement in their language skills which corresponds to ability of using short sentence only to answer simple questions. Data further indicate that both male and female respondents have the same mean ratings in pre-test and post-

test evaluations. This implies that male and female are equally capable of performing elementary level of English language skills after their exposure to the dynamic education. This indicates that there is an improvement from Beginner to Elementary level of the post-test according to the DynEd placement test. This further implies that the conduct of computer assisted learning was helpful in the enhancement of the respondents' knowledge and skills on basic English concepts. These findings corroborate the report of Singhal (1997) who stressed microcomputers and quality computer assisted language learning enhances vocabulary, grammar and writing as well as reading.

#### Pre-test and Post-Test Scores of Students across College

Shown in Table 5 are the pre and post-tests scores across colleges.

Shown in the table that for accountancy students, their scores in pre-test and post-test are described false beginner with mean scores of zero for the pre-test and 0.2 for the post-test, which would mean that the said

College N	Pre-test	Interpretation	Post-test	Interpretation
CAE 3	0.0	False Beginner	0.2	False Beginn
CAS 9	0.8	Beginner	1.1	Elem. Leve
CBA 3	0.7	Beginner	1.2	Elem. Leve
CCJE 6	0.7	Beginner	1.3	Elem. Leve
CHE 5	0.9	Beginner	0.9	Beginner
CNE 1	1.0	Elem. Level	1.0	Elem. Leve
CTE 37	0.7	Beginner	1.0	Elem. Leve
IT 1	0.7	Beginner	0.5	Beginner
S W 5	0.6	Beginner	0.7	Beginner
Tourism 1	0.7	Beginner	1.0	Elem. Leve

respondents was not able to listen, read and analyzed properly the lesson. The CBA students have indicated a pre-test rating of 0.8 and a post-test rating of 1.1

which means improved skills of students after having exposed to dynamic education. The CAS, CBA and CCJE students were beginners as based on their pre-test mean score, but their performance have reached to 1.1, 1.2 and 1.3 respectively with elementary level. Data further show that the CHE students have the same rating both in pre-test and post-test evaluations.

This is an indicative that the dynamic education has not helped the CHE students in terms of language development. Further, the CNE students demonstrate the same ratings of 1.0 in their pre-post evaluations. This entails no difference in the respondents' knowledge and skills even if they were exposed to dynamic education. This means that the said intervention is considered ineffective for the CNE students. The CTE students have improvement in their ratings from 0.7 pre-test score to 1.0 post-test score. This means that the CTE students have improve a little which is from beginner level to elementary level. There is a little increase in the performance of CTE respondents after having exposed the dynamic education.

The IT and social work students were beginner during pre-test and are still beginner after their exposure to dynamic education. This is an indicative that the said students have not learned anything from the intervention on dynamic education. On the other hand, the CAS, CBA and CCJE students were beginners as based on their pre-test mean score, but their performance have reached to 1.1, 1.2 and 1.3 respectively with elementary level. This implies that these students are unable to communicate using the English language. Also shown in the table, the tourism students indicate mean increase in their post-test mean scores, showing a little bit favorable language skills after their dynamic education exposure. This is an evident that DynEd would really help in increasing the knowledge of the students particularly in English based on its principles of increasing two points is good enough for a beginner.

#### Pre-Test and Post-Test Scores across Tribes

Shown in Table 5 are the pre-test and post-test scores of students coming from different tribes.

Table 6. Pre-test and Post-test Scores across Tribes

Tribe (N)	Pre-test	Interpretation	Post-test	Interpretation
Ata 9	0.5	Beginner	0.5	Beginner
Bagobo 10	0.5	Beginner	0.8	Beginner
Blaan 7	0.7	Beginner	1.1	Elem. Level
Kalagan 3	0.6	Beginner	0.7	Beginner

Mandaya 14	1.3	Elem. Level	1.7	Adv. Elem level
Manobo 22	0.6	Beginner	0.8	Beginner
Matigsalug 4	0.7	Beginner	0.8	Beginner
Tboli 4	0.6	Beginner	0.6	Beginner

Note: n = 73

It can also be gleaned from the table that out of seventy-three participants, in terms of course taken, majority of the respondents were taking up Bachelor of Science in Education. This was due to the reason that greater job opportunity awaits in the community where the respondents belong. Considers of taking up this course entails less financial support. With the number of IP college students implies that even the indigenous people from the remote area are now very particular in education.

#### Pre-Test and Posttest Scores of the IP Students

Presented in Table 3, the pre-test mean score of the respondents is 0.7 which is interpreted as beginner level. Their post-test mean score is 1.0 which means elementary level.

Table 3. Pre-test and Post-test Scores of the IP Students

	Mean	SD	Interpretation
Pre-test Score	0.7	.52347	Beginner level
Post-test Score	1.0	.67971	Elementary level

Note: n = 73

It appears in the table 3 that the IP students have increased mean score in the post-test which is an indicative of an improved performance ranging from beginner level to elementary level. This means that the respondents before they were exposed to the dynamic education were not able to communicate in English, even about time and numbers. Some of the respondents may have prior knowledge of basic English. After their exposure to the intervention, the students' level became elementary level which means that they can answer simple questions; however, these respondents may have difficulty in life history or future plans since their skill is limited to basic patterns only.

It implies further that the pre-test and post-test scores of IP students obtained a mean difference of 0.3. This result is also supported by Chun and Brandl (1992) who stated that the interactive and multimedia capabilities of the computer make it an attractive teaching/learning tool. They said computers can provide immediate feedback to students and students can work at an individualized pace. Further, this is also supported by the concept of Klent (2001) that interactive media environment can help learners find explicit objectives, and clear instructions of what they are expected to do to achieve their language learning goals for foreign/second language learning. In agreement Castillo (2001) explained that exposure of students to advances in technology clearly relates to English proficiency achievement.

#### Pre-test and Post Test Scores Across Gender

Presented in Table 4 are the pre-test and post-test scores across gender.

Table 4. Pre-test and Post-test Scores in Language Test Scores across Gender

Gender	Pre-test	Interpretation	Post-test	Interpretation
Male	0.7	Beginner	1.0	Elem. Level
Female	0.7	Beginner	1.0	Elem. Level

It can be gleaned in the table, that the pre-test mean score across gender considered as beginner according to the DynEd placement test level. It means that the participants before the exposures having a little knowledge in basic grammar and just able to answer the 5 WH questions, while the post-test mean score for both gender was slightly improved which described as elementary level of the same test. Data indicate an increase in the post-test performance of students after their exposure to the dynamic education. This implies that the experience with the dynamic education has contributed a little to the students' mean rating. This further implies that students' mean increase only shows little improvement in their language skills which corresponds to ability of using short sentence only to answer simple questions. Data further indicate that both male and female respondents have the same mean ratings in pre-test and post-test evaluations. This implies that male and female are equally capable of performing elementary level of English language skills after their exposure to the dynamic education. This indicates that there is an improvement from Beginner to Elementary level of the post-test according to the DynEd placement test.

This further implies that the conduct of computer assisted learning was helpful in the enhancement of the respondents' knowledge and skills on basic English concepts. These findings corroborate the report of Singhal (1997) who stressed microcomputers and quality computer assisted language learning enhances vocabulary, grammar and writing as well as reading.

#### Pre-test and Post-Test Scores of Students across College

Shown in Table 5 are the pre and post-tests scores across colleges.

College N	Pre-test	Interpretation	Post-test	Interpretation
CAE 3	0.0	False Beginner	0.2	False Beginn
CAS 9	0.8	Beginner	1.1	Elem. Leve
CBA 3	0.7	Beginner	1.2	Elem. Leve
CCJE 6	0.7	Beginner	1.3	Elem. Leve
CHE 5	0.9	Beginner	0.9	Beginner
CNE 1	1.0	Elem. Level	1.0	Elem. Leve
CTE 37	0.7	Beginner	1.0	Elem. Leve
IT 1	0.7	Beginner	0.5	Beginner
S W 5	0.6	Beginner	0.7	Beginner
Tourism 1	0.7	Beginner	1.0	Elem. Leve

Shown in the table that for accountancy students, their scores in pre-test and post-test are described false beginner with mean scores of zero for the pre-test and 0.2 for the post-test, which would mean that the said respondents was not able to listen, read and analyzed properly the lesson. The CBA students have indicated a pre-test rating of 0.8 and a post-test rating of 1.1 which means improved skills of students after having exposed to dynamic education. The CAS, CBA and CCJE students were beginners as based on their pre-test mean score, but their performance have reached to 1.1, 1.2 and 1.3 respectively with elementary level. Data further show that the CHE students have the

same rating both in pre-test and post-test evaluations.

This is an indicative that the dynamic education has not helped the CHE students in terms of language development. Further, the CNE students demonstrate the same ratings of 1.0 in their pre-post evaluations. This entails no difference in the respondents' knowledge and skills even if they were exposed to dynamic education. This means that the said intervention is considered ineffective for the CNE students. The CTE students have improvement in their ratings from 0.7 pre-test score to 1.0 post-test score. This means that the CTE students have improve a little which is from beginner level to elementary level. There is a little increase in the performance of CTE respondents after having exposed the dynamic education.

The IT and social work students were beginner during pre-test and are still beginner after their exposure to dynamic education. This is an indicative that the said students have not learned anything from the intervention on dynamic education. On the other hand, the CAS, CBA and CCJE students were beginners as based on their pre-test mean score, but their performance have reached to 1.1, 1.2 and 1.3 respectively with elementary level. This implies that these students are unable to communicate using the English language. Also shown in the table, the tourism students indicate mean increase in their post-test mean scores, showing a little bit favorable language skills after their dynamic education exposure. This is an evident that DynEd would really help in increasing the knowledge of the students particularly in English based on its principles of increasing two points is good enough for a beginner.

#### Pre-Test and Post-Test Scores across Tribes

Shown in Table 5 are the pre-test and post-test scores of students coming from different tribes.

Table 6. Pre-test and Post-test Scores across Tribes

	3	0.6		0.7
Mandaya			Elem. Level	Adv. Elem level
	14	1.3		
Manobo			Beginner	Beginner
	22	0.6		
Matigsalug			Beginner	Beginner
	4	0.7		

B'laan			Beginner	Elem. Level
	7	0.7		1.1
Kalagan			Beginner	Beginner
	3	0.6		0.7
Mandaya			Elem. Level	Adv. Elem level
	14	1.3		1.7
Manobo			Beginner	Beginner
	22	0.6		0.8
Matigsalug			Beginner	Beginner
	4	0.7		0.8
T'boli			Beginner	Beginner
	4	0.6		0.6

It appears in Table 6 that the tribes of ATA, Bagobo, Kalagan, Manobo, Matigsalug and T'boli students were classified as beginners before the dynamic education, which means the participants can only speak and understand a few phrases in English, and has knowledge of basic English grammar, such as pronouns and simple WH question formation. However, in the post-test scores, said respondents are still classified as beginners. This means that these students can use short sentences to answer simple questions, but sentences are short or fragmented, limited to basic patterns. This indicates that these students did not improve their ratings after they were exposed to dynamic education. This may imply that their exposure to the said intervention was not very effective since no difference was noted after the respondents' involvement in the said dynamic education program. This may further implies that 10 hours of exposure is not enough for the IP students who are just started to be exposed in the technology. This corroborates to the study of Napil (2014), that more than half of indigenous students aged 4-16 years (58%) even in Western Australia were rated by their teachers as having low over-all academic performance.

On the other hand, B'laan and Mandaya students have indicated a favourable change after their exposure to the dynamic education. This implies that the program was found helpful for the said groups of IP students. This implies that the B'laan and Mandaya were unable to communicate in English, but their exposure to the said intervention could have improved their communication skills using English language. This result supports the claim of Castillo (2001) who explained that exposure of students to advances in technology clearly relates to English proficiency achievement. In fact, Chun and Brandl (1992) also stated that the interactive and multimedia capabilities of the computer make it an attractive teaching/learning tool for students, thus

supports maximum learning potential.

#### Difference on Pre-Post Mean Gain Scores of the IP Students across Tribes

Shown in Table 7 are the results of the test of difference in the pre-post mean gain of the IP college students.

Table 7. Difference on Pre-Post Mean Gain Scores of the IP Students across Tribes

	P	Decision	Interpretation
Pre-Post Mean Gain Scores of the IP College Students	.001	Reject Ho	Highly Significant

Note: Significant at  $p < .05$

It appears in the table a p-value which is less than 0.05 alpha level indicating significant difference in the pre-post-main score of the IP college students in favour of the post-test. The test of difference in the gain scores of the IP students as shown in Table results to probability value which is less than 0.05 level of significance, indicating significant difference in the mean gain scores of the respondents when the respondents were grouped by tribes. Data imply a favourable change in the performance of the respondents after their exposure to the dynamic education and as noted earlier, B'laan and Mandaya made a difference in the mean gain scores.

Generally, the students have significantly improved their ratings in the post-test and this favourable difference may be attributed to students' exposure to the dynamic education. The null hypothesis has no significant difference between the pre-post mean gain scores of the IP college students. It is rejected giving favour to the post-test ratings. Therefore, Dyned is effective in dealing with language enhancement. This corroborates the idea of Klent (2007) that schools must improve facilities and promote enhancement programs in order to maximize learning of the students, and Corldhill (1996) added the idea that using computer software program in teaching and reinforcing a comprehensive range of grammar topics.

#### Difference in mean scores between Genders

Shown in Table 8 are the difference of the mean ratings of the respondents across gender found on the next page.

	F	T	p	Decision	Interpretation
Pre-test	3.163	.071	.994	Accept Ho	Not significant
Post-test	2.621	.248	.806	Accept Ho	Not significant
Mean Gain	0.821	.368	.747	Accept Ho	Not significant

Significant at  $p < .05$

It appears that both male and female respondents do not differ significantly in their pre-test, post-test and mean gain scores. This implies that all respondents regardless of gender equally perform as evident in their mean ratings. This further implies that the null hypothesis of no significant difference in the pre-test, post-test and mean gain scores of the respondents classified by gender is accepted. This means that no matter what gender the students belong, if they are going to be exposed to the DynEd program and practice well, there is an assurance of improvement in language proficiency. This implies that the software exposure or trainings premised on the holistic and authentic approaches to learning and adopts student/participant – centered methodology. The findings agree with the conclusions of the study of Frigaard (2002) who found out that the computer laboratory was beneficial tool benefiting students. Further, these computer activities have become their favourite part of the class that improved their skills.

#### Difference in the Language Test Scores across Colleges

Shown in Table 9 are the results of test of difference in the Language Test Scores across colleges in terms of their mean ratings that could be found on the next page.

Data in Table 9 revealed that there is no significant

Table 9. Difference in the Language Test Scores across Colleges

	F	P	Decision	Interpretation
Pre-test	0.155	.997	Accept Ho	Not significant
Post-test	0.636	.762	Accept Ho	Not significant
Mean Gain	1.698	.108	Accept Ho	Not significant

Significant at  $p < .05$  □

difference in the pre-test and post-tests mean gain

scores of all students coming from different courses as evident in the computed F-probabilities which are greater than 0.05 alpha level. Data imply that all respondents regardless of their courses have the same mean scores. This means that their mean differences may be different but the said differences are not statistically significant. This further implies that the performance of the education students in the pre-test, post-test, including their mean gain scores are the same with the performance of students from different colleges. Thus, the null hypothesis of no significant difference in the pre-test, post-test, and mean gain scores when analyzed by colleges is accepted. This means that every students particularly the Indigenous People students may improve in utilizing the computer-aided language learning. This corroborates the idea cited by Alviar (2007) that using computer aided language learning could enhance the English Proficiency of the students in practicing and recording their voice whether hands-on or even just in mobile method of exposure to the DynEd software.

Differences in the Language Test Scores across Tribes Shown in Table 10 are results of test of difference in the pre-test, post-test and mean gain scores of the respondents classified by tribes.

Table 10. Difference in the Language Test Scores across Tribes

	F	P	Decision	Interpretation
Pre-test	3.856	.001	Reject Ho	Highly significant
Post-test	4.457	.000	Reject Ho	Highly significant
Mean Gain	1.169	.330	Accept Ho	Not significant

*Significant at p < .05*

It appears that the re-

spondents significantly vary in their pre-test and post-test mean scores indicating that the two groups significantly differ in their performance and the cause of the difference as mentioned in the previous discussion is due to the higher mean ratings of B'laan and Mandaya students. On the other hand, the respondents do not significantly differ in their mean gain scores, which means that in the overall grouping of the respondents by tribe, they manifest the same level of communicative skills which means they still need to exert extra efforts to develop their skills together with computer-aided language learning devices. This corroborates the statement of Brandl (1992) that the interactive and

multimedia capabilities of the computer make it an attractive teaching/learning tool. This further corroborates the facts presented by Hall (1998), who emphasized that the use of word processing packages, electronic dictionaries, the World Wide Web, electronic mail, computer games aids to overcome the grammar deficit.

#### In-depth interview/FGD

In the focus group discussion (FGD), student informants from various indigenous groups yielded the following common responses to the four questions given to them, to wit:

Perceptions about computer-aided language learning (CALL).

Informants generally were filled with a sense of anxiety as most of them were not familiar with CALL. However, as they had their hands-on sessions, their anxiety was slowly replaced with curiosity and awe as they anticipate and encounter “fun-filled learning activities”. They eventually realize the importance of CALL and how the program complements their classroom subject sessions. As informants puts it, Ata - Nahalo á to pog gamit to DynEd, Nalipay a lagboy to ug maka-anad-a to soin no teknolohiya. Bagobo “Para kadakel su mga katawan tam a mga basa sa English endu kaumanan su pidtalo a kategel sa kadtalo. Upama”, Matigsalog - “Ka peg neneng te Inglis ne linalahon epgakabulig te mo estudyante ne mateles neg pangguhod karuren epgakalimul suni te kautenean te estudyante te pagsulat” or (The computer-aided language learning helps the students become better communicators someday since it increases the capabilities of the students in terms of correct sentence construction). Informants were also in agreement that CALL would improve their communication skills and improve their grammar (Matigsalog - Para kadakel-sumgakatawan tam amgabasasa English endukaumanansupidatlo a kategelsakadtalo.)

Experiences in learning the English language via DynEd.

Mandaya – “Matigan da ako about sa mga spelling and correct grammar”, “Sa permiro excited gayod ako kay first time ko makaexperience sin-I ug ya prove gayod na aside sa lingaw ini, daig gayod sab matunan”, Ata – “ Kulba, excited”, Kalagan –“Niya kanggiginawa ko kanu kutika nu nasabutan ko na mapya”, another Kalagan says “Una-una madayg yang mga mangkalisud na pyagalawng o language peru tungud sisi na programa madayg yang ikatigaman ko aw ngad mawnuno awn bun ikadagan ku agad tagbis”, Bago-bo – “ Makamanamana lagengan ta sa libte a kapan-gagi para kaumanan su pangagi sya ba sa basa anga English”, Kalagan – “Niya kanggiginawa ko kanu



kutika nu nasabutan ko na mapya”, “Una-una madayg yang mga mangkalisud na pyagalawng o language peru tungud sidi na programa madayg yang ikatigaman ko aw ngad mawnuno awn bun ikadagan ku agad tagbis”, Matigsalog --“Ka tawag eg uyan kanta peendiye to meupiyang pagkahikahi pegmanimeg wey pegneneng” – (CALL brought us back and forth towards good pronunciation right enunciation and free ourselves from anxiety towards using the technology. Its great and fun, the instructions are clearly stated). More Matigsalog say “Nue timpou ne semi malemu unya buwa sug pakaheran at pagkalaggew ne hinugdan ne pagkatul-id nig pamineg” or (Sometimes it is not easy, since I experienced nervousness that can caused me panic and can’t concentrate), “nan tuenan ku ka meupiyang peg lalag wey te peg tabak te me inse” or (I learned that, learning the English language requires a lot of “should and must” for to be highly competitive in using the English), “Te hun-a, amaan natelesi wey na haldok se ware maiya computer diye te kanamin inged. Naupiana se ke eg pamineg kare iya wey eg iling te in panulu,masulug iya ka kateunan ne”, or (At first I exited and felt nervous because there’s no computer in our place. It’s amazing because if you just focus, listen carefully and follow the instructions, definitely you can get a lot of learning). These responses from the informants sum up the overall experience of the rest of the informants. IP students considered their CALL experience as nervousness at the onset as they learn how to navigate and use the computers but as their confidence and skills increased, they henceforth enjoyed their computer-aided language learning via DynEd experience.

Learned from CALL.

“Migkatawakosamgamadidalem a basana Ingles angaa pidtaloEndumadakel i nangatawanku a mgakatigansakapedtalo” or (I learned more words that I never heard and I learned how to communicate to other persons using the English language) says an informant from the Bagobo tribe, “nata ó to paglalag, woy pog” or (learned the proper pronunciation or diction) said by an Ata informant. Similar responses were also given by the rest of the informants as they lose self-consciousness and gain confidence in the speaking or speech component of the DynEd (i.e CALL) program. The speech activities simulates actual conversation situations and students are made to adjust their intonation and pronunciation, approximating the samples given of native English speakers.

Another Bagobo informant states “Due timpou ne semi malenu, unya buna sug pagkaheran as makalanggaew ne hinugdan ne pagkatul-id dana ka paugtaran wey sinugdul te me mangan” or (I learned to make use of my time since there was only a short time frame. I also learned that learning through a book is way different from computer-aided language learning. With CALL I was very excited and also not bored), from Matigsalog informants “Ka umew eg

uyan kanta te pegkasinsinundul ne katutuan iling te meupiyang pagkahi-kahi te me lalag” or (CALL leads us series of learning such as, sentence construction right pronunciation of words). The new learning environment away from the traditional classroom setting increases student interest in learning. Indeed, learning becomes fun. Further, students own up to how they use their time inside the laboratory since the allotted sessions given to them must be prudently used to finish the study path for each English subject with the DynEd component. Hence, it is not only the English communication skill that is targeted but also the value of proper time-management. Implications of learning from CALL.

Ata – “gipraktisan, mas na confident paggamit English”, Kalagan – “Yama implicate ko yang ikatigaman ko sikon sa CALL magunawa nang pagpaningog aw pagbasa”, “Makihalubilo sang kadayang aw di magkamumwa mag-istoriya sa pagunawa nan”, “Yaimprove ko yang, pronunciation ko sa tabang ng CALL. Pyagsundog ko yang ilawng sa computer, tapas hinay-hinay da maimprove”, Bagobo – “Niya nakatidto sa mapya ahh ungayan”, “Takaamung den sa umanggay a gangula ku I napan-gayangyan ku anga sa upama min na kapembitya sa pagidsan ta a manusya.”, Mandaya – “Daku yang gamit sin\_i kanak labi na sa umabotay na panahon labi na sa kanak kurso pagmahuman ko ini, kelangan ko gaud makipagcommunicate, sa kanak pakipagcommunicate maapply ko gayod ini”, Matigsalog – “Nakabuling seini te keddin kangalingen te menewen te peg uyan ka tamn nilalahan te mu duman etew”, “Ka DynEd nakabuling seini te taman peg iling te me in panulu, ka nilalahan wey ka pegpamineg”, “Seinei egpaneng te masulug ne me butang ilabi-e te kidding pegkahi teahi, pegpamineg wey pegneneng”, “Mingbehey seine kantale malayag ne pagteteng. Tenged te seinintik. Hudyi, matangen me estudyante kaya huklu te peg apuya te kanean ne katuenen te inglis ne lihalahan”, “Seini ne peg tudlu, dakel-e ka tabong te mu studyanti wey te mu kahirapan te englis”. Overall response is best given by a Matigsalog informant—“Mingbehey seine kantale malayag ne pagteteng. Tenged te seinintik. Hudyi, matangen me estudyante kaya huklu te peg apuya te kanean ne katuenen te inglis ne lihalahan.”— (It gives us the vision, that through this technology, lots of students will be guided to improve their English proficiency). Computer-aided language learning further impresses the classroom lessons since actual English

communication situations are simulated for students to participate as they interact with computers. The activities provide students with opportunities to apply the basic rules on grammar, syntax and mechanics of the English language. All of these they experience without the pressure of a critical professor monitoring the student's performance. Thus, the learning environment is friendly and the student learns at his own pace without as stated earlier, the prying eyes of the teacher.

## V SUMMARY OF FINDINGS, CONCLUSIONS AND RECOMMENDATIONS

This chapter presents the summary of findings, conclusions and recommendations of the study.

The study is about the effects of computer-aided language learning and the experiences of the Indigenous People students. It aims at identifying the effects of computer-aided language learning in developing their language proficiency. Further, this study is designed to document their experiences and opportunities given to them during the DynEd sessions and proposed an enhancement program based on the findings.

### Summary

The study is about the effects of computer-aided language learning and the experiences of the Indigenous People college students. It aims at identifying the effects of computer-aided language learning in developing their language proficiency. Further, this study is designed to document their experiences and opportunities given to them during the DynEd sessions and proposed an enhancement program based on the findings. The specific sub-problems of the study are as follows: What are the profile of the IP college students when grouped into gender, course, and tribe? What are the pre-test and post-test mean scores of the IP students in DynEd Placement test? Is there a significant pre – post mean gain scores of the IP students in DynEd Placement test when grouped into tribe? Is there a significant difference in the mean gain scores among IP students in DynEd Placement test when grouped according to tribe? What are the experiences of the IP college students in computer-aided language learning via DynEd? Based on the findings, what enhancement program can be proposed for the IP college students?

### Findings

Below are the pertinent findings of the study. Majority of the respondents were female Indigenous People students, and most of them belong to the Manobo tribe. For courses -taken, Teachers' Education got the highest enrollee of IP among the other courses offered in the university. The post-test mean score of the IP college students is greater than their

pretest mean score. The pre-test of the IP was described as beginner according to the Dyned Placement test. It is revealed that the post-test of the IP students was increased which is described as elementary level according to the Dyned Placement test. There is a significant difference between pre-test and post-test scores of the IP college students in DynEd. The significance of the difference between the mean gain scores of the IP college students was found significant at 0.05 level.

In addition, it was then revealed that the perception of the participants in an innovative and interactive approach in teaching the language, the students could learn more. They have favorable experiences in learning English language during the exposure of the program. These favorable experiences are as follows: fun, interesting, exciting and challenging. They described the different opportunities where they apply their knowledge in speaking the English language. Most of them said this made them talking with their members of the family and classmates, or even in the school sharing of thoughts, reporting certain topics, dramatizing an event, and explaining concepts using English language.

### Conclusions

Based from the foregoing findings, the following conclusions are drawn:

The post-test mean score in the IP is greater than the pretest mean score in DynEd. It is revealed that the posttest of the IP college students is 1.0, which is described as elementary according to the Dyned Placement Levels in dynamic education. The conduct of computer assisted language learning through dynamic education is helpful in acquisition and enhancement of the students' knowledge and skills in English proficiency based on the results of their post-test which is considered as elementary level according to the DynEd placement test compared to their pre-test which was considered as beginner. Teachers find administering DynEd in the IP college students for the first time quite challenging, because most of the IP's having no skills in manipulating the computer added with the task to study the lessons in DynEd software. All participants in the study had positive attitudes towards the use of technology and strong intrinsic motivation such as personal curiosity and interest. The students also benefit from the program during a specified period of time as evident in the respondents' post-test results.

## Recommendations

Based from the foregoing findings and conclusions, the following recommendations are offered:

1. The study found out that the performance of the participants in the dynamic education is still within the elementary level. Thus, the researcher recommends that the conduct of the computer assisted language learning should be more intensified by adding more time for the DynEd laboratory exposure to make the learners more equipped with knowledge and skills on English proficiency.

2. The study found out that the conduct of the computer assisted language learning is effective in the acquisition and enhancement of the students' knowledge and skills. With this, the researcher recommends that this English enhancement program of the University of Mindanao should be continued to benefit the students.

3. The continuous evaluation of the students' test results should be made to monitor the strengths and weaknesses of the IP college students and its feedback will be used as basis in coming up with better instructional materials.

4. In view of the findings from this study, the utilization of the proposed enhancement program is recommended for the students together with IP students of the University of Mindanao.

## REFERENCES

- Alderite, E. (2002). Multimedia and Proficiency in English. Unpublished. Institutional Research. University of Mindanao
- Alvior, L. (2007). Communiqu'e. A Journal of Research and Ideas of the College of Arts and Sciences. March to June 2007.
- B'laan History - <http://www.ncca.gov.ph/about-culture-and-arts/e-books/ebook.php?id=67&t=2>
- Banados & Ripoll (1999). CTS and interactive multimedia b-learning environments for teaching and learning English as a foreign language. Retrieved from <http://www.formatex.org/mic2006on> February 9, 2007
- Brandl, K. (2002). Integrating internet-based reading materials into the foreign language curriculum: from teacher- to student-centered approaches.
- Castillo, A. (2001). The effectiveness of the oral fluency kit on the performance of second language learners. Unpublished Dissertation, University of Mindanao.
- Chun, D. M., & Plass, J. L. (1996). Facilitating reading comprehension with multimedia. System, 24, 503- 519. <http://ilt.msu.edu/vol11num3/pdf/murphy.pdf>
- Corldhill, A. (1996). Software review: mastering German grammar - a personal German grammar tutor. On- Call, 10(2),42-43.
- DynEd Europe, (2014). Retrieved May 12, 2014 from <http://www.dynedeurope.com/home#>
- DynEd, (2014). Retrieved May 12, 2014 from <https://www.dyned.com/us/about/>
- Frigaard, A. (2002). Does the computer lab improve student performance on Vocabulary, grammar, and listening comprehension? Retrieved November 19, 2007 from <http://edres.org/eric/ED476749.htm>.
- Faircloth, S., Tippeconnic, JW. (2010). The Dropout/ Graduation Rate Crisis Among American Indian and Alaska Native Students version <http://www.readbag.com/civilrightsproject-ucla-research-k-12-education>
- Glimpse, W. (2007). Assessing English Language Proficiency. Copyright 2007. Retrieved April 2, 2007 from <http://www.proximityone.com/elp.htm>
- Klent, F. (2001). Visual Communication in Web-based Learning Environments. Retrieved from [ifets.ieee.org/periodical/vol\\_4\\_2002/klett.pdf](http://ifets.ieee.org/periodical/vol_4_2002/klett.pdf) on March 1,2007
- Knowles, L. (2004) Journal of Communication and Education Retrieved from <http://www.language-magazine.com> on February 9,2007.
- Little, David (1996) Freedom to learn and compulsion to interact: promoting learner autonomy through the use of technologies. <http://elc.polyu.edu.hk/cill/HASALD/CALL-the.htm>
- Muaña, Jane. (2011). Academic performance of ip students. Retrieved June 28, 2013, from <http://www.termwarehouse.com/essay-on/Academic-Performance-Of-Ip-Students/49643>

Napil, M. (2014). The beliefs and strategies of Filipino Language Learning and the Academic Performance of the Indigenous People (IP) of the University of Mindanao. Unpublished Dissertation

Ompang, M. (2001). The Mandaya Ethnic Group. Retrieved May 17, 2014, for <http://www.ncca.gov.ph/about-culture-and-arts/articles-on-c-n-a/article.php?igm=4&i=239>

Proficiency In English Declines Social Weather Stations <http://www.sws.org.ph/pr060418.htm> Retrieved: July 30, 2014

Quito, S. (2008). Incidence of interactive teaching methodologies in the english classroom for improving communicative skills in the students of second year of Emiliano Ortega Espinoza School in the period may, july 2007.

Recla, E. (2011) Ethnicity and Reading Proficiency of Grade V Students of IP School in Marilog District. Unpublished master's thesis University of Mindanao, Davao City

SWS (200618) April 2006 March 2006 Social Weather Survey: National Language Learning & Technology, 6(3), 87-107. <http://llt.msu.edu/vol11num3/pdf/murphy.pdf>

Velasquez, J. (2013). Mandaya. Retrieved May 17, 2014, for [http://litera1no4.tripod.com/mandaya\\_frame.html](http://litera1no4.tripod.com/mandaya_frame.html)

# DESIGN AND SIMULATION OF A LOW GROUND AND LOW WIND SPEED ENERGY TURBINE GENERATOR

GILLERT M. BONGCAC

College Instructor, Jose Rizal Memorial State University  
Main Campus, Dapitan City, Philippines  
phyton\_gil@yahoo.com

## ABSTRACT

*This study presents a design and simulation of a low ground and low wind speed energy turbine generator. The design uses a low wind speed ranges from 1 m/s to 10 m/s. The wind speed is simulated in the Matlab Simulink software which produces variable power output depending on the wind speed. The design starts to stabilized at 4 m/s wind speed with a power output of 3.63 watts. The wind speed stabilizes longer at maximum wind speed. The design proves that it is feasible to used this wind energy turbine for a low wind speed source which can generates enough power for any electrical energy requirements up to 10 watts.*

**Keywords:** *Wind speed turbine generator, Wind turbine design, Low wind speed turbine generator.*

## INTRODUCTION

This study focuses on small scale wind turbines that can operate on low wind speed and in low grounds (1 m/s below to 5 m/s or more). Since not everyone can afford large scale wind turbines and it requires fast wind speed to operate, we promote small scale wind turbines as an alternative.

Stand alone wind energy conversion systems WECS are suitable electricity suppliers for isolated communities, island communities or applications where the cost of grid connection exceeds the installation and maintenance cost of a WECS (Kirke, 1998). Finding a suitable generator for a small scale wind turbine is challenging. The generator should not only be small in size but also needs to have low starting torque and high voltage-to-rpm ratio (Kishore & Priya, 2013). In the past, the majority of installed wind turbines were fixed-speed wind turbines with a squirrel cage induction generator, known as the 'Danish concept.' However, the dominant technology in the market at the moment is doubly fed induction generator (DFIG) wind turbines. This concept can employ different generator types, such as an induction generator or asynchronous generator, either with permanent magnets or external electrical excitation (Ozgener, 2007). It has been suggested that the generators equipped with permanent magnets (PMs) are more suitable for small size wind turbines because of their higher efficiency compared with other generators and using gear-less high efficiency small-scale wind energy portable turbine eliminates cogging torque and thus improves the start-up speed of the wind turbine (Priya, 2005).

Designing a small-scale wind turbine for very low wind speed applications is quite different than designing a conventional large scale wind tur

bine. Having to change the design from large scale to small scale and maximizing the power output is a big problem. There are several parameters such as blade profile, twist angle, chord length, solidity, and tapering angle, which need to be optimized simultaneously according to the operating conditions at low wind speed.

Many parts are change to replace the size factor and its ability to harness wind energy like making the blades into a fan type rather than being tapered. Increasing the cord length of the blades linearly from root to tip (increasing from root to tip) and twisting it from the hub to the tip. Changing from a common airfoil to a flat plate. The solidity should also be increase. The most important to be change is the generator itself. These changes will help generate more power in very low wind speed than the design of larger wind turbines.

## Objective of the Study

The objectives of this study are:

1. To design and simulate a low ground and low wind speed energy turbine generator.
2. To evaluate the power output, wind speed and operating range of the design.
3. To verify the design using Matlab Simulink software.

## METHODOLOGY

### Research Design

The focus of this study is to enhance the small scale wind energy generator output, lower the cut-in speed and widen the operating range. For the research design, we need to study how a generator further increase its power output.

## Research strategy and Research design

This research is a quantitative research and experimental design. To perform the study we need to evaluate the generator design of the wind turbine. In doing so, we can investigate how the SWEPT with axial flux slotless generator affect the power output, the cut-in speed and the operating range of the system.

## Data Collection, Measurement and Analysis

The data to be collected are the output voltage of the generator, the cut-in wind speed, the range of operating wind speed, the peak power of the generator wind turbine. The measurement to be used to investigate the performance of a generator in laboratory, normally it is coupled with a dynamometer motor and the wind turbine is emulated by varying the speed of the dynamometer motor but we can only use a simulator for measurement.

While to measure the cut-in and range of wind speed, we compare the results with similar size small scale wind energy generator. For the efficiency and power measurement, we use the simulator to compare the results in different wind speed. We need to analyze how the how the new generator increase the voltage output. What affects the internal impedance most. The effect of the new generator to the cut-in speed and the range of wind speed. The efficiency in various wind speed using the independent variables. And the effect to the peak power. Using Matlab to analyze the output of the system.

## Research Methods

This part is going to present how to collect, measure, process and analyze the data and present the procedure and flowchart in conducting the experiment in simulation.

## Collection, Measurement, Process, and Analysis.

The collected data are the power output, generator voltage, cut-in speed, the range of operating wind speed.

Connect the multi-meter parallel to the generator and find the load resistance and corresponding output voltage in a given wind speed. Then use the root mean square value to calculate the electrical power. Increase the wind speed (constant speed) at a fixed load resistance to find the highest power output. Measure the root mean square (rms) value to calculate the electrical power. The arithmetic mean is calculated as the representative value for the respective variables. The internal impedance of the generator is measured by varying the load resistance and the wind speed in such a manner that the constant rotational speed of the wind turbine rotor is maintained. Given the value of

the output voltage and the resistance of the generator at a rated wind speed we can calculate the power output of the wind turbine.

## Design flow chart

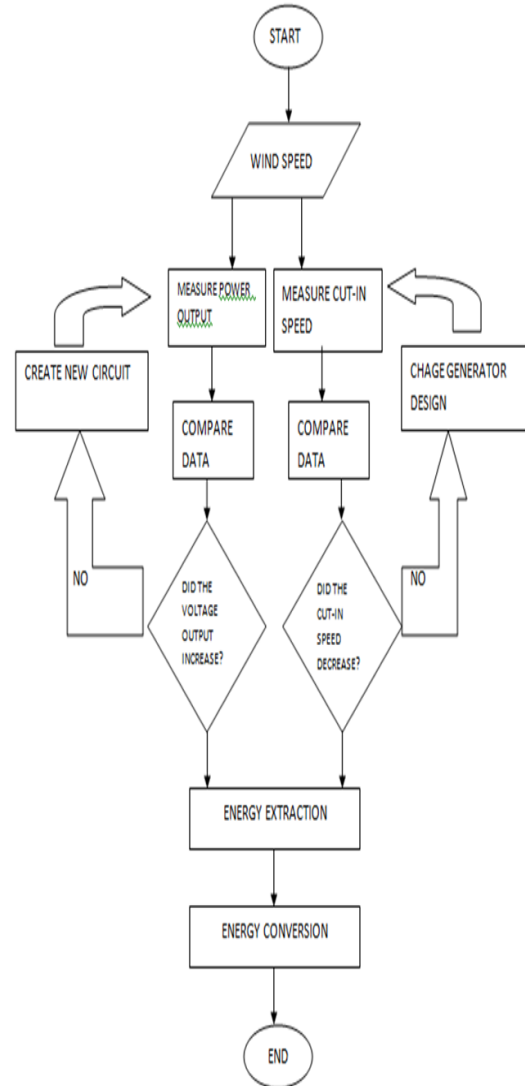

Figure 1: Design Flow Chart

## SIMULATION, FINDINGS AND INTERPRETATION

### Designed and Simulated Result of a Low Ground and Low Wind Speed Energy Turbine Generator using Simulink

The small scale axial flux wind turbine generator circuit is shown in figure 2. It is simulated using Matlab software.

Wind speed is varied mimicking the low ground and low speed wind. This wind speed is then inputted to the wind turbine in figure 2.

The power output is then determined as shown in figure 3. The input wind speed and the output power data are tabulated in table 1.

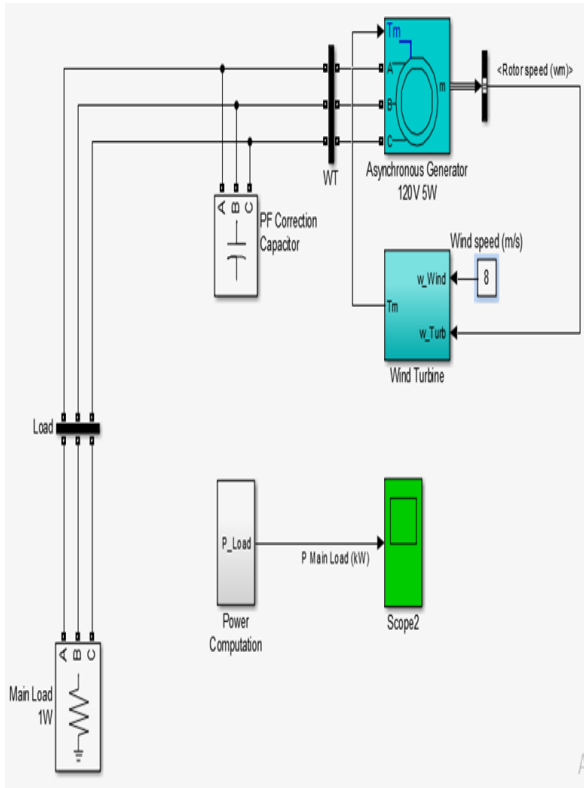

Figure 2: Small-scale Axial Flux Wind Turbine

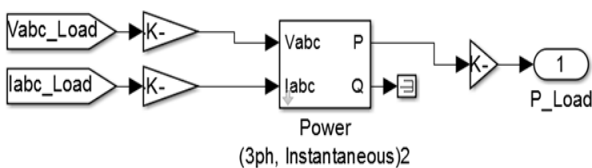

Figure 3: Power output circuit

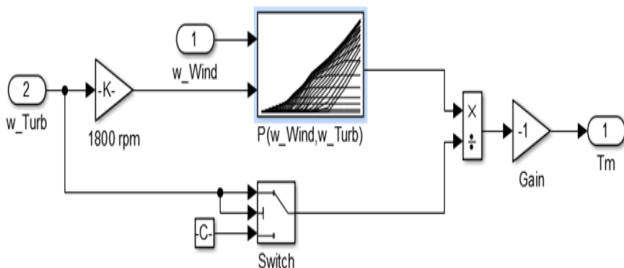

Figure 4: Wind turbine circuit

### Evaluated Output Power, Wind Speed, and Operating Range

Table 1: Small-scale Axis Flux Wind Turbine Generator Simulation Results

Wind Speed	SAFWTG/ load Power Output
1 m/s	0.20
2 m/s	1.17
3 m/s	2.68
4 m/s	3.63
5 m/s	5.05
6 m/s	5.78
7 m/s	6.92
8 m/s	8.02
9 m/s	9.15
10 m/s	10.2

Table 1 shows the data collected from the simulation using Matlab simulink. The wind speed is too slow for the cut in speed having the SAFWTG with load power output to be only 0.2W. The wind speed increase, it is enough for the cut-in speed making SAFWTG with load power output to be more than 1W.

As the wind speed increases to 3 m/s it can produce twice the amount of SAFWTG with load power output as the cut in speed.

Table 2: SWTG and SAFWTG Power Output Results

WIND SPEED	SWTG POWER OUTPUT	SAFWTG POWER OUTPUT
1 m/s	0	0.20
2 m/s	0	1.17
3 m/s	0.6	2.68
4 m/s	1.1	3.63
5 m/s	1.9	5.05
6 m/s	2.5	5.78
7 m/s	0	6.92
8 m/s	0	8.02
9 m/s	0	9.15
10 m/s	0	10.2

With the wind speed continue to increase the SAFWTG with load power output fluctuation increases then stabilized at 3.63W. The faster the wind speed the higher the fluctuation and the SAFWTG with load power output.

The fluctuation further increases as the wind speed approaches the maximum operating speed. The nearer the wind speed is to the maximum operating speed the SAFWTG with load power output takes longer to stabilize.

When the wind speed is at its maximum operating speed of the SAFWTG, it takes a while to stabilize. Further increase in wind speed will result to an un-stabilize SAFWTG with load power output

### CONCLUSION

Based on the results and findings, the following conclusions are drawn;

1. The design and simulation of a low ground and low wind speed energy turbine generator exhibits power output even at a very low wind speed input. This proves that it is feasible to used this design to generate electrical energy at a very low wind speed.
2. The design produces stable power output at the wind speed of 2 m/s. This means that the operating range of this design can is from 2 m/s.
3. The simulation using Matlab Simulinks proves that the low ground and low wind speed is a viable source of electrical energy which can power up 10W of electrical requirements.

### REFERENCES

- Kirke BK.(1998). Evaluation of Self-Starting Vertical Axis Wind Turbines for Stand-Alone Applications. Retrieve from the website [http://upload.wikimedia.org/wikipedia/commons/c/c9/Wing\\_profile\\_nomenclature.svg](http://upload.wikimedia.org/wikipedia/commons/c/c9/Wing_profile_nomenclature.svg).
- Kishore RA, Coudron T, Priya S. (2013). Small-scale wind energy portable turbine (SWEPT). Journal of Wind Engineering and Industrial Aerodynamics Retrieve from the website [http://upload.wikimedia.org/wikipedia/commons/c/c9/Wing\\_profile\\_nomenclature.svg](http://upload.wikimedia.org/wikipedia/commons/c/c9/Wing_profile_nomenclature.svg)
- Priya S. (2005). Modeling of electric energy harvesting using piezoelectric windmill. Applied Physics Letters. Retrieve from the website [www.home-energy.com/int/ebv100 technical.htm](http://www.home-energy.com/int/ebv100_technical.htm).
- Ozgener O, Ozgener L. (2007). Exergy and reliability analysis of wind turbine systems: A case study. Renewable & sustainable energy reviews. Retrieve from the website [www.superwind.com/swe/index.htm](http://www.superwind.com/swe/index.htm).



# DESIGN AND SIMULATION OF A MAXIMUM POWER POINT TRACKING PHOTOVOLTAIC SOURCE TO POWER WATER PUMPING SYSTEM USING MATLAB

GILLERT M. BONGCAC

College Instructor, Jose Rizal Memorial State University  
Main Campus, Dapitan City, Philippines  
phyton\_gil@yahoo.com

## ABSTRACT

*This study presents a design and simulation of a maximum power point tracking photovoltaic source for water pumping station. The design is simulated using Matlab software and it exhibits expected output in terms of power and speed of the motor. The maximum power point tracking give optimum output performance. The design is efficient and viable to be used as a power source of the water pumping system.*

**Keywords:** *Maximum power point tracking photovoltaic, design of MPPT PV source for pumping station, Power source of pumping station using MPPT PV*

## INTRODUCTION

Maximum Power point Tracking (MPPT) system enables the maximum power to be delivered during the operation of the solar array and which tracks the variations in maximum power caused by the changes in the atmospheric conditions. It is vital for the PV pump system to operate on its required power for the efficiency purposes.

There's a significant increase in efficiency of energy production from PV and the performance of the PV water pumping system (Fathi, 2015). Using more efficient pumps and reducing the amount of PV panels, additional Solar PV systems can be installed, without sacrificing the efficiency of the system (Amit, 2015). Muleta (2013), concluded that PV water pumping system is viable and more economical choice than the conventional Diesel pumps. For some reasons PV water pump has lower operation and maintenance resulting to lower water cost for Photovoltaic water pumps.

Harnessing of Solar power is not yet on its utmost degree of implementation. One of these gaps is the inefficient of solar harnessing during cloudy days and shading of solar panels (e.g. caused by trees and clouds). The investigation of some other converters such as boost, cuk, and buck-boost along with the proposed MPPT techniques to improve flexibility in the choice and configuration of PV array connection.

To address these gaps, it is essential to improve the MPPT and the converter design.

### Objective of the Study

The objectives of this study are:

1. To design and simulate a MPPT PV source to power

- er the water pumping system
2. To evaluate the speed of the motor and the efficiency of the design.
3. To verify the design using Matlab.

## METHODOLOGY

### Research Design

The design consist of various parts namely the PV arrays, 12v DC pump, MPPT system and DC-DC Cuk converters. The optimization will be focused on converting side which is the MPPT system and DC-DC converters. The main function of MPPT as discussed in the introduction is to regulate and transform the voltage into a desired voltage, turning to a much more efficient system. Figure 1 shows the design flow chart of the whole system.

### Data, Measurement and Analysis

The data to be collected in this study are the power from the PV arrays, power from cuk converter, in order to compute for efficiency of the system. From the solar irradiance, the PV arrays convert it to an electrical energy, which can be measured in watts. The MPPT system reads the harnessed power from the PV arrays. MPPT will act as a sensor determining if the voltage needs to be stepped-up or stepped-down meeting the demand of the pump. After the collection of the said data, each of it will be measured by transient response of the simulations. By this, we could get the Power from the PV array and Power from the converter. Afterwards, the efficiency of the MPPT system will be calculated using the data acquired.

**Collection, Measurement, Process, and Analysis.**

The design will be implemented in MATLAB r2016a simulation software. The measurement of the data can be catered through utilization of Blocks in Simulink. Oscilloscope will be connected directly to PV arrays for measuring the power output and also in the output of the DC converter. The efficiency from each irradiance will be compared for further analysis.

**Modelling and Simulation**

This section involves the design experiment and validation of the design. Mathematical equations for the design are presented in this section and parameters of the DC converter, PV array, and motor is also presented. MATLAB r2016a will be used in simulation of the design. Tables will be provided to record the simulation results.

**Working Equation**

PV power and Output Power

$$P=VI$$

Efficiency of the system

$$Eff = \frac{P_{out}}{P_{pv}}$$

P<sub>out</sub> = Power output of Cuk converter

P<sub>pv</sub> = Power output of PV array.

**SIMULATION, FINDINGS AND INTERPRETATION**

Figure 2 shows the whole system simulated in Simulink of PV water pump with MPPT. Each block has subsystem with specific function. BPSX150s block is the PV array. MPPT controller is the system which tracks maximum power. The CUK converter is the DC-DC converter used in the system. PMDC motor is the load used in the system.

Figure 2: Simulink modelling of the whole system PV water pump

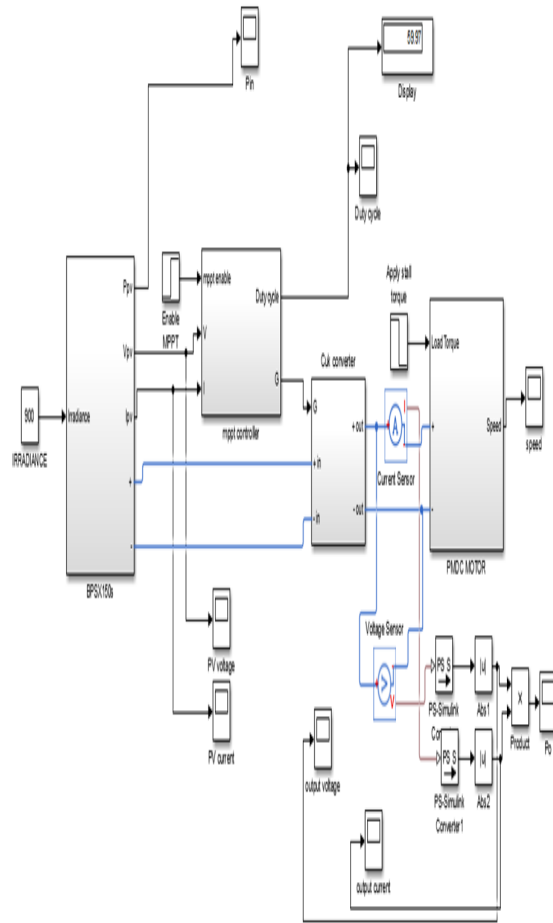

**Design flow chart**

Figure 1: Design Flow Chart

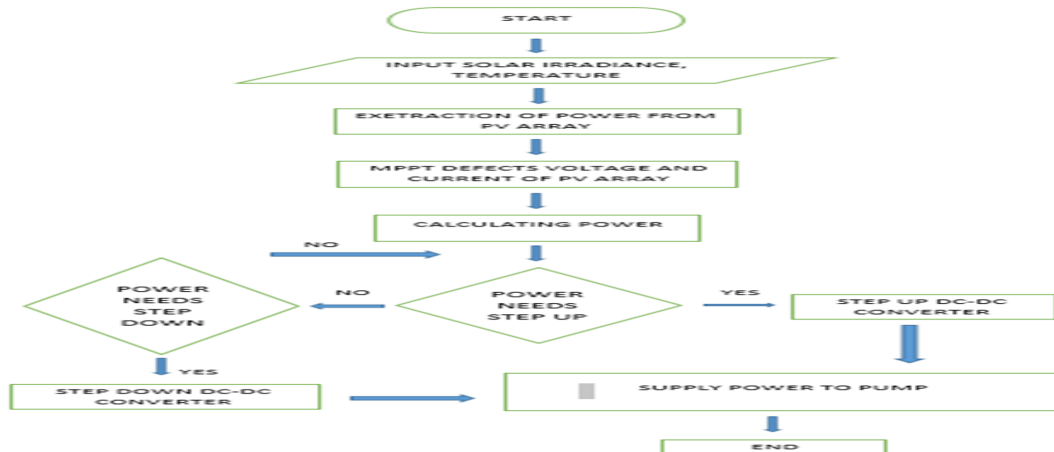

Figure 3: PV array (BPSX150s) 72 cells connected series Simulink model with maximum power output of 150 W

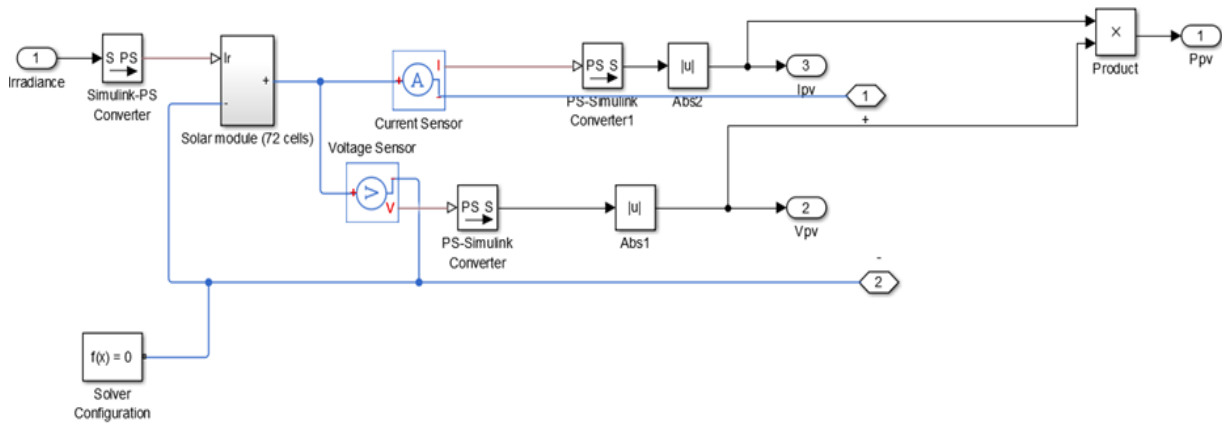

Figure 2 is the simulink modelling of the PV water pump. The MPPT controller input is connected directly to the PV arrays and the output of the MPPT is connected directly to the Cuk converter. The output of the Cuk converter has a current and voltage sensor to better control the PMDC motor in which the speed of the motor is measured.

Figure 3 shows the PV arrays of the design, It is connected directly to the MPPT and it has a maximum rated power output of 150 W.

Figure 4: MPPT controller Simulink model

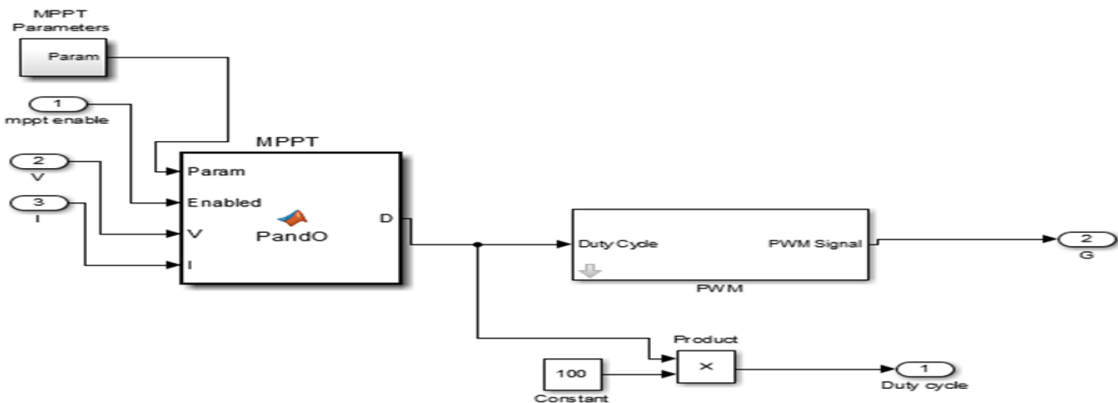

Figure 5: Cuk DC-DC converter Simulink modelling

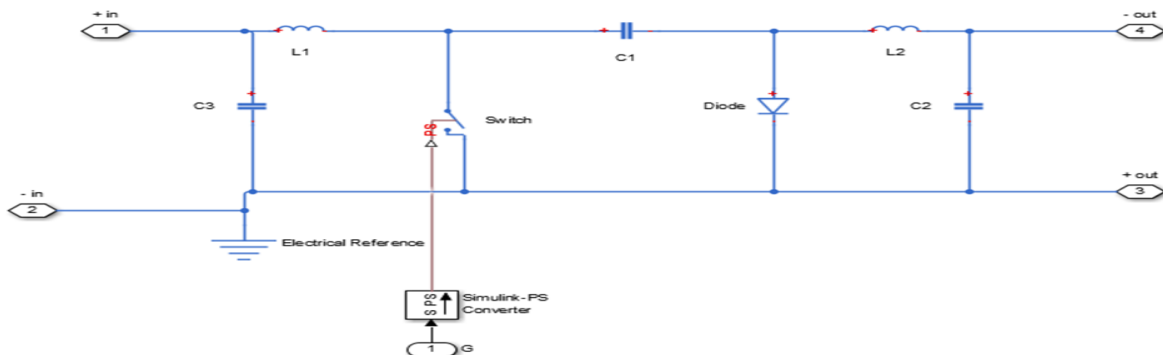

Table 1 shows the data collected from the simulation. Irradiance is the main variable input. From the varied irradiance, powers harnessed from PV array, power output from cuk converter and speed varies too. Duty cycle determines if the voltage is stepped up or stepped down. In the table it shows the efficiency from the corresponding varied irradiance. The efficiency is computed based on the PV output power and the cuk converter power output.

Table 1: Result of simulation with speed and efficiency

Irradiance (w/m <sup>2</sup> )	PV output power	Cuk output power	MPPT system duty cycle	Speed (RPM)	Efficiency (%)
400	56.59 W	52.8 W	57.31	220.8	93.4
500	71.22 W	69.12 W	59.97	263.3	96.24
600	80.79 W	76.67 W	59.97	286.9	94.90
700	85.41 W	81.85 W	59.97	297.2	95.83
800	83.42 W	79.83 W	59.97	304.0	95.69
900	83.69 W	79.14 W	59.97	309.2	94.56
1000	85.15 W	79.77 W	59.97	309.3	93.68

The highest efficiency during the simulation is 96.24% in which the irradiance is 500w/m<sup>2</sup>. But the design exhibits stability

Finding shows on the results that the increase in irradiance contributes to the increase in speed of the pumping motor. This is due to the maximum power point tracking of the photovoltaic system.

### CONCLUSION

Based on the results and findings, the following conclusions are drawn;

- 1.The design and simulation of the maximum power point tracking photovoltaic source for water pumping system can drive motor pumping system based on the output speed of the results.
2. During simulation, the design exhibits high efficiency and therefore can be considered as viable source of electrical power to supply the pumping station.
3. Matlab software is very dependable in designing and simulating complex system. During the verification, it shows that each subsystem produces output parameter in accordance to the expected output of the design.

### REFERENCES

- Amit K. K.,(2015). The Rising Sun: Analyzing Potential of Energy Efficient Solar Photovoltaic Water Pumping Systems in India. Humboldt State University.
- Fathi A O A.,(2015). Maximum power point tracking techniques for photovoltaic water pumping system. University of Bath.
- Muleta B., (2013). Feasibility Study for Replacement of Diesel Water Pumping System with PV Water Pumping System. Addis Ababa University.

# DESIGN OF A PIEZOELECTRICAL CANTILEVER BEAM ELECTRICAL CONVERSION USING WIND ENERGY

GILLERT M. BONGCAC

College Instructor, Jose Rizal Memorial State University  
Main Campus, Dapitan City, Philippines

## ABSTRACT

*This research study presents a design of a piezoelectrical cantilever beam energy conversion using wind energy as a source of energy to vibrate the beam. The cantilever beam is use to harness the wind energy in this design. The vibration of the beam produces an alternating current. The design is simulated, evaluated and verified using LTSpice software and COMSOL Multiphysics software. The result of the simulation produces viable output power and it is stable at low wind pressure and low frequency vibration.*

**Keywords:** *Piezoelectrical cantilever beam energy, Wind to electrical conversion using piezoelectrical cantilever beam*

## INTRODUCTION

Energy harvesting is a process of capturing minute amounts of energy that would otherwise be lost such as sound, light, and vibration or movement, accumulating them and storing them for later use. In this research, we will be using vibrations as a source of energy. With the birth of technology, low-power consumption electronics existed. Thus, the topic of energy harvesting gained much attention. This study will predominately give emphasis on harvesting energy from pre-existing vibrating host structures through base excitation of cantilevered beam. Piezoelectric cantilevered beams are widely used structures in energy harvesting applications due to their high flexibility and low natural frequency. This study claims that this system when applied on large scale can generate a high amount of power that can power either some small, low power electronic system directly, or to charge an electrical storage reservoir.

Piezoelectric materials have been used for energy harvesting because of its large power densities and ease of application. Typically, piezoelectric energy harvesters are cantilevered structures with piezo ceramic layers that produce alternating voltage output due to base excitation (Erturk 2009). Piezoelectric materials in mechanical-to-electrical energy conversion are very efficient means to supply energy needs for small electronic equipment (Ozpak, 2014). Energy harvesting from ambient vibrations by using numerous form of transduction has been recognized as a viable means for powering smallelectronic devices and remote sensors in order to eliminate their dependence on external power sources such as batteries or power grids. With such self-powered capabilities, these devices and sensors can operate in an uninterrupted fashion over prolonged periods of time. Different types of piezoelectric transducer can be used to harvest vibration energy, including monomorph, bi-

morph, stack or membrane. Each configuration has its own advantages and limitations, and in general it is not possible for an energy harvester to perform well in all applications. One and two degree of freedom lumped-parameter spring mass models were used to idealize the bimorph cantilever structure. Electromagnetic, electrostatic and piezoelectric transductions are the three basic conversion mechanisms commonly used to convert the basic vibrations to electrical energy (Porwal, 2013). The major application area for energy harvester as power sources for wireless sensors, thereby replacing currently used batteries which suffer from a finite lifespan and pose environmental issues during disposal (Patel, 2013).

From the literature review conducted in this study, it is clear that the fundamental and most pressing limitation of energy harvesting devices remains their low power outputs. Therefore, in an effort to achieve a higher power output, it was considered that a modeling approach would be useful. The cantilever beam that is used for harvesting is not yet enough to generate high power output. However, it was considered that the model should not simply predict outputs of the device (e.g. power or voltage) when provided with dimensions and material characteristics, since this still would not provide guidance on how to design a harvester for an increased power output; i.e. the designer still has to rely on a trial-and-error approach. Also, the connection between risk and supposed benefits has not been studied in length.

To address this gap, first is we should improve the circuitry of the piezoelectric harvester to maximize the amount of harvested energy. We need to improve the cantilever beam device through the use of piezoelectric element with high piezoelectric constants. If these can be achieved, the enhanced level of the output power can lead into realizing a greater number of possible applications.

On same instance, this study goes some way towards closing the gap existing between the required power of the electric devices and systems, and the amount of power that can be harvested using the piezoelectric cantilever beam.

### Objective of the Study

This study aims to:

1. Design of a piezoelectrical cantilever beam energy conversion using wind pressure as the source of energy.
2. Evaluate the performance of the design with respect to its output voltage, efficiency and power generated by using LTSpice Software and COMSOL Multiphysics.

## METHODOLOGY

### Research Design

The prototype is a cantilevered beam which will be attached into a fan. The beam structure that will be use is a bimorph structure. The use of the two active layers of the beam will increase the energy output of the harvester because it doubles the energy output of the harvester. Two individual harvesters were integrated with a fan in order to harvest wind energy. The fan attached to the device will produce air which will hit the beam and cause vibration. Using fan as a primary source of air to cause vibration on the beam, it can be assure that the source of air is unlimited because its rotation rely on the amount of wind coming from the surroundings. A magnet is attached on the tip mass of each individual harvesters and the blades of the fan so that repulsive magnet forces would be induced in order to maintain the speed and vibration. A proof mass is also attached to the cantilever beam for bending purposes. Finally, the circuitry will absorb the vibration and converts it into electricity.

### Collection, Measurement, Process, and Analysis

For the initial investigation of the design, the collection of the required data is by performing simulation using LTSpice software and COMSOL Multiphysics 5.2a. Execute simulation using LTSpice with independent variables being controlled. The independent variables to be controlled for the harvesting circuit are the two independent AC sources and the load resistances. And for the verification of results, we will conduct the actual testing of the design in the actual environment. The output voltage will be measured using a voltmeter. Also, the results will be verified by manually calculating the values needed for the data to be collected.

To analyze the results easily and for easier comprehension, the values gathered after simulation and calculation will be recorded on tables to show the

difference between them and then the values gathered from simulation will be plotted in a graph.

### Modelling and Simulation

Piezoelectricity forms of coupling between the mechanical and electrical behaviours of the design materials. The materials exhibiting the piezoelectric effect are called the piezoelectric materials. The piezoelectric materials are squeezed (i.e. mechanically strained) in the simulation which produces an electric charge that is collects at the electrodes located on its surface.

### Design flow chart

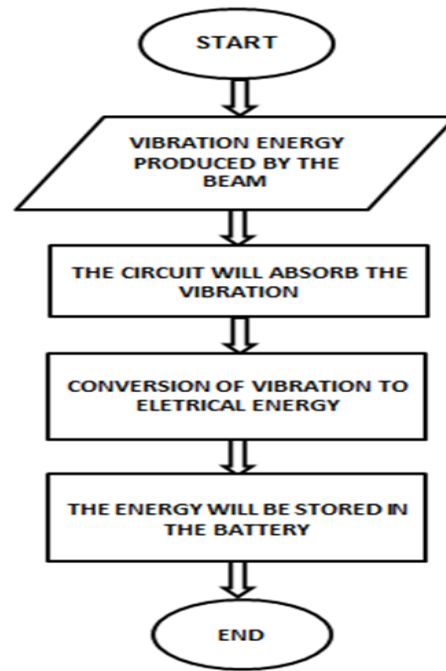

Fig. 1: Design Flow Chart

## RESULTS, FINDINGS AND INTERPRETATION

### Cantilever Beam Parameters

The piezoelectric energy harvester used in this design is a cantilevered beam with piezo-ceramic layers. The energy harvesting is directly connected in the energy harvester to an electrical load.

Alternating voltage output is generated during the cantilever beam vibration. The design of the piezoelectric cantilevers beam is shown in figure 1.

Table 1 show the cantilever beam parameter used in this simulation.

Table.1: Cantilever beam parameter

Parameters	Unit	Dimension
Cantilever beam	inch	8 x 0.3
Proof mass	inch	3 x 1.7

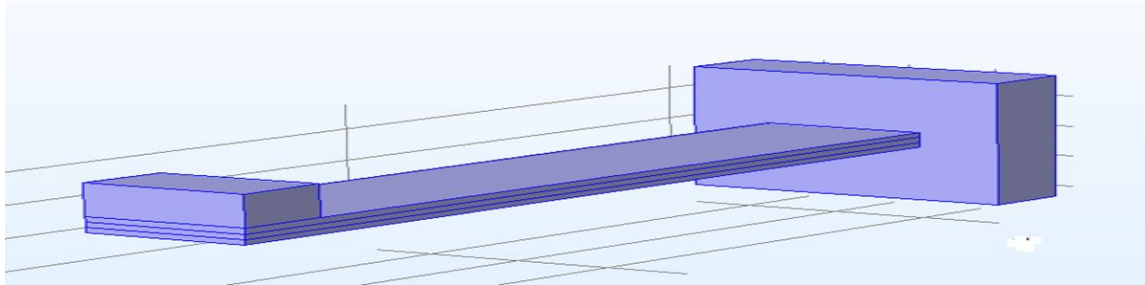

Figure 1: Design of Piezoelectric Cantilever Beam using COMSOL Multiphysics

Figure 2 shows the schematic circuit diagram of the design used for simulation using LTSpice and COMSOL Multiphysics.

The piezoelectric harvester passes to the bridge rectifier before it goes to harvesting module. The output load resistance is varied with respect to the different vibration frequencies. Data are measured and recorded in table 2 and table 3.

Figure 2: Design Schematic Circuit Diagram using LT Spice

The power output in different load resistance varies inversely as the frequencies increases, as shown in table 2, this is because of the decrease of current in the design. As the load resistance increases, the power slightly decreases because of the resonance frequency of the fundamental flexural modes of a cantilever because it is much lower than the other vibration modes of the piezoelectric element.

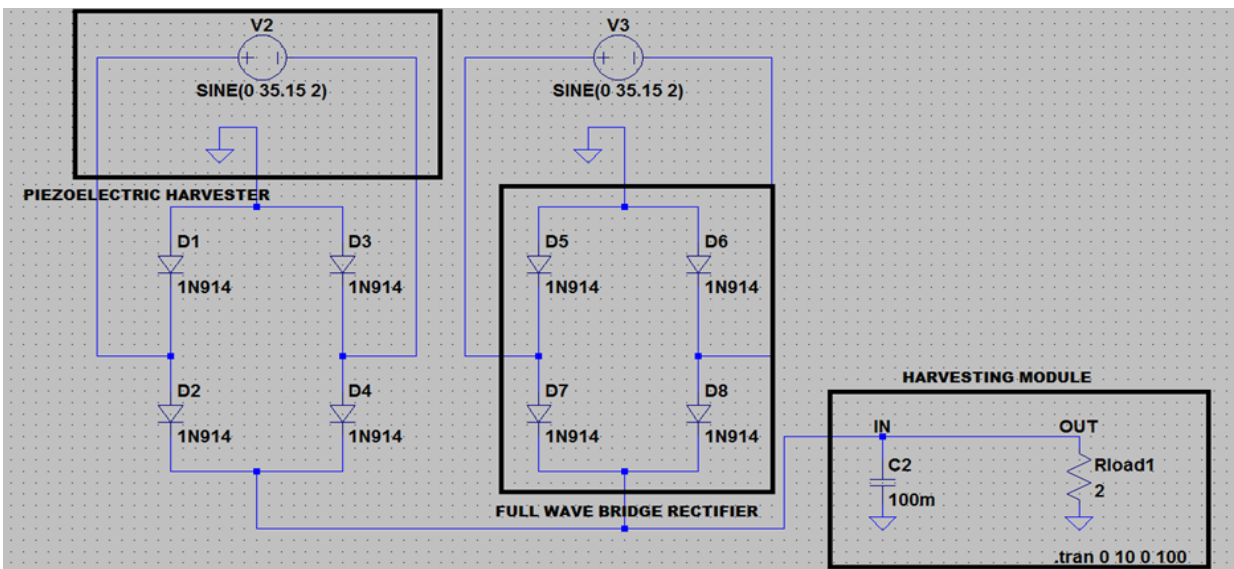

Table 2: Harvesting Circuit Results

Electrical Outputs												
	$R_{LOAD} = 2\Omega$			$R_{LOAD} = 4\Omega$			$R_{LOAD} = 6\Omega$			$R_{LOAD} = 8\Omega$		
Frequency	V	I	P	V	I	P	V	I	P	V	I	P
$f = 2$ Hz	22.8	11.2	256.4	21.3	6.5	138.6	20.8	10.4	216	20.6	10.2	211.9
$f = 4$ Hz	26.0	6.5	169.3	24.7	6.7	166	24.4	6.1	148.8	24.3	6.0	147.5
$f = 6$ Hz	27.5	4.5	124.9	26.5	4.4	116.8	26.1	4.3	113.6	25.9	4.3	112.5
$f = 8$ Hz	28.2	3.5	99.4	27.4	3.4	93.9	27.1	3.4	92.3	27.2	3.4	92.4
$f = 10$ Hz	28.8	2.9	83.1	28.0	2.8	78.6	28.0	2.8	78.5	28.0	2.8	78.4

Table 3: Wind to Energy Conversion Results

Wind Energy Conversion Efficiency						
At $R_{LOAD} = 2\Omega$						
Wind Pressure	Frequency	$V_{IN}$	$I_{IN}$	$P_{IN}$	$P_{OUT}$	Efficiency
3 lb/ft <sup>2</sup>	$f = 2$ Hz	28.2	11.0	311.1	256.4	82.4%
6 lb/ft <sup>2</sup>	$f = 4$ Hz	27.6	11.7	323.2	169.3	52.4%
9 lb/ft <sup>2</sup>	$f = 6$ Hz	27.3	12.2	332.6	124.9	37.6%
12 lb/ft <sup>2</sup>	$f = 8$ Hz	27.6	12.5	344.1	99.4	28.9%
15lb/ft <sup>2</sup>	$f = 10$ Hz	37.8	11.8	447.5	83.1	13.6%
At $R_{LOAD} = 4\Omega$						
Wind Pressure	Frequency	$V_{IN}$	$I_{IN}$	$P_{IN}$	$P_{OUT}$	Efficiency
3 lb/ft <sup>2</sup>	$f = 2$ Hz	29.9	8.1	242.9	138.6	57.0%
6 lb/ft <sup>2</sup>	$f = 4$ Hz	29.5	8.6	254.7	166	65.2%
9 lb/ft <sup>2</sup>	$f = 6$ Hz	29.4	8.7	255.2	116.8	45.8%
12 lb/ft <sup>2</sup>	$f = 8$ Hz	29.6	8.7	257.1	93.9	36.5%
15lb/ft <sup>2</sup>	$f = 10$ Hz	29.9	8.3	249.1	78.6	31.6%
At $R_{LOAD} = 6\Omega$						
Wind Pressure	Frequency	$V_{IN}$	$I_{IN}$	$P_{IN}$	$P_{OUT}$	Efficiency
3 lb/ft <sup>2</sup>	$f = 2$ Hz	30.6	6.8	208.3	215.9	103.7%
6 lb/ft <sup>2</sup>	$f = 4$ Hz	26.4	4.4	116.6	148.8	127.6%
9 lb/ft <sup>2</sup>	$f = 6$ Hz	26.2	4.3	114.2	113.6	99.5%
12 lb/ft <sup>2</sup>	$f = 8$ Hz	26.1	4.3	113.9	92.2	80.9%
15lb/ft <sup>2</sup>	$f = 10$ Hz	30.9	7.0	216.6	78.5	36.2%
At $R_{LOAD} = 8\Omega$						
Wind Pressure	Frequency	$V_{IN}$	$I_{IN}$	$P_{IN}$	$P_{OUT}$	Efficiency
3 lb/ft <sup>2</sup>	$f = 2$ Hz	28.2	3.5	99.9	211.9	212.2%
6 lb/ft <sup>2</sup>	$f = 4$ Hz	27.5	3.4	94.3	147.5	156.3%
9 lb/ft <sup>2</sup>	$f = 6$ Hz	27.3	3.4	93.3	112.5	120.6%
12 lb/ft <sup>2</sup>	$f = 8$ Hz	27.3	3.4	93.5	92.5	98.9%
15lb/ft <sup>2</sup>	$f = 10$ Hz	27.6	3.5	95.4	78.4	82.2%

The wind pressure is inversely proportional to the efficiency of the design as shown in table 3. This phenomenon occurs because of the rapid drop of power output of the design even thou the load resistance is increasingly varied. The stability of the design occurs when the load resistance at 4  $\Omega$ . The power output is stable even if the wind pressure changes.

The highest efficiency occurs at the lowest wind pressures. This is because of the frequency of vibration is not great.



## CONCLUSION

Based on the results and findings, the following conclusions are drawn;

1. At minimal wind pressure, the cantilever beam vibrates which the design produces output power. The power produced of the design is enough to power small voltages devices.
2. During evaluation of the design circuit, The output voltage, power output and efficiency is stable at low wind pressure.

## REFERENCES

- Erturk, Alper(2009). Eletromechanical Modeling of Piezoelectric Energy Harvesters.Blacksburg, VA. Retrieved from [https://theses.lib.vt.edu/theses/available/etd-12042009-140326\\_unrestricted/Erturk\\_A\\_D\\_2009.pdf](https://theses.lib.vt.edu/theses/available/etd-12042009-140326_unrestricted/Erturk_A_D_2009.pdf)
- Ozpak, Yigit. (2014). Energy Harvesting from Piezoelectric stacks via Impacting Beam.Middle East Technical University. Retrieved from <http://etd.lib.metu.edu.tr/upload/12617662/index.pdf>
- Patel, Rupesh. (2013). Modeling, Analysis and Optimisation of Cantilever Piezoelectric Energy Harvesters .University of Nottingham. Retrieved from <http://eprints.nottingham.ac.uk/13246/1/thesis.pdf>
- Porwal, Himanshu (2013). Piezoelectric Transduction Mechanism For Vibration Based Energy Harvesting.Department Of Mechanical Engineering, National Institute Of Technology Rourkela-769008, India. Retrieved from <http://ethesis.nitrkl.ac.in/5402/1/211ME1161.pdf>

# STRUCTURAL MODEL OF STRATEGIC, COLLABORATIVE AND CULTURAL LEADERSHIP AS PREDICTORS OF QUALITY OF WORK LIFE OF SCHOOL HEADS

**SATURNINO E. DALAGAN, JR.**

Director for Student Services  
Institute of Education and Teacher Training  
Davao Oriental State College of Science and Technology  
zithromax78@yahoo.com

## ABSTRACT

*The study investigated the forms of leadership, namely, the strategic, collaborative, and cultural leadership to come up a strongest predictor of quality of work life of school heads, which in turn, explore the best fitting structural model that would be necessary to answer the seemingly not so desirable quality of work life of school heads. The causal relationship of research design was used in this study and the statistical tools were the multiple regression analysis and structural equation model. Findings revealed that strategic, collaborative, and cultural leadership jointly influenced quality of work life of school heads. Moreover, among the three important independent variables, the strategic and collaborative leadership obtained the significant result but only collaborative leadership satisfied the model for quality of work life.*

**Keywords-** *strategic leadership; collaborative leadership; cultural leadership; quality of work life; structural equation model*

## INTRODUCTION

Academic leaders possessed unique leadership skills which they believed to yield productive outcomes on their administrative operation. Collaborative, strategic and cultural leadership are claimed to be an effective leadership skills in manning an organization. In the like manner, these leadership skills can predict quality of work life, which in turn, can explore the best fit model of quality of work life of school heads. Ilmarenin (2001) investigated in his study that work demands and the environment; work organizations and the work community; the promotions and functional capacity; and the promotion of professional competence (Kouri, 2009) proved to be strongly associated with work ability.

One finds pleasure in a job is susceptible to stay because the work ability is satisfactory. Cheung and Tang (2009) argued that quality of work life had partially mediated the relationship between surface acting and work-to-family interference. It was also found that quality of work life correlated negatively with surface acting, but positively with deep acting and expression of natural felt emotions at work (Sisley & Smollan, 2012). Employees who engaged in surface acting had greater tendencies to devalue themselves, experience fewer positive emotions, heighten the level of stress at work (Song & Liu, 2010), use more effort in faking or suppressing their emotions, relates to lowered job satisfaction and poorer psychological health (Grandey, 2003). Employees who engaged in deep acting would contribute to better job and health outcome; fulfill organizationally prescribed emotional display without sacrificing their

sense of authenticity (Blau, Bentley, & Eggerichs-Purcell, 2012). Expression of naturally felt emotions represented employees' autonomy over their emotional expression which was also associated with a low level of work stress. In the same way, Walia (2012) explained that segmentation principle viewed the relationship between work and home as segmented and independent and do not affect each other. The segmentation of work and home is a natural process for workers in unsatisfying jobs (Bauder, 2001).

Mausbach, et.al (2008) shared that developing the capacity of others and following a plan consistent with one's vision and mission are needed to do to demonstrate good leadership. Moreover, Johnson (2006) posited that employers who have introduced family friendly working policies report improved morale, commitment and retention of staff, leading to financial savings, improved customer service and the ability to react more effectively to changes in demand. Increasing the scope for flexible working can also help employers recruit and retain people from the widest possible pool of talent (Rabbitts, 2009).

Flexibility in working opportunities provides people to control the pressures in the different stages of life. So, to have a maintaining family and career balance, Sheel et al., (2012) posited that the time and energy consumed at work must commensurate to the time and energy devoted to life, thus maintaining family and career balance. Cascio (2003) analyzed, the efforts must be aimed at enhancing the overall quality of life and shifting the focus from work to life and from balance to quality. Also, Chao et al., (2002) explored the relationship between leadership behaviour of the principal and quality of work life of

teachers was strong positive in substance; and, teachers' quality of work life could forecast with the principal's leadership behaviour.

Studies revealed indicators of poor quality of work life. These indicators are distinct that some principals tend to resist changes initiated by teachers and other education stakeholders for uneducated reasons such as to prevent having their weaknesses exposed (Marsh & Willis, 2007); socio-economic background of the employees and their expectations in the work place have no significant relationship (Okpara, 2004); and, low level of well-being at work (Worrall and Cooper, 2006). In addition, Dragani (2012) claimed that work quality and productivity are reduced without any doubt when school leaders are pessimistic toward their work and feel the lack of fulfillment in doing their tasks.

Others are very specific on the factors that reinforced poor quality of work life. In the Philippines, Sison (2000) argued that low salaries, poor working conditions, and unequipped managerial skills of most public school principals remain unattended in both research and professional development programs. In addition, The Mindanao Examiner (2007) reported that the education crisis haunting the Philippines is partly due to the deplorable working conditions and substandard pay of public school teachers.

The scarcity of investigations in terms of quality of work life of school heads provoked the researcher to conduct a study on the structural model of strategic, collaborative, and cultural leadership on quality of work life of school heads. This can help to improve the undesirable quality of work life school heads which in turn exude the habit of a progressive administration.

## STATEMENT OF THE PROBLEM

The purpose of the study was to determine the structural model that best fits on quality of work life among school heads.

Specifically, it answers the following questions:

1. What is the level of strategic leadership of school heads in terms of:
  - 1.1. awareness,
  - 1.2. planning,
  - 1.3. development,a
  - 1.4 results, and
  - 1.5. culture?
2. What is the level of collaborative leadership of school heads in terms of:
  - 2.1. assessing the environment,
  - 2.2. visioning and mobilizing,
  - 2.3. building trust,
  - 2.4. sharing power and influence,
  - 2.5. developing people, and
  - 2.6. self-reflection?

3. What is the level of cultural leadership of school heads in terms of:

- 3.1. parental involvement,
- 3.2. teacher involvement,
- 3.3. principal-teacher involvement,
- 3.4. student involvement,
- 3.5. social justice, and
- 3.6. teachers supported?

4. What is the level of the quality of work life of school heads in terms of:

- 4.1. job,
- 4.2. family, and
- 4.3. environment?

5. Is there a significant relationship between strategic leadership of school heads and their quality of work life?

6. Is there a significant relationship between collaborative leadership of school heads and their quality of work life?

7. Is there a significant relationship between cultural leadership of school heads and their quality of work life?

8. Which variable best predicts school heads' quality of work life?

9. What structural model that best fits on quality of work life of school heads?

## METHODOLOGY

### Research Design

The study utilized descriptive-correlation method. The level of strategic, collaborative and cultural leadership and quality of work life was determined. Also, the relationship between strategic, collaborative and cultural leadership of school heads and their quality of work life was determined. The causal relationship method of research was also employed in this study. A stepwise multiple-linear regression analysis was used to determine the extent of influence of strategic, collaborative, and cultural leadership on quality of work life of school heads. Thus, enable to identify the variable that best predicts quality of work life. A structural equation modeling was used to develop a causal model that best fits to the quality of work life and to assess the interrelationships between construct variables in hypothesized manner.

### Research Respondents

The respondents of this study were the 340 teachers in Region XI Southern Mindanao. They determined the causal relationship between the collaborative, strategic, cultural leadership towards quality of work life by means of the questionnaire administered to them, which in turn, explore the structural model that best fits on the quality of work life of school heads

Table 1 showed the distribution of respondents from the ten schools division of Region XI. Respondents

from the ten schools division of Region XI. Respondents from the Division of Davao City were not part of this study due to the reply of the request letter of one of the researchers of this group which she was not given the permission to conduct the study. This made the researcher not to submit his request letter and at the same time to avoid time constraint in the gathering of data.

TABLE I. DISTRIBUTION OF RESPONDENTS

Division	Number of Schools	Percentage	Number of Sample Schools	Number of Respondents
Compostela Valley	324	20	8	80
Davao City	285	17	-	-
Davao del Norte	171	10	4	40
Davao del Sur	387	24	10	100
Davao Oriental	159	10	4	40
Digos City	36	2	1	10
IGACOS	51	3	1	10
Mati City	149	9	4	40
Panabo City	44	3	1	10
Tagum City	29	2	1	10
Total	1635	100	34	340

Research Instrument

The study used four sets of adopted instruments from various authors. These were contextualized to the local setting and validated. These are Collaborative Leadership Questionnaire (Turning Point National Program Office, 1997), Strategic Leadership Questionnaire (Northup, 2012), Cultural Leadership Questionnaire (Glanz, 2006), Quality of Work Life Questionnaire (Niosh, 2012). All of the instruments applied a Five-Point Likert Scale to interpret the level of scores.

IV. FINDINGS

Level of Strategic Leadership of School Heads

The level of strategic leadership of school heads was measured through a survey questionnaire adopted from Northup (2012) with the following indicators: awareness, planning, development, results, and culture. The data revealed that the overall mean for the level of strategic leadership of school heads is 4.32, described as high which means that the behavior is manifested in most of the time by the school heads. This means that the school heads in Region XI show high strategic leadership. They express a strategic vision for the organization and persuade others to acquire that vision.

Table II. LEVEL OF STRATEGIC LEADERSHIP OF SCHOOL HEADS

Item	Mean	Descriptive Level
Awareness	4.38	High
Planning	4.37	High
Development	4.30	High
Results	0.31	High
Culture	4.26	High
Overall	4.32	High

Level of Collaborative Leadership of School Heads

The level of collaborative leadership of school heads was measured through a survey questionnaire adopted from Turning Point National program Office (1997) with the following indicators: assessing the environment, visioning and mobilizing, building trust, sharing power and influence, developing people, and self-reflection. The data revealed that the overall mean for the level of collaborative leadership of school heads is 4.33, described as high which means that the behavior is manifested in most of the time by the school heads. This also means that school heads in Region XI show high collaborative leadership. They accept the responsibility for building a heterogeneous team to accomplish a shared purpose.

Table III. LEVEL OF COLLABORATIVE LEADERSHIP OF SCHOOL HEADS

Item	Mean	Descriptive Level
Assessing the Environment	4.29	High
Visioning and Mobilizing	4.35	High
Building Trust	4.35	High
Sharing and Influence	4.34	High
Developing People	4.35	High
Self-Reflection	4.31	High
Overall	4.33	High

### Level of Cultural Leadership of School Heads

The level of cultural leadership of school heads was measured through a survey questionnaire adopted from Glanz (2006) with the following indicators: parental involvement, teacher involvement, principal-teacher involvement, student involvement, social justice, teachers supported, positive school climate, risk-taking strategies, team approach, and problem-solving strategies. The data revealed that the overall mean for the level of cultural leadership of school heads is 3.61, described as high which means that the behavior is manifested in most of the time by the school heads. This means that the school heads in Region XI show high cultural leadership. They sustain positive climate and culture that examine their own beliefs and values and identify what they deem to be sound and nurturing school culture.

TABLE IV. LEVEL OF CULTURAL LEADERSHIP OF SCHOOL HEADS

Item	Mean	Descriptive Level
Parental Involvement	3.71	High
Teacher Involvement	3.70	High
Principal-teacher Relationship	3.11	Moderate
Student Involvement	3.63	High
Social Justice	3.69	High
Teachers Supported	3.73	High
Positive School Climate	3.57	High
Risk-taking Strategies	3.67	High
Team Approach	3.64	High
Problem-Solving Strategies	3.62	High
Overall	3.61	High

### Level of Quality of Work Life of School Heads

The level of quality of work life of school heads was measured through a survey questionnaire adopted from Niosh (2002) with the following indicators: job, family, and environment. This indicates that there is consistency of responses among the respondents of the study. The data in Table 5 revealed that the overall mean for the level of quality of work life of school heads is 4.36, described as high which means that the behavior is manifested in most of the time by the school heads. This means that the school heads in Region XI show high quality of work life. They have the responsibility to provide congenial environment.

TABLE V. LEVEL OF QUALITY OF WORK LIFE OF SCHOOL HEADS

Item	Mean	Descriptive Level
Job	4.46	High
Family	4.13	High
Environment	4.49	High
Overall	4.36	High

### Significance on the Relationship Between Strategic Leadership of School Heads and Quality of Work Life

The data in Table 6 shows the relationship of Strategic Leadership of School Heads as independent variable with the Quality of Work Life as dependent variable. It can be gleaned in the result that strategic leadership is significantly related to quality of work life as reflected by the p-value that is less than 0.05 and correlation coefficient,  $r = 0.813$ . This implies that high strategic leadership of school heads would essentially increase the quality of work life. The null hypothesis stating, there is no significant relationship between strategic leadership of school heads and quality of work life, is rejected. This suggests that those school heads that have high strategic leadership are more likely to have high quality of work life than those who have low level of strategic leadership.

TABLE VI. SIGNIFICANCE ON THE RELATIONSHIP BETWEEN STRATEGIC LEADERSHIP OF SCHOOL HEADS AND QUALITY OF WORK LIFE

Strategic Leadership	Quality of Work Life			
	Job	Family	Environment	Overall
Awareness	.633* (.000)	.436* (.000)	.673* (.000)	.678* (.000)
Planning	.700* (.000)	.486* (.000)	.715* (.000)	.741* (.000)
Development	.703* (.000)	.402* (.000)	.603* (.000)	.662* (.000)
Results	.673* (.000)	.442* (.000)	.579* (.000)	.661* (.000)
Culture	.683* (.000)	.485* (.000)	.738* (.000)	.742* (.000)
Overall	.793* (.000)	.526* (.000)	.771* (.000)	.813* (.000)

\*significant at .05 significance level

Significance on the Relationship Between Collaborative Leadership of School Heads and Quality of Work Life

Similarly, Table 7 shows the relationship between collaborative leadership of school heads and the quality of work life which is found to be significant with a p-value less than 0.05, and  $r = 0.808$ . This implies that those who are highly collaborative in leading are more likely to have higher quality work life. This yields the rejection of the null hypothesis. The findings indicate that the deeper the school heads manifest collaborative leadership, the more likely they successfully have quality work of life. The findings also suggest that to acquire a deeper essence of collaborative leadership, the school heads must master its six sub-constructs.

TABLE VII. SIGNIFICANCE ON THE RELATIONSHIP BETWEEN COLLABORATIVE LEADERSHIP OF SCHOOL HEADS AND QUALITY OF WORK LIFE

Collaborative Leadership	Quality of Work Life			
	Job	Family	Environment	Overall
Assessing the Environment	.678* (.000)	.448* (.000)	.712* (.000)	.714* (.000)
Visioning and Mobilizing	.749* (.000)	.492* (.000)	.671* (.000)	.745* (.000)
Building Trust	.702* (.000)	.463* (.000)	.670* (.000)	.715* (.000)
Sharing Power and Influence	.693* (.000)	.418* (.000)	.670* (.000)	.691* (.000)
Developing People	.727* (.000)	.496* (.000)	.757* (.000)	.771* (.000)
Self-Reflection	.650* (.000)	.469* (.000)	.732* (.000)	.721* (.000)
Overall	.779* (.000)	.517* (.000)	.781* (.000)	.808* (.000)

\*significant at .05 significance level

Significance on the Relationship Between Cultural Leadership of School Heads and Quality of Work Life

Table 8 shows a significant relationship between Cultural Leadership of School Heads and Quality of Work Life as reflected by the p-value that is less than 0.05 and correlation coefficient,  $r = 0.645$ . This means that high cultural leadership of school heads would essentially increase the quality of work life. This connotes that the null hypothesis is rejected. This conveys further that the less the school heads manifest cultural leadership, the less they could be successful in quality of work life.

TABLE VIII. SIGNIFICANCE ON THE RELATIONSHIP BETWEEN CULTURAL LEADERSHIP OF SCHOOL HEADS AND QUALITY OF WORK LIFE

Cultural Leadership	Quality of Work Life			
	Job	Family	Environment	Overall
Parental Involvement	.465* (.000)	.301* (.000)	.627* (.000)	.538* (.000)
Teacher Involvement	.453* (.000)	.328* (.000)	.668* (.000)	.561* (.000)
Principal-Teacher Involvement	.211* (.000)	.189* (.001)	.210* (.000)	.241* (.000)
Student Involvement	.524* (.000)	.386* (.000)	.549* (.000)	.570* (.000)
Social Justice	.523* (.000)	.305* (.000)	.551* (.000)	.533* (.000)
Teachers Supported	.539* (.000)	.328* (.000)	.607* (.000)	.571* (.000)
Positive School Climate	.497* (.000)	.376* (.000)	.452* (.000)	.519* (.000)
Risk-taking Strategies	.526* (.000)	.304* (.000)	.533* (.000)	.528* (.000)
Team Approach	.460* (.000)	.337* (.000)	.581* (.000)	.536* (.000)
Problem Solving Strategies	.419* (.000)	.310* (.000)	.467* (.000)	.467* (.000)
Overall	.587* (.000)	.406* (.000)	.665* (.000)	.645* (.000)

\*significant at .05 significance level

Significance on the Influence of Strategic, Collaborative and Cultural Leadership of School Heads on the Quality of Work Life

With the presence of regression, the researcher would like to examine deeply if there are possible direct and indirect relationship. When quality of work life of teachers was regressed on the strategic, collaborative, and cultural leadership, it generated an  $R^2$  of 0.704 as shown in Table 9. The ANOVA value of this regression is 258.671 significant at 0.000. It can be stated therefore that the combination of the three independent variables significantly influenced quality of work life of school heads. The  $R^2$  of 0.704 indicates that 70.4% of the variance in quality of work life of school heads is attributed to strategic, collaborative, and cultural leadership. This means that 29.6% of the variation in quality of work life is attributed to other variables not covered in this study. Examining further, the table shows that among the three independent variables, strategic leadership has the greatest contribution (Beta = 0.447, p-value = 0.000), followed by collaborative leadership (Beta =

0.362, p-value = 0.000) and the lowest is cultural leadership with Beta 0.074, p-value = 0.104.

Table IX. SIGNIFICANCE ON THE INFLUENCE OF STRATEGIC, COLLABORATIVE, AND CULTURAL LEADERSHIP OF SCHOOL HEADS ON THE QUALITY OF WORK LIFE

Model	R	R Square	Adjusted R Square	Std. Error of the
1	.839 <sup>a</sup>	.704	.701	.29631

Model	Sum of Square	df	Mean Square	F	Sig.
1	68.135	3	22.712	258.671	.000 <sup>a</sup>
Residual	96.758	329	.088		

Model	Standardized Coefficients (Beta)	t	Sig.
1 (Constant)		4.210	.000
Strategic Leadership	.447	7.241	.000
Collaborative Leadership	.362	5.252	.000
Cultural Leadership	.074	1.632	.104

Test of Hypothesized Model 1  
The CULTRA-COLAB-STRATEG-QUALFE Model

The hypothesized model 1 in standardized solution is illustrated in Figure 1. In this model, 90% variance is explained by the combined influence of strategic leadership, collaborative leadership, and cultural leadership. It can be gleaned that the latent variable collaborative leadership is strongly represented by building trust (Beta = 0.91). On the other hand, principal-teacher relationship appeared to be the weakest factor representing the latent variable, cultural leadership (Beta = 0.32).

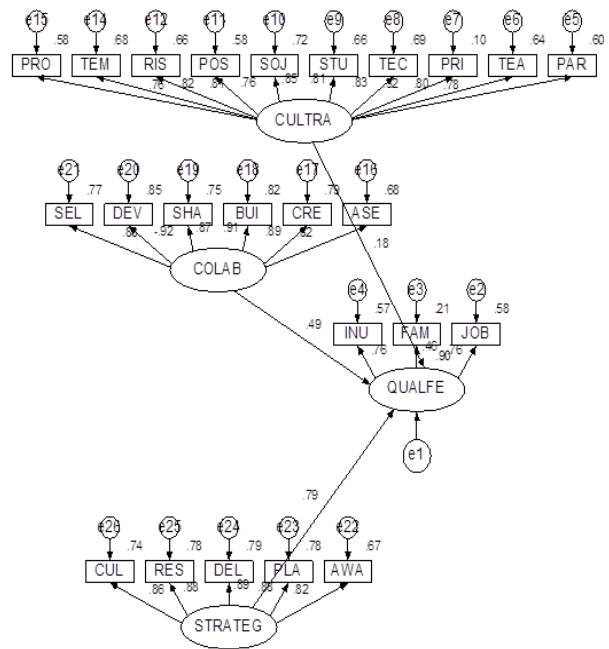

Figure 1. Structural Model Standardized Solution of Strategic, Collaborative, Cultural Leadership and Quality of Work Life

- Legend:
- PRO – Problem-solving Strategies
  - TEM – Team Approach
  - RIS - Risk-taking Strategies
  - POS – Positive School Climate
  - SOJ – Social Justice
  - STU – Student Involvement
  - TEC – Teachers Supported
  - PRI – Principal-teacher Relationship
  - TEA – Teacher Involvement
  - PAR – Parental Involvement
  - CULTRA – Cultural Leadership
  - SEL – Self-Reflection
  - DEV – Developing People
  - SHA – Sharing Power and Influence
  - BUI – Building Trust
  - CRE – Creating Clarity
  - ASE – Assessing the Environment
  - COLAB – Collaborative Leadership
  - INU – Environment
  - FAM - Family
  - JOB – Job
  - QUALFE – Quality of Work Life
  - CUL – Culture
  - RES - Result
  - DEL – Development
  - PLA - Planning
  - AWA – Awareness
  - STRATEG – Strategic Leadership

Test of Hypothesized Model 2  
The CULTRA-COLAB-STRATEG-QUALFE Model

Figure 2 displays a model showing the interrelationship between the exogenous variables such as strategic leadership, collaborative leadership, and cultural leadership and its causal relationship on quality of work life. As reflected in the model, a total of 95% variations in the quality of work life can be attributed to the combined influence of strategic leadership, collaborative leadership, and cultural leadership. It was also shown in the model that strategic leadership, collaborative leadership, and cultural leadership are strongly represented by their factors with the Beta values that are greater than 0.70. Meanwhile, the strategic leadership (Beta = 0.69), collaborative leadership (Beta = 0.20), cultural leadership (Beta = 0.12) provided significant direct effect on quality of work life. Moreover, the latent collaborative leadership is positively correlated with strategic leadership and is also positively correlated to cultural leadership.

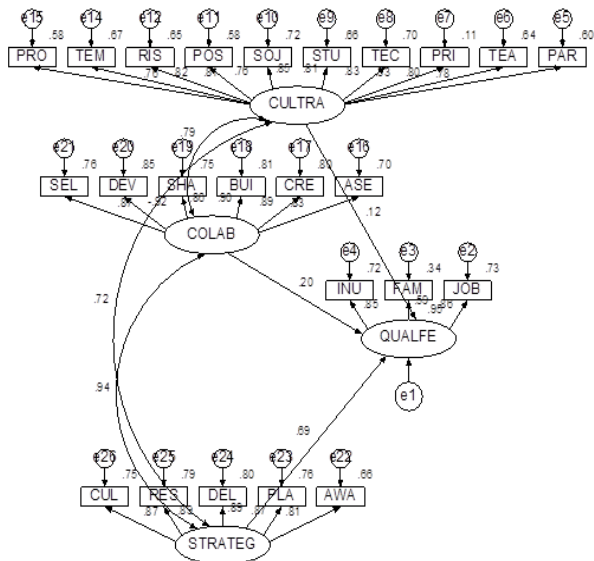

Figure 2. A Model Showing the Interrelationship Between the Exogenous Variables: Strategic, Collaborative and Cultural Leadership and its Causal Relationship on Quality of Work Life

- Legend:
- PRO – Problem-solving Strategies
  - RIS - Risk-taking Strategies
  - SOJ – Social Justice
  - TEM – Team Approach
  - POS – Positive School Climate
  - STU – Student Involvement

- TEC – Teachers Supported
- TEA – Teacher Involvement
- CULTRA – Cultural Leadership
- DEV – Developing People
- BUI – Building Trust
- ASE – Assessing the Environment
- INU – Environment
- JOB – Job
- CUL – Culture
- DEL – Development
- AWA – Awareness
- PRI – Principal-teacher Relationship
- PAR – Parental Involvement
- SEL – Self-Reflection
- SHA – Sharing Power and Influence
- CRE – Creating Clarity
- COLAB – Collaborative Leadership
- FAM - Family Quality of Work Life
- RES - Result
- PLA - Planning
- STRATEG – Strategic Leadership

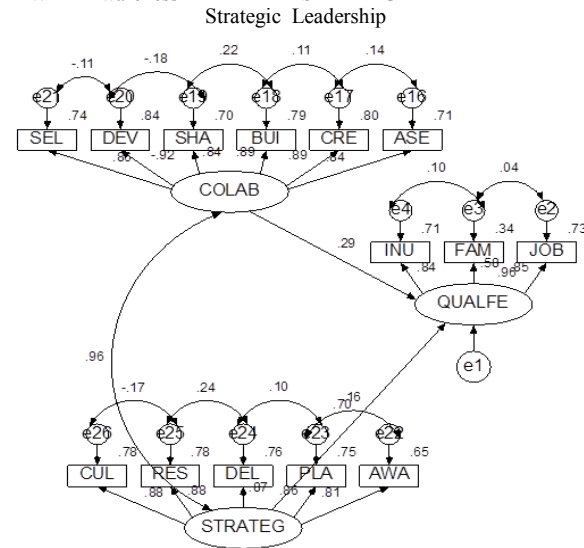

Figure 7. Structural Model Standardized Solution of Collaborative and Strategic Leadership towards Quality of Work Life

- Legend:
- SEL – Self-Reflection
  - DEV – Developing People
  - SHA – Sharing Power and Influence
  - BUI – Building Trust
  - CRE – Creating Clarity
  - ASE – Assessing the Environment
  - COLAB – Collaborative Leadership
  - FAM – Family Quality of Work Life
  - RES – Result
  - DEL - Development
  - PLA – Planning
  - STRATEG – Strategic Leadership
  - INU - Environment
  - JOB - Job
  - CUL - Culture
  - DEL - Development
  - AWA - Awareness



Test of Hypothesized Model 4  
The COLAB-QUALFE Model

Figure 4 shows the structural model standardized solution of collaborative leadership on quality of work life. Results indicate that the latent variable collaborative leadership representing the measured variables assessing the environment, creating clarity, building trust, sharing power and influence, developing people, and self-reflection have significant contribution to the latent variable quality of work life. This is clear with the explained variance of collaborative leadership on quality of work life by 96%. It can also be gleaned from the figure that five out of six factors of collaborative leadership have strong interconnect- edness with each other with the Beta > 0.80.

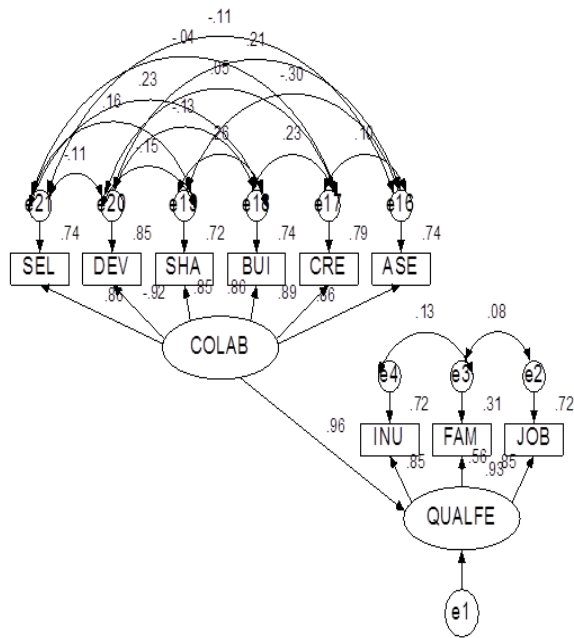

Figure 4. A Structural Model Standardized Solution of

Collaborative Leadership on Quality of Work Life

- Legend:
- |                                   |                                 |
|-----------------------------------|---------------------------------|
| SEL – Self-Reflection             | DEV – Developing People         |
| SHA – Sharing Power and Influence | BUI – Building Trust            |
| CRE – Creating Clarity            | ASE – Assessing the Environment |
| COLAB – Collaborative Leadership  | INU – Environment               |
| FAM – Family                      | JOB - Job                       |

QUALFE – Quality of Work Life e – Error Variables

Table X. SUMMARY AND DISCUSSION OF THE FINDINGS ON THE HYPOTHESIZED STRUCTURAL MODELS

In terms of the research question relate to the model that best represents the variables that predict quality of work life of school heads, the original proposed model outlined in Figure 1 needed some modification in order to fit the data. There were four structural models presented in the study. The summary of the findings of the goodness of fit measures of these four structural models is presented in Table 10.

In identifying the best fitting model, all the indices included must consistently fall within acceptable ranges. Chi-square / degrees of freedom value should between 0 and 2, with its corresponding p-value greater or equal to 0.05. Root Mean Square of Error Approximation value must be less than 0.05 and its corresponding pclose value must be greater or equal to 0.05. The other indices such as Normed Fit Index, Tucker-Lewis Index, Comparative Fit Index, and Goodness of Fit Index must be all greater than 0.90.

Hypothesized Structural Model 1 considered only the direct effects of strategic, collaborative, and cultural leadership towards quality of work life. Two of the indices of this model namely, CMIN/DF = 7.076 with its p-value = 0.000 and RMSEA = 0.136 with pclose = 0.000 did not reach the criteria, thus, indicate a poor fit.

Hypothesized Structural Model 2 includes the interrelationship among strategic, collaborative, and cultural leadership and their causal relationships towards quality of work life. The model was still found poor fit as reflected by the CMIN / DF = 3.949 with its p-value = 0.000 and RMSEA = 0.095 with pclose = 0.000, all did not fall to the acceptable ranges.

Hypothesized Structural Model 3 considers the relationship between collaborative and strategic leadership and their direct effect n quality of work life. The model was still found non-fitting to the data as indicated by CMIN / DF = 4.277, p-value = 0.000 and RMSEA = 0.100 with pclose = 0.000.

Lastly, Hypothesized Structural Model 4 includes the direct causal relationship of collaborative leadership towards quality of work life. Model 4 was found to have indices that consistently indicate a very good fit to the data as indicated by CMIN/DF = 0.540, p-value = 0.148, RMSEA = 0.018, pclose = 0.894 and indices such as NFI, TLI, CFI, and GFI all greater than 0.90 which fall within each criterion.

The model apparently showed the importance of collaborative leadership as a major pre-

dicator of quality of work life. Collaborative leadership plays a key role for the school heads to carry out quality of work life successfully. Thus, the finding suggests that the quality of work life of school heads is best anchored on their strong evidence of collaborative leadership.

### CONCLUSIONS

The structural model that best fits the quality of work life of school heads is the major objective of this study. Based on the findings, the following conclusions are provided, these are;

- The analysis revealed that strategic, collaborative, and cultural leadership significantly predict the quality of work life. Strategic leadership was shown to be the strongest predictor of quality of work life. The result of the analysis explained that the amount of variance by the independent variable to the dependent variable was 70.4% as indicated by the  $R^2 = 0.704$ .
- Structural Model 1, 2, and 3 did not show a good fit measure to the data. Structural Model 1 which included the direct relationship of strategic leadership, collaborative leadership, cultural leadership towards quality of work life, had fit indices of chi-square/degrees of freedom = 7.076 and RMSEA = 0.136. Model 2 which included the interrelationship between the exogenous variables and its causal relationship to quality of work life had fit indices of chi-square/degrees of freedom = 3.949 and RMSEA = 0.095. Model 3 which included the interrelationship of collaborative and strategic leadership and their direct effect on quality of work life had fit indices of chi-square/degrees of freedom = 4.277 and RMSEA = 0.100. On the other hand, Model 4 which included the direct causal relationship of collaborative leadership towards quality of work life was shown to have a very good fit to the data with the indices chi-square/degrees of freedom = 0.540 and RMSEA = 0.018, all are not significant at the 0.05 level. This indices were consistently supported by the other indices which also passed all the goodness of fit indices such as NFI = 0.984, TLI = 0.960, CFI = 0.988, and GFI = 0.972 which all fall within the acceptable range  $> 0.95$ . Among the four structural models explored in the study, Model 4 appeared to have indices that indicate a very good fit to the data. Thus, Model 4 is the best fitting structural model. This showed that the quality of work life is

best anchored on strong evidence of collaborative leadership.

### RECOMMENDATIONS

Based on the conclusions of the study, the researcher recommends the following:

- It came out that only one good fit model was produced. Thus, it is highly recommended to produce two or more models that may be fit to the same covariance matrix.
- Formulate a policy for creating enabling environment for the practice of Collaborative Leadership-Quality of Work Life Model for it to be successful.
- School administrators may employ good type of leadership in the organization. The Collaborative Leadership-Quality of Work Life Model may contribute to forge high quality of work life
- Faculty members may implement Collaborative Leadership-Quality of Work Life training series to uphold sustainability of good quality of work life.
- Community leaders, parents, students and other stakeholders may enter into a collective negotiation agreement to the school administrators to maintain high quality of work life.
- Researchers may conduct similar studies to determine other possible strong predictors of quality of work life among school heads.

Department of Education officials may conduct trainings and seminars that can boost the leadership skills of school heads.

### ACKNOWLEDGMENT

The author would like to thank the teachers for their understanding and never ending support. A big applause also is given to the Schools Division Superintendents of Region XI for the approval in conducting this study. Dr. Edito B. Sumile, College President of Davao Oriental State College of Science and Technology, for approving the fund assistance.

## REFERENCES

- Blau, G., Bentley, M. A., & Eggerichs-Purcell, J. (2012). Testing the impact of emotional labor on work exhaustion for three distinct emergency medical service (EMS) samples. *Career Development International*, 17(7), 626-645. doi: <http://dx.doi.org/10.1108/13620431211283788>
- Brown, P. (2005). The evolving role of strategic management development. *The Journal of Management Development*, 24(3), 209-222. Retrieved from <http://search.proquest.com/docview216357153?accountid=31259>
- Castillo, J.J. (2009). *Stratified sampling method*. Retrieved April 7, 2013 from <http://explorable.com/stratified-sampling>
- Chao, C. Y., Huang, Y.L. & Lin, C.W. (2002). The relationship between leadership behavior of a principal and quality of work life of teachers in an industrial vocational high school in Taiwan. Retrieved from <http://conference.nie.edu.sg/paper/converted%20Pdf/ab00352.pdf>.
- Cheung, F. Y., & Tang, C. S. (2009). Quality of work life as a mediator between emotional labor and work family interference. *Journal of Business and Psychology*. 24(3), 245-255. doi: 10.1007/s10869-009-9103-7.pdf.
- Dragani, J. (2012). *Work life balance in the 21<sup>st</sup> century*. Retrieved April 5, 2013 from [http://www.spe.org/twa/print/archives/2012/2012v8n3/11\\_v8n3SoftSkills.pdf](http://www.spe.org/twa/print/archives/2012/2012v8n3/11_v8n3SoftSkills.pdf)
- Glanz, J. (2006). *What every principal should know about cultural leadership*. Thousand Oaks: California Press.
- Grandey, A. A. (2003). When "the show must go on": Surface acting and deep acting as determinants of emotional exhaustion and peer-rated service delivery. *Academy of Management Journal*, 46(1), 86-96. Retrieved from <http://search.proquest.com/docview/199798502?accountid=31259>
- Ilmarenin, J., Huuhtanen, P., Nykyri, E. & Tuomi, K. (2001). *Promotion of work ability, the quality of work and retirement*. Retrieved from <http://ocmed.oxfordjournals.org/content/51/5/318.full.pdf>.
- Johnson, A. (2006). *Success at work protecting the vulnerable workers, supporting good employers: employment Relations Research Series No.50*. Retrieved August 24, 2012 from <http://www.bis.gov.uk/files/file27469.pdf>.
- Key, J. P. (2012). Research design in occupational education. Retrieved April 7, 2013 from <http://www.okstate.edu/ag/aged/cm4h/academic/aged5980a/5980/newpage15.htm>.
- Learning Point Associates (2009). Professional learning communities. Retrieved February 9, 2013 from <http://www.centerforcsri.org/plc/literature.html>
- Marsh, C. & Willis, G. (2007). *Curriculum alternative approaches, ongoing issues*. USA: The Lehigh Press, Inc.
- Mausbach, A. & Mooney N. (2008). *Align the design: a blueprint for school improvement*. United States of America: Association for Supervision and Curriculum Development.
- Niosh, E. (2002). Quality of worklife module: general society survey 2002. Section D. Retrieved August 24, 2012 from <http://www.cdc.gov/niosh/topics/stress/pdfs/QWL2010.pdf>
- Northup, T. (2012). *Leadership management group: building excellence at all levels*. Retrieved August 24, 2012 from <http://www.lmqsuccess.com/sq.htm>.
- Okpara, H. (2004). Reutilization of job context and job content as related to employees quality of working life. *Journal of Organizational Behavior*. 12, 379-386.
- Rabbitts, P. (2009). Flexible working grows up. *Personnel Today*, 22-23. Retrieved from <http://search.proquest.com/docview/229897417?accountid=31259>
- Sisley, R., & Smollan, R. (2012). Emotional labour and self-determination theory: A continuum of extrinsic and intrinsic causes of emotional expression and control. *New Zealand Journal of Employment Relations (Online)*, 37(2), 41-57. Retrieved from <http://search.proquest.com/docview/1323011285?accountid=31259>
- Sison, M. (2000). *Scrounging funds to finance public schools in the Philippines*. Retrieved November 2, 2012 from <http://www.unesco.org/education/wef/en-news/philippines.shtm>.
- Sheel, S., Goel, S., Sindhwani, B., & Pathak, S. (2012). Quality of work life, employee performance and career growth opportunities: a literature Review. *International Journal of Multidisciplinary Research*. 2(2). Retrieved August 24, 2012 from [http://zenithresearch.org.in/images/stories/pdf/2012/Feb/ZIJMR/22\\_ZENVOL2ISSUE2\\_FEB12.pdf](http://zenithresearch.org.in/images/stories/pdf/2012/Feb/ZIJMR/22_ZENVOL2ISSUE2_FEB12.pdf).

- Sisley, R., & Smollan, R. (2012). Emotional labour and self-determination theory: A continuum of extrinsic and intrinsic causes of emotional expression and control. *New Zealand Journal of Employment Relations (Online)*, 37(2), 41-57. Retrieved from <http://search.proquest.com/docview/1323011285?accountid=31259>
- Sison, M. (2000). *Scrounging funds to finance public schools in the Philippines*. Retrieved November 2, 2012 from <http://www.unesco.org/education/wef/en-news/philippines.shtm>.
- Sheel, S., Goel, S., Sindhwani, B., & Pathak, S. (2012). Quality of work life, employee performance and career growth opportunities: a literature Review. *International Journal of Multidisciplinary Research*. 2(2). Retrieved August 24, 2012 from [http://zenithresearch.org.in/images/stories/pdf/2012/Feb/ZIJMR/22\\_ZENVOL2ISSUE2\\_FEB12.pdf](http://zenithresearch.org.in/images/stories/pdf/2012/Feb/ZIJMR/22_ZENVOL2ISSUE2_FEB12.pdf).
- Song, G., & Liu, H. (2010). Customer-related social stressors and emotional exhaustion: The mediating role of surface and deep acting. *Social Behavior and Personality*, 38(10), 1359-1366. Retrieved from <http://search.proquest.com/docview/820622362?accountid=31259>
- The Mindanao Examiner. (2007) *Philippine teachers decry poor working conditions, delay in benefits*. Retrieved November 2, 2012 from <http://zamboangajournal.blogspot.com/2007/10/philippine-teachers-decry-poor-working.html>.
- Turning Point National Program Office, University of Washington (1997). The Turning Point Collaborative Leadership Self- Assessment Questionnaires. Retrieved August 24, 2012 from [http://turningpointprogram.org/Pages/pdfs/lead\\_dev/CL\\_self-assessments\\_lores.pdf](http://turningpointprogram.org/Pages/pdfs/lead_dev/CL_self-assessments_lores.pdf)
- Walia, P. (2012). *Theoretical framework*. Retrieved September 8, 2012 Retrieved from [/bitstream/10603/3692/9/09\\_chapter%.pdf](#).
- Worrall, L. & Cooper, C. L. (2006). *The quality of working life: managers' health and well-being*. Retrieved August 18, 2012 from <http://www.managers.org.uk/research-managers-health-and-well-being-2006>.

# INFLUENCE OF PROFESSIONAL ATTRIBUTES TO SECONDARY SCHOOL TEACHERS' SENSE OF EFFICACY: A STRUCTURAL MODEL

SATURNINO E. DALAGAN, JR.

Director for Student Services  
Institute of Education and Teacher Training  
Davao Oriental State College of Science and Technology  
zithromax78@yahoo.com

SHANEL S. BRABANTE

Teacher, Department of Education  
Macambol National High School  
Division of City of Mati

## ABSTRACT

*This study was conducted to determine the relationship and influence of secondary teachers' sense of efficacy and their professional attributes. It specifically aimed to determine the level of teachers' efficacy and professional attributes; the significant relationship of sense of efficacy and professional attributes; the extent of influence of teacher's efficacy and professional attributes; and the best fit model of influence of teacher's efficacy and teacher's professional attributes using structural equation modeling. All secondary school teachers in Mati North District teachers took part as respondents in the study. From the result, it revealed that teachers have common cognition regarding professional attributes based on their behavioral response. This suggests that the respondents have unity in their cognitive experience with respect to professional attributes in teaching. The level of teachers' sense of efficacy is high in terms of students' engagement, instructional strategies and classroom management. The level also of teachers' professional attributes is high in terms of high regards for teaching, knowledge about the learners, ability in communication and competence in instructional strategies. In the test of relationship between the two variables in the study, results showed that the teachers' sense of efficacy and teachers' professional attributes had no significant relationship. The data is consistent with teachers' sense of efficacy having no effect on teachers' professional attributes. The teachers' indicators of sense of efficacy have the corresponding effect sizes that influenced teachers' professional attributes. The four indicators of the professional attributes have small effect sizes on the three indicators of teachers' sense of efficacy. These effect sizes of the four indicators generally have small influenced toward teachers' sense of efficacy. Furthermore, the sample size of respondent used in the study attained the so called best fit. All parameters estimate have been satisfied, this suggests that the model used in this study has an excellent fit.*

**Keywords-** professional attribute, sense of efficacy, effect size, instructional strategy, structural equation modeling

## INTRODUCTION

Teacher is the most important element in the teaching-learning process. Shaukat & Iqbal (2012) said that professional qualification is very significant for the teaching profession to become more competent and knowledgeable in handling classroom discipline. Maheshwari (2014) believed that there is no system of education which is better than its teacher because the quality of education depends upon the teacher who serves it. In short, the role of the teacher in influencing the future of a society cannot be underestimated since they are practitioners of education who educate the children and youth to become responsible and productive members of society (Taneri, Nayir & Menamara 2014).

In the East Africa, Muzaale (2008) reported that there is poor performance of secondary teachers in Busiro County, Wakiso District as reflected in the

poor results of the students they are teaching. Nabukenya (2010) seconded that there is a decline in teachers' performance in different parts of the country. The study of Catahan (2015) revealed that teacher's effectiveness in terms of professional attributes has become a silent issue in the government initiatives. In Davao Region, the study of Delima (2015) emphasized that poor performance of teachers was seen in Davao Region due to deterioration of the standards of teachers' professional conduct.

Continuing professional development is recognized by Bill & Melinda Gates Foundation of 2010 as a key component in developing and maintaining excellence as a teacher. Likewise, Pianta (2011) believed that through the professional activity of teachers, there is a greater student achievement. Effective teachers are passionate about student outcomes (CAEP, 2014), use regular formative and summative assessment to inform planning and student

progress (Earl, 2003), create a fail-safe environment where all students can learn, thrive, and take risks (Cranton & Carusetta, 2004) and demonstrate measurable dispositions including risk taking, critical thinking skills, and creative problem solving (Ponticell, 2003).

The study of Valazza (2001) pointed out that teachers should aim to put knowledge and skills into practice by having a daring and exploratory attitude towards teaching to make changes to their teaching habits. Liakopoulou (2011) also mentioned that pedagogical knowledge and didactic work are considered essential in teaching qualifications. For effective teaching, Banks, et al, (2015) specified that teachers must be prepared to teach a diverse population of students. A study of Wolk (2002) supported that a strong relationships with the students help to decrease discipline problems. In this, Stronge, et al (2011) founded that social interactions between the teacher and students encourage learning and achievement.

Communication skills are vital for anyone who has a teaching job (Rubio, 2009). All teachers need to be skilled in this area to be able to excel in their profession (Merlino, et al, 2014). Similarly, effective teachers are always effective communicators (Frymier & Houser, 2009) who can take something complex and present it in a way that can be absorbed easily by the students (Prozesky, 2000).

Due to the lack of information to measure teachers' professional attribute, this study attempts to further develop new body of knowledge to the available research findings. Relatively, due to the limited information about utilization of causal model and its influence to professional attributes, this also tries to bridge the gap by highlighting and targeting sense of efficacy and professional attributes of teachers which in turn would provide more valuable information that adds as the pillar of educational endeavor.

#### STATEMENT OF THE PROBLEM

The purpose of the study was to determine the relationship and influence sense of efficacy and professional attributes of secondary school teachers.

Specifically, it answers the following questions:

1. What is the level of teachers' professional attributes in terms of:
  - 1.1. high regards for teaching
  - 1.2. knowledge about the learners
  - 1.3. ability in communication competence in instructional strategies?
2. What is the level of teachers' sense of efficacy in terms of:
  - 2.1. students' engagement
  - 2.2. instructional strategies
  - 2.3. classroom management?

3. Is there a significant relationship between professional attributes and sense of efficacy of teachers?

4. What is the extent of influence of professional attributes in the sense of efficacy of teachers'?

5. What is the best fit model of influence of professional attributes to sense of efficacy?

### METHODOLOGY

#### Research Design

The study utilized descriptive-correlation method. The general level of teachers' sense of efficacy and teachers' professional attributes was determined. The test of significance and the use of Cohen's d-family of effect size were used to determine the relationship and influence respectively between teachers' efficacy and teachers' professional attributes. Then, a causal relationship method was used to determine the extent of influence of professional attributes in the sense of efficacy of teachers.

#### Research Respondents

The respondents of this study were the 131 secondary teachers of Mati North District of the City Division of Mati. They determined the general level, relationship and extent of influence of professional attributes in the sense of efficacy of teachers. The sampling techniques used id complete enumeration.

Table 1 showed the distribution of respondents from the ten schools of Mati North District, City Division of Mati.

TABLE I. DISTRIBUTION OF RESPONDENTS

Name of School	Population
Don Enrique National High School	8
Matiao National High School	25
Davao Oriental Regional Science High School	19
Buso National High School	6
Doña Rosa National High School	12
Lawigan National High School	10
Bobon National High School	16
Mayo National High School	13
Don Salvador Lopez National High School	14
Taguibo Agricultural Vocational National High School	8
TOTAL	131

Research Instrument

The research instruments used to gather were adopted from various authors. These were contextualized to the local setting and validated. These are Teacher Sense of Efficacy Scale developed by Tschannen-Moran and Hoy (2001). Teachers Professional Attributes was developed by Barrios (2009). All of the instruments applied a Five-Point Likert Scale to interpret the level of scores.

**FINDINGS**

Level of Teachers' Professional Attributes

Table 2 provides the level of professional attributes of teachers based on four indicators with the overall mean of 4.49 described as high level which means that teachers' professional attributes are felt or observed in most occasions. They have their common cognition regarding professional attributes based on their behavioral response that varied slightly with an average standard deviation of .507 less than one unit.

Table II. LEVEL OF TEACHERS' PROFESSIONAL ATTRIBUTES

Factors	SD	Mean	Descriptive Scale	Level
High regards for teaching	.496	4.58	Always	Very High
Knowledge about learners	.503	4.47	Often	High
Ability to communicate	.503	4.47	Often	High
Competence in instructional strategies	.528	4.44	Often	High
Overall	.507	4.49	Often	High

Level of Teachers' Sense of Efficacy

Table 3 provides the level of teachers' sense of efficacy based on the three indicators with the overall mean of 4.27 described as high which means that teachers' sense of efficacy was manifested most of the time. They have common consensus as evident on their response with small variance, that is, average of 0.456 less than one unit.

Table III. LEVEL OF TEACHERS' SENSE OF EFFICACY

Factors	SD	Mean	Descriptive Scale	Level
Students' engagement	.472	4.25	Quite A Bit	High
Instructional strategies	.483	4.35	Quite A Bit	High
Classroom management	.413	4.21	Quite A Bit	High
Overall	.456	4.27	Quite A Bit	High

Significance on the Relationship Between Professional Attributes and Sense of Efficacy of Teachers

The degree of coefficient of correlation between professional attributes and sense of efficacy of teachers is positive .31. This information suggests that as professional attributes had been observed in most occasion, the teachers' sense of efficacy is in the same behavioral mode. The strength of relationship is considered as medium or moderate. Hence, there is no significant relationship exists. The Cronbach's Alpha is so small from the allowable criterion greater than or equal to .70.

TABLE IV. SIGNIFICANCE ON THE RELATIONSHIP BETWEEN PROFESSIONAL ATTRIBUTES AND SENSE OF EFFICACY OF TEACHERS

Correlation	Sense of Efficacy	Cronbach's alpha
Professional Attributes	.31	.481

\*significant at .05 significance level

Extent of Influence of Professional Attributes in the Sense of Efficacy of Teachers

Figure 1 showed the dynamics of interrelationship among factors of professional attributes and indicators of teachers' sense of efficacy. It can be gleaned that the three factors of the teachers' sense of efficacy have small effect size as the strength of relationship on the four indicators of teachers' professional attributes to sense of efficacy. The students' engagement has an effect size of .224, .223 corresponds to the effect size of instructional strategy, and .157 for classroom management. All of these effect sizes influenced the four indicators of professional attributes.

These four indicators of teachers' professional attributes have the corresponding effect sizes that influenced teachers' efficacy. These are .237 for high regards for teaching, .180 for knowledge about the learners, .182 for the ability to communicate, and .081 for competence instructional strategy. These effect sizes of the four indicators generally have small influenced toward teachers' sense of efficacy, which measured .408.

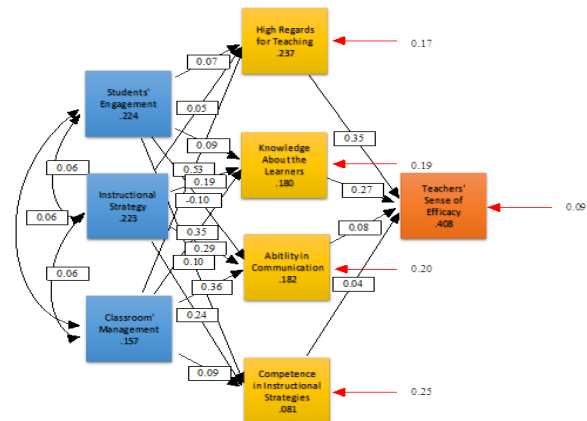

Fig. 1. The Dynamics of Interrelationship among Factors of Professional Attributes and Indicators of Teachers' Sense of Efficacy

Best Fit Model of Influence of Professional Attributes to Sense of Efficacy of Teachers

Suhr (2012) elicited that the Comparative Fit Index (CFI) is equal to the discrepancy function adjusted for sample size. CFI ranges from 0 to 1 with a larger value indicating better model fit. Acceptable model fit is indicated by a CFI value of 0.90 or greater. But if model fit is acceptable, the parameter estimates are examined. If unacceptable model fit is found, the model could be revised when the modifications are meaningful.

Table 5 and table 6 indicate that the sample size of respondent used in the study attained the so called best fit. All parameters estimate indicated from the two tables have been satisfied, this suggests that the model used in this study has an excellent fit.

There are several indicators of goodness-of-fit and most SEM scholars recommend evaluating the models by observing more than one of these indicators (Hoe, 2008). A study of Garver (2009) emphasized that the criteria for ideal fit indices are relative independence of sample size, accuracy and consistency to assess different models, and ease of interpretation aided by a well defined pre-set range. Based on this stated criteria, a paper of Williams (2011) recommended the non-normed fit index (NNFI); the comparative fit index (CFI), and the root mean squared approximation of error (RMSEA). Therefore, the commonly applied fit indices are NNFI and CFI (>0.90 indicates good fit), RMSEA (<0.08 indicates acceptable fit), and commonly used  $\chi^2$  statistic  $\chi^2$ /d.f. ratio of 3 or less (Hooper, 2008).

TABLE V. LEAST SQUARE METHOD FOR GOODNESS OF FIT STATISTICS

Indicator of Goodness of Fit	Value	Remark
Independence Model Chi-square	153.628	Very reasonable fit
Degrees of Freedom	28	Very reasonable fit
Independence AIC	97.628	Very reasonable fit
independence CAIC	6.670	Very reasonable fit
Model AIC	67.272	Very reasonable fit
Model CAIR	38.036	Very reasonable fit
Chi-Square Based on 9 DF	85.272	Very reasonable fit
Probability Value for Chi-square	.00000	Very reasonable fit

TABLE VI. THE FIT INDICES GENERATED FROM EQUATION STRUCTURAL MODEL (PATH STRUCTURE)

Fit Indices	Cut-off Value	Value	Remark
Bentler-Bonett Normed Fit Index	Greater than .95	0.989	Passed
Bentler-Bonett Non-Normed Fit Index	Greater than .95	1.18	Passed
Comparative Fit Index (CFI)	Greater than .95	1	Passed
Bollen's (IFI) Fit Index	Greater than .95	1.05	Passed
Mcdonald's (MFI) Fit Index	Greater than .90	1.053	Passed
Joreskog-Sorbom's GFI Fit Index	Greater than .90	0.919	Passed
Joreskog-Sorbom's AGFI Fit Index	Greater than .90	0.674	Passed
Root Mean-Square Residual (RMR)	Less Than .05	0.027	Passed
Root Mean-Square Error of Approximation	Less than .05	0.134	Passed
90% Confidence Interval of RMSEA	90% interval	None	None
Reliability Coefficient (Cronbach's Alpha)	.70	.704	Passed

CONCLUSIONS

The relationship and extent of influence of sense of efficacy and professional attributes of the secondary teachers is the main objective of this study. Based on the findings, the following conclusions are provided,

1. The level of teachers' professional attributes in terms of high regards for teaching, knowledge about the learners, ability in communication and competence in instructional strategies is high.
2. The level of teachers' sense of efficacy in terms of student engagement, instructional strategies, and classroom management is also high.
3. The strength of relationship is considered as medium or moderate. There is a lower likelihood of there being related.
4. There exists a model that best fit in influence of professional attributes to sense of efficacy using structural equation modeling. These indices were consistently supported by the other indices which also passed all the goodness of fit indices. This showed that the professional attributes of teachers is best anchored on strong evidence of sense of efficacy.



## RECOMMENDATIONS

Based on the conclusions of the study, the researchers recommend the following:

- Professional teachers must continue to explore creative ways to afford more time to engage in collaborative professional development activities as this is vital to enhancement of student learning.
- Department of Education officials may conduct in-service trainings and seminars that can boost the professional attributes of teachers to bring about desired outcomes of student performance.
- Researchers may conduct similar studies to determine other possible influence to sense of efficacy. Continuing professional development is highly recommended to further pedagogical contents as major qualification to the teaching profession.

## ACKNOWLEDGMENT

The authors would like to thank the teachers for spending their time answering the questionnaires. Thank you very much to the Schools Division Superintendent of the City Division of Mati for the approval in conducting this study and to Dr. Edito B. Sumile, College President of Davao Oriental State College of Science and Technology, for approving the fund assistance.

## REFERENCES

- Banks, J. A., Cookson, P., Gay, G., Hawley, W. D., Irvine, J. J., Nieto, S., Schofield, J. W., & Stephan, W. G. (2005). Diversity Knowledge, Skills, and Dispositions. Missouri State University. Retrieved April 13, 2015, from: <http://www.missouristate.edu/epp/46989.htm>.
- Barrios, M.M. (2009). Teachers Professional Characteristics and Fellowship in Relation to Work Behavior in State Colleges and Universities in Region XI. Unpublished Thesis.
- Bill & Melinda Gates Foundation. (2010). Empowering excellent teachers. Strategies for implementing reforms. Retrieved from <http://www.gatesfoundation.org>.
- Catahan, M. (2015). Enhancing Competency of Teachers: A Teaching-and-Learning Enhancement Guide. Retrieved from <https://books.google.com.ph/books?id=EtnICQAAQBAJ&pg=PT62&lpg=PT62&dq=professional+attrib>
- utes+of+the+Filipino+teachers.
- Council for the Accreditation of Educator Preparation. (2014). . CAEP evidence guide version 1.0. Retrieved from [http://caepnet.files.wordpress.com/2014/02/caep\\_evidence\\_guide1.pdf](http://caepnet.files.wordpress.com/2014/02/caep_evidence_guide1.pdf).
- Cranton, P. & Carusetta, E. (2004). Perspectives on Authenticity in Teaching, Education & Educational Research 105 out of 224. Retrieved <http://aeq.sagepub.com/content/55/1/5.abstract>.
- Delima, V. T. (2015). Professional Identity, Professional Commitment and Teachers' Performance. International Journal of Novel Research in Education and Learning. Novelty Journals. Vol. 2, Issue 4, pp: (1-12). Retrieved from <https://www.google.com.ph/url?>
- Earl, L., 2003. Assessment as Learning: Using classroom assessment to maximize student learning. Corwin Press, INC.
- Frymier, A. B., & Houser, M. L. (2009). The teacher-student relationship as an interpersonal relationship. Communication Education. Vol. 49. Issue 3. Retrieved April 13, 2016 from <http://www.tandfonline.com/doi/abs/10.1080/03634520009379209>.
- Garver, M. (2009). Examining A Model Of Understanding Customer Value And Satisfaction Data. Retrieved April 16, 2016, from <http://www.mmaglobal.org/publications/MMJ/MMJ-Issues/2009-Spring/MMJ-2009-Spring-Vol19-Issue1-Garver-Williams-pp113-132.pdf>
- Hoe, S. L. (2008). Issues and Procedures in Adopting Structural Equation Modeling Technique. Journal of Applied Quantitative Methods. Vol. 3. Issue. 1. Retrieved April 16, 2016 from <http://jaqm.ro/issues/volume-3.issue-1/pdfs/hoef.pdf>

- Hooper, D., Coughlan, J., & Mullen, M. (2008). Structural Equation Modeling: Guidelines for Determining Model Fit. *Electronic Journal of Business Research Methods*, 6(1), 53-60. Retrieved from <http://arrow.dit.ie/cgi/viewcontent.cgi?article=1001&context=buschmanart>
- Liakopoulou, M. (2011). The Professional Competence of Teachers: Which qualities, attitudes, skills and knowledge contribute to a teacher's effectiveness?. *International Journal of Humanities and Social Science*. Vol. 1 No. 21. Retrieved from: [http://www.ijhssnet.com/journals/Vol\\_1\\_No\\_21\\_Special\\_Issue\\_December\\_2011/8.pdf](http://www.ijhssnet.com/journals/Vol_1_No_21_Special_Issue_December_2011/8.pdf)
- Maheshwari, A. (2014). A Study of Attitude Towards Teaching Profession Of B.Ed. and Special B.T.C. Prospective Teachers. *Global Journal of Multidisciplinary Studies*. Retrieved from <http://gjms.co.in/index.php/gjms/article/viewFile/425/381>
- Merlino, J. P., MD, Saeed, S., Silver, S. Petit, J. R., Moffic, S., MD, Lucey, J., MD, & Moyhuddin, F. (2014). Current Perspectives on Psychiatric Administration and Leadership. *Journal of Psychiatric Administration and Management*. Vol 3. No. 1. Retrieved April 13, 2016, from <http://search.proquest.com/openview/c50a6706c56134b550e3a759250d1d6a/1?pq-origsite=gscholar>
- Muzaale, F. (2008). Kiboga head teachers face demotion over poor results. Retrieved April 13, 2016 from [http://mak.ac.ug/documents/Makfiles/theses/Muzaale\\_2008.pdf](http://mak.ac.ug/documents/Makfiles/theses/Muzaale_2008.pdf).
- Nabukenya, M. (2010). Influence of Teachers' Professionalism on Teacher Performance in Busiro County Secondary Schools, Wakiso District. Retrieved from [http://mak.ac.ug/documents/Makfiles/theses/Nabukenya\\_Margaret.pdf](http://mak.ac.ug/documents/Makfiles/theses/Nabukenya_Margaret.pdf)
- Pianta, R. C. (2011). Teaching children well. New evidence-based approaches to teacher professional development and training. Washington, DC: Center for American Progress.
- Ponticell, J. A. (2003). Enhancers and Inhibitors of Teacher Risk Taking: A Case Study. *Peabody Journal of Education*
- Prozesky, R.D. (2000) "Communication and effective teaching" *Journal of Community Eye Health, International centre for eye health, London, UK.*
- Rubio, C. M. (2009). Effective teachers –Professional and personal skills. Retrieved from [file:///C:/Users/Admin/Downloads/Dialnet-EffectiveTeachersprofesionalAndPersonalSkills-3282843%20\(2\).pdf](file:///C:/Users/Admin/Downloads/Dialnet-EffectiveTeachersprofesionalAndPersonalSkills-3282843%20(2).pdf)
- Shaukat, S., & Iqbal, H. M. (2012). Teacher Self-Efficacy as a Function of Student Engagement, Instructional Strategies and Classroom Management. *Pakistan Journal of Social and Clinical Psychology* 2012, Vol. 10, No 2, 82-85. Retrieved from <http://www.gcu.edu.pk/FullTextJour/PJSCS/2012july/13.pdf>.
- Stronge, J. H., Ward, T. J., & Grant, L. W. (2011). What makes good teachers good? A cross-case analysis of the connection between teacher excellence and student achievement. *Journal of Teacher Education*, 62(4), 339-355.
- Suhr, D. (2006). The Basics of Structural Equation Modeling. University of Northern Colorado. Retrieved from <http://www.lexjansen.com/wuss/2006/tutorials/TUT-Suhr.pdf>.
- Taneri, O. P., Nayir, K. P. & Mcnamara, G. (2014). Teacher Candidates' Attitudes Towards The Teaching Profession – Worrying Trends. *International Periodical For*

The  
Languages, Literature and History of Turkish.  
Volume 9/11  
Fall 2014, p. 529-545. Retrieved from [http://  
www.  
turkishstudies.net/Makaleler/913574185  
32TaneriP.Oya-  
vd-sos-529-545.pdf](http://www.turkishstudies.net/Makaleler/91357418532TaneriP.Oya-vd-sos-529-545.pdf)

Tschannen-Moran M., and Hoy A. W. (2001). Teacher Efficacy capturing elusive construct. *Teaching and Teacher Education* 17 (2001) 783-805. Retrieved from [http://mxtsch.people.wm.edu/Scholarship/  
TATE  
TSECapturingAnElusiveConstruct.pdf](http://mxtsch.people.wm.edu/Scholarship/TATE_TSECapturingAnElusiveConstruct.pdf).

Valazza, G. (n.d). Professional development: teacher development and confidence. Retrieved from [http://  
www.onestopenglish.  
com/ methodology/methodology/professional-  
develop  
ment/professional-development-teacher-  
development-and-  
confidence/146473.article](http://www.onestopenglish.com/methodology/methodology/professional-development/professional-development-teacher-development-and-confidence/146473.article).

Williams, L. J. (2011). Equivalent models: Concepts, problems, alternatives. In *Handbook of Structural Equation Modeling* (R. Hoyle, ed.). Guilford Press, New York, Retrieved from <https://www.academia.edu>.

Wolk, S. (2002). *Being good: Rethinking classroom management and student discipline*. Portsmouth, NH: Heineman







