

**DIMENSIONAL DATA**

---

---

**R-8 COMMERCIAL**

---

---



620 North Post Street • Post Falls, ID 83854 • 208.777.7444 ph 208.777.7445 fax •  
[www.spunstrand.com](http://www.spunstrand.com)

## R-8 (Insulated) Duct and Fittings – Shipping Weights

	1	2	3	4	5	6	7	8	9	10	11	12	13	14	15	16
NOMINAL DIAM. (IN)	STRAIGHT DUCT / FT (lbs)	45° ELBOW (lbs)	90° ELBOW (lbs)	CON. RED. (lbs)	ECC. RED. (lbs)	END CAP (lbs)	TEE (lbs)	SINGLE 45° Y (lbs)	SINGLE 90° Y (lbs)	CROSS (lbs)	DOUBLE 45° Y (lbs)	DOUBLE 90° Y (lbs)	TRUE Y (lbs)	SADDLE TAP (lbs)	TRANSITIO N (lbs)	FLANGE (lbs)
4	2	3	6	2	4	3	3	3	6	3	6	11	3	1	8	3
5	3	3	6	3	4	3	6	6	8	8	8	14	3	1	10	3
6	3	3	6	4	6	3	6	8	11	8	11	17	6	1	11	4
7	4	4	7	6	7	4	6	10	13	10	13	18	6	3	14	4
8	4	6	10	6	7	4	8	11	15	11	15	21	7	3	15	6
9	5	6	11	7	10	4	11	14	21	14	21	32	7	3	17	6
10	5	7	13	7	10	7	13	17	24	15	24	35	10	6	20	7
12	6	10	17	7	10	7	18	23	30	23	30	46	10	6	23	8
14	7	13	23	10	13	8	24	32	39	28	41	55	15	6	27	8
16	8	14	24	11	14	10	25	34	41	31	42	56	17	7	27	8
18	9	17	31	11	15	11	31	44	48	37	52	62	23	7	30	10
20	10	23	39	14	18	15	38	53	66	44	69	79	32	11	37	13
22	11	27	45	18	24	17	44	59	73	51	80	100	35	11	59	20
24	16	32	59	21	28	21	63	91	105	77	113	141	49	15	69	23
26	17	38	68	25	32	21	68	105	127	84	134	162	56	15	75	25
28	18	39	73	28	37	23	73	134	155	91	176	190	68	15	80	27
30	20	45	77	30	38	24	84	148	183	98	183	239	76	17	86	30
32	21	49	111	31	41	25	93	158	200	107	200	257	86	18	93	31
34	24	59	113	33	44	27	114	345	214	131	235	293	100	20	98	33
36	26	69	114	35	46	30	135	214	228	156	270	328	114	21	104	35
38	29	72	125	38	52	34	141	224	243	163	280	353	132	21	108	37
40	31	76	122	41	58	37	147	233	259	170	291	378	150	23	113	38
42	31	83	148	45	58	38	159	253	300	188	312	429	188	23	120	39
44	35	88	156	47	60	35	165	258	305	193	321	436	201	24	124	41
46	37	92	165	49	63	37	170	263	311	198	329	443	212	25	128	42
48	35	101	176	51	66	34	180	273	318	208	346	457	231	25	132	45
54	44	132	239	63	83	44	273	405	463	312	512	648	307	31	141	48
60	54	159	295	70	91	56	346	534	633	394	675	856	338	39	150	51
66	73	246	461	104	135	66	531	848	987	598	1067	1340	645	48	214	72
70	85	304	571	127	163	73	655	1056	1223	734	1329	1662	851	53	115	86
*72	91	333	626	138	179	77	716	1162	1342	804	1461	1824	953	55	280	94

*\*72" and larger diameter ductwork is not included in the ICC-ES listing.*

**OUTSIDE DIAMETER FOR R-8<sup>2</sup> DUCT**  
Tolerance +/- 1/4"

NOMINAL INSIDE DIAMETER (Inches)	INNER WALL		OUTER WALL		OUTSIDE DIAMETER
	# of PLIES	NOM. WALL THICKNESS (Inch)	# of PLIES	NOM. WALL THICKNESS (Inch)	
4	2	0.045	3	0.0675	6.8
5	2	0.045	3	0.0675	7.8
6	2	0.045	3	0.0675	8.8
7	2	0.045	3	0.0675	9.8
8	2	0.045	3	0.0675	10.8
9	2	0.045	3	0.0675	11.8
10	2	0.045	3	0.0675	12.8
12	2	0.045	3	0.0675	14.8
14	2	0.045	3	0.0675	16.8
16	2	0.045	3	0.0675	18.8
18	2	0.045	3	0.0675	20.8
20	2	0.045	3	0.0675	22.8
22	2	0.045	3	0.0675	24.8
24	3	0.0675	4	0.09	27.0
26	3	0.0675	4	0.09	29.0
28	3	0.0675	4	0.09	31.0
30	3	0.0675	4	0.09	33.0
32	3	0.0675	4	0.09	35.0
34	3	0.09	4	0.09	37.0
36	4	0.09	4	0.09	39.0
38	4	0.09	4	0.09	41.0
40	4	0.09	4	0.09	43.0
42	4	0.09	4	0.09	45.0
44	4	0.09	4	0.09	47.0
46	4	0.09	4	0.09	49.0
48	4	0.09	4	0.09	51.0
54	4	0.09	5	0.1125	57.1
60	4	0.90	6	0.135	63.1
66	4	0.09	8	0.18	69.2
70	5	0.1125	9	0.2025	73.4
<b><i>*72" and larger diameter ductwork is not included in the ICC-ES listing.</i></b>					

# Straight Duct

4"  $\phi$  - 48"  $\phi$  L = 20'-0"  
 52"  $\phi$  - 72"  $\phi$  L = 10'-0"

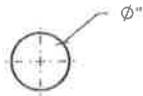
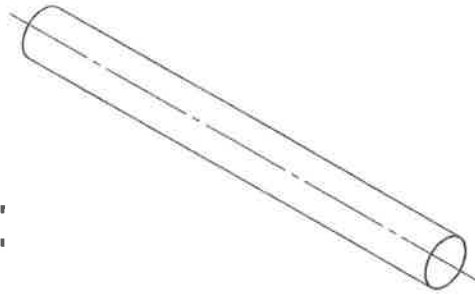

# End Cap

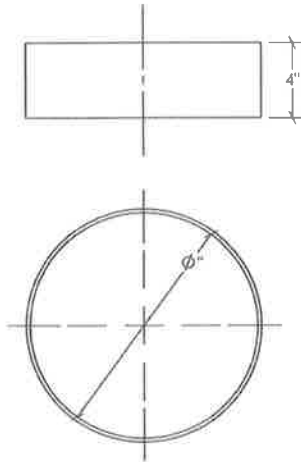
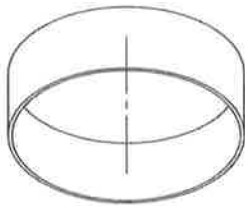

<p><b>PROPRIETARY AND CONFIDENTIAL</b>                  THE INFORMATION CONTAINED IN THIS DRAWING IS THE SOLE PROPERTY OF SPUNSTRAND INC. AND ANY REPRODUCTION IN PART OR AS A WHOLE WITHOUT THE WRITTEN PERMISSION OF SPUNSTRAND INC. IS PROHIBITED.</p>			DIMENSIONS ARE IN INCHES TOLERANCES: FRACTIONAL $\pm$ ANGULAR: MACH $\pm$ BEND $\pm$ TWO PLACE DECIMAL $\pm$ THREE PLACE DECIMAL $\pm$	NAME	DATE	<i>Spunstrand Inc.</i>  <b>Duct</b>	
				DRAWN	CJS		2009
				CHECKED			
				ENG APPR.			
				MFG APPR.			
				Q.A.			
				COMMENTS:			
	NEXT ASSY	USED ON	FINISH				
	APPLICATION		DO NOT SCALE DRAWING				
				MFG	DWG. NO.	Underslab FRP	
						REV.	

*\*72" and larger diameter ductwork is not included in ICC-ES listing.*

### 45° Elbows

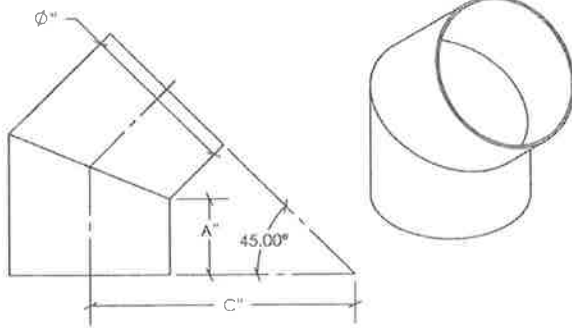

### 90° Elbows

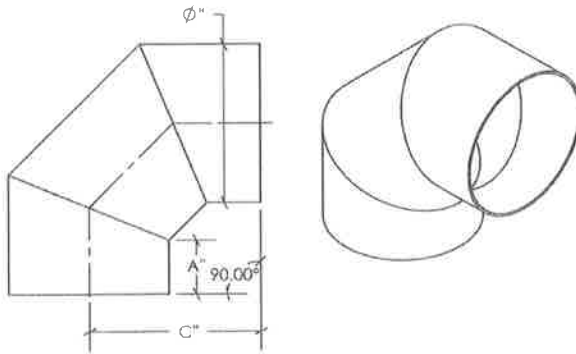

Diameter (in)	90° Elbows		45° Elbows
	A (in)	C (in)	C (in)
4	6	12 3/8	16 5/8
5	6	12 7/8	17 1/8
6	6	13 3/8	17 5/8
7	6	13 7/8	18 1/8
8	6	14 3/8	18 5/8
9	6	14 7/8	19 1/8
10	6	15 3/8	19 5/8
12	6	16 3/8	20 5/8
14	6	17 3/8	21 5/8
16	6	18 3/8	22 5/8
18	6	19 3/8	23 5/8
20	6	20 3/8	24 5/8
22	6	21 3/8	25 5/8
24	6	22 3/8	26 5/8
26	6	23 3/8	27 5/8
28	6	24 3/8	28 5/8
30	6	25 3/8	29 5/8
32	6	26 3/8	30 5/8
34	6	27 3/8	31 5/8
36	6	28 3/8	32 5/8
38	6	29 3/8	33 5/8
40	6	30 3/8	34 5/8
42	6	31 3/8	35 5/8
44	6	32 3/8	36 5/8
48	6	34 3/8	38 5/8
52	6	36 3/8	40 5/8
54	6	37 3/8	41 5/8
60	6	40 3/8	44 5/8
72	6	46 3/8	50 5/8

PROPRIETARY AND CONFIDENTIAL  
THE INFORMATION CONTAINED IN THIS  
DRAWING IS THE SOLE PROPERTY OF  
SPUNSTRAND, INC. AND ANY  
REPRODUCTION IN PART OR AS A WHOLE  
WITHOUT THE WRITTEN PERMISSION OF  
SPUNSTRAND, INC., IS PROHIBITED.

			DIMENSIONS ARE IN INCHES TOLERANCES: FRACTIONAL ± ANGULAR: MACH ± BEND ± TWO PLACE DECIMAL ± THREE PLACE DECIMAL ±	NAME C.J.S.	DATE 2009
			MATERIAL	CHECKED	
			FINISH	ENG APPR.	
NEXT ASSY	USED ON			MFG APPR.	
APPLICATION		DO NOT SCALE DRAWING		Q.A.	
				COMMENTS	

*Spunstrand Inc.*

Elbows

SIZE <b>A</b>	DWG. NO.	Underslab FRP	REV
------------------	----------	---------------	-----

*\*72" and larger diameter ductwork is not included in ICC-ES listing.*

Inches of Reduction	A
1"	2 1/8"
2"	4
3"	5 7/8"
4"	7 3/4"
5"	9 5/8"
6"	11 1/2"
7"	13 3/8"
8"	15 1/8"
9"	17"
10"	18 7/8"
11"	20 3/4"
12"	22 5/8"
13"	24 1/2"
14"	26 3/8"
15"	28 5/8"
16"	32"
17"	33 7/8"
18"	35 3/4"
19"	36 5/8"
20"	37 5/8"

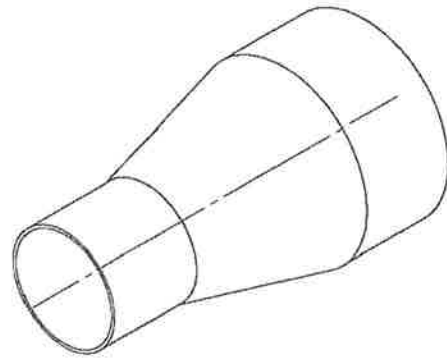

Inches of Reduction =  $D_2 - D_1$

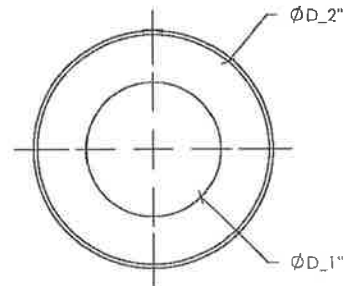
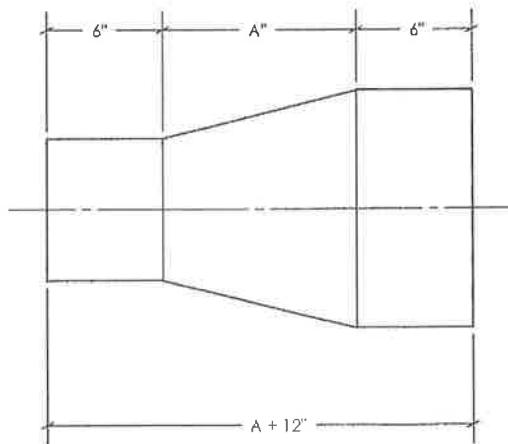

PROPRIETARY AND CONFIDENTIAL  
THE INFORMATION CONTAINED IN THIS  
DRAWING IS THE SOLE PROPERTY OF  
SPUNSTRAND INC. AND ANY  
REPRODUCTION IN PART OR AS A WHOLE  
WITHOUT THE WRITTEN PERMISSION OF  
SPUNSTRAND INC. IS PROHIBITED.

		DIMENSIONS ARE IN INCHES TOLERANCES: FRACTIONAL ± ANGULAR: MACH ± BEND ± TWO PLACE DECIMAL ± THREE PLACE DECIMAL ±	NAME CJS	DATE 2009	<i>Spunstrand Inc.</i>
		MATERIAL	CHECKED		
		FINISH	ENG APPR.		SIZE <b>A</b> DWG. NO. Underslab FRP REV.
NEXT ASSY	USED ON		MFG APPR.		
APPLICATION		DO NOT SCALE DRAWING	COMMENTS:		

Inches of Reduction	A
1"	4 1/4"
2"	8"
3"	11 3/4"
4"	15 1/2"
5"	19 1/4"
6"	23"
7"	26 3/4"
8"	30 1/4"
9"	34"
10"	37 3/4"
11"	41 1/2"
12"	45 1/4"
13"	49"
14"	52 3/4"
15"	57 1/4"
16"	64"
17"	67 3/4"
18"	69 1/4"
19"	71 1/2"
20"	75 1/4"

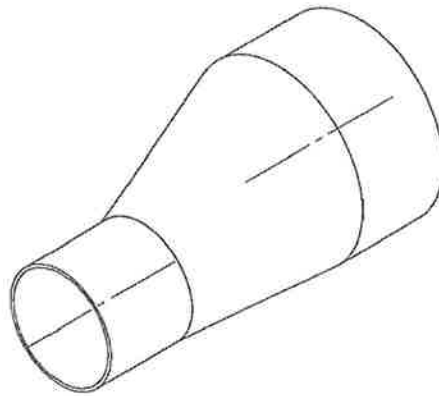

Inches of Reduction =  $D_2 - D_1$

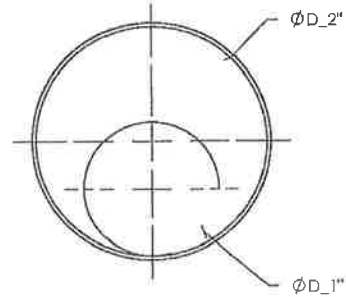
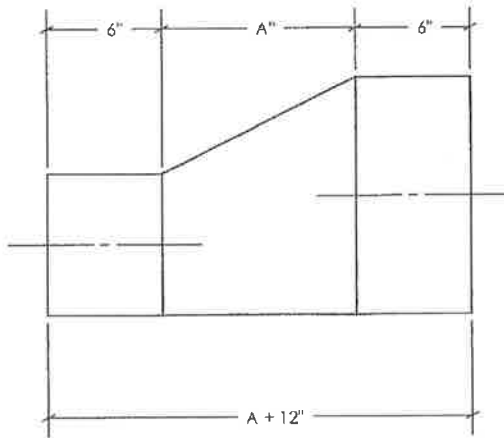

PROPRIETARY AND CONFIDENTIAL  
THE INFORMATION CONTAINED IN THIS  
DRAWING IS THE SOLE PROPERTY OF  
SPUNSTRAND INC. AND ANY  
REPRODUCTION IN PART OR AS A WHOLE  
WITHOUT THE WRITTEN PERMISSION OF  
SPUNSTRAND INC. IS PROHIBITED.

		DIMENSIONS ARE IN INCHES		NAME		DATE		<i>Spunstrand Inc.</i>	
		TOLERANCES:		CJS		2009			
		FRACTIONAL ±		CHECKED				<b>Eccentric Reducer</b>	
		ANGULAR: MACH ± BEND ±		ENG APPR.					
		TWO PLACE DECIMAL ±		MFG APPR.					
		THREE PLACE DECIMAL ±		Q.A.					
		MATERIAL		COMMENTS:					
NEXT ASSY		USED ON		FINISH				SIZE <b>A</b>	
APPLICATION		DO NOT SCALE DRAWING						DWG. NO. Under slab FRP REV.	

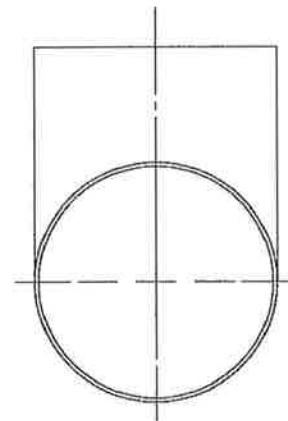
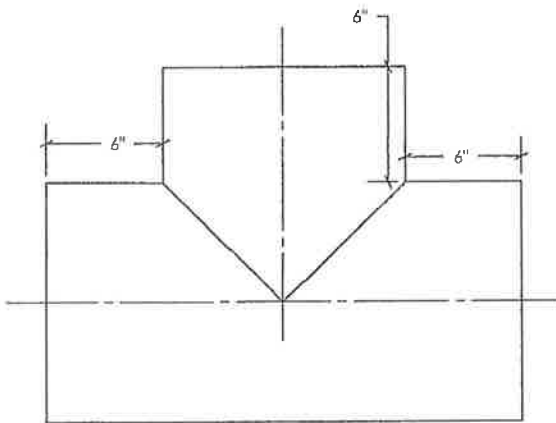
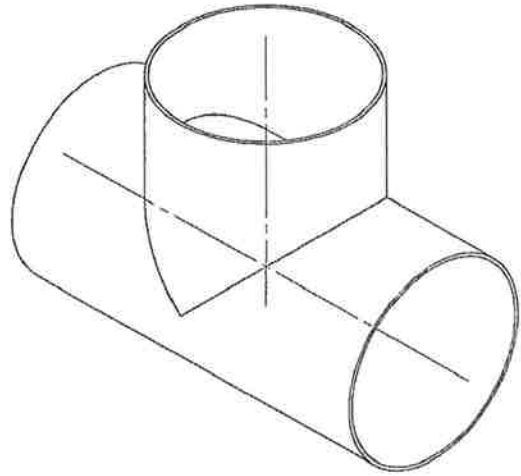
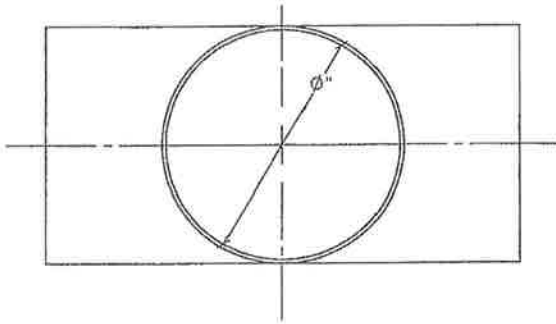

**PROPRIETARY AND CONFIDENTIAL**  
 THE INFORMATION CONTAINED IN THIS DRAWING IS THE SOLE PROPERTY OF SPUNSTRAND INC. AND ANY REPRODUCTION IN PART OR AS A WHOLE WITHOUT THE WRITTEN PERMISSION OF SPUNSTRAND INC. IS PROHIBITED.

		DIMENSIONS ARE IN INCHES		NAME	DATE	<i>Spunstrand Inc.</i>	
		TOLERANCES:		DRAWN	CJS		
		FRACTIONAL ±		CHECKED			TEE
		ANGULAR: MACH ± BEND ±		ENG APPR.			
		TWO PLACE DECIMAL ±		MFG APPR.			
		THREE PLACE DECIMAL ±		Q.A.			SIZE <b>A</b> DWG. NO. <u>Underslab FRP</u> REV.
		MATERIAL		COMMENTS:			
NEXT ASSY	USED ON	FINISH					
APPLICATION		DO NOT SCALE DRAWING					



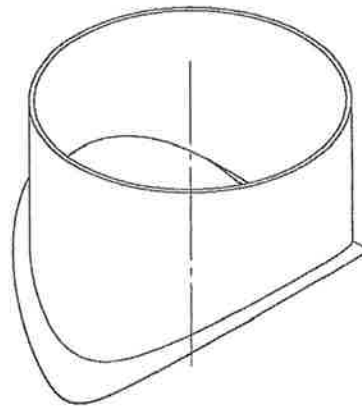
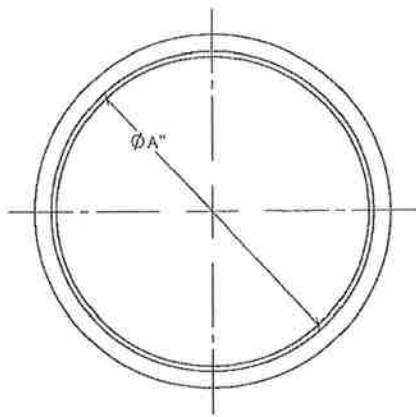

A onto B

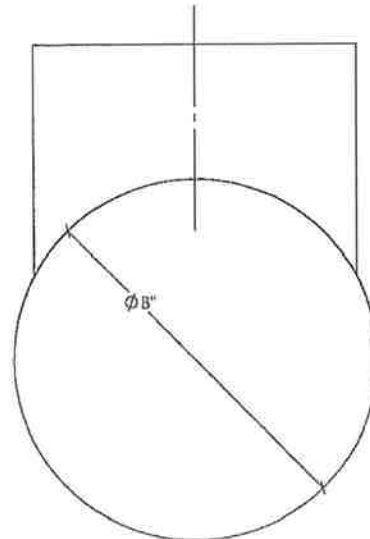
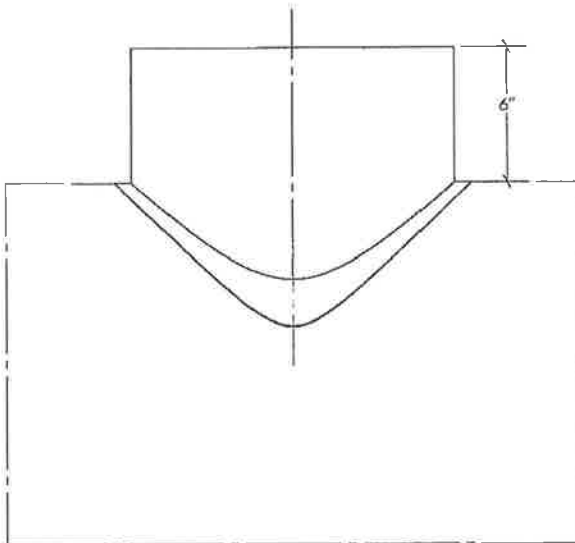

PROPRIETARY AND CONFIDENTIAL  
THE INFORMATION CONTAINED IN THIS  
DRAWING IS THE SOLE PROPERTY OF  
SPUNSTRAND INC. AND ANY  
REPRODUCTION IN PART OR AS A WHOLE  
WITHOUT THE WRITTEN PERMISSION OF  
SPUNSTRAND INC. IS PROHIBITED.

		DIMENSIONS ARE IN INCHES		NAME		DATE		<i>Spunstrand Inc.</i>	
		TOLERANCES:		DRAWN		2009			
		FRACTIONAL ±		CHECKED				<b>90deg Saddle Tap</b>	
		ANGULAR: MACH ± BEND ±		ENG APPR.					
		TWO PLACE DECIMAL ±		MFG APPR.					
		THREE PLACE DECIMAL ±		Q.A.					
		MATERIAL		COMMENTS:				SIZE	
NEXT ASSY	USED ON	FINISH				A		DWG. NO. Underslab FRP	
APPLICATION		DO NOT SCALE DRAWING						REV.	

**A onto B**

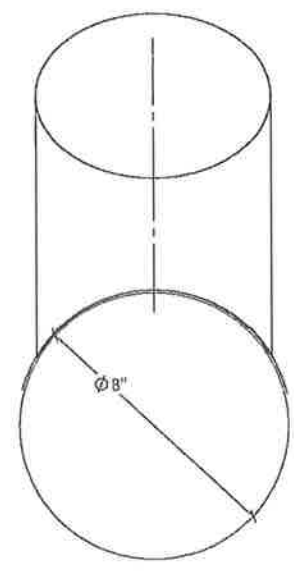
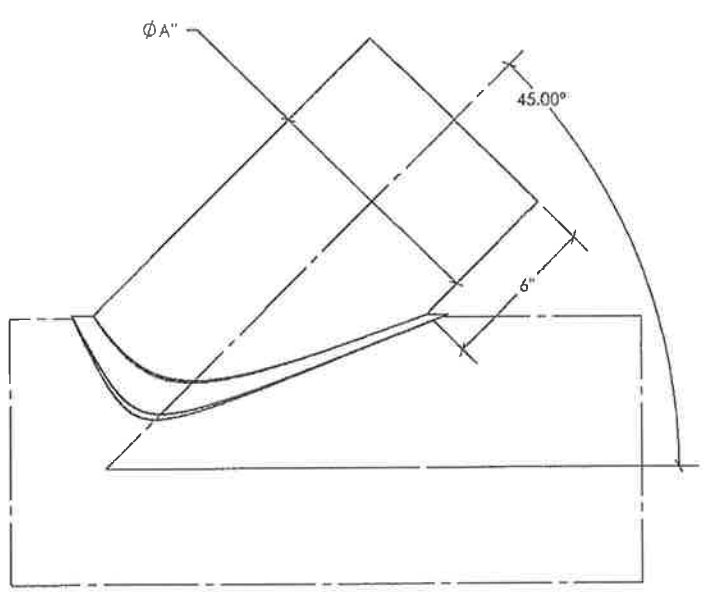
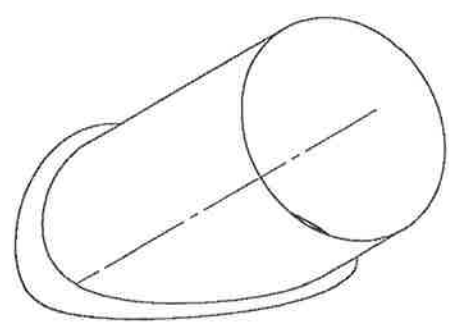

PROPRIETARY AND CONFIDENTIAL  
 THE INFORMATION CONTAINED IN THIS  
 DRAWING IS THE SOLE PROPERTY OF  
 SPUNSTRAND INC. AND ANY  
 REPRODUCTION IN PART OR AS A WHOLE  
 WITHOUT THE WRITTEN PERMISSION OF  
 SPUNSTRAND INC. IS PROHIBITED.

			DIMENSIONS ARE IN INCHES	NAME	DATE	<i>Spunstrand Inc.</i>
			TOLERANCES:	C.JS	2009	
			FRACTIONAL ±	CHECKED		<b>45deg Saddle Tap</b>
			ANGULAR: MACH ± BEND ±	ENG APPR.		
			TWO PLACE DECIMAL ±	MFG APPR.		
			THREE PLACE DECIMAL ±	Q.A.		
			MATERIAL	COMMENTS:		SIZE <b>A</b> DWG. NO. Underslab FRP REV.
	NEXT ASSY	USED ON	FINISH			
	APPLICATION		DO NOT SCALE DRAWING			

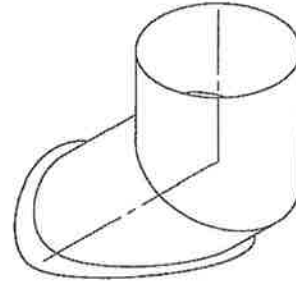
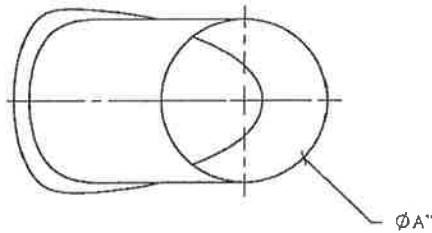

**A onto B**

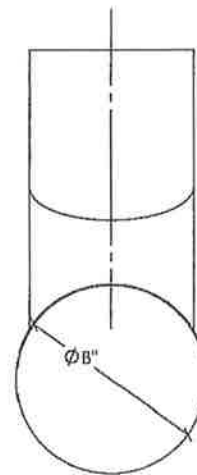
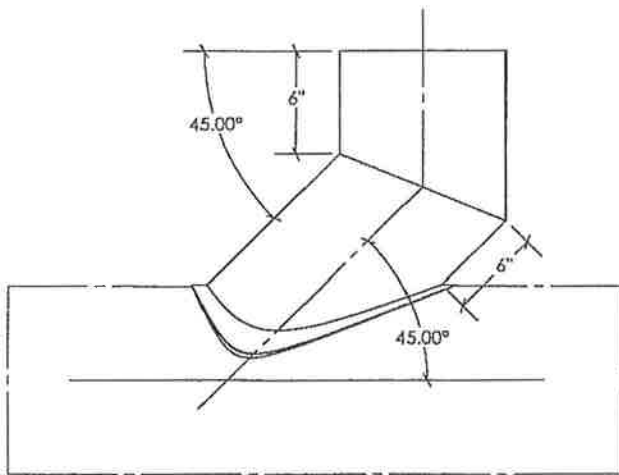

<p><b>PROPRIETARY AND CONFIDENTIAL</b> THE INFORMATION CONTAINED IN THIS DRAWING IS THE SOLE PROPERTY OF &lt;INSERT COMPANY NAME HERE&gt;. ANY REPRODUCTION IN PART OR AS A WHOLE WITHOUT THE WRITTEN PERMISSION OF &lt;INSERT COMPANY NAME HERE&gt; IS PROHIBITED.</p>			<p>DIMENSIONS ARE IN INCHES TOLERANCES: FRACTIONAL ± ANGULAR: MACH ± BEND ± TWO PLACE DECIMAL ± THREE PLACE DECIMAL ±</p>	NAME	DATE	<p><i>Spunstrand Inc.</i></p>	
				DRAWN	CJS		2009
				CHECKED			<p>90deg Lateral Saddle Tap</p>
				ENG APPR.			
				MFG APPR.			
		Q.A.					
				COMMENTS:			
	NEXT ASSY	USED ON	MATERIAL			SIZE <b>A</b>	
			FINISH			DWG. NO. Underslab FRP	
	APPLICATION		DO NOT SCALE DRAWING			REV.	

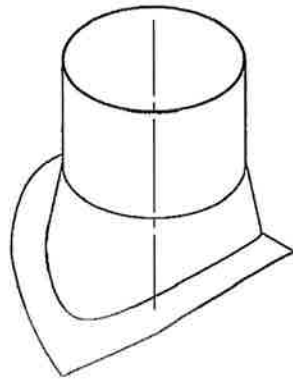

**A onto B**

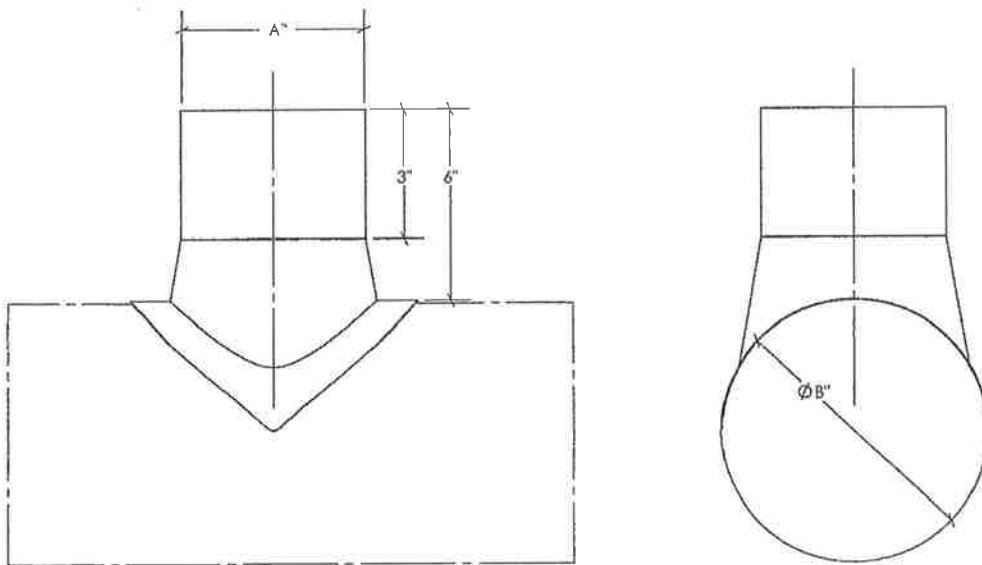

PROPRIETARY AND CONFIDENTIAL  
 THE INFORMATION CONTAINED IN THIS  
 DRAWING IS THE SOLE PROPERTY OF  
 SPUNSTRAND INC. AND ANY  
 REPRODUCTION IN PART OR AS A WHOLE  
 WITHOUT THE WRITTEN PERMISSION OF  
 SPUNSTRAND INC. IS PROHIBITED.

		DIMENSIONS ARE IN INCHES	NAME	DATE	<i>Spunstrand Inc.</i>
		TOLERANCES:	DRAWN	CJS	
		FRACTIONAL ±	CHECKED		Conical Tap
		ANGULAR: MACh ± BEND ±	ENG APPR.		
		TWO PLACE DECIMAL ±	MEG APPR.		
		THREE PLACE DECIMAL ±	Q.A.		
		MATERIAL	COMMENTS:		
NEXT ASSY	USED ON	FINISH			SIZE <b>A</b>
APPLICATION	DO NOT SCALE DRAWING				DWG. NO. Underlab FRP
					REV.



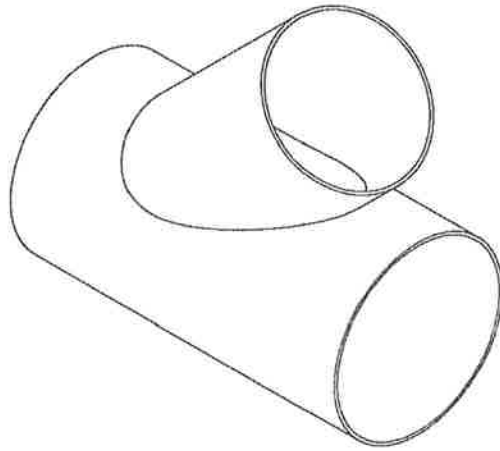

45 DEGREE LATERAL	
"A" DIAMETER	L
4	17 2/3
5	19
6	20 1/2
7	21 8/9
8	23 1/3
9	24 3/4
10	26 1/7
12	29
14	31 7/8
16	34 5/8
18	37 1/2
20	40 1/4
22	43 1/8
24	46
26	48 3/4
28	51 5/8
30	54 1/2
32	57 1/4
34	60
36	63
38	65 3/4
40	68 5/8
42	71 1/4
44	74 1/4
48	79.872
52	85 1/2
54	88 3/8
60	96 7/8
72	113 7/8

A x B

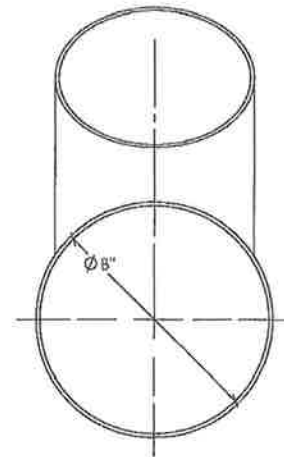
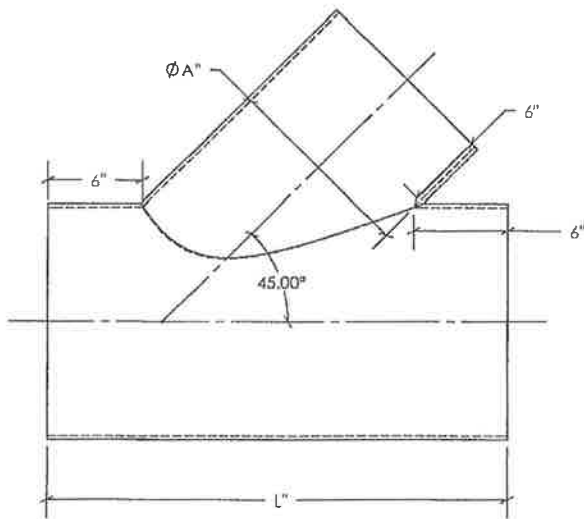

PROPRIETARY AND CONFIDENTIAL THE INFORMATION CONTAINED IN THIS DRAWING IS THE SOLE PROPERTY OF SPUNSTRAND INC. ANY REPRODUCTION IN PART OR AS A WHOLE WITHOUT THE WRITTEN PERMISSION OF SPUNSTRAND INC. IS PROHIBITED.			DIMENSIONS ARE IN INCHES TOLERANCES: FRACTIONAL ± ANGULAR: MACH ± BEND ± TWO PLACE DECIMAL ± THREE PLACE DECIMAL ±	NAME CJS	DATE 2009	<b>Spunstrand Inc.</b>  <b>45deg Lateral</b>		
			MATERIAL	CHECKED ENG APPR. MFG APPR.				
			FINISH	G.A. COMMENTS:				
	NEXT ASSY	USED ON						
	APPLICATION	DO NOT SCALE DRAWING				SIZE <b>A</b> DWG. NO. <b>Underslab FRP</b> REV.		

\*72" and larger diameter ductwork is not included in ICC-ES listing.

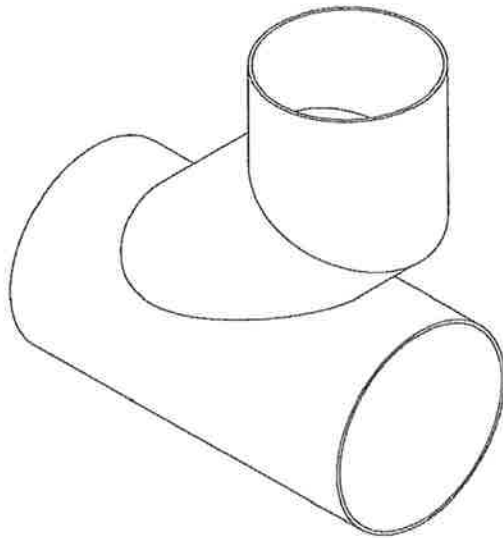

90 DEGREE LATERAL		
INCH DIAMETER	L	H
4	17 2/3	12
5	19	12 1/3
6	20 1/2	12 3/4
7	21 8/9	13 1/7
8	23 1/3	13 4/7
9	24 3/4	14
10	26 1/7	14 2/5
12	29	15 2/9
14	31 7/8	16
16	34 5/8	16 7/8
18	37 1/2	17 5/7
20	40 1/4	18 1/2
22	43 1/8	19 1/3
24	46	20 1/5
26	48 3/4	21
28	51 5/8	21 6/7
30	54 1/2	22 2/3
32	57 1/4	23 1/2
34	60	24 1/3
36	63	25 1/6
38	65 3/4	26
40	68 5/8	26 5/6
42	71 1/4	27 2/3
44	74 1/4	28 1/2
48	79.872	30 1/8
52	85 1/2	31 4/5
54	88 3/8	32 5/8
60	96 7/8	35 1/9
72	113 7/8	40

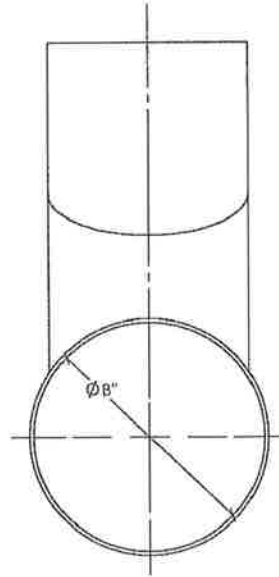
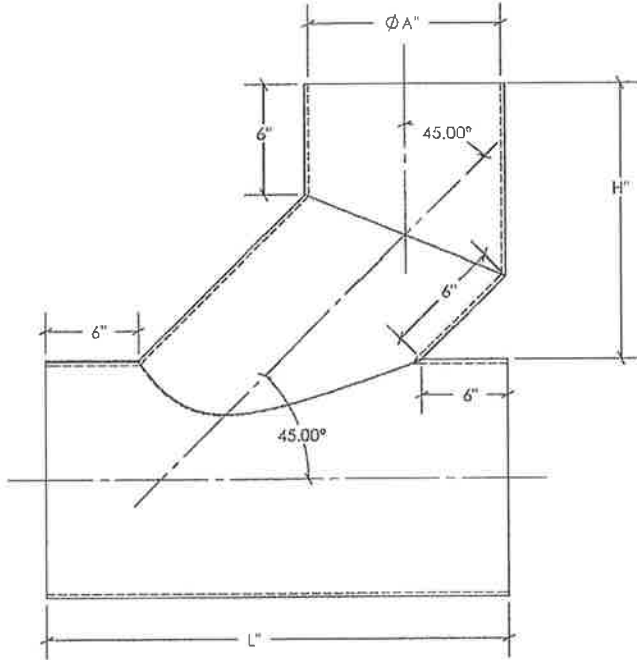

<p><b>PROPRIETARY AND CONFIDENTIAL</b> THE INFORMATION CONTAINED IN THIS DRAWING IS THE SOLE PROPERTY OF &lt;INSERT COMPANY NAME HERE&gt;. ANY REPRODUCTION IN PART OR AS A WHOLE WITHOUT THE WRITTEN PERMISSION OF &lt;INSERT COMPANY NAME HERE&gt; IS PROHIBITED.</p>			<p>DIMENSIONS ARE IN INCHES TOLERANCES: FRACTIONAL: ± ANGULAR: MACH ± BEND ± TWO PLACE DECIMAL ± THREE PLACE DECIMAL ±</p>	NAME	DATE	<p><i>Spunstrand Inc.</i></p> <p><b>90deg Lateral</b></p>	
				DRAWN	CJS		2009
				CHECKED			
				ENG APPR.			
				MFG APPR.			
			MATERIAL	COMMENTS:			
	NEXT ASSY	USED ON	FINISH				
	APPLICATION	DO NOT SCALE DRAWING					

\*72" and larger diameter ductwork is not included in ICC-ES listing.





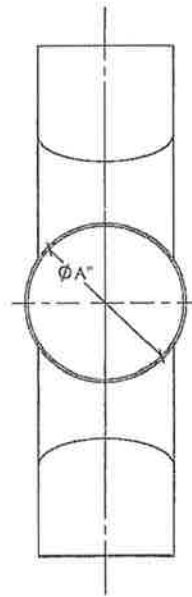
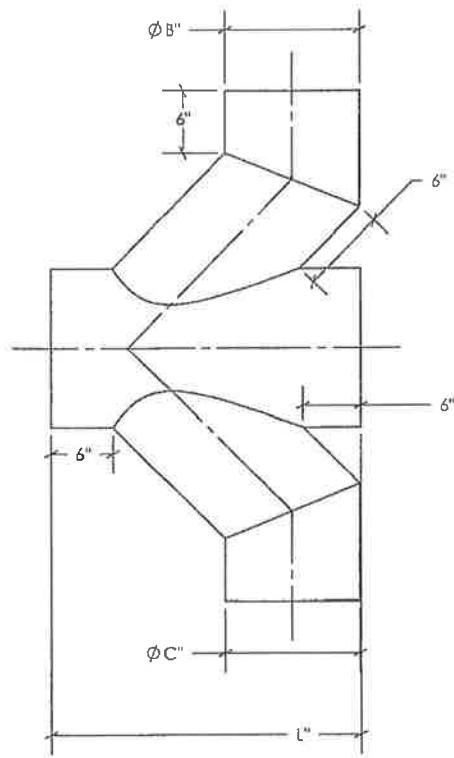
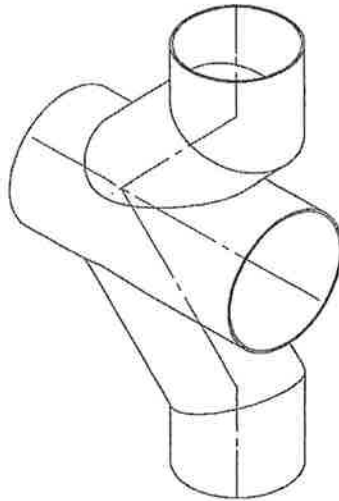

PROPRIETARY AND CONFIDENTIAL  
 THE INFORMATION CONTAINED IN THIS  
 DRAWING IS THE SOLE PROPERTY OF  
 SPUNSTRAND INC. AND ANY  
 REPRODUCTION IN PART OR AS A WHOLE  
 WITHOUT THE WRITTEN PERMISSION OF  
 SPUNSTRAND INC. IS PROHIBITED.

		DIMENSIONS ARE IN INCHES		NAME	DATE	<b>Spunstrand Inc.</b>
		TOLERANCES:		DRAWN	2009	
		FRACTIONAL $\pm$		CHECKED		Double 90deg Lateral
		ANGULAR: MACH $\pm$ BEND $\pm$		ENG APPR.		
		TWO PLACE DECIMAL $\pm$		MFG APPR.		
		THREE PLACE DECIMAL $\pm$		QA.		DWG. NO. Underslab FRP
		MATERIAL		COMMENTS:		
NEXT ASSY	USED ON	FINISH				REV.
APPLICATION		DO NOT SCALE DRAWING				

SIZE **A** DWG. NO. Underslab FRP REV.

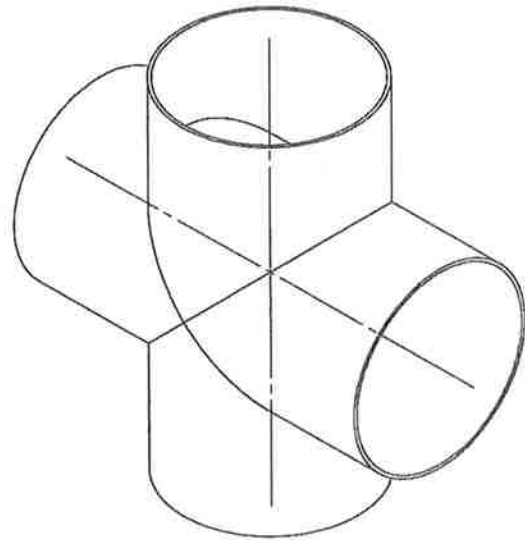
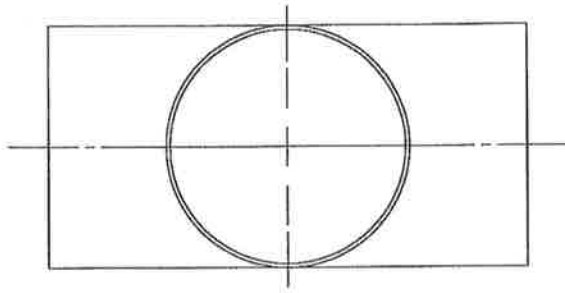

**A x B x C x D**

A & B must be equal diameter (Primary Air Flow)  
 C diameter must be equal to or less than A,B  
 D diameter must be equal to or less than A,B

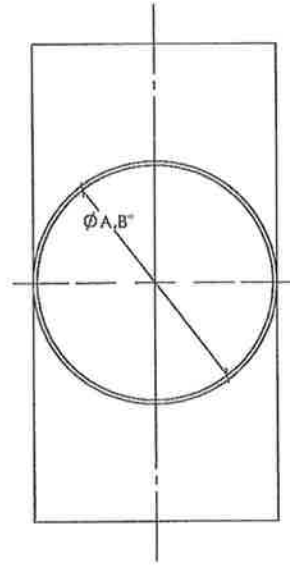
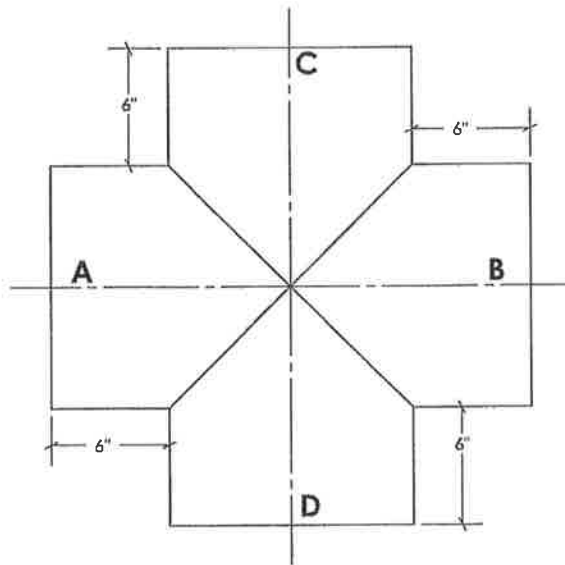

\*Reducing Crosses Available by Request\*

PROPRIETARY AND CONFIDENTIAL THE INFORMATION CONTAINED IN THIS DRAWING IS THE SOLE PROPERTY OF SPUNSTRAND INC. AND ANY REPRODUCTION IN PART OR AS A WHOLE WITHOUT THE WRITTEN PERMISSION OF SPUNSTRAND INC. IS PROHIBITED.			DIMENSIONS ARE IN INCHES TOLERANCES: FRACTIONAL ± ANGULAR: MACH ± BEND ± TWO PLACE DECIMAL ± THREE PLACE DECIMAL ±	NAME	DATE	<i>Spunstrand Inc.</i>  <b>Cross</b>	
				DRAWN	CJS		2009
				CHECKED			
				ENG APPR.			
				MFG APPR.			
		MATERIAL	Q.A.				
		FINISH	COMMENTS:				
	NEXT ASSY	USED ON					
	APPLICATION	DO NOT SCALE DRAWING					
			SIZE	DWG. NO.	REV.		
			A	Underslab FRP			

