

1973 AVION TRAVEL TRAILER

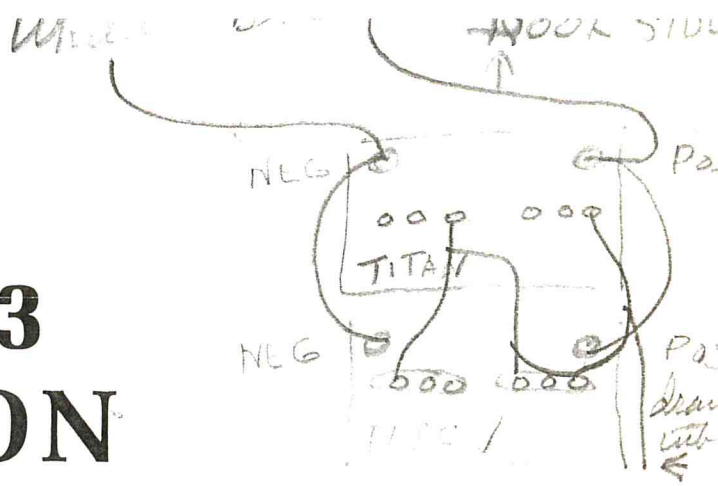

Operation and Service Manual

Keep this book with your Avion at all times

AVION COACH CORPORATION
1300 E. Empire Avenue, Benton Harbor, Michigan 49022

AVION TRAVEL COACH

OPERATION AND SERVICE MANUAL

TABLE OF CONTENTS

Section	Page
I Hook-up Procedure	3
II Towing	4
III Parking & Set-up Procedure	5
IV Protection from Freezing Weather	6
V Operation – Care – Maintenance	7
VI Trouble Shooting	19
VII Warranty Information.	23
VIII Tables, Diagrams and Illustrations	24

SECTION I

GENERAL PROCEDURE FOR "HOOKING-UP" BEFORE A TRIP

The following steps are suggested as a check list before starting on your trip with your Avion Coach.

1. See that all clothing, dishes, golf clubs, fishing gear, etc., are properly stored. It is wise to use square plastic containers in your refrigerator. **DO NOT** leave ice cubes in the freezer compartment unless the refrigerator is operating while traveling. Pack rolled towels in front of the containers in the refrigerator so they will not move about or spill over. Be sure the travel latch is engaged to prevent the refrigerator doors from opening. Unless you plan extended stays far off the beaten path, there is no need to store up on food.

2. Be sure all drawers, cupboards and closet doors are securely latched. The single-piece bathroom door may be latched closed for traveling. If your trailer is equipped with a bi-fold door, it should be hooked open. Latch the adjustable mirror to prevent damage in transit.

3. Radios, TV sets, books, folding chairs, etc., should not be placed on top of beds while traveling. The vibration of the mattress and springs has a tendency to move everything forward and, if the brakes are applied quickly, they may be thrown to the floor. Heavy gear should be located near the floor and forward of the center of the trailer. **Do not overload your coach.** Refer to Section VIII, Table A for maximum cargo weight, gross vehicle weight and recommended hitch weight.

4. If your utilities are hooked up, disconnect the 120 volt Power Cord at the receptacle and store in the cord storage compartment. Close the range top pilot valve, if pilot has been used. Close the oven shut-off valve. See instructions for Range and Oven in Section IV.

5. Flush the sewage holding tank, refill with 2" of water and add a commercial holding tank chemical, if desired. Disconnect the sewer and water hoses, drain and store. The sewer hose may be kept in the rear bumper. **Be sure to lock the holding tank valves into closed position, and turn off the water pump switch.**

6. Close all windows and ventilators, lower the TV antenna and lock the entrance door. Be sure the front awning is closed and latched on both sides.

7. Remove the stabilizing jacks or blocks from under the coach and fold the step into the "stored" position.

8. A 2³/₁₆" hitch ball should be mounted on your car, so that the top of the ball is 19" from the ground. At this height, and with an equalizing hitch properly adjusted, your Avion coach will ride level. Although the Avion will tow properly even if the coach is not perfectly level, we recommend that trailer and car ride as level as possible.

To hook the coach to the towing vehicle, raise the front of the coach with the post jack and have your partner back the car into place.

After the ball has been positioned under the hitch socket, check to be sure that the locking lever has been raised and pulled to the rear, then lower the front end of the coach onto the ball. Rock the car back and forth enough to be sure that the socket and ball are fully engaged, and put the ball lock in place. The lock should be secured by placing a safety pin or small lock through the hole just to the rear of the latch.

Jack up the front of the coach again (the car will come up with it) and put on the balance of the hitch, adjusting for level in both units. It is advisable to use an equalizer type hitch with sway control. Make all adjustments according to the manufacturers instructions.

Lower the coach onto the hitch, remove the dolly wheel, or any blocks that may have been used under the post, and crank the jack post to the highest possible position. Hook up the electric connections from the car to the coach, connect the safety chains and anchor the break-away switch cable to the auto.

9. Check the brakes and lights.

10. Re-check all previous steps and be sure to leave your parking area clean. It is a good practice to pull your coach a short distance from the parking spot and inspect the area before departing.

SECTION III

PARKING AND SET-UP PROCEDURE

1. When positioning the coach, try to select a spot as level as possible. Do not use jacks to level the coach. It should be leveled by driving up on a board, or by using a shovel to level the area under the wheels before positioning. Jacks can then be used to stabilize the coach.

CAUTION: When locating jacks or blocks, **DO NOT** place them under the aluminum underbelly or skin. Stabilizing jacks for Avion coaches should be placed under the frame at the front and rear of the coach. Extend the jacks only enough to support the frame.

2. Make water, sewage, and electric hook-ups if your stay will be long enough to require them.

3. Light pilot lights, raise front awning and lock in place.

4. If your coach is equipped with a TV antenna be sure to raise it before opening the rear ceiling vent.

SECTION V

OPERATION – CARE – MAINTENANCE

Item	Description	Page
1.	Care and Cleaning	8
2.	Window Screens and Storms	9
3.	Door Lock	9
4.	Electrical Systems	9, 10
5.	Water System	10, 11
6.	Gas System	11
7.	Water Heater	12, 13
8.	Gas Furnace	13
9.	Water Closet	13, 14
10.	Waste Holding Tank	14
11.	Gas – Electric Refrigerator	14, 15
12.	Range and Oven	15
13.	Range Hood	15
14.	Running Gear	15, 16
15.	Converter	16
16.	Break-Away Switch	17
17.	Instrument Signal Center	17
18.	Air Conditioner	17
19.	TV Antenna	18
20.	Water Purifier	18
21.	Sound Systems	18

2. WINDOW SCREENS and STORMS

Removal of the window screen is accomplished by pushing upward on the screen frame until it clears the bottom channel. It can then be pulled out from the bottom and removed.

3. DOOR LOCK

The entrance door is equipped with a "Dead-bolt" lock. Turn the key to the right (clockwise) to lock the door, and to the left (counter-clockwise) to unlock it.

The door can only be locked when the bolt is fully engaged. When locked, the bolt cannot withdraw or vibrate back and allow the door to come open. Always lock the door before towing your Avion. Check the lock by attempting to open the door with the outside handle.

The door can be locked from the inside by lifting the lever under the handle. Do not attempt to lock the door while open and then close it.

4. ELECTRICAL SYSTEMS

Each Avion coach is provided with three separate electrical circuits: (A) 12-volt exterior light and brakes; (B) 12-volt interior lighting system; (C) 120-volt interior system.

(A) **Exterior Lights** – The cluster lights and clearance lights are I.C.C. regulation approved. Check these lights periodically to be sure that the bulbs are burning. Replacement bulbs are G.E. type 1895 or equivalent. The tail lights and turn lights are in single lamps at the rear of the coach. They use double filament bulbs, G.E. type 1157 or equivalent.

Power for the lights and brakes is supplied from the automobile battery, through the 7-wire connector. The coach wires appear in a heavy cable at the trailer hitch.

WIRING CODE FOR AVION COACHES

#1 – White	connects to:	Brake – Ground
#2 – Blue		Brake – Hot
#3 – Green		Clearance Lights
#4 – Black		Battery Charging by Tow Vehicle
#5 – Red		Left Turn Light
#6 – Yellow (Brown)		Right Turn Light
#7 – Black-Center Post		Backup Lights

The black wire from the No. 4 terminal is connected to the positive terminal of the two self-contained trailer batteries. This wiring is correct for all tow vehicles with standard "negative ground" systems.

Brakes – Your coach is equipped with 12-volt electric brakes. The 25 ft. and 28 ft. tandem axle models are equipped with 10" brakes. The 31 ft. tandem axle model is equipped with 12" brakes.

These brakes have been adjusted at the factory for smooth, positive braking. If brake adjustment becomes necessary it should be done by your dealer's service department or by a competent automotive mechanic. The method of adjustment is the same as most automotive brakes.

INTERIOR LIGHTING

(B) **Interior Lights** – The lights, fans and water pump are operated on 12-volts direct current. This energy may be provided by the standard equipment batteries which are located at the front of the trailer, or by the converter.

Two 12-volt batteries are provided to give a greater amount of reserve energy for self-contained operation. These batteries are connected in parallel. Should one battery fail to function, the other battery will continue to provide power, to the limit of its capacity. If, for any reason, one battery is removed from the circuit, be sure that it is correctly re-connected, as illustrated on page 10.

The batteries should be checked periodically to be sure that they are at the proper charge level. Use a hydrometer to test the individual battery cells. A fully charged battery will have a specific gravity reading of 1.260 to 1.280 at 80 degrees fahrenheit.

When checking a battery, be sure that the level of the electrolyte (water) is adequate to cover the tops of the separators. Permanent damage may occur from charging and/or from traveling with plates not fully covered. When the electrolyte is low, add filtered or distilled water to obtain the proper level. Keep the battery terminals clean by wiping with a cloth wetted in baking soda or ammonia and water. Inspect wires and battery terminals for corrosion or poor connections.

To prevent damage to the batteries, never allow them to become fully discharged. The specific gravity should not be allowed to drop below 1.150. Be sure that the 120-volt power cord is fully plugged into the outlet whenever AC service is available. Use of 120-volt service will not only save battery energy, but it will also provide automatic charging to keep your batteries in top condition.

All trailer models are equipped with two General Battery TITAN 85 A.H. Recreational Vehicle Batteries. These batteries carry a 24 month service adjustment policy and a 90 day warranty against defects in workmanship or material.

For information as to the nearest Titan Battery dealer or distributor, see the Yellow Pages or call collect GENERAL BATTERY CORP., AC 215-929-0771.

The Titan Battery Stock No. is RVS-24-6. A copy of the battery Owner's Guide is included in each warranty package.

The converter, or charger, provides 12-volt direct current whenever the power cord is plugged into a standard 110-120-volt 60 cycle AC source. It also provides the energy to charge the batteries. As a battery charger, the unit

Water System (cont'd)

The fill spout is located on the outside of the coach. The tank may be filled by pulling out the spout cover and inserting the end of a water hose. A bi-pass line is also provided to permit filling the tank while connected to a city water supply. The location of the valve is shown in ILLUSTRATIONS B & C, manual section VIII.

To assure complete sanitation of your potable water system, it is recommended that the following procedures be followed on a new system, one that has not been used for a period of time, or one that may have become contaminated:

1. Prepare a chlorine solution using one gallon of water and ¼ cup of Chlorox or Purex household bleach (5% sodium hypochlorite solution). Pour one gallon of solution into tank for each 15 gallons of tank capacity.
2. Complete filling of tank with fresh water. Open each faucet and drain cock until all air has been released from the pipes and entire system is filled.
3. Allow to stand for three hours.
4. Drain and flush with potable fresh water.
5. To remove any excessive chlorine taste or odor which might remain, prepare a solution of one quart vinegar to five gallons water and allow this solution to agitate in tank for several days by vehicle motion.
6. Drain tank and again flush with potable water.

The water tank may be drained by opening any faucet with the pump turned on or by opening the drain valve at the end of the tank.

The coach is equipped with a Peters & Russell water pump to supply water pressure whenever a faucet is turned on. A switch is provided to turn the pump off while the coach is unattended, or when connected to a city water supply. **DO NOT TRAVEL WITH THE WATER PUMP SWITCH IN THE "ON" POSITION.** The surge of water, which can occur during starting and stopping, may cause the pump to turn on. Since no water can run and allow the pump to cycle, it will continue to run and not shut off.

The pump is mounted on the floor near the water tank access opening. It has a built-in check valve to prevent water from backing up into the storage tank when the system is connected to a city water source.

The model 6950-J pump is warranted by the manufacturer for a period of **one year**. Warranty service and parts may be obtained from: **Peters and Russell, Incorporated, 529 West Liberty Street, Springfield, Ohio 45501.** Their telephone number is AC 513 323-3777.

A filter is located in the water line between the tank and the pump. Inspect this filter periodically to be sure that an accumulation of foreign matter does not impair the water flow. The filter may be cleaned by removing it and

rinsing or back-flushing, or by disassembling the two halves and removing the screen to clean it.

The trailer plumbing fixtures are of the single control type. Lift up on the valve knob to turn on and push down to turn off. Turn to the right or left to select water temperature.

The bathtub is constructed of molded fiberglass. Cleaning should be done with a liquid detergent, then rinse. Do not use abrasive cleaners as they will dull the surface.

The tub has a Delta model 636 valve and spout. Push in on the valve divert button to use the shower head. When the valve is closed the button will return to the normal position so that the tub may be filled from the spout.

The built-in push button control in the shower head is designed for volume control (water saver) and is not intended as a shut-off valve. A slight trickle in the closed position is normal.

The bath lavatory is equipped with a Delta model 522 faucet. The galley sink has a Delta model 111 faucet. All Delta fixtures are warranted by **DELTA FAUCET COMPANY, Greensburg, Indiana 47240.**

6. GAS SYSTEM

The coach gas system consists of two gas tanks or bottles, a regulator, gas distribution piping, and the various appliances which operate on gas.

This system is designed for use of liquefied petroleum (LP) gas only. Do not connect natural gas to this system. Before turning on gas, make certain all gas connections have been made tight, all appliance valves are turned off, and any unconnected outlets are capped.

After turning on gas, test piping and appliances for leakage with soapy water, and light all pilots.

The two gas bottles are located at the front of the coach. Each is equipped with a valve to control the flow of gas. A regulator is used at the tanks to reduce and control the pressure from the tanks to the appliances. The regulator is preset at the factory to maintain a pressure of 11" water column, or approximately 6½ ounces per square inch. All appliances are adjusted to operate at this pressure.

When filling bottles, do not leave end of gas line (pig tail) open, even for a few minutes. Bugs are attracted, die inside tubing and plug the line. Tape tube end shut while filling bottles.

Automatic Regulators

Automatic regulator provides uninterrupted service to your gas system. Both bottle valves must be open to permit automatic change-over. An indicator on the regulator will show red when the regulator automatically begins to draw from the reserve cylinder. The arrow on the flip-over lever will point to the empty service cylinder.

Water Heater (cont'd)

depends on the gas and air mixture at the main burner, this is obtained by sliding the air shutter. A yellow smoking flame indicates a lack of air and noisy hard flame indicates an excess of air. A good method of adjusting the air shutter is to slide the shutter closed enough for yellow tipping to occur on the main burner (not pilot) then slowly open air shutter until yellow tipping is gone, then tighten screw.

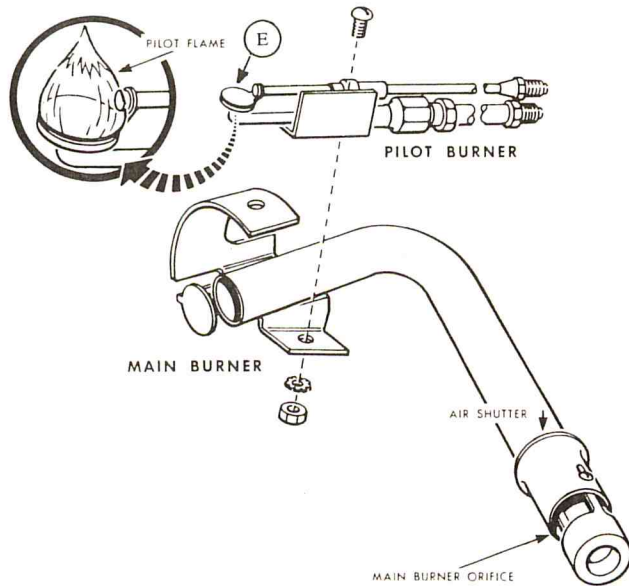

The drain valve is located in the front of the heater. The unit should be drained as required per Section III in this manual.

IT IS NORMAL FOR WATER TO DRIP FROM THE WATER HEATER RELIEF VALVE WHILE WATER IS BEING HEATED. THE VALVE IS RELIEVING THE PRESSURE BUILDUP CAUSED BY THE EXPANSION OF HEATED WATER.

The Bowen Model RGC6A water heater is warranted by the manufacturer for a period of 12 months, according to the terms of their warranty statement. Consult the warranty sheet for complete details.

Warranty service and parts may be obtained from: **ATWOOD VACUUM MACHINE COMPANY, 1400 Eddy Avenue, Rockford, Illinois 61101.** The telephone number is: AC 815 877-5771. Your coach warranty package includes detailed information on the Bowen warranty and a list of Bowen Service Stations where their work may be performed.

8. GAS FURNACE

All coach models are equipped with Suburban Dyna Trail forced air furnaces. The hot air is carried by ducting to several locations in each trailer. The 25 foot model is equipped with a 22,000 BTU furnace. The 28 ft. and

31 ft. models use a 30,000 BTU furnace.

The furnace is installed on the right side of the trailer. Combustion air is taken in and discharged through the trailer wall. Do not restrict the openings.

The furnace controls are located behind the vented cold air return door. To light the furnace, open first the cabinet door and then the metal door on the furnace. Lighting instructions are located on the back side of the metal door, and also explained in detail in the Suburban manual provided in each Owner's Envelope.

To turn the furnace off in warm weather, close the gas line valve and turn the thermostat to the "off" position.

The return air intake is through the perforated access door panel. Do not block the flow of air through this panel. The hot air registers should also be kept clear at all times.

Both furnaces, Model NT-30 and the NT-22 are warranted for a period of **one year** according to the terms noted on the warranty form. Warranty service and parts may be obtained from: **SUBURBAN MANUFACTURING COMPANY, Box 399, Dayton, Tennessee 37321.**

The telephone number is: AC 615 775-2131. Collect calls regarding warranty problems will be accepted.

9. WATER CLOSET (TOILET)

Your Avion is equipped with a Thetford Aqua Magic pedal-operated water closet. Operating instructions are as follows:

1. Directions for Automatic Flush and Refill:
 - A. Depress both foot pedals, thus opening the slide valve and dropping the waste into the holding tank. The small pedal turns the water on.
 - B. Keep both foot pedals depressed from one to three seconds until water begins to swirl in the bowl, rinsing it. This short time lag fills the rim storage (for bowl refill) and allows the bowl to drain.
 - C. Release both foot pedals. This closes the slide valve and stops the usage of fresh water. The rim storage now drains and refills the bowl.
2. Directions for Flushing with the Slide Valve Open a Minimum Amount of Time:
 - A. Depress the small pedal on the right and hold it down until the water begins to swirl in the bowl.
 - B. Release the small pedal.
 - C. Step on the large pedal, thus opening the slide valve and dropping the waste into the holding tank. The water will immediately swirl in the bowl, rinsing it. Note that the large foot pedal carries the small pedal down with it, when it is depressed. The time lag in the flush is eliminated,

continued on next page

Gas-Electric Refrigerator (cont'd)

Periodic maintenance procedures are described in the Instruction Booklet which is furnished with each refrigerator.

Components in Dometic refrigerators are warranted for various periods from 3 months to 5 years. Refer to the warranty policy, included with each refrigerator, for specific information. Warranty service and parts may be obtained from **DOMETIC SALES CORPORATION, P.O. Box 490, 2900 W. Mishawaka Road, Elkhart, Indiana 46514.** The telephone number is AC 219 523-4510.

On the West Coast contact **WARD & SON, INC., P.O. Box 3505, 15343 Proctor Avenue, City of Industry, California 91744.**

12. RANGE and OVEN

The Magic Chef Range installed in your coach is equipped and adjusted for use with L.P. gas. To light the range burner hold a lighted match to the edge of the burner orifice ring and turn the burner control knob to the "ON" position. The primary cone of the flame should be approximately 1/2" long. For adjustment instructions refer to the Installation and Service Manual which is provided with each range.

The range top pilot valve has been turned off at the factory to prevent accidental gas-build-up in the coach. Under normal conditions it is best to use a match to light the burners. When stopping for any length of time the top pilot may be turned on for added convenience. **BE SURE THIS VALVE IS TURNED OFF BEFORE LEAVING THE CAMP SITE.** Turn the valve clockwise to close it. Turn only enough to cause the pilot flame to go out. Excessive tightening of the valve screw will damage the seat.

How the Oven System Operates

When the oven thermostat is turned on, gas will flow to the heater pilot, which will be ignited by the constant pilot flame. The flame from the heater pilot will heat the responsive element of the safety valve and open the valve seat allowing gas to flow to the oven burner. The burner then is ignited by the standby pilot flame.

When the oven reaches the set temperature, the thermostat will shut the gas off to the heater pilot, the capillary will cool closing the valve seat and shut off the gas to the oven burner. When the temperature drops, the thermostat will again allow gas to flow to the heater pilot, activating the safety valve and allow the oven burner to be relit. This action will continue throughout the cooking period.

Oven Lighting Procedure

A. The shut off valve for the Safety Control gas supply line is located on the oven control. Depress the oven

control knob and turn counterclockwise to the "OFF" position. This will allow gas to flow to the constant pilot.

- B. Light the Constant Pilot. This is the small tube located at the back of the oven, just to the right of the main oven burner. Use a match or straw to introduce a flame to the end of the pilot tube. See illustration at right.

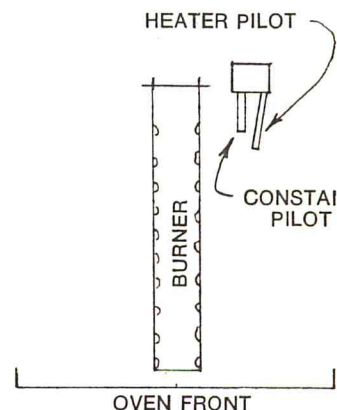

- C. Turn the oven Control Knob to 300°F. temperature setting on the dial. This will allow gas to flow to the heater Pilot Tube, to be ignited by the Constant Pilot.

The Range Oven is equipped with a safety ignition system that requires a minimum of 30 seconds to operate after turning the oven knob on.

After the oven burner has lighted, set the control knob to the desired temperature. Turn the oven control knob to "OFF" when the oven is not in use. This will allow the constant pilot flame to burn while the coach is parked.

To turn off the constant pilot, depress the control knob and turn clockwise to the "PILOT OFF" position. **ALWAYS PLACE THE CONTROL KNOB IN THE "PILOT OFF" POSITION WHEN TOWING THE COACH.**

The Magic Chef model 728DR Range is warranted to the original purchaser for a period of **90 days** according to the terms of the warranty policy. Warranty service and parts may be obtained from: **MAGIC CHEF, INCORPORATED, 3333 Hammond Avenue, Elkhart, Indiana 46515.** The telephone number is: AC 219 264-9578.

On the West Coast you may contact **MAGIC CHEF, INCORPORATED, PAN PACIFIC DIVISION, 245 North Vineland, City of Industry, California 91744.**

13. RANGE HOOD

The Range Hood is equipped with a filter, fan and side-wall duct to filter and discharge fumes and cooking odors from the coach. The filter may be removed for cleaning by sliding it out. A 12-volt lamp provides illumination of the cooking area. This lamp uses a 25 watt, 12-volt standard base bulb.

14. RUNNING GEAR

Suspension

Avion Coaches are equipped with Smooth-Glide suspen-

continued on next page

Converter (cont'd)

built-in circuit breakers. If a short or overload is occurring, a 7 to 10 second clicking sound will be heard as the automatic reset breaker clicks off and on. **DO NOT PERMIT THE BREAKER TO CONTINUE TO CYCLE.** Prolonged cycling will cause heat build-up in the 12-volt circuits, resulting in damage to the coach wiring.

The Model PD-708 converter is equipped with a removable electronic circuit board. Should the 12-volt circuitry in the converter fail to operate properly, the board can be replaced without the necessity of exchanging the complete converter. The circuit board may be removed by squeezing together the plastic clips at each end and pulling out the board. These parts are located behind the converter end panel. Do not attempt to remove them until the converter is disconnected from the wall outlet.

The PD-708 converter is warranted by the manufacturer for a period of one year, according to the terms and conditions of the warranty certificate. Warranty service or replacement circuit boards may be obtained from **PROGRESSIVE DYNAMICS, INCORPORATED, P.O. Box 168, Marshall, Michigan 49068.** Their telephone number is: AC 616 781-4241.

16. BREAK-AWAY SWITCH

The Break-Away Switch is provided as a safety feature. It is equipped with a steel cable which must be anchored to the towing vehicle at the time of hook-up. If the coach should be accidentally disconnected from the towing vehicle, the cable will pull the switch pin causing the coach brakes to be applied automatically.

The removal of the pin from the switch closes the brake circuit, applying electrical energy from the coach battery to the brake magnets. Replacing the switch pin opens the circuit, releases the brakes and allows the coach to roll free again.

17. INSTRUMENT SIGNAL CENTER

The signal center is located in the overhead cabinet at the front of the trailer. THE PANEL OFFERS the following features:

A series of five horizontally spaced lamps are arranged on the panel to indicate the level of the three tanks in the system. These lamps illuminate five levels of the tank: "0", "1/4", "1/2", "3/4" and "F" for full. The highest illuminated level is the correct reading.

1. **Water Level Indicator.** The extreme left switch will indicate the water level in the potable water storage tank.
2. **Waste Holding Tank (Tank 1).** Depress the second switch from the left end to determine the liquid level in the tank retaining waste from the stool.
3. **Rinse Holding Tank (Tank 2).** Depress the center switch to determine the liquid level in the tank holding drain water from the tub and sinks.

4. **Battery Condition.** Depress the "Battery Condition" switch to observe the indicator lamps marked "Low", "Fair" and "Good". Disconnect the power cord or turn off the main breaker before checking the batteries if the trailer is plugged into a 115 V. power supply. The reading should be taken with lights and fans turned off.
5. **Water Pump Switch.** The switch on the extreme right is the water pump switch. It should be turned on when using water from the storage tank. Be sure the switch is turned off when traveling, or when leaving the coach unattended. A panel light will illuminate the word "pump" whenever the pump switch is in the "on" position.
6. **Power on.** A panel lamp is provided to indicate "Power on". This lamp will be lit whenever the trailer power cord is plugged into a 115 V receptacle. It is provided to prevent discharge of the batteries which might be caused by accidental disconnection of the power cord. This circuit is protected by a 2 ampere fuse which is located in the power converter. The panel legend plate is retained with two thumb screws so that it may be removed to facilitate the replacement of burned-out bulbs. All lamps use no. 53, 12 volt bulbs.

The signal center is warranted for a period of one year. For warranty work, service parts or information contact: **WEMAC, 3433 Harvard, Santa Ana, California 92704.** Defective panels returned to this address within the warranty period will be repaired at no charge.

18. AIR CONDITIONER (Coleman — Opt.)

The Coleman Polar Pal air conditioner is designed to provide comfort in a wide variety of applications. The unit is turned "ON" or "OFF" with the selector switch. Use "LO FAN" or "HI FAN" setting on selector switch for air circulation during mild weather.

Use "HI-COOL" and maximum thermostat setting for hot, humid weather. Use "HI-COOL" and medium thermostat setting for hot, dry weather. Use "LO-COOL" and maximum thermostat setting for mild, humid weather.

Clean the filter regularly. Wash in mild suds water, rinse thoroughly and dry. Occasionally, check the outdoor coil for leaves, lint, paper, etc. This coil grill must remain free and clear for efficient cooling.

Check the air inlet above the filter occasionally. Remove lint or other foreign material with a brush or vacuum.

NOTE: After air conditioner has been shut off, it will not start again for approximately 5 minutes.

Both the Coleman MACH I (10,000 BTU) and the MACH II (12,000 BTU) air conditioners are warranted for a period of one year. Warranty terms and conditions are described on the Certificate supplied with each unit. Warranty service and parts may be obtained from any

SECTION VI

TROUBLE SHOOTING

AIR CONDITIONER

Trouble: Will not run.

Cause and Remedy:

- a. Power Cord not making good connection at parking area service receptacle. Make sure that plug is fully inserted and the weight of the cord does not pull it from the receptacle.
 - b. Circuit breaker is in "Off" position. Reset.
- Trouble: Does not cool properly.**
- Cause and Remedy:
- a. Filter dirty. Clean and replace.
 - b. Low voltage from source and compressor will not operate. Move to spot where voltage is proper.

BATTERY

Trouble: Batteries do not charge while coach is being towed.

Cause and Remedy:

- a. Blown fuse. Replace with correct size.
- b. Poor connection at hitch. Clean 7-wire connector contacts and reconnect.
- c. Charge wire not "Hot". Rewire car so charge wire is "Hot".

Trouble: Batteries do not charge when 25 ft. Power Cord is connected to 120-volt source.

Cause and Remedy:

- a. Power cord is not making good contact at receptacle. Check connection.
- b. Blown fuse. Replace with correct size.
- c. Low line voltage at 120-volt source. Use outlet nearer to power source.
- d. Circuit Breaker is in "Off" position. Check and reset.

Trouble: Both batteries dead, power cord not plugged in.

Cause and Remedy:

- a. Check for light or fan left turned on while trailer was unattended for an extended period. Turn off the fixture or appliance which was accidentally left on. If unable to find the cause of discharge, remove the battery fuses until a service man can correct the trouble.

Recharge dead batteries as soon as possible. Allowing them to remain in a state of discharge for any length of time will cause permanent damage.

When plugging in the trailer power cord to charge dead batteries, be sure to do so at a time when the batteries can be observed during the charging cycle. Inspect the battery cases periodically for signs of heating or boiling of the electrolyte. **IF HEATING OCCURS, DISCONTINUE CHARGING AT ONCE TO AVOID CAUSING PERMANENT DAMAGE.**

Contact your local auto service station, or your nearest Avion Dealer for assistance in recharging batteries that have a tendency to heat up. This condition may be a sign of temporary battery damage.

Trouble: One battery dead.

Cause and Remedy:

- a. Poor battery connections. Clean terminals and tighten connections.
- b. Defective battery. Replace. See warranty procedure on page 10.

BRAKES

Trouble: No brakes.

Cause and Remedy:

- a. Broken wire in brake circuit. Use continuity tester or voltmeter to trace brake wires and splice.
- b. Poor connection between car and coach. Clean terminals and check for broken wire at the 7-wire connector.

Trouble: Unequal brakes.

Cause and Remedy:

- a. Broken wire at brake drum. Locate and splice.
- b. Improper shoe adjustment. See a service shop.

Trouble: Poor brakes, brakes inadequate.

Cause and Remedy:

- a. Inadequate voltage to brake magnets. Check brake control for good connection to battery.
- b. Brake shoes need adjusting. See service shop.

Trouble: Brakes lock and will not release.

Cause and Remedy:

- a. Short in break-away switch. Replace.
- b. Break-away switch pin has been pulled. Replace pin.
- c. Incorrect brake adjustment. Too much shoe clearance. Have brakes re-adjusted.

Trouble Shooting (cont'd)



If you have a jack, you can “chain up” the axle by placing the jack under the axle at the end which has the flat and raising it as high as it will go. Take the chain, which is supplied and which is exactly like the safety chains on the front of the coach, and insert one end into the slotted angle iron welded to the frame of the trailer. Place the chain under the slot of the other angle iron as tightly as possible. Be sure to hook the chain as illustrated below.

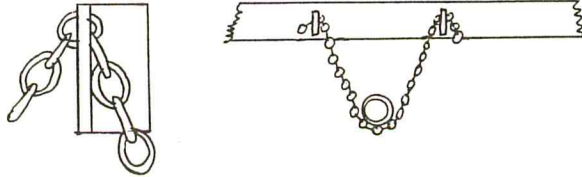

Remove the jack. The tire should clear the road slightly. If it is convenient you can remove the tire. If not, you may leave it on the axle. In any case you should drive slowly while the axle is “chained up” and refrain from driving any further than necessary.

For ease in removing a wheel from a tandem axle coach, first jack up the good wheel on the same side as the flat. Place a 4” or 5” block under the good tire and lower the wheel onto the block. Now place the scissor jack under the axle with the flat tire and lift it off the ground just enough to allow removal of the wheel, and mounting of the spare.

When re-tightening the lug bolts, torque them first to about 25 FP skipping every other one so that the wheel is pulled into the drum uniformly. Continue around the wheel in the same order, increasing the torque until all bolts are torqued to 90-100 Foot Pounds.

WARNING: Be sure to place blocks against both wheels on the side of the trailer opposite the flat tire to prevent the coach from rolling while the wheel is being changed.

To change a tire when no jack is available, the following steps will permit lifting the flat tire off the ground:

1. Drive the flat tire up on a wedge or stack of boards that is approximately 5” high.
2. Chain up the axle as described above. Adjust the chain as tight as possible.

3. Pull the wheel with the flat tire off the blocks and pull the good wheel up on the same blocks. This should raise the flat tire off the ground to permit changing.

This procedure is suggested as an emergency measure only.

WARNING: Never get under the coach when it is blocked up.

Caution: Do not discard a defective tire, it will be necessary to present it if an adjustment is sought.

WATER PURIFIER

Trouble: No water flow, or very slow flow rate.

Cause and Remedy:

- a. Restriction in water line. Make sure all valves are open and there are no kinks in copper tube lines.
- b. Low water pressure. Use low pressure cartridge if water is pre-chlorinated.
- c. Plugged cartridge. Install new one.

Trouble: Very short cartridge life.

Cause and Remedy:

- a. Large amount of suspended matter in raw water. Install new cartridge.

Trouble: Off-taste, color, or odor in purified water.

Cause and Remedy:

- a. Install new cartridge.
- b. Reduce flow rate through purifier.

Trouble: Suspended matter in purified water.

Cause and Remedy:

- a. Purifier is leaking internally. Install new rubber kit.

WATER HEATER

Trouble: Will not heat on “Electric”.

Cause and Remedy:

- a. Power Cord not making good connection at parking area service receptacle. Make sure that plug is fully inserted and the weight of the cord does not pull it from the receptacle.
- b. Circuit breaker is in “Off” position. Reset.
- c. Switch on heater jacket is turned off. Turn on.
- d. Water heater cord is not plugged into wall outlet. Plug in.

continued on next page

SECTION VII

WARRANTY INFORMATION

Service, repairs and parts for your Avion Coach may be obtained through any of the many Avion dealers across the country, or from:

Avion Service Corporation
1576 E. Empire Avenue
Benton Harbor, Michigan 49022
Telephone — 616-927-2271

The Avion Service Corporation is able to perform virtually any of the service work in accordance with our suppliers' warranty.

Avion Service Corporation operates on an appointment basis only. For a service or repair appointment call or write in advance.

* * * * *

Warranty service and parts for many components that are manufactured by Avion suppliers may be obtained direct.

Addresses of these suppliers are found in your AVION WARRANTY, OPERATION and SERVICE KIT envelope.

TABLE B
PROTECTION FROM FREEZING WEATHER
TWIN BED MODELS

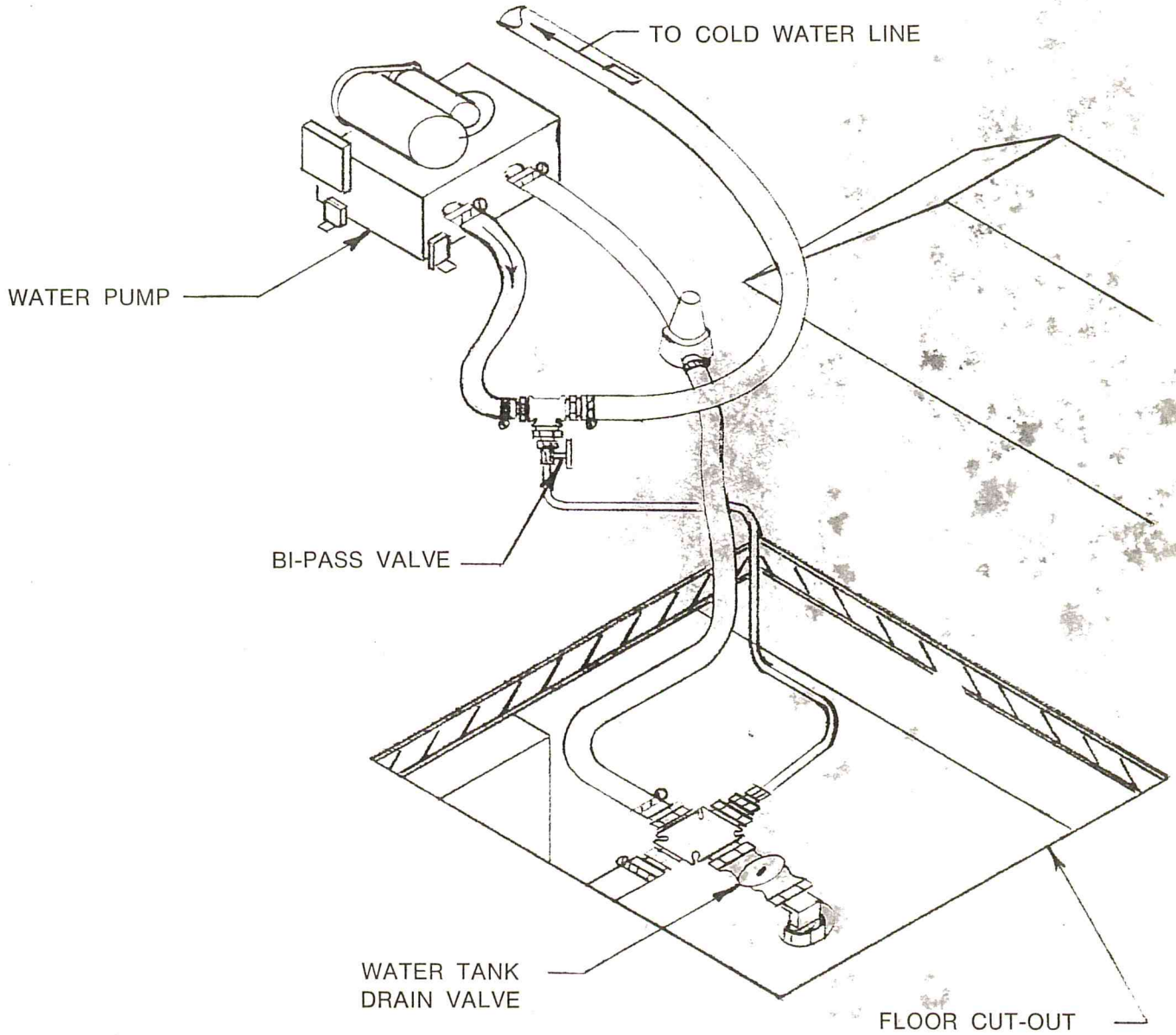
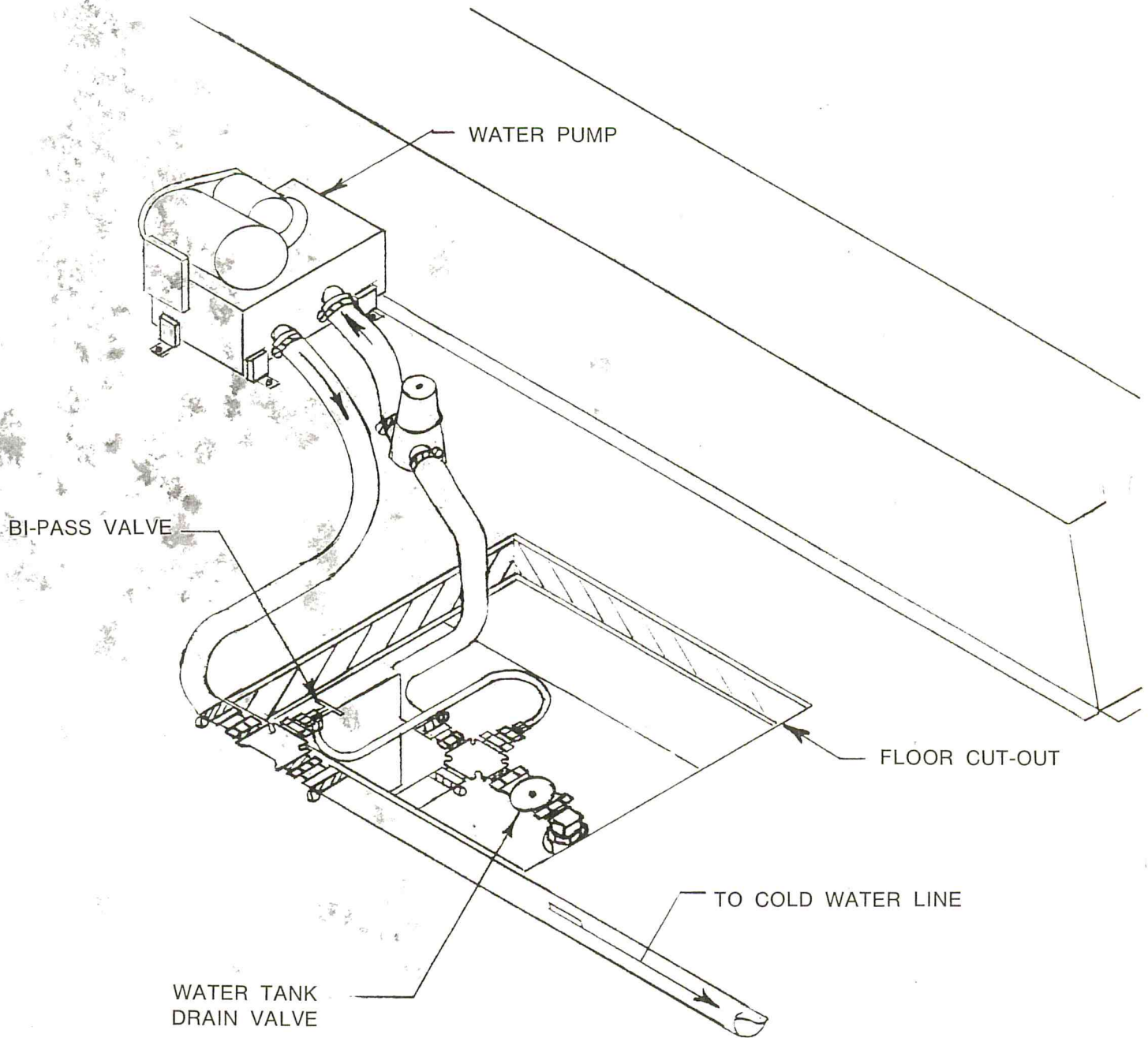

TABLE C
PROTECTION FROM FREEZING WEATHER
DOUBLE BED MODELS



SECTION VIII

TABLES, DIAGRAMS, AND ILLUSTRATIONS

TABLE A SUSPENSION SYSTEM CAPACITIES

<i>Model</i>	<i>Maximum Cargo Weight</i>	<i>Gross Axle Weight</i>	<i>Gross Vehicle Weight</i>	<i>Recommended Hitch Weight</i>
25 FT. TANDEM	1,875	6,370	7,238	12%-15%
28 FT. TANDEM	1,615	6,370	7,238	12%-15%
31 FT. TANDEM	2,025	7,260	8,250	12%-15%

CARGO may be defined as water, fuel, luggage, supplies, and optional equipment not installed at the factory.

GROSS AXLE WEIGHT RATING is the maximum total weight on both axles. This weight can be checked on any scale that will accommodate all four trailer wheels at the same time. GAW can be checked with the trailer coupled to the tow vehicle with an equalizer hitch.

GROSS VEHICLE WEIGHT is the maximum recommended weight of the trailer when a minimum of 12% of the trailer weight is carried by the hitch. This weight can be checked on any scale that will accommodate the four trailer wheels and the jack post at the same time.

Hitch weight can be determined by placing only the jack post on a platform scale and adjusting it until the trailer is level. Trailer must be disconnected from towing vehicle.

THE RECOMMENDED HITCH WEIGHT is represented as a percentage of the Gross Vehicle Weight. As cargo weight is added to the coach it may be necessary to place heavier objects forward to preserve the proper weight distribution.

TIRE INFLATION PRESSURES, for the gross axle weights shown above are:
 GENERAL TIRE JUMBO 780, H78-15, Load Range "B"32 PSI
 GENERAL TIRE JUMBO 780, L78-15, Load Range "D"40 PSI
 MICHELIN L 78-15, Load Range "D"65 PSI
 GENERAL NYGEN 700 x 15, Load Range "D"60 PSI

Trouble Shooting (cont'd)

- e. Heater element overheated. Energy cut-out was activated. Remove electrical box cover on heater jacket and depress red "RESET" button. NOTE: It may be necessary to temporarily disconnect copper water line to facilitate removal of cover plate.

WATER PUMP

Trouble: Water from city pressure passes back through the pump and causes water storage tank to overflow at fill spout.

Cause and Remedy:

- a. Improper seating of pump valves. Drain or pump water system dry. Remove, disassemble and clean dirt from valves. Inspect for damage and replace. When reassembling be sure to tighten the four bolts evenly to prevent cracking the pump base. All hose clamps should be tightened securely.
- b. Bi-pass valve may not be completely closed. Tighten as needed.

Trouble: Pump runs, but does not deliver full supply of water.

Cause and Remedy:

- a. Dirt in filter. Clean and replace. See instructions in Section IV, Item 4.
- b. Severe kinking in pump hose. Adjust the hose to eliminate the restriction.
- c. Water tank empty. Refill.

Trouble: Pump will not run.

Cause and Remedy:

Blown fuse. Check fuse block at front of coach. Replace with correct size fuse.

Trouble: Pump runs when no water is being used.

Cause and Remedy:

- a. Bypass valve is open, allowing water in system to circulate. Close valve.
- b. Leak in water system. Examine all plumbing lines and water heater drain.

STEREO TAPE PLAYER

Trouble: Excessive hum.

Cause and Remedy:

- a. Blown fuse between batteries and trailer 12-volt electric system. Replace fuse or fuses.
- b. Loose wire connections at battery or at fuse block. Tighten connections. Batteries must be in the 12-volt circuit to reduce hum.

Trouble: Does not play.

Cause and Remedy:

Blown fuse. Check the line fuse located behind the player, and the fuse block at the front of the coach.

Trouble Shooting (cont'd)

CONVERTER

Trouble: Loss of D.C. power.

Cause and Remedy:

- Power cord may be disconnected. Check service receptacle and plug.
- Breaker off. Check breaker box in coach closet and reset.

Trouble: Circuit breaker feeding power converter circuit continues to break.

Cause and Remedy:

- Bad diode in converter. Have converter replaced or repaired.

Trouble: Converter does not charge batteries.

Cause and Remedy:

- Blown fuses. Disconnect wire from battery positive post. Replace fuses, then reconnect wire.

FUSES

Trouble: Replaced fuses continue to blow.

Cause and Remedy:

- Loose wiring connections. Tighten all wire clamps and terminals.
- Poor fuse contact. Inspect fuse clips to be sure they are not bent. In the battery circuit two 20 amp fuses are used in parallel. When replacing these fuses, disconnect the wire from the positive battery terminal to prevent throwing the full load into a single fuse while making the replacement.
- Improper fuse size. See page 10 for recommended fuse sizes.
- Incorrect wiring of batteries or fuse block. Refer to wiring illustration on page 10.
- Short in wiring. See nearest Avion Dealer.

REFRIGERATOR – DOMETIC

Trouble: Refrigerator does not freeze satisfactorily.

Cause and Remedy:

- Jet orifice clogged. Remove burner barrel, unscrew jet and blow clear or wash in alcohol. **Do not** use a pin or wire to clean orifice.
- Check the leveling of the refrigerator.
- Flame has gone out. 1) Gas in the bottle is used up – refill. 2) Feeler point of the flame failure device is not heated enough by flame – refer to figure “5” in the Dometic Instruction Booklet. 3) Clogged by-pass screw – clean or exchange it.

- Air circulation around cooling unit is restricted. Be sure that refrigerator is properly ventilated.
- The evaporator is heavily coated with frost. Defrost by setting thermostat to zero.
- Flue baffle not inserted into the central tube of the cooling unit.
- The thermostat is incorrectly used. See paragraph on thermostat in the Instruction Booklet.
- Gauze in burner head clogged. Clean.
- Burner damaged. Replace.
- Burner may be dislocated. Relocate.
- Wrong gas pressure at burner. Have pressure checked at burner and at the gas bottle. Pressure at the burner must not fall below 11" W.C. when thermostat is set on “Max”.
- Improper operation of the thermostat. Thermostat will have to be changed.

Trouble: Odor from fumes.

Cause and Remedy:

- The flame touches side of the boiler due to dislocation of the burner. Relocate. Burner dislocation may also cause smoke and discoloring of walls and ceiling.
- Burner damaged. Replace.
- The flame touches flue baffle. 1) Burner damaged. Replace. 2) Flue baffle too low. Correct the position of baffle.
- Flue tube is dirty. Clean flue as follows: Remove burner barrel and cover the jet. Remove flue top and baffle. Clean flue with special flue brush. Clean baffle and burner head before putting them back in place.

TIRES

Trouble: Overheating or wearing unevenly.

Cause and Remedy:

Improperly inflated. Refer to inflation information on page 16.

Trouble: Flat tire.

Cause and Remedy:

On a tandem axle coach with the exclusive chain hooks, supplied as standard, it is possible to “chain up” the axle with the flat and drive to a tire repair station on three wheels. The flat tire may be left on or removed from the trailer while “limping in” when the axle is chained up. By utilizing the chain hooks it is also possible to remove a flat tire and replace it with a spare when no jack is available.

continued on next page

AIR CONDITIONER (cont'd)

Coleman Recreational Vehicle Service Center. Refer to the service center list provided with each air conditioner.

19. TV ANTENNA (Opt.)

*Warranty Registration Card
mailed 5-8-74*

The all channel SKYLINER TV Antenna operates entirely from inside the coach. **BE SURE TO CHECK THE AREA OVER THE ANTENNA** before attempting to operate. To raise the antenna pull the crank down and rotate counter clockwise to the stop.

To rotate the antenna push crank up with turning motion engaging driving pin – rotate until best picture or signal is received.

To lower the antenna rotate clockwise to the stop-pull crank down and rotate clockwise to the stop.

Your Skyline TV Antenna has two convenient outlets. One is located at the galley sink and one in the bedroom area. Each is combined with a 12 volt utility outlet.

RAISE THE ANTENNA BEFORE ATTEMPTING TO RAISE THE REAR CEILING VENT COVER. BE SURE TO LOWER ANTENNA BEFORE TOWING THE COACH.

The antenna is warranted for a period of 90 days, according to the conditions listed on the warranty card. Warranty service, parts and information may be obtained from **BRAUND MANUFACTURING COMPANY, 730 East Michigan Avenue, Battle Creek, Michigan 49017.** The telephone number is: AC 616 963-3855.

20. OGDEN WATER PURIFIER (Opt.)

The Ogden Water Purifier is designed to remove harmful bacteria, odors and impurities from your drinking water. It uses replaceable cartridges which have a capacity of from 200 to 500 gallons. The cartridge should be changed when the water begins to run slowly.

Use the following procedure to install a new cartridge:

1. Turn off water supply and open nearby water faucet to relieve the water pressure.
2. Remove wing-nut and cover from the purifier.
3. Remove used cartridge and clean inside of unit with stiff brush and rinse thoroughly.
4. Clean upper and lower seals in cover and bottom of purifier body. Replace seals if broken or deformed.
5. Install new cartridge in purifier and replace cover and wing-nut.
6. Turn on water and allow it to enter unit and wet the new cartridge.
7. After cartridge is wet, tighten wing-nut firmly by hand. **DO NOT USE A WRENCH.**
8. Allow water to flow from purifier for about 5 minutes for purposes of activation.

Gasket sets and replacement cartridges, Type SM-1, may be obtained from many trailer supply stores, from many

Avion Dealers, or from:

Avion Service Corporation
1576 East Empire Avenue
Benton Harbor, Michigan 49022
Western Ogden Purifier Corporation
7063 Vineland Avenue
No. Hollywood, California 91605

21. SOUND SYSTEMS

If your AVION is equipped with a Skyliner T.V. Antenna it will have a special coupler connecting the radio antenna lead in cable to the T.V. antenna. This coupler is automatically installed with each T.V. antenna, adapting it for use with both AM and FM radios.

Antenna lead-in cable, stereo speaker wires and a 12 V.D.C. power cable are all located in the overhead cabinet at the front of the trailer. The antenna cable has a standard plug on the end, ready to insert in the radio jack. The 12 volt D.C. wires are connected directly to the radio or tape player, with a 4 amp fuse inserted in the positive lead.

For full stereo, four speakers are used. They are located at both ends of the front cabinet and in a rear-facing closet panel on each side of the coach. Color-coded pairs of wires connect to each of the speakers.

A speaker cut-off switch is located in the bottom of the front overhead cabinets. It controls the two speakers in the bedroom area.

STEREO RADIO-TAPE PLAYER (Opt.)

The Model C-975 Audiovox sound system combines AM, FM and MULTIPLEX RADIOS with an 8-Track Tape Deck. Four 5¼" speakers distribute the sound to all areas of the coach. Operating instructions are provided with each unit.

Tape cartridges should be protected when the coach is not in use. Do not leave a tape in the player. Place cartridges in a plastic bag and store in a place where they will not be exposed to excessive heat. Avoid storing near the speaker magnets or other strong magnetic field, as this may cause distortion or erasure of the tape.

The Audiovox Model C-975 is warranted against defects in material or workmanship for a period of 24 months, according to the terms and conditions of the warranty certificate. Warranty service or the name and address of an approved warranty station, may be obtained from **AUDIOVOX CORPORATION, 300 Denton Avenue, New Hyde Park, New York.**

AM-FM RADIO (Opt.)

The **Model C-505** radio features all transistorized push-button tuning. Four 5¼" speakers distribute the sound to all areas of the trailer. The radio is warranted for a period of 90 days according to the terms of the warranty certificate. Warranty service, or the name and address of an approved warranty station, may be obtained from **AUDIOVOX CORPORATION, 300 Denton Avenue, New Hyde Park, New York.**

Running Gear (cont'd)

sion. The rubber springs require no lubrication. They may be washed with soap and water to remove road dirt.

Wheels

The wheels on each coach are electronically balanced on the drums. Should it be necessary to remove a wheel from a drum, place a reference mark on both parts so that the wheel may be remounted in the original position. This precaution will maintain the factory balance, as long as the tire is not removed from the wheel.

The tandem running gear is equipped with chain hooks which make it possible to change a flat tire without the aid of a jack, or to "chain" the axle so that you can drive with the tire left on, or removed, to a tire repair station. For instructions on how to use this exclusive feature see "Flat Tire" in Section VI of this manual.

All suspension mounting bolts should be checked periodically to be sure that they are tight. The wheel bearings should be packed with grease and adjusted every 5,000 miles. Wheel lug bolts should be torqued to 100 lbs. Check these at the end of the first 100 miles and before starting each trip.

Brakes

The 25-ft., and 28-ft. models are equipped with 10" electric brakes. The 31-ft. model is equipped with 12" brakes. Adjustment of the coach brakes should be done by a dealer's service department, or by a competent automotive mechanic. The method of adjustment is the same as most automotive brakes.

The axle system on your coach has been designed to provide adequate cargo capacity.

Tires

Your new trailer is equipped with General Tires, known for over 50 years as a manufacturer of high quality tires. These tires are built to give you long trouble-free mileage at highway speeds in long haul service.

The 31 foot model is equipped with L78-15 Jumbo 780 tires, load range D. These tires should be inflated to 40 PSI.

The 25 foot and 28 foot models are equipped with H78-15 Jumbo 780 tires, load range B. These tires should be inflated to 32 PSI.

Strong glass belts under the tread provide increased tire mileage and more resistance to impacts and punctures. Deeper, wider tread gives you a wider tire footprint for improved traction on wet or dry pavement, giving greater control at all normal driving speeds and sure handling response.

The Belted Jumbo 780 featuring a wide flat tread provides a 9 rib tread for fast stopping action. The single wide strip styling complements your new AVION Coach.

CHECK TIRE PRESSURE BEFORE EACH TRIP. DO NOT OVER-INFLATE. Safety skids are available

as an optional item to prevent excessive damage to tires, wheels and drums when a flat tire occurs.

Tire sizes and load ratings used as original equipment on trailers have been approved by the General Tire Development Department. Maximum load capacities for each coach size are shown in Table A, Section VIII of your manual.

GENERAL TIRE NEW PASSENGER TIRE GUARANTEE

If any new original equipment General passenger tire fails from defects in workmanship or material, we will either repair it free of charge or replace it with a new General tire of like quality.

The adjustment price will be based on the purchaser's cost of the guaranteed tire equivalent to the percentage of tread depth used, plus state and local taxes.

Prorated adjustments will be based on the tire having delivered its full tread life when subjected to tread wear indicators.

This warranty is applicable only to the original purchaser and claims must be submitted only to authorized General Tire dealers.

If you should require an adjustment on a faulty or defective tire, take the tire to a General Tire Store, and they will make an adjustment according to the terms and conditions of the guarantee.

DO NOT THROW A DEFECTIVE TIRE AWAY. You must have it to receive an adjustment.

When storing coaches for an extended period of time, block up the axles to remove weight from the wheels and prevent flat spots from forming on the tires. Reduce tire pressure to 10 pounds. Re-inflate to recommended pressure before removing blocks.

15. CONVERTER

This coach is equipped with a Model PD-708 converter. It is located on the floor at the right front corner of the coach. It provides 12-volt direct current whenever the power cord is plugged into a standard 110-120-volt, 60 cycle AC source. The converter has two output circuits. One circuit supplies the energy for the 12-volt lights and motors in the coach. The second circuit provides the energy to recharge the batteries, as needed. This model is designed to provide maximum power even when the batteries are not installed in the coach.

The converter has a built-in switching relay which isolates the self-contained batteries whenever the power cord is connected to 115-volt AC source.

When the power cord is disconnected the relay automatically connects the two coach batteries to the interior lighting system so that service will not be interrupted.

Both the converter output circuits are protected with

Water Closet (Toilet) (cont'd)

because the small pedal actuates the water inlet valve; and the rim storage is filled, when both pedals are depressed.

- D. Release both foot pedals. This closes the slide valve and stops usage of fresh water, and the bowl refills automatically from the rim storage.*
3. Directions for Flushing with the Water Saver Package Installed:
 - A. Hold the hand spray in ready position over the bowl.
 - B. Depress thumb button on the hand spray.
 - C. Depress both foot pedals, thus opening the slide valve, dropping the waste into the holding tank, and sending fresh water through the hand spray.
 - D. Spray the bowl clean with the hand spray. Release the foot pedals, thus closing the slide valve, and shutting off the water flow through the hand spray. Be sure all paper is flushed from the bowl. If wedged in the valve seat, paper will prevent sealing.

The Aqua Magic Toilet does not require lubrication. Ordinary household cleaners may be used for routine cleaning. Common toilet bowl cleansers may be used; however, they should be flushed on through the system within four hours, and should not be left in the holding tank for any extended period of time.

The Thetford Toilet is warranted by the manufacturer for a period of two years, according to the terms and conditions of the Guarantee statement. Warranty service and parts may be obtained from: **THETFORD ENGINEERING CORPORATION, 6539 Jackson Road, Ann Arbor, Michigan 48103.** Their telephone number is AC 313 426-4612.

10. WASTE HOLDING TANKS

Your trailer is equipped with two holding tanks; a waste holding tank and a rinse water holding tank. Each has a 25-gallon capacity.

The waste holding tank collects only waste from the toilet stool. The rinse water tank collects the liquids from the tub and from both lavatory and galley sinks.

The two tanks are located adjacent to each other and drain through a single sewer hose connection. Each tank is equipped with a valve. These are located behind an access door near the rear of the coach on the left side.

The rear-most valve controls the flow from the waste holding tank.

It is not wise to keep this tank valve open. The volume of water used with each flush may not be adequate to flood away all the solids. The result can be a build-up

that is difficult to remove. Keep the dump valve closed, run about 2" of water in the tank before using and flush every few days.

To flush, open the valve by pulling the handle all the way out. This will send a large volume of sewage through the drain hose at one time, setting up a swirling action that will flush away the solids.

The drain valve nearest the front of the coach controls the flow from the rinse water tank. This valve may be kept open when your drain outlet is connected to a sewage disposal system. Keep the valve closed to retain the rinse water when no disposal facilities are available.

A drain cap is provided to prevent accidental dumping of accumulated waste. Cap should be in place while traveling, but must be removed before opening either tank valve.

When draining both tanks open the waste tank valve first. After this tank has been drained and the valve closed, open the rinse water tank valve. The flow of rinse water will aid in flushing both the drain outlet and the sewer hose.

When using the coach in freezing temperatures, a permanent type anti-freeze may be added to the waste holding tanks. Use an Ethylene Glycol type anti-freeze. Follow the directions on the container to obtain the desired protection.

When preparing to travel, flush and refill with 2" of water. Add a commercial cleaner if desired. Be sure that the tank valves are closed and locked with the wire clips to prevent accidental opening while driving.

When two coaches are traveling together it is sometimes necessary to share water and/or sewage disposal facilities. A standard garden hose "Y" fitting, available at any hardware store, will permit two to share a single water source. Connect the "Y" directly to the coach water inlet faucet. Trailer supply stores can provide a sewage connection "Y" that will also permit sharing a single sewage disposal system.

11. GAS-ELECTRIC REFRIGERATOR

Lighting instructions for the refrigerator are located on the inside of the panel below the refrigerator door. These instructions are duplicated in the Instruction Booklet that is supplied with each unit.

It is important that the refrigerator be level in all directions for proper operation. Place a small level on the freezer shelf and observe with the aid of a small mirror. For leveling instructions refer to Section II of this manual. For best results operate the refrigerator on "gas". Some locations have wide fluctuations in the line voltage which can cause unsatisfactory operation when switched to "electric".

Gas System (con't)

Flipping the lever to the opposite position will change the Reserve cylinder to the Service cylinder. It will also cause the red indicator to disappear. Close the valve of the empty cylinder before removing it for refill. After refill and replacement, it will become the Reserve cylinder. The next time the red indicator appears the process should be repeated. **NOTE:** If the system is under heavy load, particularly in cold weather, the Service cylinder pressure may drop enough to indicate Reserve, even though there is fuel in the Service cylinder. Do not consider the cylinder exhausted until it shows red (Reserve) under a light load.

Testing for Gas Leaks

All gas line fittings, except those at the individual appliances, are located outside the coach. Several connections will be found under the coach, where the main gas line branches off to supply the individual appliances. These gas lines and fittings should be inspected and tested periodically for possible damage and leaks. Brush or spray a soap suds solution over all fittings and any damaged areas in the line. The bubbles will grow in size to indicate the presence of a leak.

If the odor of gas is detected inside the coach, extinguish all flames and test for leaks. If the leak cannot be detected, turn off the valves on both gas bottles and see your dealer's service department, or a competent gas appliance service man. **DO NOT CONTINUE TO USE YOUR GAS SYSTEM UNTIL THE LEAK IS LOCATED AND ELIMINATED.**

The gas appliances in your coach are designed and adjusted to use L.P. gas. Propane gas is the most common type. Butane may be used but will not vaporize, or turn to gas at temperatures below 31°F.

7. WATER HEATER

Your coach is equipped with a 6 gallon Bowen combination gas-electric water heater. It is located on the left side, near the rear of the coach. An exterior door is provided to give access to the gas controls and the drain valve.

Electric Operation

The heater is equipped with a 1,000 watt, 115-volt element for operation on electrical current. The heater is equipped with a power cord and plug that connects to the adjacent receptacle. A convenient "ON-OFF" switch is located on the electrical box, fastened to the heater jacket. It is accessible from inside the trailer.

DO NOT TURN THIS SWITCH ON UNLESS THE HEATING ELEMENT IS COVERED WITH WATER. Failure to do so may burn out element and void warranty.

Gas Operation

LIGHTING PROCEDURE

1. The water heater should be filled with water, gas bottles should be full and valves open.
2. Gas cock dial (A) should be in "off" position.
3. Wait sufficient length of time to allow gas which may have accumulated in burner compartment to escape. (at least 5 minutes if re-lighting).
4. Turn gas cock dial (A) to "pilot" position.
5. Depress and hold reset button (B) while lighting pilot burner (E). Allow pilot to burn approximately one-half minute before releasing reset button. If pilot does not remain lit, repeat operation allowing longer period before releasing reset button.
6. Turn gas cock dial (A) to "on" position and set temperature dial (C) to desired temperature.
7. To shut down the heater, turn gas cock knob to "off".

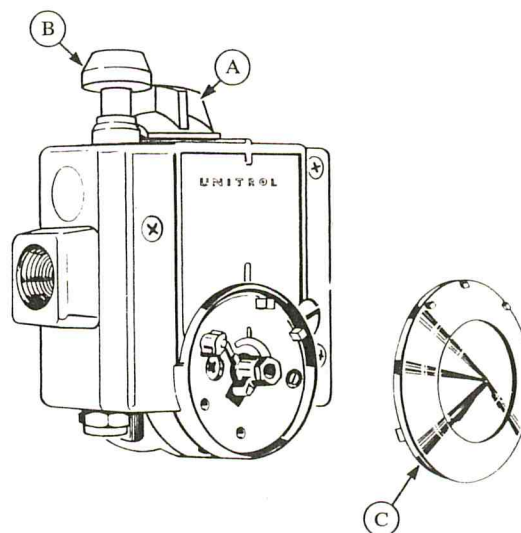

PILOT AND MAIN BURNER ADJUSTMENT

Your BOWEN WATER HEATER has been adjusted at the factory with proper air and gas mixture for both pilot and main burner. Should it be necessary to change these adjustments, use the following procedure:

1. **Gas Line Venting:** When unit is new or has run out of gas it may be necessary to repeat steps 4 and 5 in the LIGHTING PROCEDURE to remove air in the gas line. It is recommended that appliances such as the range or space heater be lighted first. This assures a supply of gas in the main gas line.
2. **Main Burner Adjustment:** Proper combustion de-

continued on next page

Electrical Systems (cont'd)

senses the state of the battery charge and will automatically charge and shut off as required. The converter is protected by a built-in circuit breaker. If a short, or overload is occurring, a 7 to 10 second clicking sound will be heard as the automatic reset breaker clicks off and on. The converter may be disconnected from the 120-volt source by removing the cord from the wall outlet adjacent to the unit. The converter is located on the trailer floor at the right front corner.

Two fuse blocks are provided to protect the 12 volt system. They are located inside the couch, underneath the front shelf. Circuits and fuse sizes are shown below.

The battery-to-converter circuit is protected by two 20 A. fuses in parallel. Both fuses must be in place at all times so that the load is divided between them. Two extra clips are provided for spare fuse storage.

12-VOLT INTERIOR LIGHTING SYSTEM

A 12 volt utility, or cigarette lighter, outlet is provided in the bathroom. If the trailer is equipped with a T.V. antenna an extra 12 volt outlet is provided at each antenna jack.

Use #1141 12-volt bulbs for ceiling and cornice light replacement. Clear bulbs are available at auto service stations. Frosted bulbs may be obtained from Avion Dealers, or Avion Service Corporation.

Replacement bulbs for the two 12v. recessed lights under the front end cabinet are G.E. Part No. 25 R 14 SC/SP. These are available from Avion Service Corporation.

A patio light receptacle is located on the exterior of the coach on the door side. It is a polarized single outlet with waterproof screw cap. This receptacle is wired for 12

volts and controlled by a switch adjacent to the entrance door. The entrance door light is controlled by the same switch.

LaGrande models are provided with a dimmer switch for the living room ceiling light. Push in on the switch knob to turn the light on or off. Turn the knob to adjust brightness when the trailer is connected to 115 volt service. The dimmer does not work when the trailer is operating from the self-contained batteries.

Two 18" ceiling vents are provided for maximum air circulation in the living and bedroom areas. Both are equipped with power fans. A 6" exhaust fan is installed in the ceiling of the bathroom. It is opened by pushing the handle upward and closed by pulling it down. Do not operate fan motors unless vents are fully opened.

The bathroom mirror is illuminated by two fixtures, and hinged at the top to allow adjustment. Be sure it is securely latched for traveling.

(C) **Interior 120-volt** — The numerous wall outlets in your coach are located to provide convenient electricity for the various 110-120 volt appliances such as an iron, toaster, percolator, etc. These outlets can be used whenever the 25 ft. Power Cord is plugged into a 120-volt AC source. The power cord is stored in a compartment on the left side of the trailer. When connecting it to an outlet, arrange the cord so that the weight of it does not cause a poor connection. The cord storage door has a slot in it so that the storage door may be kept closed while the cord is in use. An exterior outlet is located in the drop door compartment located near the rear of the trailer on the right side.

The 120-volt system is protected by circuit breakers. These are located in a box at the back of the bathroom closet. The main breaker is 30 amps. Turning it off will disconnect all 120-volt wiring in the trailer. Separate breakers are provided for: (1) Appliance Circuit; (2) Air Conditioning Circuit, & (3) General Purpose Circuit.

5. WATER SYSTEM

Your Avion is equipped to provide water service from a city water system or from the self-contained water tank.

Connection to a city water supply is made through a water hose connected from the city supply to the water fitting on the trailer. This fitting is located in the storage compartment on the left side of the coach. The hose may be stored without disconnecting it. A pressure reducing valve protects against excessive city pressures.

The molded plastic fresh water tank is located below the floor at the rear axle. A hot air duct connects the tank compartment with the forced air furnace for cold weather operation.

A cut-out in the trailer floor provides access to the tank fittings and drain valve. In twin-bed models the opening is located under the left or off-door bed. On double bed models the opening is under the double bed.

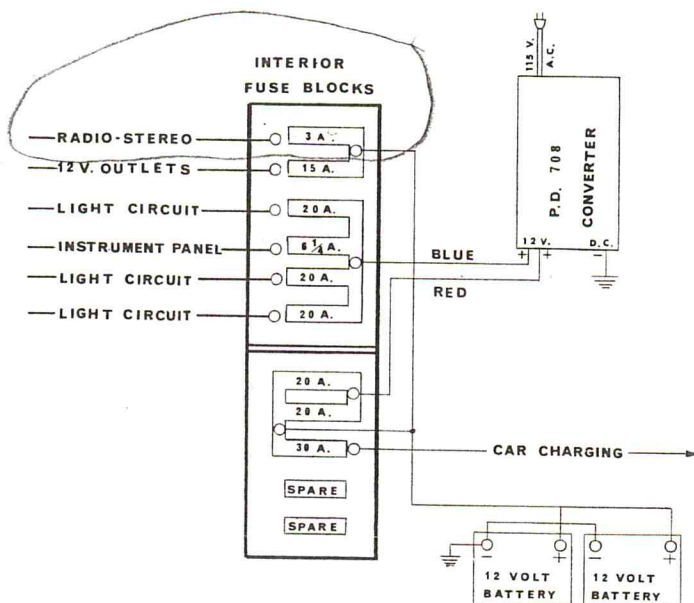

CARE AND CLEANING

Windows — All flat windows are tinted safety glass. They may be cleaned with any type of glass cleaner, or with soap and water.

The two curved front windows are acrylic plastic. They should be dusted and cleaned with a damp cloth or chamois, wiping the surface gently horizontally. Wash with a mild soap or detergent and water. Use as much water as possible, applying with a clean soft cloth, sponge or chamois. The best method of drying is with a clean damp chamois.

You can protect them with a good grade of commercial wax. Apply and bring it to a high polish by rubbing with a soft dry cloth.

Cabinets and Woodwork deserve the same care as the furniture in your home. A furniture wax or polish will aid in maintaining the fine factory finish. Upper cabinet doors are equipped with a single-arm friction brace. Tighten the adjusting screw to increase friction if the door does not stay in open position.

Interior Walls are covered with vinyl. They may be cleaned by washing with a mild soap or detergent and water. **DO NOT** use an abrasive cleaner or a solvent as it may damage the vinyl or dull the finish. Avoid exposure to concentrations of propane or natural gas. The bathtub should have the same care as the interior walls.

Draperies, bedspreads and wall pads are of high quality synthetics and should be dry cleaned.

Carpeting is 100% polyester. It may be cleaned with any good grade of foam carpet cleaner. Follow the instruc-

tions on the container. The Johnson Wax product "Glory" has been found to work well.

Upholstery is soil resistant treated to minimize spotting. (Sponge up spills immediately.) Soiled areas may be cleaned with mild detergent and water.

Exterior Skin of anodized aluminum should be washed and cleaned in the same manner that you care for your automobile. Wash with a mild soap or detergent. Road tars may be removed with *kerosene*, *turpentine* or *naphtha*.

Follow the cleaning with a soap and water rinse and then dry with soft, absorbent material.

CAUTION: When using these liquids, do not allow them to get on the window panes. Do not use cleaners containing caustic or ammonia.

A polish may be used on the exterior surface to provide additional protection. A cleaner-wax-polish type material should prove satisfactory, if the manufacturer's instructions are followed. Be sure to do the polishing in the shade, rubbing the same direction as the grain in the metal.

A more permanent protection may be obtained by applying a coating of clear wax after the polishing is completed.

Exterior seams should be examined periodically for holes or cracks which may result from shrinkage of the sealer after prolonged exposure to the elements. The sealer for all exterior seams of your Avion carries the brand name of "Ten-X". It is manufactured by Electo-Cote Company, Minneapolis, Minn., and can be purchased from most trailer dealers and automotive supply stores.

SECTION IV

PROTECTION FROM FREEZING WEATHER

1. Level the coach and disconnect water supply hose. The water lines in your coach have been installed with a slope to permit gravity draining. Inspect these lines to be sure they have not been bent out of position. Water lines from bath lavatory should slope toward water heater, draining through the heater tank drain. The water lines from the galley sink should slope to the water tank drain valve.

2. Drain the water storage tank by opening the drain valve which is located at the end of the tank. The storage tank may also be drained by opening one or more of the faucets and pumping the water into the sinks, where it will drain through the sewer hose.

3. Shut off water pump at switch, open all faucet valves, and drain water heater tank. The valve for this tank can be reached by removing the panel on the outside of the water heater. Be sure that the water heater has been turned off before draining. gas / on 120V Elec

4. Remove water from the stool by holding both foot pedals down and allowing the system to drain. Be sure the water supply has been turned off and that the cold water faucet in the bathroom sink is open. This will vent the water line to the stool and allow it to drain.

Open the drain valve at the back of the stool. Hold stool pedals down or open sink faucets to vent the line. BE SURE TO CLOSE THIS VALVE BEFORE USING THE WATER SYSTEM.

Lay the water saver spray gun on the floor and put a rubber band around the thumb button to hold the valve open and allow it to drain. The spray head may also be removed from the hose to prevent damage from freezing.

Should water accidentally be left in the stool, damage may be prevented by allowing the unit to thaw out at room temperature before using. **DO NOT ATTEMPT TO FLUSH A FROZEN STOOL.**

5. Open tub valve and shower head valve button to drain the shower head.

6. Open both holding tank valves and drain tanks completely. (Drain should be connected to sewer for this operation.)

7. Raise the front end of the coach as high as it will go by cranking the jack all the way up and allow water to drain. Then crank jack to lowest position and allow water to drain. Return to level position.

8. Use suction pump to remove water from traps, or pour about one cup of any Ethylene Glycol type anti-freeze in each of the three traps — one in the kitchen sink, one in the bathroom sink, and one in the bathtub. Use caution to avoid spilling the solution on plastic surfaces where discoloration may occur. **DO NOT** use an alcohol base anti-freeze.

9. If your trailer is equipped with a purifier, remove the cartridge, allow to dry and store until ready to use again.

10. The water tank drain is located under the left bed in twin-bed models. To drain the tank, open the cold water faucets and the bi-pass valve — See Illustration B. Open the tank drain valve and allow to drain. Be sure to close both valves when preparing coach for use.

In double bed models the water pump, bi-pass valve and water tank drain are located under the double bed. Refer to Illustration C in Section VIII of this manual for identification of the various connections and valves. Follow the instructions given in the preceding paragraph.

To drain the pump open both the water tank drain valve and the bi-pass valve. Turn the water pump on and allow the pump to discharge any water remaining in it. Turn pump switch off but keep both valves open to allow gravity draining of any water that may be left in the lines. Close both valves when preparing coach for use.

11. Insert a stiff wire or slender rod into the water inlet fitting which is located in the hose storage compartment. Push inward to release the spring tension in the check valve and allow water to drain from it. Be sure faucets are open to vent the line.

12. If it is practical, remove the batteries and store in a warm place during freezing weather. If the batteries are kept on the coach, be sure that they have a full charge to prevent freezing.

13. **CAUTION**—Do not travel with the anti-freeze solution in the tub or lavatory drains unless the drain plugs are securely inserted to prevent the solution from splattering on the plastic.

SECTION II

TOWING

1. Install side-mount rear view mirrors on the towing vehicle. Adjust them to show the corresponding side of the trailer and as much of the adjacent area as possible. The center mirror of the towing vehicle may be used to observe the front of the trailer. If a flat tire occurs on the trailer it will be evident by the angle of the trailer when viewed through the center mirror. Make it a habit to check all three mirrors regularly.

2. Adjust driving speed according to road conditions. Maintain an adequate distance from the vehicle ahead. Keep at least one car and trailer length for each ten miles per hour of speed.

3. Allow an adequate turning radius, particularly in city driving. When making sharp turns remember that the trailer will turn in a smaller arc than the towing vehicle.

4. A correctly adjusted brake control will apply the trailer brakes at the same time, or just slightly before the car brakes are engaged.

In an emergency situation the excessive sway or skidding of the trailer can be brought under control by using the brake control to manually apply the trailer brakes gently. The speed of the towing vehicle should be held steady so that the forward pull of the car and the braking force of the trailer wheels work to re-align the two vehicles.

5. Be sure to allow more time for passing a slower vehicle. Remember that acceleration will be slower with a trailer in tow. Allow more distance before returning to the right lane.

6. Set reasonable driving goals for each day traveling. Make numerous rest stops to stretch and exercise. Avoid driving when tired. Fatigue reduces driver alertness and contributes to accidents.

7. Provide emergency equipment. Include a jack, wheel blocks, flares, a tool kit and a fire extinguisher.



