



**Inside This Issue**

Meeting Minutes.....1-5

Upcoming Events.....6-9

New Releases.....9-10

Members Build Blogs.....10-12

Club "Contest" .....N/A

Interesting Articles.....12-15

New Techniques.....15-25

USA AFV Register.....25

Support Our Vendors.....26

Classified Ads.....27

The Day Room (Editor) .....27

Welcome to the latest issue of our newsletter. We try REALLY hard to publish this each month, but sometimes stuff happens, or you know, CRS flair ups occur. Of course, what's published in this newsletter is probably out of date, known by everyone already, or completely off-topic. Maybe everyone will like the pretty colors, but then your ink cartridge will probably run out after only printing a couple pages. This paragraph is what's known as "filler text", which we needed since we added the snazzy table of contents and this area was kind of empty.

Check out the "Classified Ad" section near the end of the newsletter. This section will give you a space to advertise items you want to barter, swap, sale or trade. Or even a request for research material. Check it out. Contact the seller directly. Note personal email addresses are not listed on the public site. Contact the seller directly via his/her email addresses.

Check out our website for more info & photos:  
<http://www.ampscentralsouthcarolina.org/>



Visit us on Facebook at:  
<https://www.facebook.com/ampscentralsouthcarolina>

**Regular Meeting Minutes, 10 January, 2018**

Our last meeting was held on Wednesday, January 10, 2018 from 6-8 pm at the HobbyTown store in the Publix Shipping Center (North Pointe Shopping Center), Two Notch Road, Columbia (NE). We had 23 members in attendance, including junior member Morgan Cicimurri. The modelers brought 27 models for Show & Tell, plus Daniel Karnes sent pictures of his AFV Club M60A2 "Starship" the same day since he couldn't make the meeting due to work. For the Raffle, we had a Bronco Model 1/35th scale "British Cruiser Tank A34 Comet", kit #CB35010SP, won by Jeff Nelson.

Ralph Nardone also raffled off IPMS I-Con Bags to Tim Darrah, Rebecca Hettmansperger, Michael Child, Tony Abbott, Tom McCoy, and Phil Cavender. Please see our website for photos of the models that were brought in for Show & Tell, the meeting, and the raffle prize.

- 1) Jagdhetzer 38T (Academy Hetzer kit + Kraut-Kits Conversion, Mission Models Paints), 1/35 – Tim Darrah
- 2) OH-6A, F.B. Ripcord (Italeri + Scratch-built Cockpit Parts), 1/72 – Tim Darrah
- 3) King Tiger on a M19/M20 Tank Transporter (Takom & Merit International + Archer Tiger Mix #1 transfers, RB Model Metal Barrels & Towing Shackles, Friulmodel metal Tracks, 0.4mm dia lead wire, Elite metal Turnbuckles), 1/35 – Phil Cavender
- 4) Egyptian Sherman, (The Six-Day War) (DML), 1/35 – Herb Horvath
- 5) IJA Type 89 Japanese Medium Tank OTSU, Gasoline Engine (IBG Models + OKB Grigorov resin Tracks, scratch-made Wire Handles), 1/72 – Bob Kerfonta
- 6) IJN Type 2 (Ka-Mi) w/ Floating Pontoon Amphibious Tank (DML Armor Pro), 1/72 – Bob Kerfonta
- 7) Centaur C.S. Mk. IV British Cruiser Tank Mk. VIII, A27L + British Universal Carrier Mk. II + British Light Utility Car 10HP "Austin Tilly" + British BSA M20 Motorcycle with Military Police + British Army 6 Pounder AT Gun (Tamiya), 1/35 – Michael Child
- 8) WWI German Sturmpanzerwagen A7V (Tauro Model), 1/35 – Kevin Cook
- 9) Napoleonic: British Peninsular Infantry Centre Companies (Victrix), 28mm – Kevin Cook
- 10) American Civil War Infantry (Perry Miniatures), 28mm – Kevin Cook
- 11) Star Wars: Imperial Assault – Storm Trooper, Imperial Guard, Darth Vader (Fantasy Flight Games), ? – Kevin Cook
- 12) T29E3 U.S. Heavy Tank (Takom + 2 Voyager PE sets, Voyager resin 0.50 Cal M2, MasterModel metal 0.30 Cal MG Barrel), 1/35 – Trevor Edwards
- 13) M12 155mm GMC (Academy), 1/35 – Ben Brandes
- 14) M26A1 Pershing (DML + Verlinden resin Vision Blocks, Bison Decals, Bronco Tracks), 1/35 – Ben Brandes
- 15) Diorama: "Map Reading by Lamplight", Panther G (Tamiya + AM Zimmerit, Verlinden Figures, Fence & Gates, Scratch-built Lamp Post), 1/35 – Keith Frape
- 16) Chieftain Mk. 8-2C (Tamiya + Castoff resin upgrades), 1/35 – Keith Frape
- 17) US M48A3 Patton Tank (Tamiya), 1/35 – Morgan Cicimurri
- 18) Pz.Kpfw. IV Ausf. D (Tamiya + Scratch-made Spare Road Wheel Wire Holders, plastic strip Jerry Can Rack, Repainted old model from Barry Nelson), 1/35 – Dave Cicimurri
- 19) SU-100 (Tamiya Lower Hull & Resin Upper Hull + Aber turned Barrel, scratch-built Handles, Modified the Mantlet to SU-100), 1/35 – Dave Cicimurri
- 20) U.S. Tank Destroyer M10 Mid Production (Tamiya + DML Tracks, scratch-built items), 1/35 – Mike Roof
- 21) British Infantry Tank Mk.III Valentine Mk.II/IV (Tamiya + Masterclub metal Tracks, AM Decals), 1/35 – Rebecca Hettmansperger

- 22) M40 155mm SP Howitzer "Two-fer" (Tamiya & AFV Club + Resin copy of the Tamiya Gun), 1/35 – Carl Wethington
- 23) US Medium Tank M4A3E8 Sherman - "Easy Eight" European Theater (Tamiya), 1/35 – Josh Orenstein
- 24) USMC M12 Shotgun 1897 Trench Gun (DML), 1/6 – Josh Orenstein
- 25) East European Well , Wash Basin, Bucket, Box (Royal Model), 1/35 – Bryan Moeller
- 26) Horch Type IA Flak 38, North Africa 1942 (Tamiya + lots of extras), 1/35 – Herb Horvath
- 27) M60A2 "Starship" (AFV Club w/ Full Interior), 1/35 – Daniel Karnes (e-mailed after the meeting)

RAFFLE: Bronco Model's "British Cruiser Tank A34 Comet", kit #CB35010SP, won by Jeff Nelson.

Photo Album on our webpage at: <http://www.ampscentralsouthcarolina.org/meeting-photos.html>

### **Business items:**

- 1) Treasurer's Report: approx. total treasury \$4,472 balance (bank & cash-on-hand).

**Reminder:** Club dues of \$12 per member for 2018 are due starting in January. Still \$12 for adults with no dues for juniors under 18 years old. New adult member dues are pro-rated at \$1 per month for the remainder of the calendar year, first month's meeting attendance excluded. Please see the treasurer, Ralph Nardone, if you need to pay your dues.

**Reminder:** If you pledged to make a \$25 donation to the NACM paver fund that the club has already paid your donation in advance. Please see Ralph or Mike and make your reimbursement payment to the club. **We have a total of \$400 in outstanding pledges that need to be reimbursed.**

**Note:** The mini NACM pavers for each of the individual donors have already arrived, so once you reimburse the club you will receive your mini paver. Mike will have the mini pavers at the meeting. **Bring your money.**

- 2) A note that we were approved to conduct a club visit of the NACM restoration facility at Ft. Benning, GA (Columbus, GA) starting at 9AM on Saturday, 20 January.
- 3) Our June show committee members in attendance updated the club on the plans and coordination for our June **Scale Model Mega-Show**. Members were reminded that it's not too early to start soliciting show award sponsorships and donations.
- 4) Members were reminded that it's not too early to start planning for the Atlanta AMPS show in February.
- 5) The floor was opened for new business:
  - a. There was no new business.
  - b. Note our meeting area has been changed in the store. We're now gathering in the plastic model aisle and no longer have access to the "great square table".

**Regular Show & Tell:** See the meeting photos for all of the completed and works in progress brought to this month's meeting!

## Tentative Agenda, Regular Meeting, 14 February, 2018

Our next regular meeting will be held on Wednesday, January 10, 2018, 6-8 pm, at the HobbyTown store in the Publix Shopping Center (North Pointe Shopping Center), on Two Notch Road, Columbia (NE). This will be our first regular meeting of the New Year.

### Tentative Agenda Business items:

#### 1) Treasurer's Report:

- a. **Total Treasury** = \$4,220.55 (including \$231 deposits and \$387.50 in expenses).
- b. **Bank Balance** = \$\_\_\_\_\_.
- c. **Cash on Hand** = \$\_\_\_\_\_ (with treasurer, to be reported at the meeting).
- d. Pending expenses: \$387.50 for new B-S-G medals, and \$60 for postage.

**Reminder:** Club annual dues are due this month. Still \$12 for adults with no dues for juniors under 18 years old. New adult member dues are pro-rated at \$1 per month for the remainder of the calendar year, first month's meeting attendance excluded.

**Reminder:** If you pledged to make a \$25 donation to the NACM paver fund that the club has already paid your donation in advance. Please see Ralph or Mike and make your reimbursement payment to the club. **We have a total of \$400 in outstanding pledges that need to be reimbursed.**

**Note:** The mini NACM pavers for each of the individual donors have already arrived, so once you reimburse the club you will receive your mini paver. Mike will have the mini pavers at the meeting. **Bring your money.**

2) We had 22 members and their guests in our NACM tour party on Saturday, 20 JAN 18. This was an outstanding and fun opportunity for the club to get up close and personal with the AFVs and related artifacts in the collection. Those who have never been are highly encouraged to participate at the next opportunity they have. It is very likely that our near unrestricted access to the collection will not last forever. In a couple of years, the museum will formally open (tentatively scheduled for 2020), and once the public is on site, AMPS members will probably not be allowed the kind of access that we have now. The next AMPS tour will be this Friday, 16 FEB, in conjunction with the AMPS Atlanta show. If you want to participate you MUST contact Mike Roof ASAP to get included on the tour roster. You will need to be at the tour rendezvous (at Ft. Benning, Columbus, GA) at 7 AM on Friday morning.

3) A short update presented by the show committee members in attendance on the plans and coordination for our June **Scale Model Mega-Show**. Note that it's not too early to start soliciting show award sponsorships and donations.

- a. Venue price has been locked in at \$1,000.00. We are OK for the food trucks. We are OK for Friday afternoon setup. We should have the classroom available for judges training and AMPS judging. Venue security is a "show stopper." No security = no event. RCSD security is recommended at this time.
- b. Free Times print advertising rates have been requested and received:

- i. Cube (2"x2") = \$75
  - ii. 1/8 page = \$145
  - iii. 1/6 page = \$195
  - iv. 1/4 page = \$280
  - v. "Go Cola" 1/8 page est. = \$200
- c. Vendor letters and AMPS and IPMS flyers were distributed at the IPMS Marietta show on Saturday, 10 FEB 18.
- d. Vendor letter and AMPS flyers will be distributed at the AMPS Atlanta show on 16 FEB 18.
- e. AMPS Central SC "Wildcat" B-S-G medals have been reordered. Total cost for 200 medals is \$775 (\$3.89 ea). This was a \$.50 each price increase over our 2015 order (\$678 @ \$3.39 ea). A 50% deposit, \$387.50, has been made, and the order is now being processed. When the order is ready for delivery, the balance of \$387.50 will be due. Deliver is expected within 60 days. Details on the order are available. If you want more info, please ask.

**4) If you're planning on attending the AMPS Atlanta show this weekend, 16-18 FEB, speak up at the meeting and let Mike know.** We'll try to organize some sort of AMPS Central SC dinner, and I don't want to leave anyone out of the loop if they're at the show. Also, if you're at the show, please sign up for a judging shift or two (or three!). Remember that the AMPS Atlanta folks ALWAYS come to our shows and help us out; we should return the favor.

**5) Floor will be open for New Business.**

**6) Following the business portion of the meeting, we'll take a short break for shopping and social mixing.**

**Regular Show & Tell:** to follow the business portion of the meeting & the break/social mixing. Finished models, works in progress and cool new stuff – Bring it all with you to share!

Don't forget the "*meeting after the meeting*" at Schiano's next to the Publix. Make plans to hang out and eat dinner if you can. Everyone's welcome – no special invitation required!

***Mike Roof***

Michael D. Roof

AMPS #1632

Chapter Contact

AMPS Central SC "Wildcats"

**REMINDER:** The HobbyTown store will close at 7:00 pm (1900). This means that all purchases at the store must be made before then so that the cash registers can be closed.

6:15 pm (1810): Admin business and Show & Tell.

6:50 pm (1850): Break: Shopping & Social Mixer. Cash registers close at 8:00 pm.

7:10 pm (1910): Reconvene: Continue Show & Tell: Builds and WIPs

8:00 pm (2000): Meeting ends (officially)

*Regular meetings are held on 2<sup>nd</sup> Wednesdays of each month at 6:00 pm (1800) at the HobbyTown store, 10120 Two Notch Road, Suite 5, Columbia, SC 29223, (803) 736-0959.*

## Up-coming Events

**AMPS Atlanta 2018**, Atlanta Armor, Figure, and Modeling Contest and Exhibition, February 16-18, 2018. Atlanta Marriott Century Center, 2000 Century Blvd., Atlanta, GA 30345, 404-325-0000. **2018 Show Theme: "REFORGER 1969 - 1989"** (Any Tracked or Wheeled Vehicle used by a NATO country during any REFORGER Exercises).

### Again, read carefully!

If you have already made reservations, you are good to go with no further action necessary on your part. If you have not made reservations yet, you will need to make them through the old hotel, the Marriott (see information below), as noted in previous literature. The Marriott will handle, and is handling all reservations through the deadline (31JAN18). After the cut-off deadline passes, all of the reservations will be delivered into the Hilton System where you may claim your room(s) on arrival at the new hotel.

See the AMPS Atlanta Show page for info at:

<http://www.ampsatlanta.org/amps-atlanta-annual-show.html>



**Old Dominion Open**, Richmond International Raceway, 600 East Laburnum Ave, Richmond, VA, 23222. February 24, 2018 - 8:30am to 5:30pm. This event is hosted by IPMS Richmond. The "ODO" is the best February model show and contest in the mid-Atlantic region. It is the annual "kick off" event for in the mid-Atlantic region in a 30,000 sq. ft. facility. More than 40 vendors, 67+ categories, and some very nice awards. More information about this show can be found at Web link: <http://ipmsrichmond.blogspot.com/>

IPMS Richmond Presents  
**Old Dominion Open**  
 Scale Model Show and Contest  
 February 24, 2018

*Old Dominion Open*

**Richmond Raceway Complex**  
 The Henrico Building  
 600 E Laburnum Richmond, VA 23222  
 Doors open 8:30 Registration closes 12:30

**Over 70 Model Categories**  
**Hobby Vendors**  
**Special Awards**  
**Huge Kit Drawings**

See More about IPMS ...  
 Blog: <http://ipmsrichmond.blogspot.com>  
 FB: <https://www.facebook.com/IPMSRichmond>

**AMPS 2018 International Convention**, Hope Hotel and Richard C. Holbrooke Conference Center, Dayton, OH, Phone: (203) 794-0600, May 3 to 5, 2018.  
**2018 Convention Theme: Mishaps (and Oh...).**  
 See the AMPS Homepage for info at: <http://www.amps-armor.org/SiteShows/ShowMain.aspx>

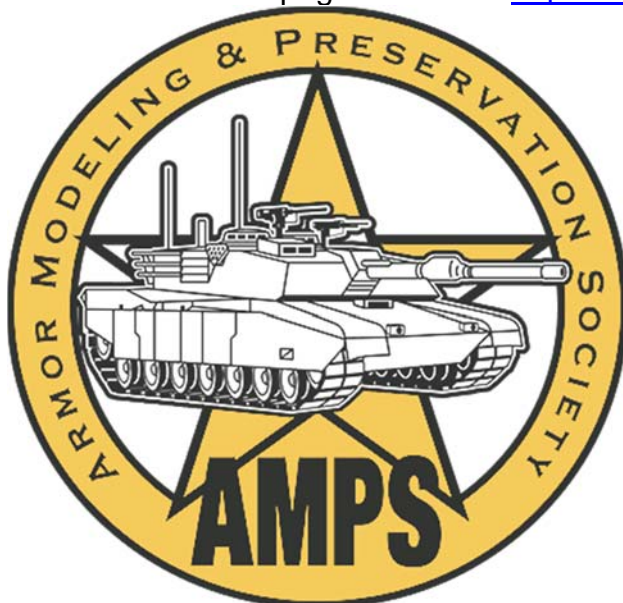

**2018 South Carolina Scale Model MEGA-Show**, co-hosted by AMPS Central South Carolina Wildcats and IPMS/Mid-Carolina Swamp Fox Modelers, will be held on June 22-23, 2018. Location: SC National Guard Armory, 1225 Bluff Road, Columbia, SC, 29201, 803-299-4200. **2018 Show Theme: "I Want My MTV! ~ I love the '80s"** See the following web links for more information: <http://www.ampscentralsouthcarolina.org/> and [www.ipmsmidcarolina.com](http://www.ipmsmidcarolina.com).

**AMPS CENTRAL SC "WILDCATS"**  
in Association with  
IPMS / Mid-Carolina "SWAMP FOX Modelers"

**SOUTH CAROLINA SCALE MODEL MEGA-SHOW**

**Show Theme: "I want my ... TV"**

**9am - 6pm Saturday, June 23, 2018**

**SC NG Armory & SC Military Museum**  
1225 Bluff Road  
Columbia, SC 29201  
I-77, Exit #5  
[www.ampscentralsouthcarolina.org](http://www.ampscentralsouthcarolina.org)  
IPMS Mid-Carolina <https://ipmsmidcarolina.com/>

**Theme Award Eligibility:** AMPS qualifying model subjects that were in-service between 01 January, 1980 and 31 December, 1989, inclusive of all nationalities and locations. Markings, camouflage, and other technical or historical aspects of the model must accurately place it somewhere along that timeline. Subjects that are depicted with technical or historical features or aspects that fall outside of this timeline will be ineligible even if the subject "basis" for that model was existent during some period within the specified timeline. Hypothetical, imaginary or sci-fi model subjects must be based on recognized fictional works that were first published or broadcast during the specified timeline. Neither the specific genre of the fictional work nor the media by which it was published or broadcast will be the basis used to determine eligibility. Models of proposed vehicle / weapon / equipment designs must be based on sources that were first published during the specified timeline. It will be the entrant's responsibility to provide, on request, corroborating information of his or her model's theme eligibility. This may be done by submitting "Research Bonus" information IAW AMPS rules. However, theme eligibility does not require accompanying "Research Bonus" material. The entrant may use some other method to corroborate his or her model's eligibility if it is questioned. In all cases, the entrants must notify the show registrar and Ram Rod of his or her model's eligibility for the theme award during registration. Failure to do so may result in that model being overlooked by the judges. **Any questions about eligibility will be decided by the Chief Judge whose decision will be final. See our website for complete rules and registration information.**

IPMS/MID-CAROLINA SWAMP FOX MODELERS and AMPS/CENTRAL SC WILDCATS  
present the

**I WANT MY**  
**MTV**

*I love the '80s!*

**SCALE MODEL MEGA-SHOW**

SATURDAY, JUNE 23, 2018 9 AM to 6 PM  
SC NATIONAL GUARD ARMORY AND SC MILITARY MUSEUM  
1225 BLUFF ROAD, COLUMBIA, SC

FOR MORE INFORMATION  
visit  
[WWW.IPMSMIDCAROLINA.COM](http://WWW.IPMSMIDCAROLINA.COM) or  
[WWW.AMPCENTRALSOUTHCAROLINA.ORG](http://WWW.AMPCENTRALSOUTHCAROLINA.ORG)



**DownEastCon 2018**, hosted by Eastern Carolina Plastic Modelers, July 14, 2018. Havelock Tourist & Event Center, 201 Tourist Center Drive, Havelock, NC, 28532 (right between/behind the Holiday Inn & Hampton Inn).

**2018 Theme: "The United States Marines"**.

See the following web links for more information: [http://www.ecpmo.com/contest\\_2018.html](http://www.ecpmo.com/contest_2018.html)



## Eastern Carolina Plastic Modelers

Proudly presents

# DownEastCon 2018

## July 14, 2018



1 January 2018





### 2018 New Releases

- **Tiran 4 Late Type, with Full Interior, MiniArt, 1/35th scale, kit # 37029. (Future Release)**



- **Panther Ausf. G Early/Late Versions, with full interior, Ryefield, 1/35th scale, kit # RM-5016. Release date January 2018.**



- **Panther Ausf. A Family, Early, Middle and Late Versions, with full interior, Takom, 1/35th scale, kit #2097 (Early), #2098 (Mid-Late), #2099 (Late).**

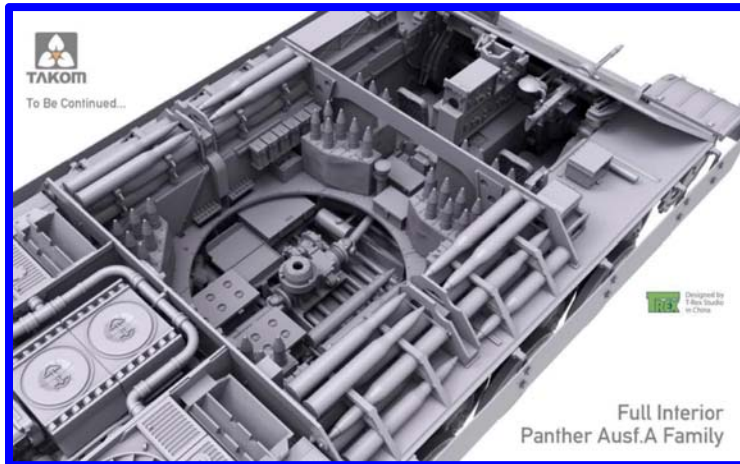

Release date January 2018.

- **Bergpanther Ausf. A, with full interior, Takom, 1/35th scale, kit # 2101. Release date January 2018.**

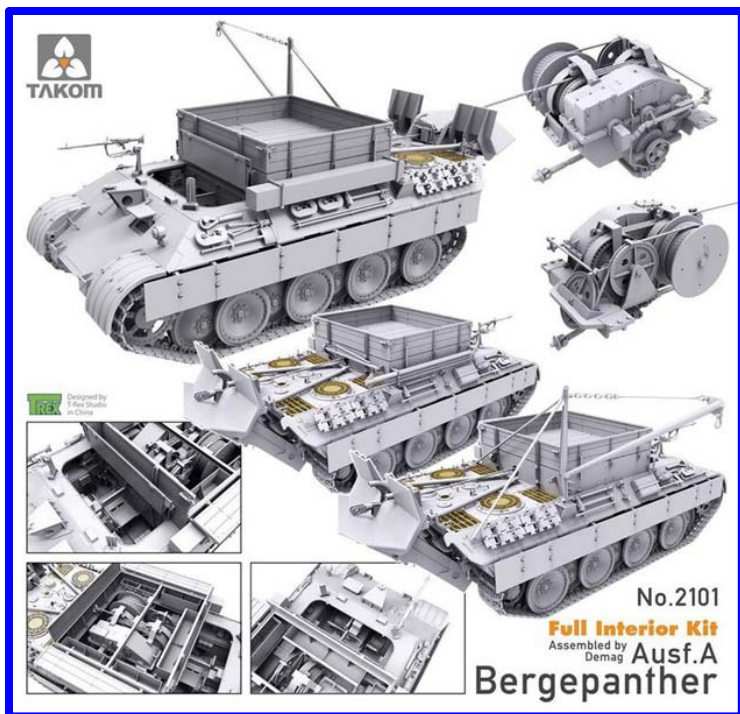

## Members Build Blogs

Build Blogs give an in-depth review of the construction process and allow the builders to share their knowledge. We are fortunate to have some of the members in our club with build blogs on modeling web sites. Please note that due to a recent change with Photo Bucket, many build logs have been impacted and linked photos may not show. While some modelers have/are relinking their blogs to a different photo hosting site, many older build logs and postings on various forums

will likely never show the original linked pictures again and are lost forever. A posting on Missing-Linx provides a (temporary) work-around for Mozilla Firefox and Google Chrome browsers:

<http://www.network54.com/Forum/47211/message/1504035816/PB+-+extension+to+make+photos+viewable+again>

Mike Roof has 2 on Track-Link.com:



MiniArt T-44 Soviet Medium Tank, Kit # 35193  
[http://www.track-link.com/forums/site\\_blogs/27686](http://www.track-link.com/forums/site_blogs/27686)

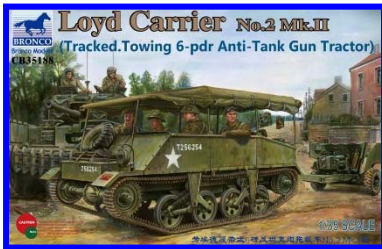

Bronco Loyd Carrier No. 2, Mk II (Tracked Towing 6-pdr Anti-Tank Gun Tractor), # CB35188, towing a Riich British Ordnance QF Mk. IV A-T Gun 6 Pdr, # 35042  
[http://www.track-link.com/forums/site\\_blogs/22053](http://www.track-link.com/forums/site_blogs/22053)

Jeff Nelson has 1 on Armorama.com:



Fine Molds Japan Ground Self-Defense Force Type 60 APC, FM40  
[http://www.armorama.com/modules.php?op=modload&name=SquawkBox&file=index&req=viewtopic&topic\\_id=213731&page=1#2056793](http://www.armorama.com/modules.php?op=modload&name=SquawkBox&file=index&req=viewtopic&topic_id=213731&page=1#2056793)

Additionally, Jeff did an In-Box-Review of this kit.  
<http://armorama.com/modules.php?op=modload&name=Reviews&file=index&req=showcontent&id=9272>

Keith Frappe also has 2 on Armorama.com:

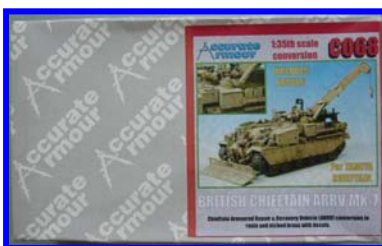

Chieftain Mk. 7 ARR (Tamiya + Accurate Armor Conversion)  
[http://www.armorama.com/modules.php?op=modload&name=SquawkBox&file=index&req=viewtopic&topic\\_id=241027](http://www.armorama.com/modules.php?op=modload&name=SquawkBox&file=index&req=viewtopic&topic_id=241027)



Up Armored Scimitar LEP with Bar Armor (AFV Club + Castoff Models Conversion)  
[http://armorama.com/modules.php?op=modload&name=SquawkBox&file=index&req=viewtopic&topic\\_id=212968](http://armorama.com/modules.php?op=modload&name=SquawkBox&file=index&req=viewtopic&topic_id=212968)

Bryan Moeller has one on Armorama.com:



Flakpanzer IV "Kugelblitz" (Cyber-Hobby's 1/35 scale "Orange Box" Series Kit #09 + Dragon's 1/35 Pz.Kpfw. IV Ausf. J Mid Production, Smart Kit #6556)

[http://www.armorama.com/modules.php?op=modload&name=SquawkBox&file=index&req=viewtopic&topic\\_id=250681#2120546](http://www.armorama.com/modules.php?op=modload&name=SquawkBox&file=index&req=viewtopic&topic_id=250681#2120546)

## Interesting Articles – NACM Tour 20 January 2018

On January 20, 2018, 22 of club members were able to visit the National Armor and Cavalry Museum (NACM) Restoration Center. What a true adventure. A special thanks goes to David Hobbs who was able to be our tour guide and informational source. Of Course, that doesn't count David Hobbs and Mike Powell (Easy 1 Productions) which bumps the total up to 24 for the whole group.



Phil Cavender  
AMPS # 3060, IPMS# 50085  
Editor, "The Wildcat"

## Interesting Articles – List of Modeling Techniques

*"The other day I was looking for one of Mike Roof's articles on weathering with oils, and in the process, realized that I should create a listing of his articles to make it easier to locate them. When I started searching through the Wildcat Newsletters to find the article, I found a treasure trove of his articles going all the way back to the original newsletter in 2010.*

*I created an Excel spreadsheet for the listing. I also included some articles by other modelers in the club that had topics I thought I might reference. I slightly changed some of the titles to make the articles easier to sort.*

*I can continue to add Mike's articles to the list as I find them, but at least I now have a good start on my project.*

*I thought I would share the list with you to see if you might want to include it in a future newsletter article. Hopefully it will save others time when they want to find one of Mike's articles."*

### **Mike Roof (& others) Modeling Articles**

<b><u>Topic</u></b>	<b><u>Location</u></b>
Scratchbuilding US-type Equipment Tie Downs (Footman Loops) (Mike Roof)	Wildcat Newsletter V1-N2, Aug-Sep 2010
Clear Parts for Armor Models (Mike Roof)	Wildcat Newsletter V2-N1, Jan-Feb 2011
Hex Nut Punch and Die Set - UMM (Mike Roof)	Wildcat Newsletter V2-N4, Apr-May 2011
Pre-shading and Scale Lighting (Mike Roof)	Wildcat Newsletter V4-N2, Feb 2013
"Art" of Scale Model-Building (Mike Roof)	Wildcat Newsletter V4-N6, Jun 2013
Finishing and Weathering - Part 1 "Philosophy" (Mike Roof)	Wildcat Newsletter V4-N8, Aug 2013
Finishing and Weathering - Part 2 "The Tools of the Trade" (Mike Roof)	Wildcat Newsletter V4-N9, Sep 2013
Vignette - What It Is and How to Judge It (Mike Roof)	Wildcat Newsletter V5-N1, Jan 2014
Airbrush Trouble Shooting - Understanding the Basics of How Your Air Brush Works (Mike Roof)	Wildcat Newsletter V5-N2, Feb 2014
Washes and "Tide Marks" (Mike Roof)	Wildcat Newsletter V5-N5, Jun 2014
Weathering - Artist Oil Paint Techniques (Mike Roof)	Wildcat Newsletter V5-N7, Aug 2014
Dioramas vs. Vignettes - Emotion and Drama (Mike Roof)	Wildcat Newsletter V5-N9, Oct 2014
Airbrushing with Tamiya Acrylic Paints (Mike Roof)	Wildcat Newsletter V7-N2, May 2016
Bases - Making a Simple Base (Phil Cavender)	Wildcat Newsletter V7-N3, Jun 2016
Attaching Small Parts (Jeff Nelson)	Wildcat Newsletter V7-N3, Jun 2016
Brush Recommendations (Mike Roof)	Wildcat Newsletter V7-N4, Jul 2016
Molding Seam Profiles (Basic) (Mike Roof)	Wildcat Newsletter V7-N4, Jul 2016

Basic Modeling: Mold Seam Profiles (Mike Roof & Jeff Nelson)	Website: Reference, GBs & Demos
Weathering Pigments and Pastels (Mike Roof)	Website: Reference, GBs & Demos
Photo Etch Building (Basic) (Mike Roof)	Website: Reference, GBs & Demos
Figure Painting, Part One (Mike Roof)	Website: Reference, GBs & Demos
Figure Painting, Part Two (Mike Roof)	Website: Reference, GBs & Demos
Figure Painting, Part Three (Mike Roof)	Website: Reference, GBs & Demos
Bases and Groundwork Seminar Slides (Mike Roof)	Website: Reference, GBs & Demos
Figure Painting with Oils Seminar (Mike Roof)	AMPS Website YouTube video
Inexpensive Display Plaques (Phil Cavender)	Wildcat Newsletter V7-N5, Aug 2016
Reusable Paint Palette (Phil Cavender)	Wildcat Newsletter V7-N6, Sep 2016
Pinning the Tracks (Need more detail)	Wildcat Newsletter V7-N8, Nov 2016
Weld Beads Using Squadron Green Putty (Mike Roof)	Wildcat Newsletter V7-N8, Nov 2016
Burnishing Metal Tracks (Mike Roof)	Wildcat Newsletter V7-N8, Nov 2016
Weld Beads - Club Meeting Demo (Mike Roof)	Wildcat Newsletter V7-N9, Dec 2016
Zimmerit Decals - Meng vs. DEF (Mike Roof)	Wildcat Newsletter V8-N1, Jan 2017
Drying Figures using Slow Cooker (Rebecca Hettmansperger)	Wildcat Newsletter V8-N1, Jan 2017
Link to Link Styrene Individual Tracks (Mike Roof)	Wildcat Newsletter V8-N2, Feb 2017
Making Springs (Mike Roof)	Wildcat Newsletter V8-N9, Sep 2017
Tow Cables - Finishing (Phil Cavender)	Wildcat Newsletter V8-N9, Sep 2017
Wood Grain (Herb Horvath)	Wildcat Newsletter V8-N9, Sep 2017
Making Tarps (Mike Roof)	Wildcat Newsletter V8-N10, Oct 2017
Working with Photo Etch, Part I (Mike Roof)	Boresight Magazine, Sep-Oct 2017
Painting Faces with Oils (Ralph Nardone)	Wildcat Newsletter V8-N11, Nov 2017

Weathering Tires with Pigments (Phil Cavender)

Wildcat Newsletter V8-N11, Nov 2017

US WWII Tank Antennas for Modelers (Mike Roof)

Wildcat Newsletter V9-N1, Jan 2018

Working with Photo Etch, Part II (Mike Roof)

Boresight Magazine, Nov-Dec 2017

US AFV Antennas used in WWII and the Korean War (Modeling) (Mike Roof)

Website: Reference, GBs & Demos

Working with Photo Etch, Part III (Mike Roof)

Boresight Magazine, Jan-Feb 2018

Carl Wethington  
AMPS #529  
Contributing Member  
AMPS Central SC "Wildcats"

## New Technique - Applying Zimmerit

The following article explains how to apply "zimmerit paste" using Milliput 2-part putty.

First try on a piece of scrap plastic to get the idea before you attack your model (examples with a Stug kit). With a little practice and patience you can easily achieve some very realistic results.

### CREATING BASIC ZIMMERIT

**Step 1 ~ Rolling out Milliput.** Using a round rolling pin and a generous amount of talcum powder, roll the Milliput out until it is as thin as paper. Keep turning it over and applying more talcum with a brush. Then with a brush wash the talcum off with water.





**Step 2 ~ Applying the Milliput.** First you should prepare the surface of the tank by sanding it lightly with course sandpaper. This gives the Milliput something to latch onto. Then lay the putty over the surface and then with a brush (or your finger) dipped in talcum powder you can press the putty down. Then with a sharp hobby knife trim the edges of excess putty.





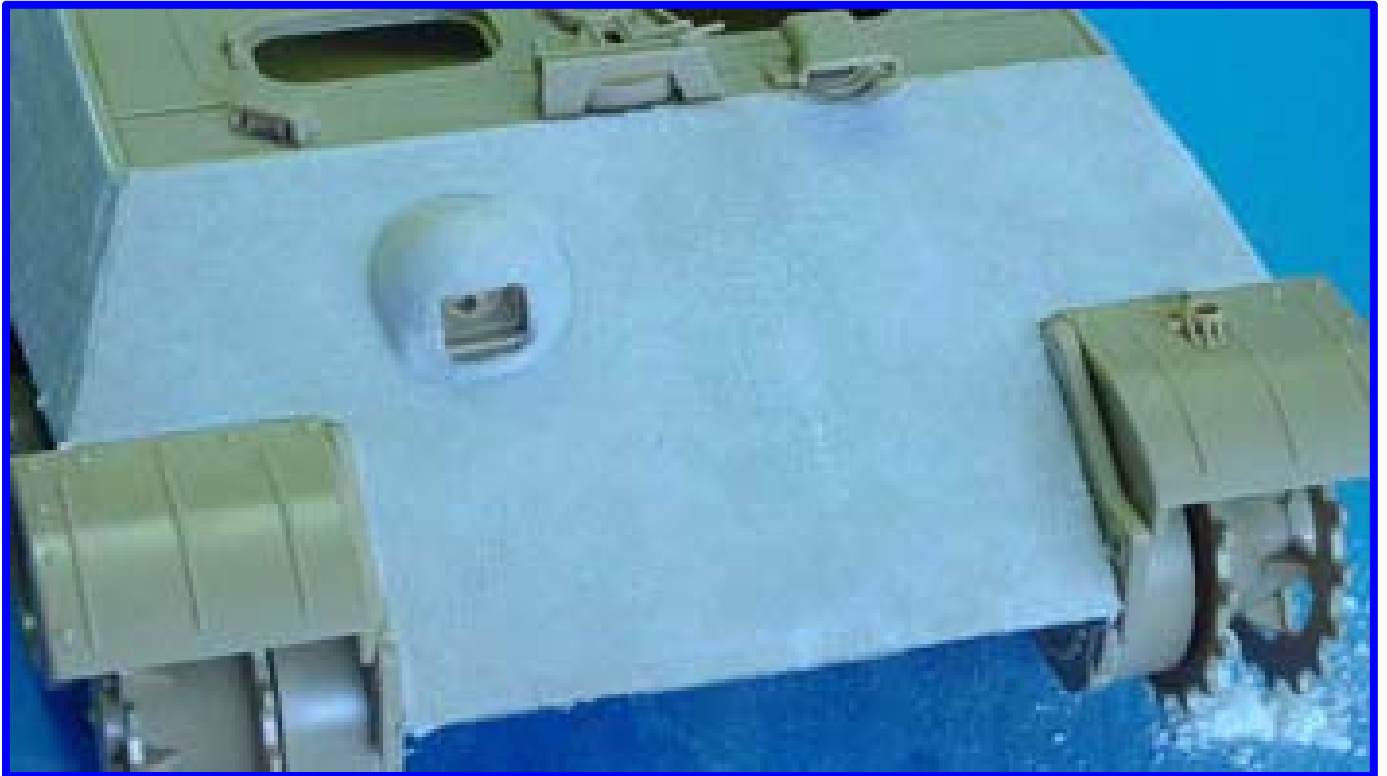

**Step 3 - Texturing the Putty.** You can use a screwdriver or make your own tool as I have out of plastic strip (4-5mm wide and 1mm thick with the end rounded off) and then insert it into the end of a hobby knife. You then start texturing the surface with the tool, using talcum powder to stop the putty sticking to the tool. Once it has dried overnight you can chip out areas to represent battle damage. The photos of the white zimmerit are not very clear, but check out the finished surface below.

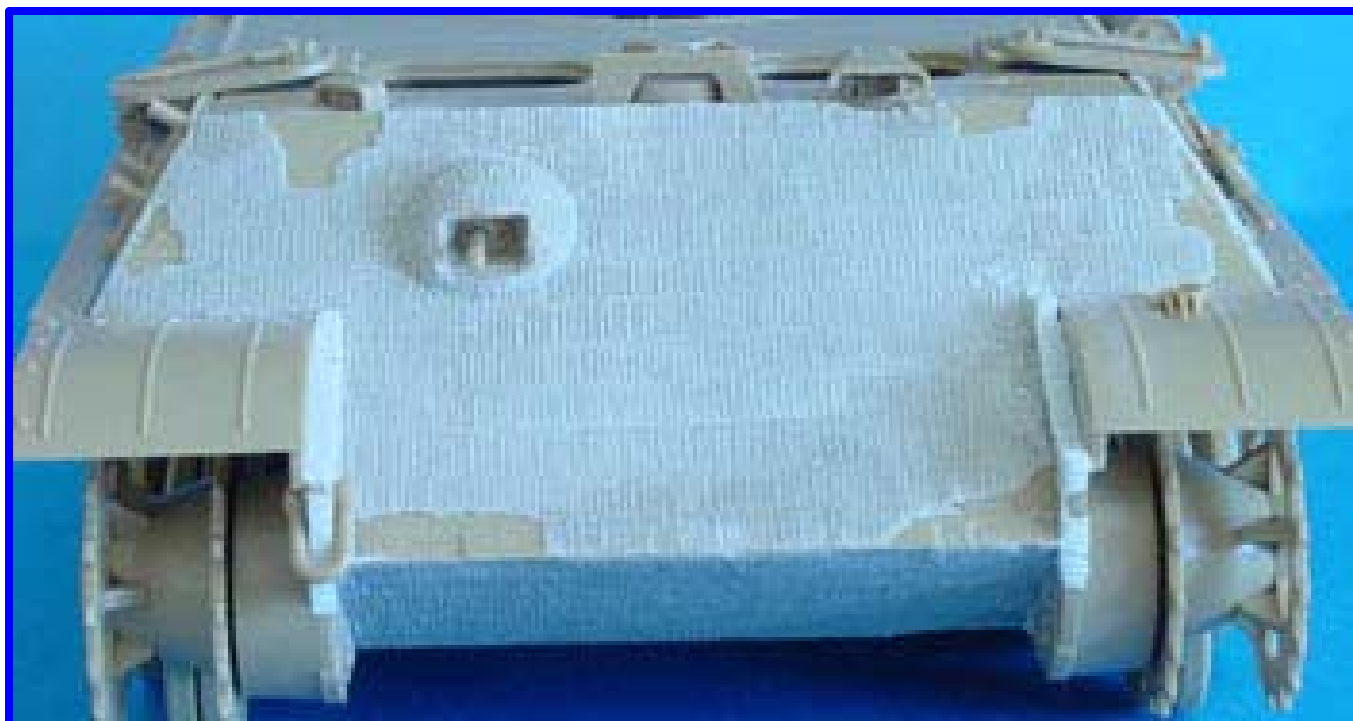

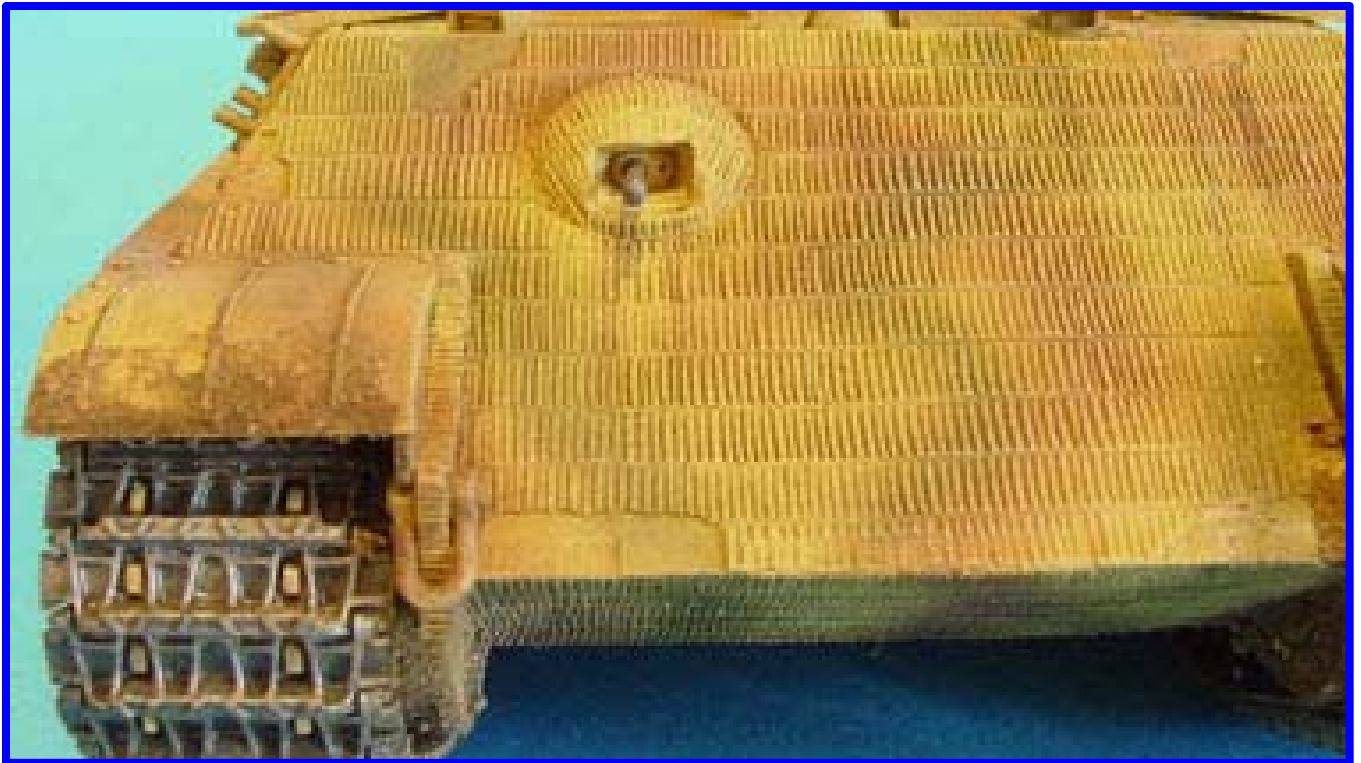

## WAFFLE PATTERN ZIMMERIT

**Step 1 ~ Rolling Out & Applying the Milliput.** Roll out a portion of Milliput into a thin layer. You can roughen the surface of the tank so the putty has better grip. Lay the putty over the surface and press down with finger or paint brush. Use talcum powder to stop the putty lifting off surface.



**Step 2 ~ Trimming & Applying the Pattern to the Milliput.** You can trim the edges before you start stamping the pattern. Then again apply some talc with a soft brush and then starting at the top corner stamp the pattern into the surface. On some areas you may need to use a small round object to get into tight spots. I use a large needle.

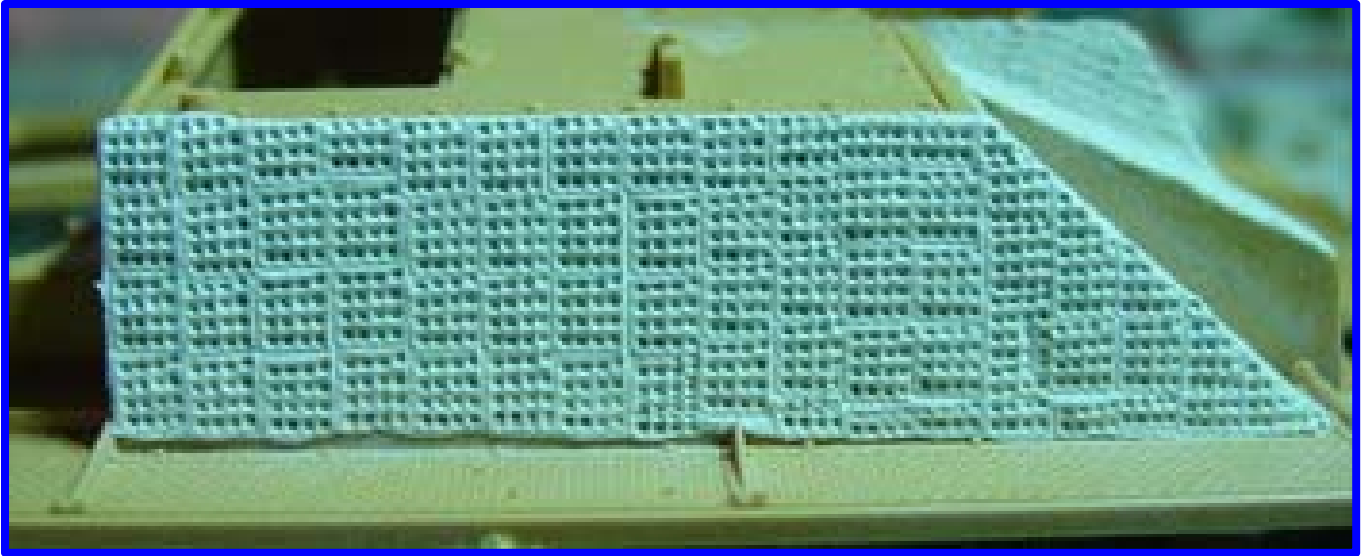

**Step 3 ~ Work on One Section of Milliput at a Time.** Do one area at a time so you don't accidentally touch the still soft putty and damage the pattern.

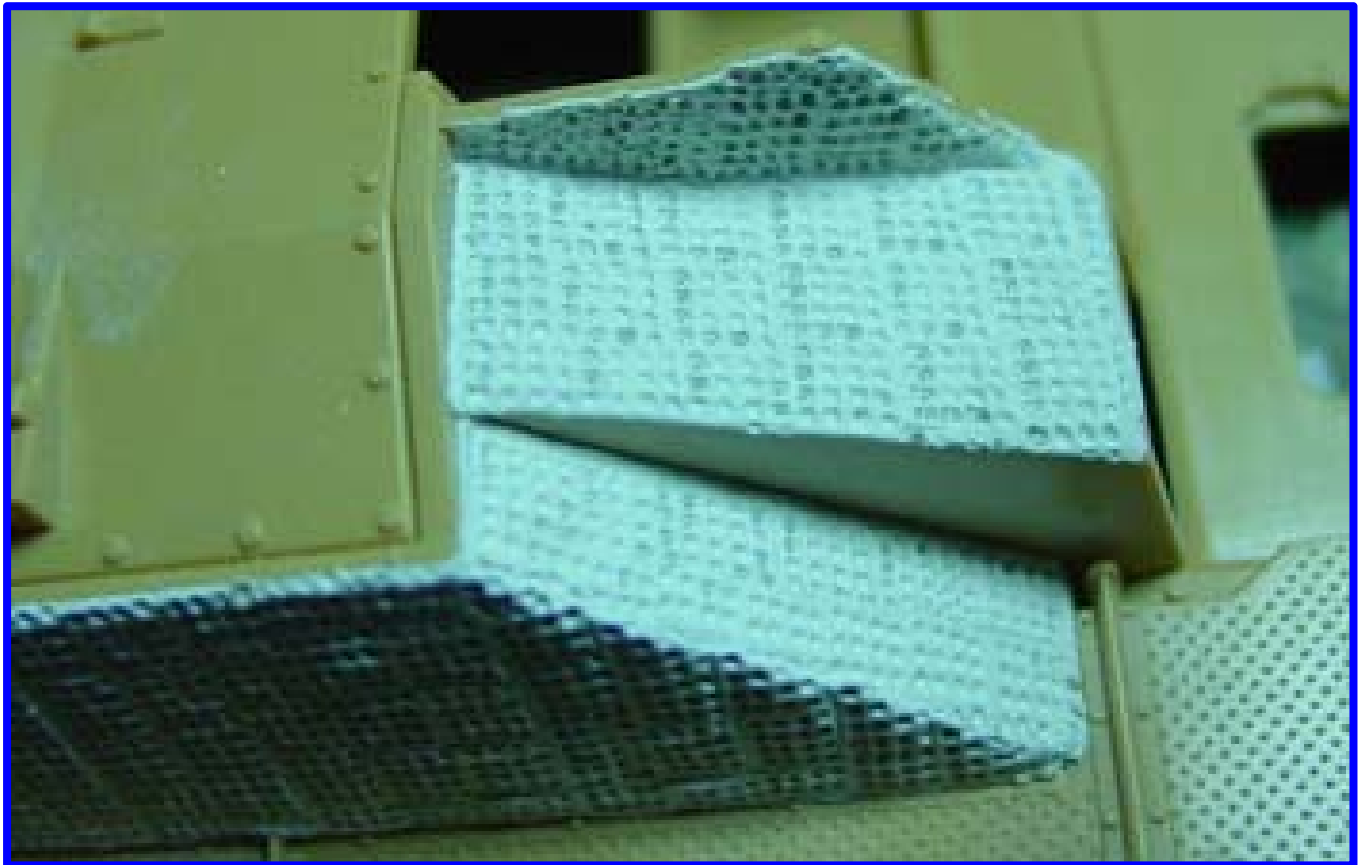

**Step 4 ~ The finished, painted Zimmerit.** You can simulate battle damage by breaking areas off by lifting with a hobby knife or small chips to simulate small arms fire damage.

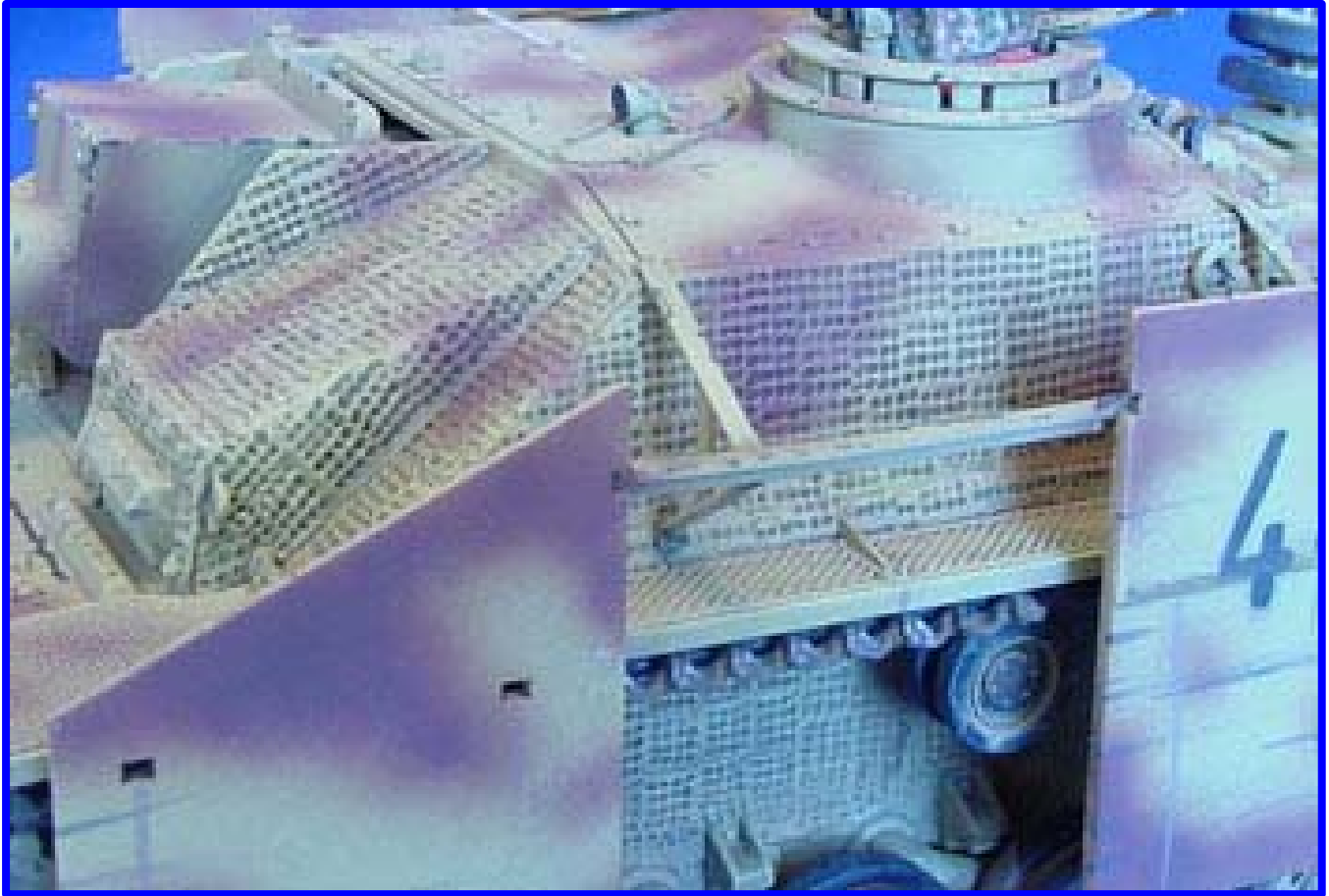

(From an Unknown source on Facebook)

## **New Techniques – Fading Panzer Grey, Vision Blocks, Link to Link Tracks**

### **Tips by Timmy**

#### **Fading Panzer Grey**

I read this tip in an English modeling mag a few years ago and it does work. The old way of fading Panzer Grey was to add white, but that makes it look "ashy" in my opinion. The mag said use pink not white, I know it sounds strange but it works, with both enamel and acrylic paints.

Paint the vehicle in your choice of Panzer Grey then get a pink and add a few drops into your paint or mixing cup and then spray them to where you need the fading. Just start off with a few drops and add more as needed. You can also do multiple fading applications by hitting it with your first fading mixture, then add more pink, spray that inside the first applications, and repeat as necessary. Remember you can always add more pink, if needed, but you will need to start over from scratch if you dork it up. Trust me on that one ;-)

I have done this with both Model Master enamel using their Panzer Grey and Pink Piping or with Tamiya's Panzer Grey and their Pink. At this time I have not tried it with Vallejo paints, but I'm sure it'll work. If you don't feel like mixing paint, you may use FS36118 Gunship Grey for the faded

Panzer Grey as straight Gunship Grey almost matches what you would come up with if you mixed pink with Panzer Grey.

I have done it both ways with successful results. You may also use straight Gunship Grey as your dry brushing color. In the photos, I used Model Master Panzer Grey/Pink on the Pz.Kpfw. IV, and I used Panzer Grey/Gunship Grey on the Kubelwagen.

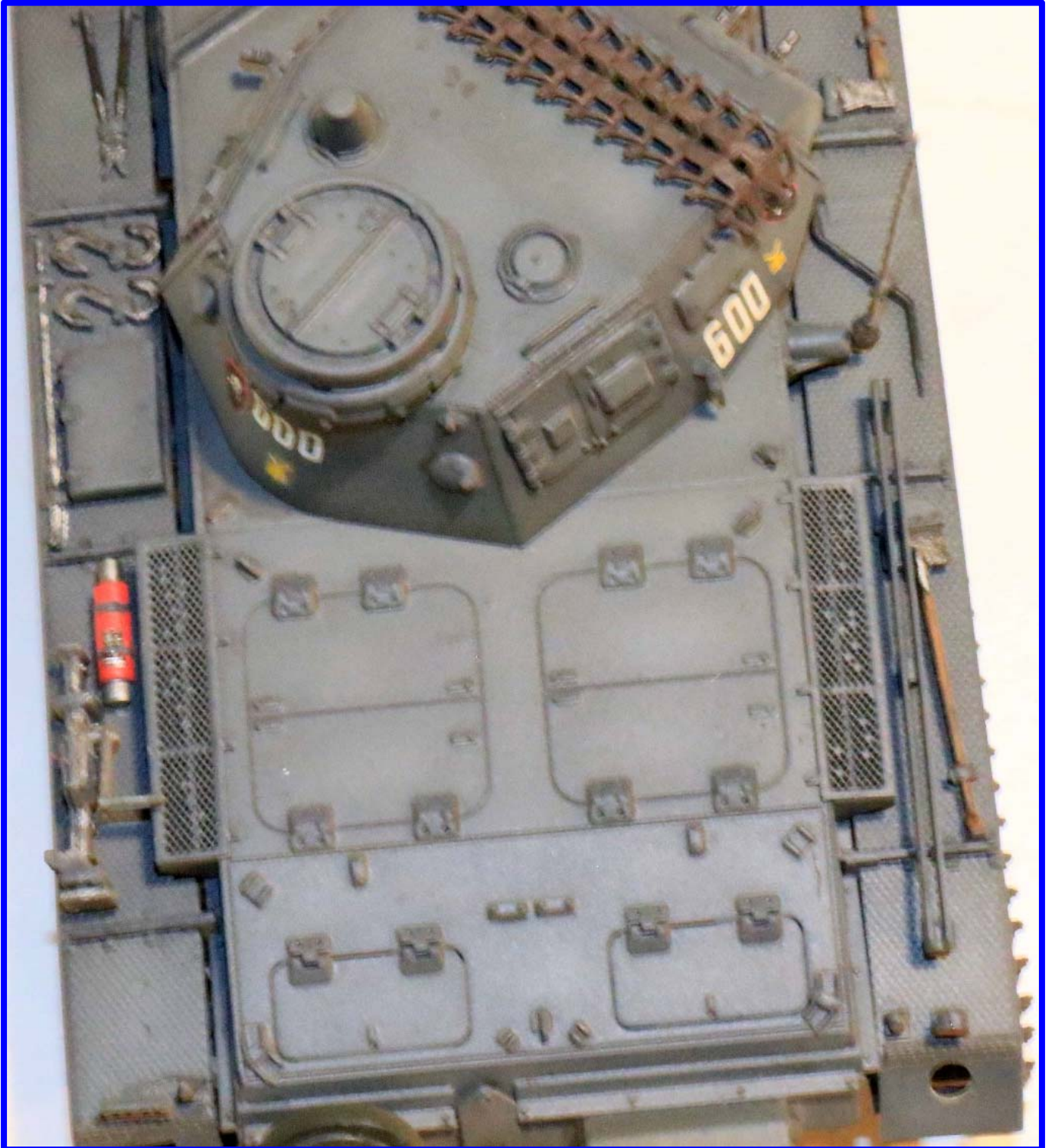



### Painting Modern Vision Blocks

I stumbled across this technique while working on my M577A2. I haven't tried this with solid vision blocks but I'm sure it'll work out. Take your clear vision block and apply Future Floor Wax to it and let dry/cure, about 3-4 days (I like to error on the side of caution). Then on the back side of the vision block, paint it with Tamiya X-27 Clear Red, once dry then add either Tamiya X-12 Gold or X-31 Titan Gold, then again let it dry/cure. This will provide a nice representation of the anti-laser coating found on modern vision blocks. Finally add a thin wash version of the Clear Red to the outside and you're finished. Please note that in the photo, I have not added the final Clear Red wash over the front; you may use Tamiya X-20 Thinner to thin the Clear Red.

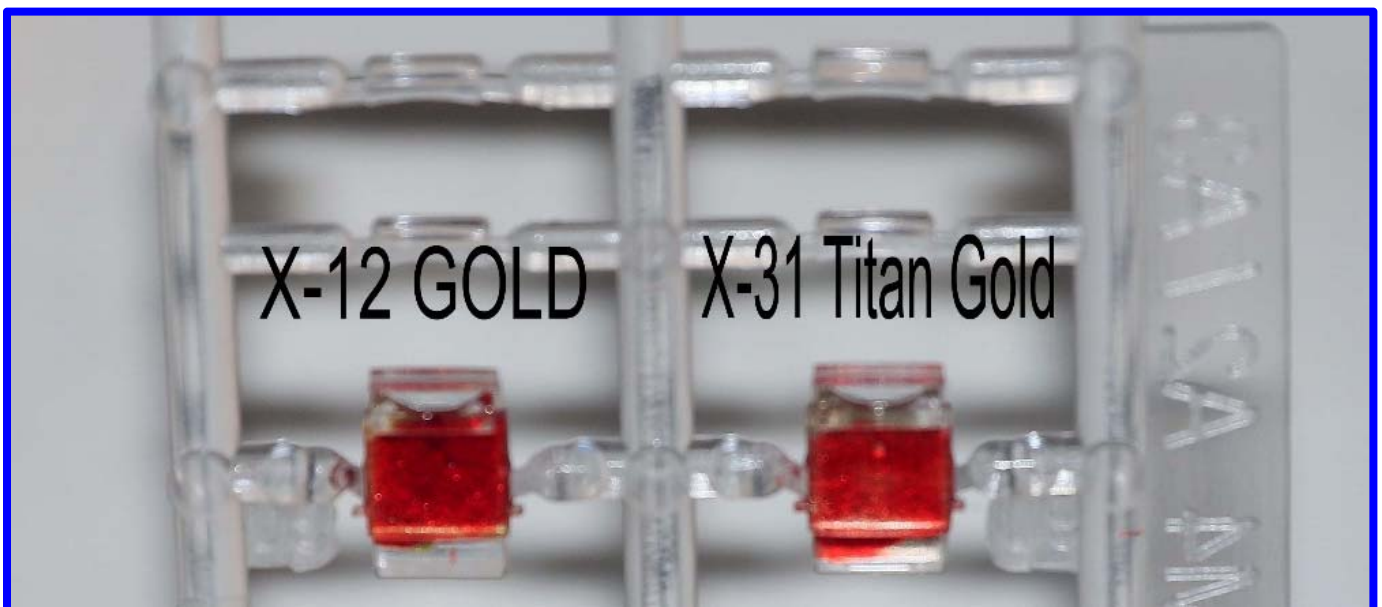

## **Building link-to-link tracks**

There is a company in Plymouth, IN, called Hobbytrax (<http://hobbytrax.net/>), and they make great jigs for every type of tracks, link-to-link, link-n-length or rubber band. The tools are machined aluminum blocks to fit a certain vehicle providing accurate track sag and tension, making track building tons easier than the old fashion way of trial and error using the kit itself, and reduces the possibility of breaking stuff off of the vehicle.

True, the jigs do cost a bit, but if reasonable if you are going to do a lot of the same type vehicle, i.e. Sherman or T-62s. Also please note that they have supported our shows in the past by sending raffle donations.

In the photo, you can see their two part jig for the AAV7A1 (LVTP7) with one run completed and the other in work. I have written on each block to show what vehicle it fits and which way is forward. Those items are etched in the aluminum but for quicker and easier identification, I've decided to do it this way. This jig is a two part jib that is held together by nuts & bolts, so apply the track links (pay attention to which way they should go, glue them together and let the dry/cure, remove the securing hardware and you're ready to paint them, etc. I always let the tracks cure on the jig for at least 3 days to be on the safe side. The M4 Sherman jig is one piece, so you will need to pre-plan an open link in order to get the jig out. Again, I know from experience as I failed to do this on my M4A3 ARV; stoopid me.

To attach the tracks to your vehicle, temp install your drive sprocket and idler wheel on the tracks then place on the kit, then add your road wheels. Be careful to not break your tracks, but this is the way to do it. I have thought of trying to do the tracks and wheels as a single assembly, but I haven't had the nerve to try it yet.



## **Vallejo Paints**

I was researching Vallejo paints but do not have a paint chart for their line of Model Air paints. So after I quick search on the Web, I found this on their web site ([http://www.acrylicosvallejo.com/en\\_US/downloads](http://www.acrylicosvallejo.com/en_US/downloads)), scroll on down until you see "Model Paints", and there you can download all of their printed material showing paint chips, etc. If you download their catalog, you will find, from pages 114-121, a full listing of the Model Air paints along with applications. So if you want to know what Vallejo paint to use on the Caunter Scheme, it's there,



or the various MERDEC schemes, those are listed as well. For those of you, like me, that also build aircraft, they provide the same lists for various Russian modern aircraft USAF Aggressor schemes (very cool as my first unit I was in was the 64th FWS Aggressors at Nellis). I have saved some of their various brochures, but it would be nice to get printed versions of them. I'll ask Brandon at HobbyTown if he can get some for us.

Hopefully some of these tips will be of benefit with you all.

Tim Darrah  
AMPS # 2545  
Contributing Member  
AMPS Central SC "Wildcats"

## The USA Historical AFV Register

Mike Roof has provided us with a great link he found that may be of interest to all.

"For those who are interested in preserved AFVs or photographing them for research, here's a link to the latest issue of the AFV Register Organization's "The USA Historical AFV Register."

The register is broken down by state and city, with the AFVs listed along with their exact locations (to include GPS lat/long coordinates). This is a good list to keep saved on your computer.

If you travel around you can plan accordingly (look up your travel destination or itinerary stops to see what interesting AFVs might be there), and if you need reference material on a particular vehicle, you can often contact one of your "virtual" friends online who lives near an exhibit to take some pictures for you".

## The USA Historical AFV Register

*Armored Fighting Vehicles Preserved  
in the United States of America*

**V4.0**

**March 2016**

**Michel van Loon  
Neil Baumgardner**

**For the AFV Association**



<http://afvregister.org/Downloads/The%20USA%20Historical%20AFV%20register%204.0.pdf>

**Support Our Local Vendors**



10120 Two Notch Road, Suite 5  
 Columbia, SC 29223  
 (803) 736-0959  
<https://www.hobbytown.com/columbia-e-sc/l57>  
 HobbytownColumbiaSC@gmail.com

(\* ) - New Store Hours, (#) – Model Build Days EVERY Saturday starting at noon.

*Sunday	12-5
Monday	11-7
*Tuesday	Closed
Wednesday	11-7
*Thursday	11-7
*Friday	11-8
Saturday	10-8 (#)

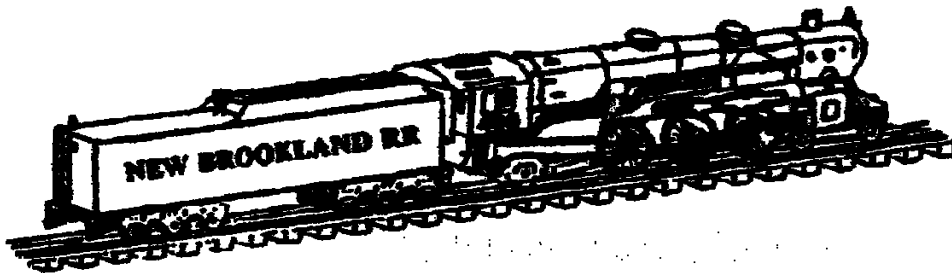

405 State Street  
 West Columbia, SC 29169  
 (803) 791-3958  
 Mon – Sat, 10am to 6pm



5633 Broad Street  
 Sumter, SC 29154  
 (803) 983-5084  
 Mon – Sun, 2pm to 7pm



## Classified Ads

All submissions for entry into the Classified Ads section should be submitted to the editor two (2) weeks prior to the monthly AMPS meeting. Next submission deadline will be August 30, 2017.

**Wanted:** I am looking for the Eduard (35 233) 1/35 photoetch M110A2 SPH update set for the Italeri M110/M1102, and M107 kits. As with the Hobby Fan resin Kit, I kept waiting to buy one until it also was gone! -- Are you picking up a recurring theme here? **Contact Carl Wethington.**

**Wanted:** I am looking for the Hobby Fan (HF001) 1/35 resin M110A2 SPH update set for the Italeri M110/M1102, and M107 kits. As you can tell from the item number it was the first resin detailing kit make by Hobby Fan. It was an excellent set that replaced much of the traditional Italeri soft detail, and included an outstanding loader / rammer section. I kept waiting to buy one -- until, well, it was gone! If you come across one, I would be glad to "rent" the set to make resin masters for my M110 and M107 kits. Thanks for any leads you can offer!  
**Contact Carl Wethington.**

**For Sale:** The following kits are for sale. **Contact Trevor Edwards.**

1. M48A3 Mod B (Dragon #3544)...\$25.00
2. Object 693 (Panda #PH35024)...\$25.00
3. Landwasserschlepper (Hobby Boss #82430)...\$15.00
4. M4A3E8 (DML #9009)...\$20.00
5. M5A1 (AFV Club #AF35105)...\$20.00 **SOLD**
6. Staghound Mk 1 Late Version (Italeri #6459), still in shrink wrap...\$20.00

### "The Day Room"

*In the US military, most company-level units have a "day room" in the barracks where the troops hang-out, relax, and BS. When you want to learn the latest in "rumor control," you swing by the day room and chat-up the Joes and Janes hanging out there. They might not always get it right, but they're always willing to tell ya just what they think! So, welcome to "the Day Room..."*

Don't forget about the upcoming events to show our support.

Also don't forget to send me your favorite techniques you've learned through the years. We all would benefit. I'll include them in our next newsletter.

Finally, if you aren't a member of AMPS, now is the time to join. **Join AMPS Now!**

<http://amps-armor.org/>

Happy modeling,

*Phil Cavender*

Editor, "The Wildcat", AMPS Central SC "Wildcats"