

# A Comparative Study of Various Forecasting Methods For Solar Photovoltaic System Power Output

Rahul Saraswat<sup>1</sup> Deepak Jhanwar<sup>2</sup> Rahul Agarwal<sup>3</sup> Saurabh Kumar<sup>4</sup>

<sup>1,2</sup>Department of Electronics & Communication Engineering, Government Engineering College, Ajmer, Rajasthan INDIA

<sup>3,4</sup> Department of Electronics & Communication Engineering, Anand Engineering College ,Agra

This paper presents the development and comparison of various forecasting models for solar photovoltaic system power output for one day. The actual data collected has been used for solar power forecasting using data logger. The forecasting model is developed using Artificial Neural Network (ANN), Neuro-Fuzzy and GNN . The data of past three days are used for training the ANN forecasting model and the next day solar power is predicted.

This paper basically shows the comparison of prediction efficiencies of these forecasting models developed

**Keywords:** Solar Photovoltaic, Prediction Efficiency, Electrical Efficiency, ANN, Neuro-Fuzzy, GNN.

## 1. INTRODUCTION

Solar cells or simply Photovoltaic (PV) cells are cells that convert energy from sun into useful electric energy using semi conductor PN junction devices. A PV cell is the fundamental unit which generates voltage in that varies range of 0.5 to 0.8 volts depending on cell manufacturing technology used. This much generation cannot of much useful for commercial applications but when we look physically in a PV system is the module that is available commercially; which can be further reconnected to get the desired energy. [1]

The PV system is physically connected to form the module that is available commercially; which can be further reconnected to get the desired energy. When experiments are made with solar cells in order to analyze the behavior of it, it comes out as a time consuming & costly work. This difficulty is solved by various simulation techniques that can be very useful in order to simulate the performance of a solar PV cells under various operating techniques. of a building with respect to the Sun. The separate PV Systems are very much useful for solar street lighting, home lighting.

### 1.1 Diagnosis of Solar Data

The acquisition of solar power output of Panel has been done through a data logger which is prepared at DEI, Agra. The power output has been analyzed for four consecutive days and the pattern is shown in the figure given below

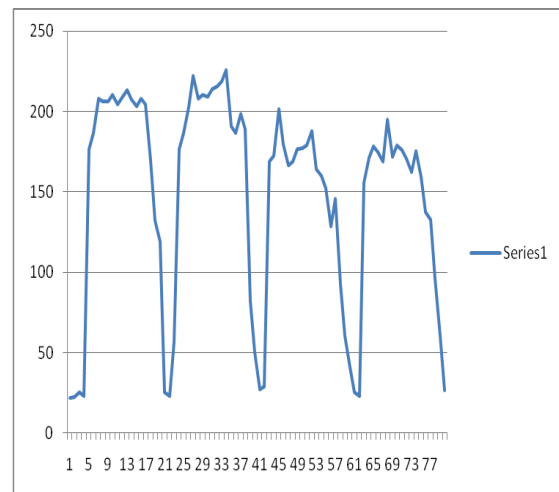

Power output of Solar Panel for four days

Three days data has been taken for the training and analysis of various forecasting methods i.e ANN & Neuro-Fuzzy model. The forecasted output for the fourth day has been compared with the real time data of fourth day of this solar panel.

## 2. Forecasting Model using ANN

In this paper the next step is to develop a model using artificial neural network (ANN) to predict the power generated by Solar Photovoltaic system. To develop this model a back propagation (BPA) network structure is used. In machine learning ANNs are known as the computational models which are inspired by biological neural networks (central nervous systems) and can be used to predict various function in which there can be a large non linearity.

Artificial neural networks are basically the interconnection of neurons which can be used for the computation of the predicted values from inputs and are generally capable of machine learning as well as pattern recognition thanks to their adaptive nature.

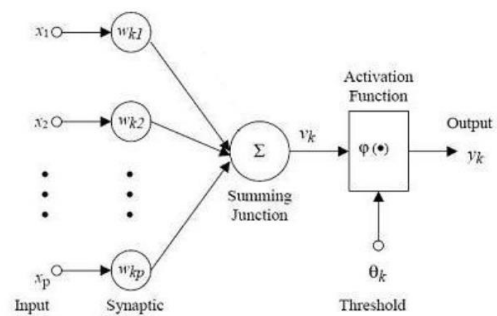

Fig.2.1 Model of ANN

Power generation from the solar panel plays a vital role because this is the power which is used in the absence of electricity provided by distributor or in the remote areas that are far away from the electricity

So we can predict the power using the power data for three days and to predict the power for the next day.

**2.1 Approach**

The inputs were fed into our Artificial Neural Network (ANN) and after sufficient training were used to predict the power for the next day.

The inputs given are:

1. Half Hourly power for the full day.
2. The inputs are given as P(t), P(t+1), P(t+2) and output P(t+3) is predicted.
3. Number of Days of the week.

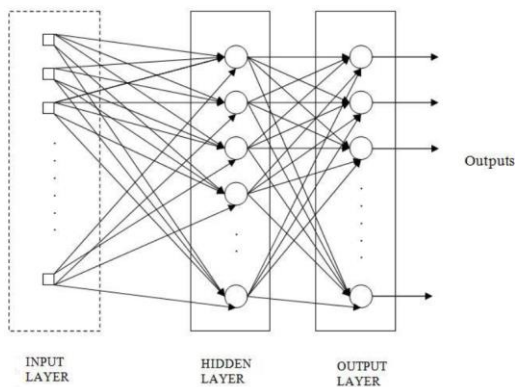

Fig.2.2 Network Architecture of ANN Model

**2.2 Method Used**

In this Back propagation Algorithm is used which is based on gradient-descent rule and this is also known as Delta Learning rule.

Delta learning rule is basically used in machine learning .In this rule there is update in the weights of the inputs which are given to the neurons in order to reduce the error of the

output.

$$\delta C_{ji} = \beta (T_j - A_j) g'(h_j) I_i \dots \dots \dots (1)$$

- where
- $\beta$  is Learning Rate
- $g(x)$  is activation function
- $T_j$  is target output
- $h_j$  is weighted sum of neuron inputs
- $A_j$ =actual output
- $I_j$  is input to neurons

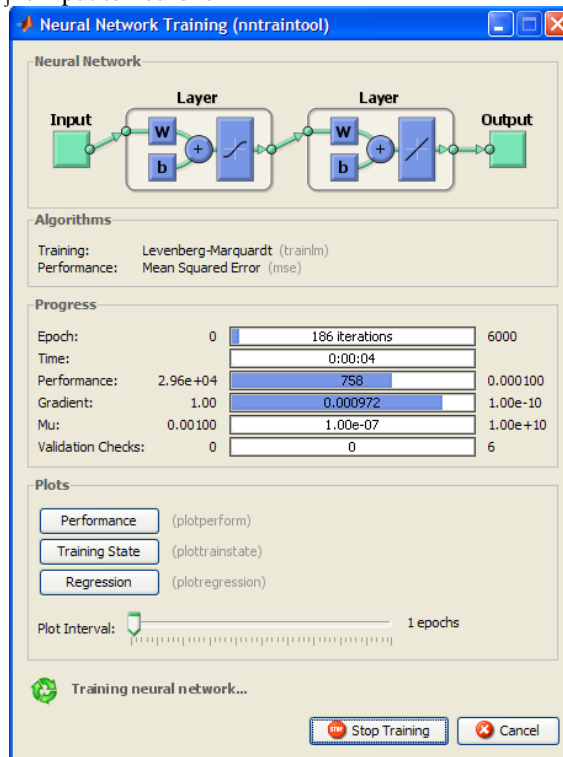

Fig 2.3 Execution of ANN model

The epochs are set using the following command `net.trainparam.epochs=6000` to get the error up to .0001. The resulting training data curves are as follows

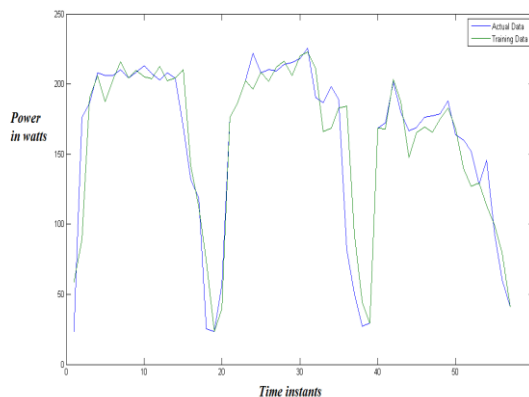

Fig 2.4 Training data output of ANN

The forecasted output is as follows

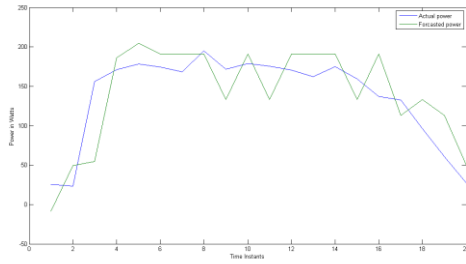
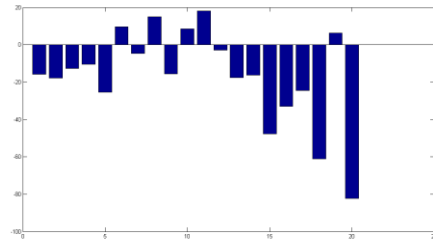
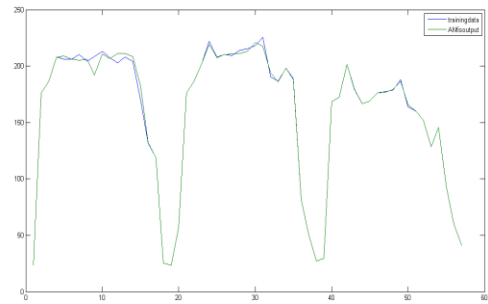

Fig 2.5 Predicted output for 4<sup>th</sup> day

The error plot for ANN is as follows



ANN Error Plot



Training Data curve using NFS

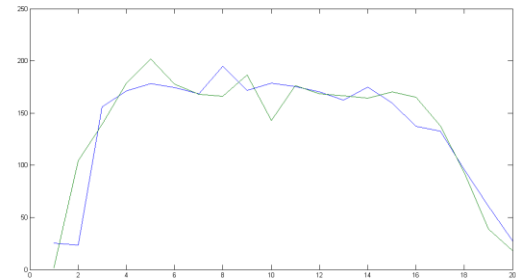

Forecasted output using NFS

The error curves are as follows

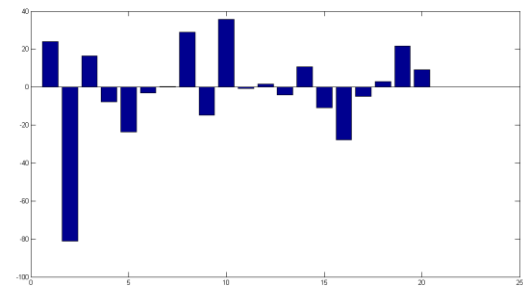

Error curves in NFS

### 3. Forecasting Model using Neuro- Fuzzy Model

Neuro-Fuzzy model can be thought as a combination of ANN and Fuzzy logic in which a large non-linearity of input can be handled.

In this model two very important intelligence techniques are combined

- 1) The human like reasoning style using Fuzzy Logic.
- 2) The machine learning structure of ANN.

A fuzzy inference system can be used to mimic the human expertise by using a rule base and storing the important content in the it. Then it performs the reasoning function to forecast the output.

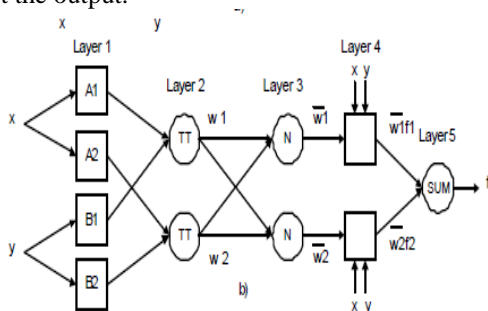

Fig 3.1 Network Architecture of Neuro-Fuzzy System

#### 3.1 Approach

In this forecasting model a FIS file has been made and given a name NFmodel. This file has been imported to MATLAB. This FIS file is read using the following command `fis=readfis('NFmodel')`

Now using the rulebase the inference calculations are made using the following command

`a=evalfis(ptestin,fis)`

Then the plots for training and forecasting are as follows

This model development uses the following steps:-

- 1) Input & output Variable selection
- 2) Range normalization of the variables
- 3) The number of fuzzy sets for every variable
- 4) Membership function for each set
- 5) Definition of each number of rules
- 6) Selection of intersection models
- 7) Composition rule selection

The combined forecasting curve for these methods is as shown below

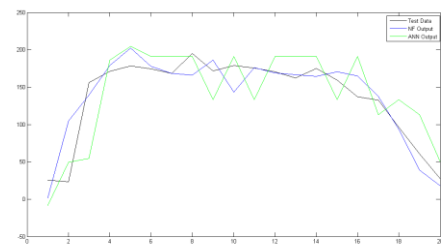

Combined forecasted results for ANN & NFS

The RMS errors for both of these forecasting models are as given below

S.No	Name of Forecasting Model	RMS error
1	ANN	1.86
2	Neuro-Fuzzy model	1.24

#### 4. CONCLUSION

From the above analysis we can conclude that the two forecasting models for the solar power output forecasting are presented in this paper and they seem to be quite successful for the forecasting of power of solar panel with satisfactory accuracy. The 'tansig' 'purelin' functions are used in the Feed forward neural network to train effective number of neurons in the hidden layer and an hybrid learning algorithm has been applied to the adaptive neuro-fuzzy inference system that uses the back propagation gradient descent method for training FIS membership function parameters. The graphical results show that the prediction accuracies of these two models are different, as far as the correlation coefficient is concerned, and the adaptive neuro-fuzzy inference system is more accurate because more parameters are determined also the error is less in NFS.

#### REFERENCES

- [1] Chaturvedi, D.K. 'Modeling and Simulation of Systems using Matlab/Simulink', CRC Press, New York, 2010.
- [2] J.-S. R. Jang, C.-T. Sun and E. Mizutani, "Neuro-Fuzzy and Soft Computing: A Computational Approach to Learning and Machine Intelligence," Prentice-Hall, Upper Saddle River, 1997.
- [3] G. J. Klir and B. Yuan, "Fuzzy Sets and Fuzzy Logic: Theory and Applications," Prentice-Hall International, Inc., Englewood Cliffs, 1995.
- [4] H. Demuth, M. Beale and M. Hagan, "Neural Network Toolbox User's Guide," The MathWorks Inc., Natick, 2010.
- [5] J.-S. R. Jang, "ANFIS: Adaptive-Neuro-Based Fuzzy Inference System," *IEEE Transactions on Systems, Man and Cybernetics*, Vol. 23, No. 3, 1993, pp. 665-685.
- [6] B. Park, "Hybrid Neuro-Fuzzy Application in Short-Term Freeway Traffic Volume Forecasting," *Transportation Research Record*, Vol. 1802, 2002, pp. 190-196
- [7] Jiin-Po Yeh, Yu-Chen Chang " Comparison between Neural Network and Adaptive Neuro-Fuzzy Inference System for Forecasting Chaotic Traffic Volumes" *Journal of Intelligent Learning Systems and Applications*, 2012, 4, 247-254
- [8] W. Mendenhall, R. L. Scheaffer and D. D. Wackerly, "Mathematical Statistics with Applications," 3rd Edition, Duxbury Press, Boston
- [9] M. Sugeno, "Industrial Applications of Fuzzy Control," Elsevier Science, Amsterdam, 1985