

Master Valve USA

G Series Trunnion Ball Valve



Tough Ball Valve for Toughest Flow



www.MasterValveUSA.com



*Zero Leakage Ball Valves for Chemical, Refining,
Pipeline and Exploration Applications*



Innovative Engineering Design

Based on years of valve application experience and material breakthrough, Master Valve's innovative ball valve design deliver following features to our customers:

- Low stem torques, typically 20% lower than the norm, which drives your automation costs lower
- Better performance in sealing and leak protection due to new materials used
- Lighter weight resulting in better protection to your pipes and flanges

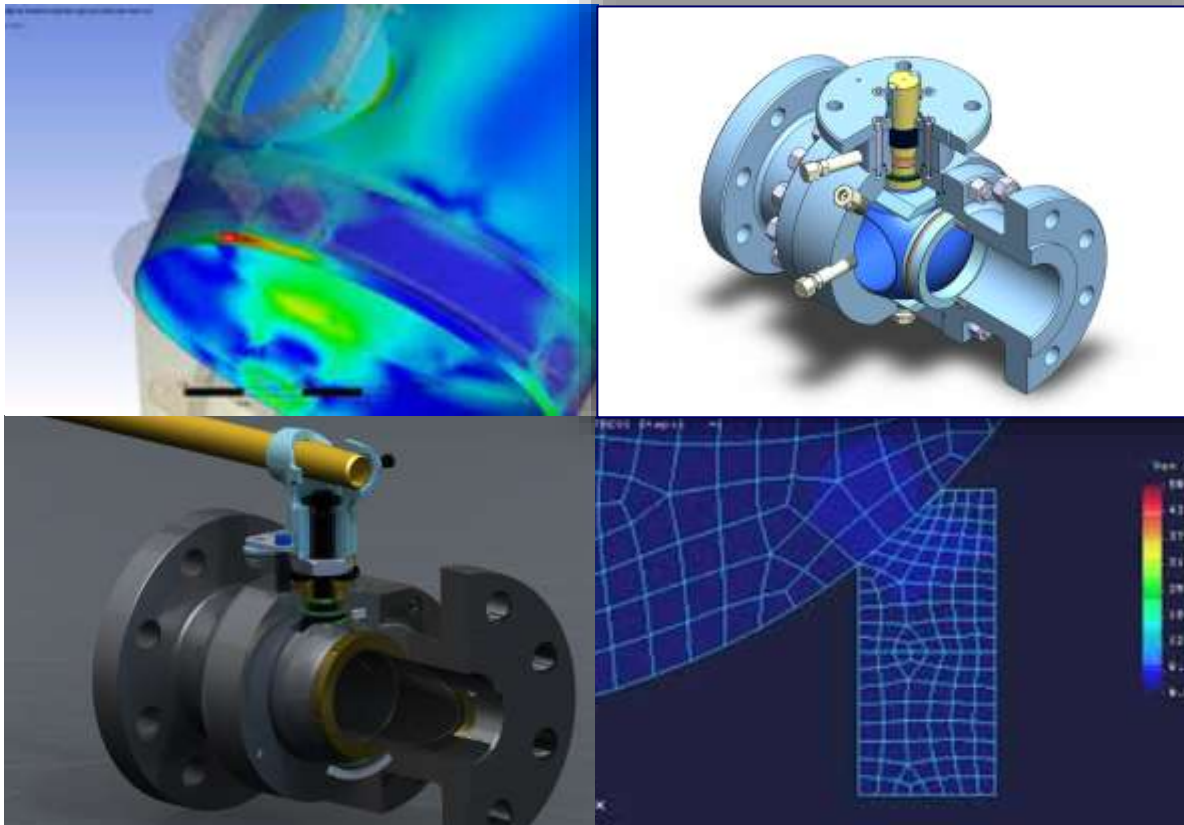

Tough Ball Valve for Toughest Flow

Manufacturing Capabilities

MasterValve® has its own forging facility and heat treatment workshop. We can strictly control forging process, welding process, heat treatment, assembly, final testing, cleaning and painting.



Tough Ball Valve for Toughest Flow

Tough Ball Valve for Toughest Flow



All MasterValve® quality products are tested to meet the most stringent standards of Qualifying Authorities around the world. Advanced engineering and Quality Management System assure that our valve products continue to exceed your expectations for performance. Good quality comes from uncompromised disciplines.

Quality Control



Inventory for Short Lead-time

Inventory is a critical piece of our business model to make customers life easier. Master Valve and associated companies keep inventory from forging material, work-in-progress to finished valves. In today's environment, our customers need our inventory to cut their project delivery short and archive high Return On Investment (ROI).



Tough Ball Valve for Toughest Flow



Table of Contents

MasterValve® G1 and G2 Series Forged Ball Valves

Applications of G1 & G2 Series Forged Ball Valves	8
Design Standards & Design Features	9
Design Features on Request	14
How To Order	16
Material Options	18
Pressure & Temperature Ratings	19
G1 Series Standard Design General Assembly	20
G1 & G2 Series Dimensional Data	21

Due to upgrades in industry standards, material innovations, and Master Valve® constant commitment to product advancement, data presented in this brochure is subject to change. Please contact your Master Valve Sales person for updated and/or current drawings and material compliance. This information is available on our website at www.MasterValveUSA.com

Tough Ball Valve for Toughest Flow

Applications of G1 & G2 Series Forged Ball Valves

Master Valve® manufactures some of the most dependable forged steel ball valves in the industry. Master Valve® offers G Series forged ball valves and is a complete solution for your flow control applications. Master Valve® manufactures a complete range of **API 6D** floating and trunnion mounted ball valves in a size range of 2" to 56" in pressure ratings of up to class 2500. Master Valve manufactures a complete range of **API 6A** trunnion mounted ball valves in a size range of 2" to 30" in pressure ratings of up to API 10000.

G1 & G2 Series valves are designed, manufactured, and tested in accordance with respective API, ASME, and ANSI standards, for instance, API 6D, API 6A, API Q1, API-607, ASME B16.34, ASME B16.5, ASME B16.47, ASME B16.10, ASME B16.25, MR-01-75, TA-Luft/ISO 15848 et al. In the standard versions, **G1 & G2** series ball valves are specified for transmission pipeline, pumping stations, compressor stations, gas processing plants, rejection units, offshore platforms, and chemical processing.



G1 Series Valve

3-Piece side entry forged trunnion mounted ball valve

G2 Series Valve

2-Piece side entry forged trunnion mounted ball valve

Tough Ball Valve for Toughest Flow

G1 and G2 Series Design Standards and Design Features

Design Standards

American Petroleum Institute

- API 6D -- Specifications for pipeline valves
- API 607--- Fire test for soft-seated ball valves
- API 6FA ---Fire test for valves
- API Q1 --- Specifications for quality programs
- API 6A ----Specifications for Wellhead and Christmas tree equipment

Manufacturers Standardization Society

- MSS SP-25 --- Standard marking system for valves
- MSS SP-55 --- Quality Standard for Steel Casting

American National Standard

- ASME/ANSI B16.10 --- Face-to-face and end-to-end dimensions on ferrous valves
- ASME/ANSI B16.5 --- Steel pipe flanges and flanged fittings
- ASME/ANSI B16.47 --- Large Diameter Steel Flanges
- ASME/ANSI B16.25 --- Buttwelding ends
- ASME/ANSI B16.34 --- Steel valves-flanged and butt-weld end
- ASME/ANSI B31.1 --- Chemical plant and petroleum refinery piping

ISO Standards

- ISO 15848-1 Industrial Valves – Measurement, Test and Qualification procedures for fugitive emissions
- ISO 5211 Industrial valves — Part-turn actuator attachment for actuator mounting pad

National Association of Corrosion Engineers

- NACE MR-01-75 --- Sulfide stress cracking materials for oilfield equipment

Standard Features

- Double block and bleed
- Spring loaded floating seat design
- Cavity pressure self-relieving
- Multiple seal for protection against external leakage
- Stem separated from the ball and anti-blowout design
- Triple seal for protection against stem leakage / Meet TA LUFT & ISO 15848
- Stainless steel trim parts for 4" and smaller / ENP plating for trim parts for 6" and up
- Antistatic device;
- Emergency stem and seats sealant injection fitting
- Fire safe to API 607 & API 6FA
- NACE compliance and fully comply with MR-0175

Features upon Request

- Double piston effect design (DIB-1 type and DIB-2 type)
- Live-loaded stem packing feature
- Lip seal design
- Cryogenic service design (-196°C or -320°F)
- Extended stem design for buried service

G1 and G2 Series Standard Design Features (cont')

Manufacturing range of API 6D G series is shown in the table below. Other sizes and special classes are also available against specific request.

Size		ASME CLASS					
NPS	DN	150	300	600	900	1500	2500
2	50	G1; G2	G1; G2	G1; G2	G1; G2	G1	G1
3	80	G1; G2	G1; G2	G1; G2	G1; G2	G1	G1
4	100	G1; G2	G1; G2	G1; G2	G1; G2	G1	G1
6	150	G1; G2	G1; G2	G1; G2	G1	G1	G1
8	200	G1; G2	G1; G2	G1; G2	G1	G1	G1
10	250	G1; G2	G1; G2	G1; G2	G1	G1	G1
12	300	G1; G2	G1; G2	G1; G2	G1	G1	G1
14	350	G1	G1	G1	G1	G1	*
16	400	G1	G1	G1	G1	G1	*
18	450	G1	G1	G1	G1	G1	*
20	500	G1	G1	G1	G1	G1	*
24	600	G1	G1	G1	G1	G1	*
26	650	G1	G1	G1	G1	G1	
28	700	G1	G1	G1	G1	G1	
30	750	G1	G1	G1	G1	G1	
32	800	G1	G1	G1	G1	G1	
34	850	G1	G1	G1	G1	G1	
36	900	G1	G1	G1	G1	G1	
40	1000	G1	G1	G1	G1		
42	1050	G1	G1	G1	G1		
46	1150	G1	G1	G1	G1		
48	1200	G1	G1	G1	G1		
56	1400	G1	G1	G1			

* --- Available upon special request

Tough Ball Valve for Toughest Flow



Standard Design Features—G Series Forged Ball Valve

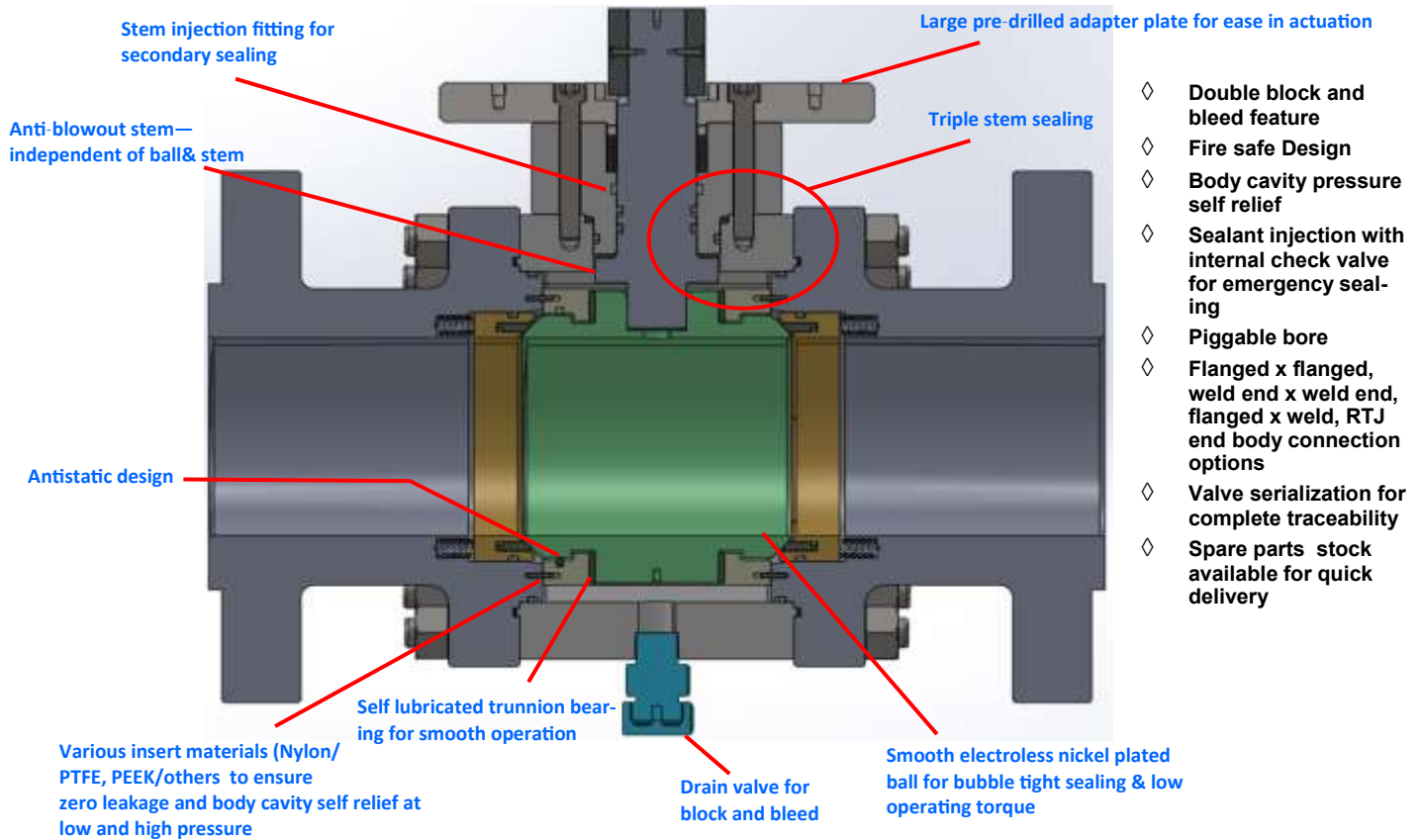

Figure 1 G1 Series 3 Piece Standard Design Features

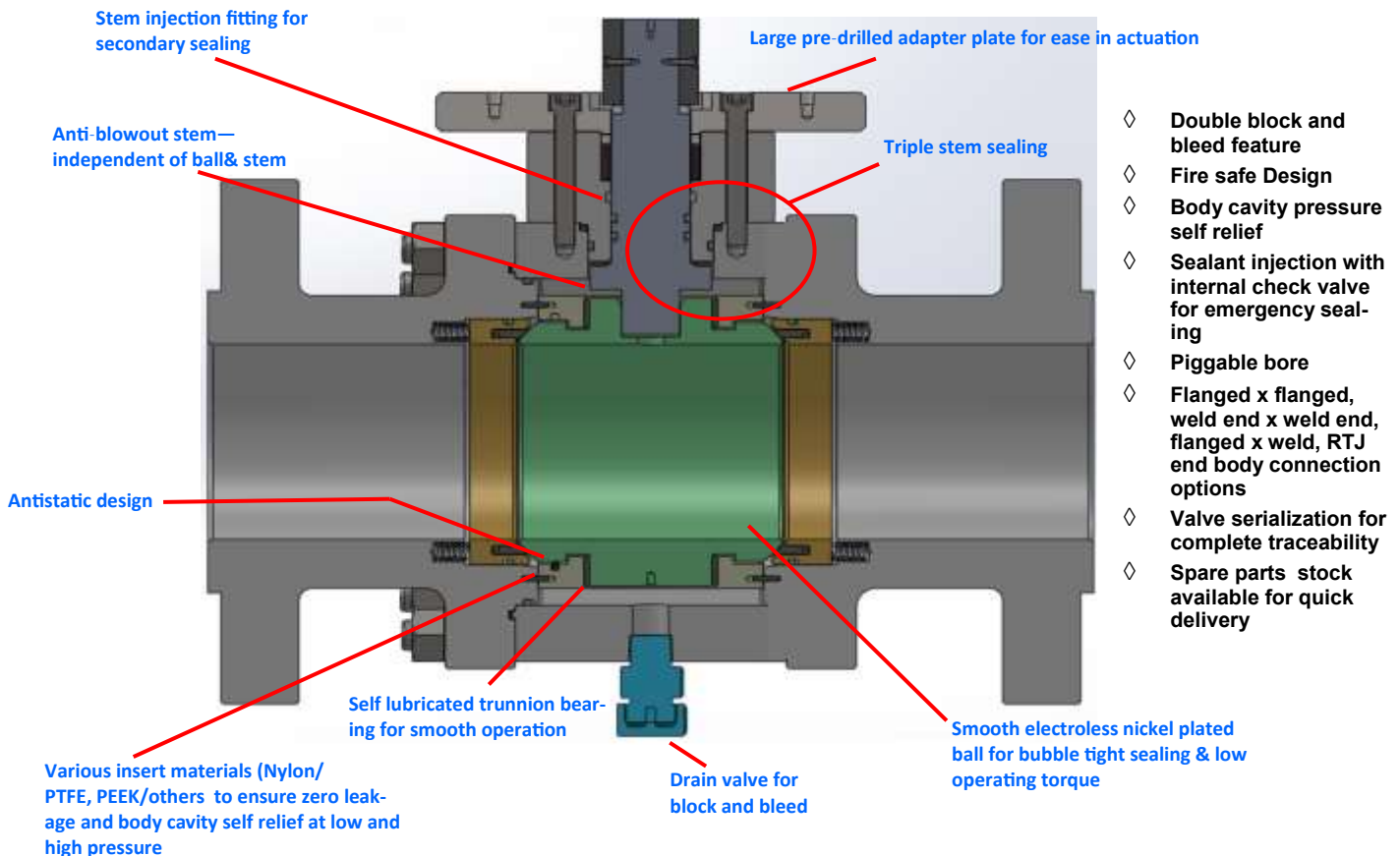

Figure 2 G2 Series 2 Piece Standard Design Features

G1 and G2 Series Standard Design Features (cont')

Manufacturing range of API 6A G series is shown in the table below. Other sizes and special classes are also available against specific request

Pressure Rating	Size												
	2 1/16	2 9/16	3 1/8	4 1/16	5 1/8	7 1/16	9	11	13 5/8	16 3/4	21 1/4	26 3/4	30
API 2000	G1; G2	G1; G2	G1; G2	G1; G2	G1; G2	G1; G2	G1; G2	G1	G1	G1	G1	G1	G1

Pressure Rating	Size												
	2 1/16	2 9/16	3 1/8	4 1/16	5 1/8	7 1/16	9	11	13 5/8	16 3/4	20 3/4	26 3/4	30
API 3000	G1	G1	G1	G1	G1	G1	G1	G1	G1	G1	G1	G1	G1

Pressure Rating	Size											
	2 1/16	2 9/16	3 1/8	4 1/16	5 1/8	7 1/16	9	11	13 5/8	16 3/4	18 3/4	21 1/4
API 5000	G1	G1	G1	G1	G1	G1	G1	G1	G1	G1	G1	G1

Pressure Rating	Size								
	1 13/16	2 1/16	2 9/16	3 1/16	4 1/16	5 1/8	7 1/16	9	11
API 10000	G1	G1	G1	G1	G1	G1	G1	G1	G1

Double Block and Bleed



All G1 series and G2 series valves are designed and manufactured to facilitate double block and bleed applications. In addition, all G1 series and G2 series can be completely flushed with valve under pressure and in the closed position. This is achieved by utilizing the drain valve and vent hole in combination. The illustration shows both the upstream pressure (Pu) and downstream pressure (Pd) being held independently from the body pressure (Pb). Both seats can hold bubble tight sealing simultaneously on both sides of the ball.

Cavity Pressure Self-relieving



When a trunnion ball valve in the closed position, media will be trapped in the body cavity. Unless this media is drained, it will be subjected to thermal expansion and contraction. All G1 series and G2 series are designed to self-relieve, allowing the media in the body to escape to the pipeline.

G1 Series and G2 Series Standards Design Features (cont')

Multiple Seals for Leakage Protection & Blow-out Proof Stem Design

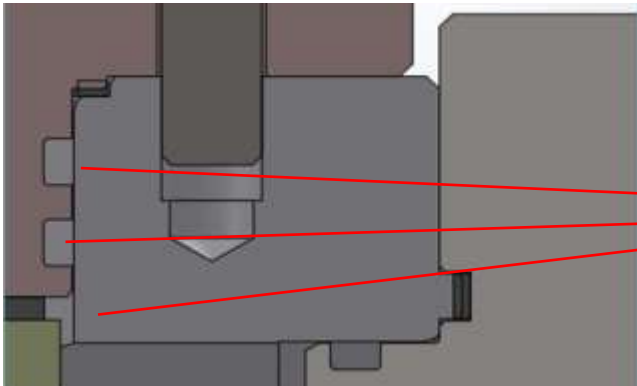

Multiple seal combination of O-ring and spiral wound gasket ensures perfect joint sealing and fire safe.

All G1 series and G2 series are designed and manufactured to facilitate **double sealing** on body/closure connection and body/gland, **triple seal** on stem/gland connection.

The blow-out proof stem enables positive stem retention.

O-ring

Emergency Sealant/Lubricant Injection

Grease injection

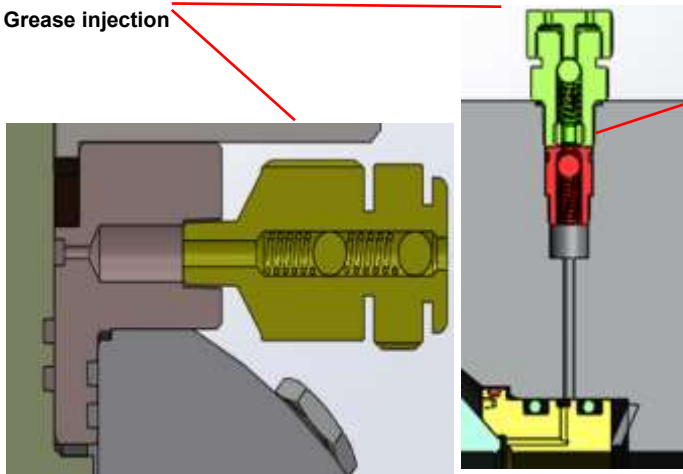

Check valve

Sealant lubricant fittings are standard on G1 series and G2 series valves. In the event of seat insert or stem seal damage, leakage can occur. Emergency sealant/lubricant injection can save the integrity of the valve by incorporating a seal around the stem or between the seat and the ball until properly serviced. These fittings also act as a lubricant port for regular maintenance.

Fire Safe Design

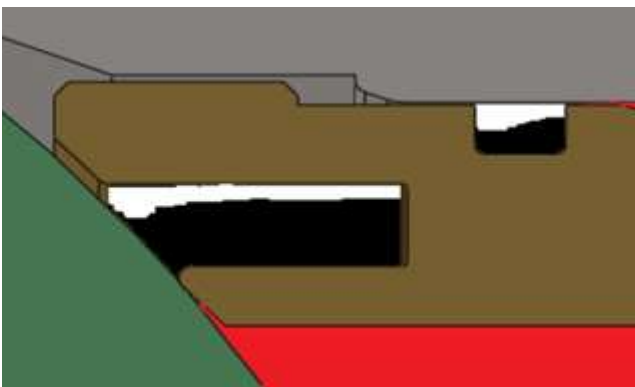

Belleville seat spring

Spring loaded floating seats maintain contact with the ball and provide tight shutoff even at low pressure differential and provide body cavity self relief.

In the event of fire, soft insert gets burnt and spring loaded seats ensure metal to metal sealing

G1 Series and G2 Series Design Features on Request

Double Piston Effect Design

MasterValve® often times provides a two-way seat design (DIB). This design allows for downstream seat sealing in the case of an upstream seat failing to seal. This design also provides for the function of testing a valve in-line and in full open position with the drain or bleed valve open to the air.

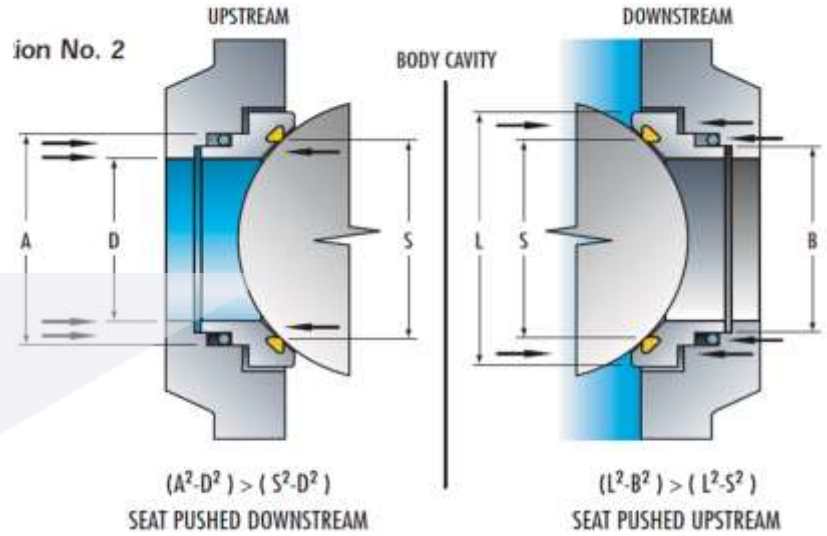

Extended Stem Design for Buried Service

Depending on customers' needs, MasterValve® could supply valves installed underground or in a remote location. These valves can be operated with an optional extended stem.

All the drain, vent, and emergency sealant connections can be operated using extended connection pipes firmly attached to the stem protective cover.

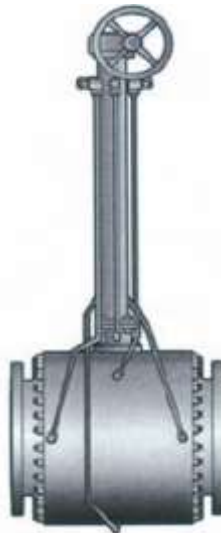

G1 Series and G2 Series Design Features on Request

Lip Seal Design/ Cryogenic Services

For service temperatures below -50°F , MasterValve[®] standard design includes lip seals and/or stem extensions using selected materials for your application. The 12" gas column shown at right is a standard feature to isolate the gear operator and stem seals from the cold media.



Live-loaded Stem Packing

For frequently cycled valves, high temperature and thermal cycling valves, critical application valves, safety or difficult located valves, and history of packing leak valve, MasterValve[®] standard valves provide a feature with live loading on the gland follower. Belleville springs are used to maintain load on the gland follower. They are typically arranged in a stack on the stud to increase the elasticity of the system.

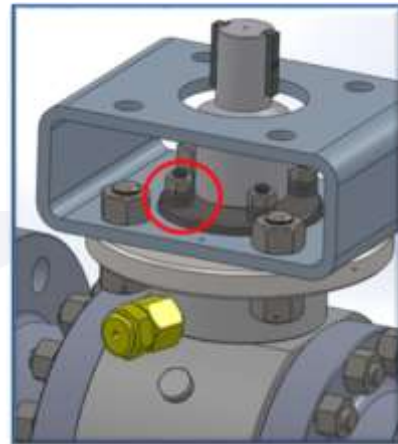

How to Order

Example: 040G1F-16-167-NV-NB. This product number (P/N) represents a 4" O1 Series (3-Piece, Side Entry, Trunnion Mounted) Ball Valve, Full Port, Raised Face, ANSI Class 600, A105/A350 LF2 Body, 316SS ball and seat, 17-4 stem, Nylon seats, Viton A seals, per NACE MR0175 Service with gear operator.

040	O1	F	1	6	1	6	7	N	V	N	G	
Bore size	Value Type	Port config.	End connection	Pressure class	Body material	Ball/Seat material	Stem material	Seat insert	Seal code	NACE option	Operator	Mod code

Bore Size

005 = 0.5"	200 = 20"	01H = 1 ¹³ / ₁₆ "
007 = 0.75"	240 = 24"	02A = 2 ¹ / ₁₆ "
010 = 1"	260 = 26"	02E = 2 ⁹ / ₁₆ "
015 = 1.5"	280 = 28"	03B = 3 ¹ / ₈ "
020 = 2"	300 = 30"	04A = 4 ¹ / ₁₆ "
030 = 3"	320 = 32"	05B = 5 ¹ / ₈ "
040 = 4"	340 = 34"	07A = 7 ¹ / ₁₆ "
060 = 6"	360 = 36"	13F = 13 ⁵ / ₈ "
080 = 8"	400 = 40"	16G = 16 ³ / ₄ "
100 = 10"	420 = 42"	18G = 18 ³ / ₄ "
120 = 12"	460 = 46"	20G = 20 ³ / ₄ "
140 = 14"	480 = 48"	21C = 21 ¹ / ₄ "
160 = 16"	560 = 56"	26G = 26 ³ / ₄ "
180 = 18"		

Valve Type

G1 = 3-piece side entry Trunnion ball valve
G2 = 2-piece side entry trunnion ball valve

Port Configuration

F = Full port
R = Reduced port

End Connection

1 = Flanged RF
2 = Flanged RTJ
3 = Welding End x Welding End
4 = Flanged RF x Welding End
5 = Flanged RTJ x Welding End
B = API 6A Type 6B Flange
C = API 6A Type 6BX Flange
O = Special

Pressure Class

1 = 150#
3 = 300#
4 = 400#
6 = 600#
9 = 900#
A = 1500#
B = 2500#
C = 2000 psi of API 6A
D = 3000 psi of API 6A
E = 5000 psi of API 6A
F = 10000 psi of API 6A
G = 15000 psi of API 6A
O = Special

Body Material

1 = A105/A350 LF2
3 = CF3/SS304L/F304
4 = CF3M/SS316L/F316L
5 = CF8/SS304
6 = CF8M/SS316/F316
7 = 17-4PH
8 = A29 4130
A = CA15/SS410/F6A
I = Inconel
M = Monel
U = Duplex SS
W = Super Duplex
O = Special
Available for other materials

Ball/Seat Material

1 = A105/A350 LF2
3 = CF3/SS304L/F304
4 = CF3M/SS316L/F316L
5 = CF8/SS304
6 = CF8M/SS316/F316
7 = 17-4PH
8 = A29 4130
A = CA15/SS410/F6A
I = Inconel
M = Monel
U = Duplex SS
W = Super Duplex
O = Special
Available for other materials

How to Order

Example: 040G1F-16-167-NV-NB. This product number (P/N) represents a 4" O1 Series (3-Piece, Side Entry, Trunnion Mounted) Ball Valve, Full Port, Raised Face, ANSI Class 600, A105/A350 LF2 Body, 316SS ball and seat, 17-4 stem, Nylon seats, Viton A seals, per NACE MR0175 Service with gear operator

040	O1	F	1	6	1	6	7	N	V	N	G	
Bore size	Value Type	Port config.	End connection	Pressure class	Body material	Ball/Seat material	Stem material	Seat insert	Seal code	NACE option	Operator	Mod code

Stem Material

1 = A105/A350 LF2
 3 = CF3/SS304L/F304
 4 = CF3M/SS316L/F316L
 5 = CF8/SS304
 6 = CF8M/SS316/F316
 7 = 17-4 PH
 8 = A29 4130
 A = CA15/SS410/F6A
 I = Inconel
 M = Monel
 U = Duplex SS
 W = Super Duplex
 O = Special
 Available for other materials

Seat Insert

B = Buna-N
 G = Glass Filled PTFE
 N = Nylon
 M = Molon
 D = Devlon®
 E = EPDM
 H = HNBR
 P = Peek
 R = Low Temp Buna-N
 V = Viton® A
 W = Viton® B
 T = Lip Seal TFE
 U = Vtion GLT
 Y = Viton GF
 O = Special
 Available for other materials

Seal Code

B = Buna-N
 G = Glass Filled PTFE
 N = Nylon
 D = Devlon®
 E = EPDM
 H = HNBR
 P = Peek
 R = Low Temp Buna-N
 V = Viton® A
 W = Viton® B
 T = Lip Seal TFE
 U = Vtion GLT
 Y = Viton GF
 O = Special
 Available for other materials

NACE Option

N = NACE
 S = Non NACE

Operator

A = Actuator
 B = Bare stem
 G = Gear operator
 L = Lever
 O = Special

Mod Code

Exx = Stem extension xx inches
 xxx = Modification code xxx

How to Order

Example: 060G1R-29-167-PV-NG. This product number represents a 6" O1 Series (3-Piece, Side Entry, Trunnion Mounted) Ball Valve, Reduced Port, Flanged RTJ, ANSI Class 900, A105/A350 LF2 Body, 316SS ball and seat, 17-4PH stem, Peek seats, Viton® A seals, Fire Tested with Emergency Grease Seals, for NACE MR0175 Service with gear operator.

Example: 060G2F-16-667-PT-NB. This product number represents a 6" O2 Series (2-Piece, Side Entry, Trunnion Mounted) Ball Valve, Full Port, Raised Face, ANSI Class 600, 316SS Body, 316SS ball and seat, 17-4PH stem, Peek seats, Lip seals, Fire Tested with Emergency Grease Seals, for NACE MR0175 Service with bear stem.

Example: 040G2R-13-166-GW-NL. This product number represents a 4" O2 Series (2-Piece, Side Entry, Trunnion Mounted) Ball Valve, Reduced Port, Raised Face, ANSI Class 300, A105/A350 LF2 Body, 316SS ball and seat, 316SS stem, Glass filled PTFE seats, Viton® B seals, Fire Tested with Emergency Grease Seals, for NACE MR0175 Service and lever operator.

Example: 200G1F-46-UUI-ZT-NA. This product number represents a 20" O1 Series (3-Piece, Side Entry, Trunnion Mounted) Ball Valve, Full Port, Flange RF x Welding end, ANSI Class 600, Duplex SS Body, Metal-seated Duplex SS ball and seat with tungsten carbide coating, Inconel stem, Lip seals, Fire Tested with Emergency Grease Seals, for NACE MR0175 Service and actuator operated.

Example: 07AG1F-BC-167-NV-SA. This feature number represents a 7 1/16" O1 Series (3-Piece, Side Entry, Trunnion Mounted) Ball Valve, Full Port, API 6A Type 6B Flange, 2000 psi, A105/A350 LF2 Body, 316SS ball and seat, 17-4PH stem, Nylon seats, Viton® A seals, Fire Tested with Emergency Grease Seals, for Non NACE and actuator operator.

G Series Material Options

G1 series and G2 series ball valves offer a full range of carbon, alloy and stainless materials. Our standard valves are A105/A350 LF2 steel, B7H/2HM fasteners, Viton® seals, and painted with a durable coating. Material test reports in accordance with EN10204.3 are available on each serialized valve. In addition, all G1 series and G2 series trunnion ball valves, with standard trim, have been proven reliable, and fully comply with NACE MR0175. Customers must provide application specific operating conditions for accurate sizing and selection. Inclusive to above, valves with bore diameters 4" and smaller are supplied standard with stainless steel ball, seats and stems. Materials type selected may vary depending on design requirements.

Part	Material Options
Body & Closure	A105/A350 LF2 / F316 / Duplex SS / Inconel
Ball & Seat	A105/A350 LF2 with ENPC / A351 CF8M / F316 / 17-4PH / Duplex SS / Inconel / Monel
Stem	ASTM A29 Grade 4130 with ENP / F316 / A564 Type 630 / A479 SS 410 / Duplex SS / Inconel
Seat insert	Nylon / Devlon / Glass filled PTFE / Peek
Gland	ASTM A29 Grade 4130 with ENP / F316 / A564 Type 630 / Duplex SS / Inconel
Trunnion Bearing	Carbon steel or Stainless steel + PTFE coated
Seal	Vtion® / Nitril / Buna / HNBR / EPDM / Viton GLT / Kalras / Lip Seal
Studs / Cap Screws	A193 B7M / A320 L7M / A193 B8M
Nut	A 194 2HM / A194 7M / A194 8M

Note: Materials not listed above can be offered on request

G1 Series and G2 Series Pressure Temperature Ratings

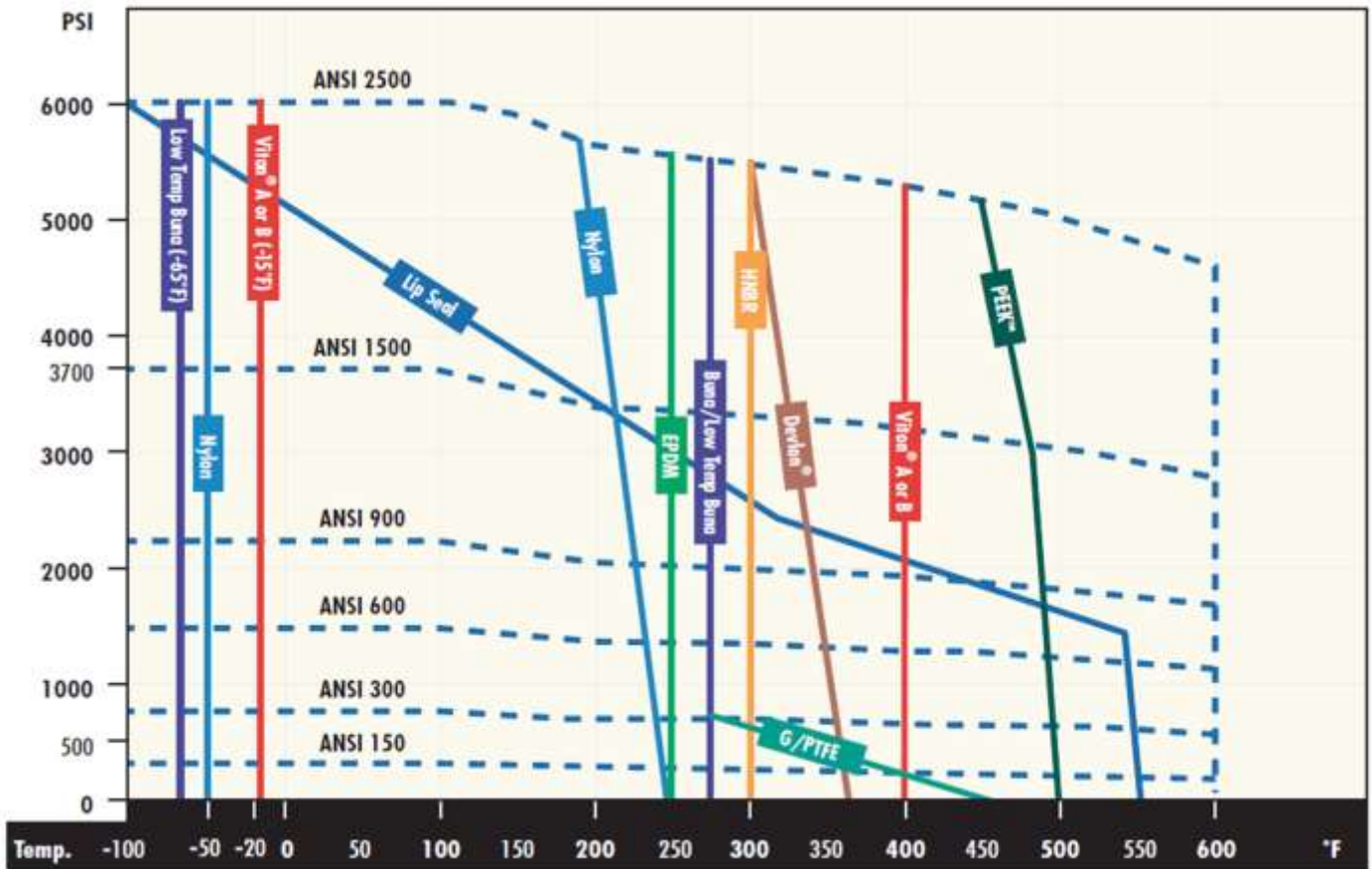

Tough Ball Valve for Toughest Flow

G1 Series Standard Design General Assembly

No.	Description
1	Body
2	Closure/Flanged End
4	Ball
5	Stem
6	Seat Ring Sub Assembly
9	Bearing Retainer
10	Gland
11	Bushing
12	Adapter Plate
18	Gland Pin
20	Stem Key
22	Ball Thrust Washer
25	Stem Thrust Washer
28	Ball Bearing
31	Seat Spring
32	Body O-ring
33	Seat O-ring
34	Stem O-ring
35	Gland & Trunnion O-ring
36	Emergency Sealant O-ring
38	Location Stud
39	Body Stud
40	Body Nut
43	Gland Cap Screw
44	Adapter Plate Cap Screw
45	Trunnion Cap Screw
46	Stem Key Cap Screw
47	Gear Stud
48	Gear/Adapter Plate Nut
49	Stem Grease Fitting
50	Seat Grease Fitting
51	Check Valve
52	Vent Plug
53	Lifting Lug Stud
54	Drain Valve
55	Lifting Lug
56	Support Leg
57	Worm Gear Operator
60	Handwheel
64	Name Plate
65	Drive Screw
70	Body Gasket
71	Gland & Trunnion Gasket
72	Stem Packing

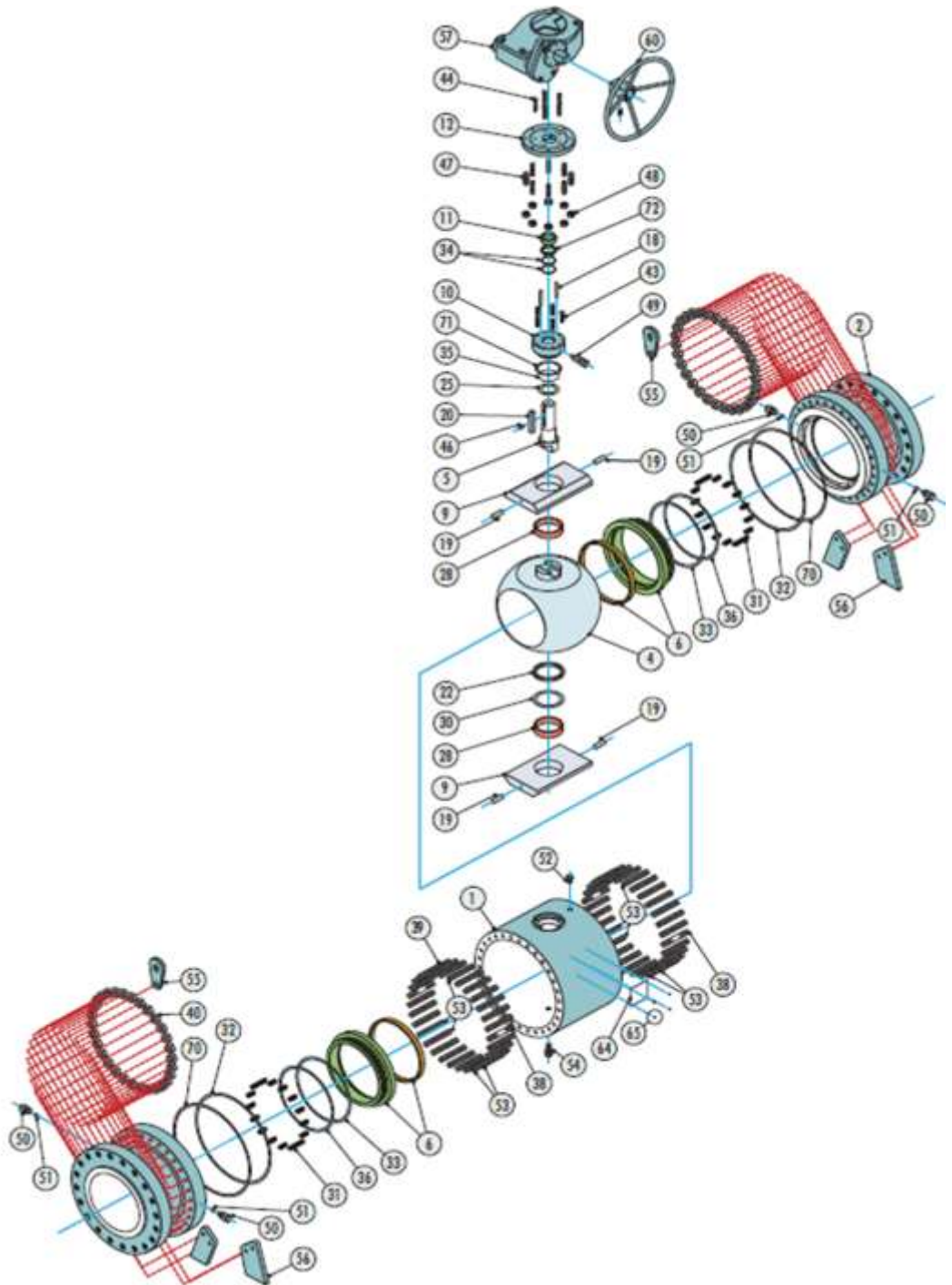

G1 & G2 Series Ball Valves' Dimensional Data

The charts and tables below depict G1 & G2 Series ball valves' dimensional data.
Please contact Master Valve® Salesperson for Top Works data.
* available per request.

2"-4" Class 150 • 2" Class 300

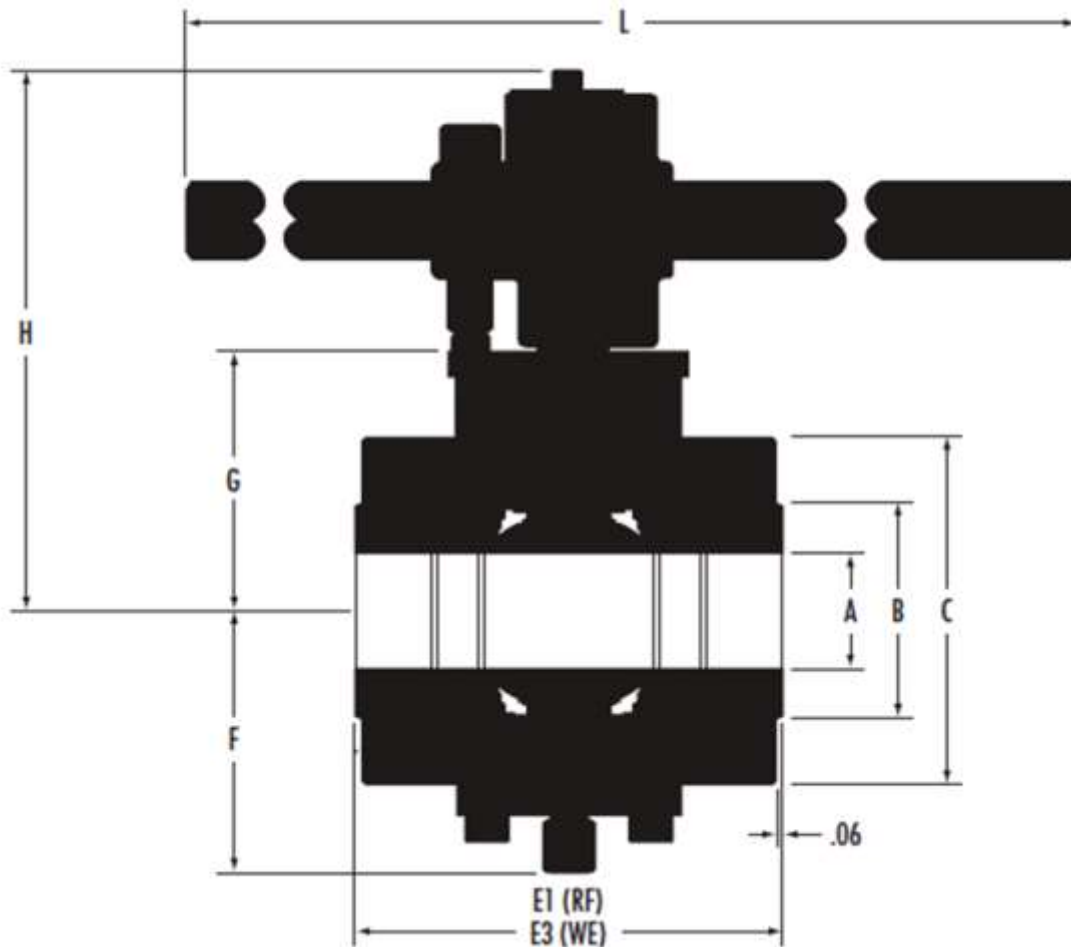

Class 150 2"FP-4"FP (in.)

Size	A	B	C	D1	E1-RF	E3-WE	F	G	H	L
2x2	2.00x2.00	3.62	6.00	NA	7.00	8.50	4.89	4.87	9.55	30
3x3	3.00x3.00	5.00	7.87	NA	8.00	11.12	5.87	5.94	10.92	30
4x4	4.00x4.00	6.19	9.49	NA	9.00	12.00	7.30	7.35	12.93	48

NOTES: Sizes 6"x6" and larger are gear operated. Dimension "F" includes drain plug and support brackets.

Class 300 2"FP (in.)

Size	A	B	C	D1	E1-RF	E3-WE	F	G	H	L
2x2	2.00x2.00	3.62	6.50	NA	8.50	8.50	4.89	4.87	9.55	30

NOTES: Sizes 6"x6" and larger are gear operated. Dimension "F" includes drain plug and support brackets.

G1 & G2 Series Ball Valves' Dimensional Data

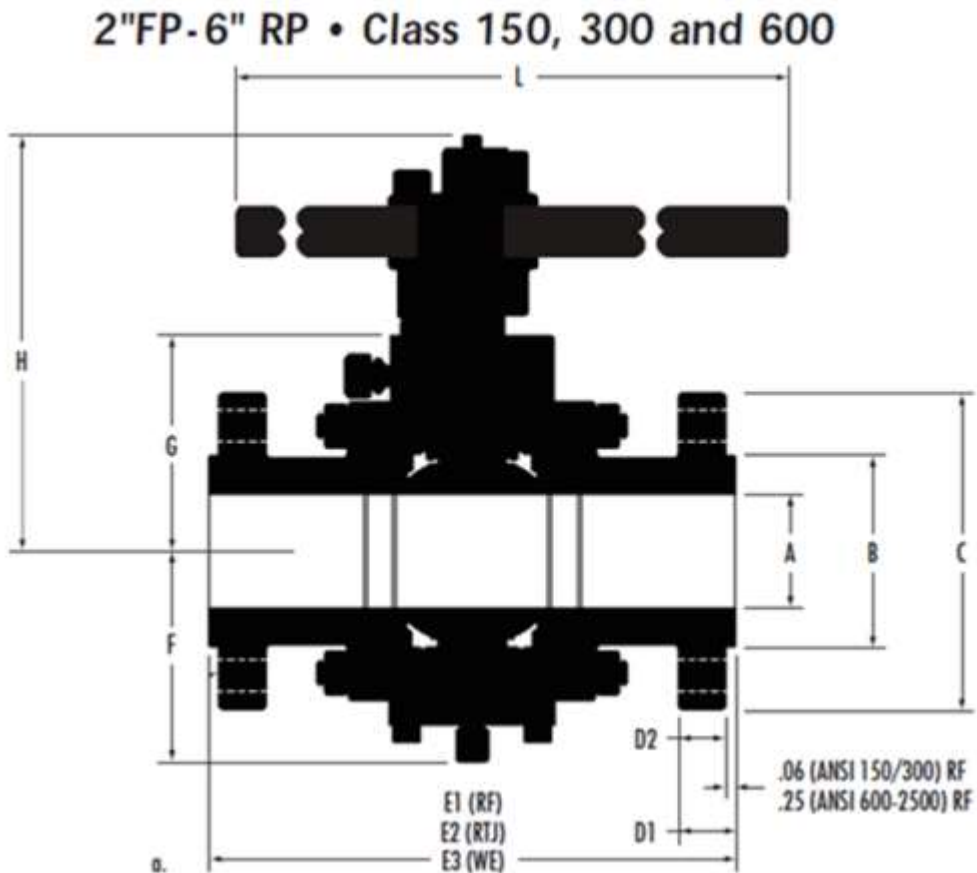

Class 150 6"RP (in.)

Size	A	B	C	D1	E1-RF	E2-RTJ	E3-WE	F	G	H	L
6x4	6.00x4.00	8.50	11.00	1.00	15.50	16.00	18.00	7.30	7.35	12.93	48

Class 300 3"RP-6"RP (in.)

Size	A	B	C	D1	E1-RF	E2-RTJ	E3-WE	F	G	H	L
3x2	3.00x2.00	5.00	8.25	1.12	11.12	11.75	11.12	4.89	4.87	9.55	30
3x3	3.00x3.00	5.00	8.25	1.12	11.12	11.75	11.12	5.87	5.94	10.92	30
4x3	4.00x3.00	6.19	10.00	1.25	12.00	12.62	12.00	5.87	5.94	10.92	30
4x4	4.00x4.00	6.19	10.00	1.25	12.00	12.62	12.00	7.30	7.35	12.93	48
6x4	6.00x4.00	8.50	12.50	1.44	15.88	16.50	18.00	7.30	7.35	12.93	48

Class 600 2"FP-6"RP (in.)

Size	A	B	C	D2	E1-RF	E2-RTJ	E3-WE	F	G	H	L
2x2	2.00x2.00	3.62	6.50	1.00	11.50	11.62	11.50	4.89	4.87	9.55	30
3x2	3.00x2.00	5.00	8.25	1.25	14.00	14.12	14.00	4.89	4.87	9.55	30
3x3	3.00x3.00	5.00	8.25	1.25	14.00	14.12	14.00	5.87	5.94	10.92	30
4x3	4.00x3.00	6.19	10.75	1.50	17.00	17.12	17.00	5.87	5.94	10.92	30
4x4	4.00x4.00	6.19	10.75	1.50	17.00	17.12	17.00	7.30	7.35	12.93	48
6x4	6.00x4.00	8.50	14.00	1.88	22.00	22.12	22.00	7.30	7.35	12.93	48

G1 & G2 Series Ball Valves' Dimensional Data

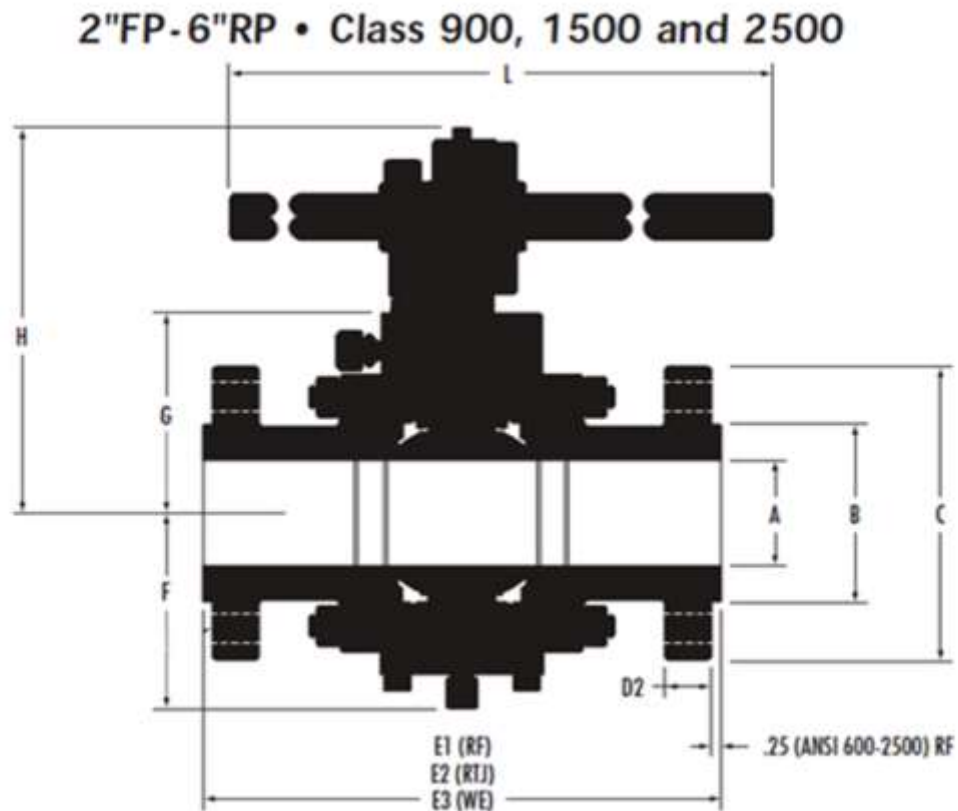

Class 900 2"FP-6"RP (in.)

Size	A	B	C	D2	E1-RF	E2-RTJ	E3-WE	F	G	H	L
2x2	2.00x2.00	3.62	8.50	1.50	14.50	14.62	14.50	4.89	4.87	9.55	30
3x2	3.00x2.00	5.00	9.50	1.50	15.00	15.12	15.00	4.89	4.87	9.55	30
3x3	3.00x3.00	5.00	9.50	1.50	15.00	15.12	15.00	5.87	5.94	10.92	30
4x3	4.00x3.00	6.19	11.50	1.75	18.00	18.12	18.00	5.87	5.94	10.92	30
4x4	4.00x4.00	6.19	11.50	1.75	18.00	18.12	18.00	7.30	7.35	12.93	48
6x4	6.00x4.00	8.50	15.00	2.19	24.00	24.12	24.00	7.30	7.35	12.93	48

Class 1500 2"FP-6"RP (in.)

Size	A	B	C	D2	E1-RF	E2-RTJ	E3-WE	F	G	H	L
2x2	2.00x2.00	3.62	8.50	1.50	14.50	14.62	14.50	5.32	5.47	10.30	30
3x2	3.00x2.00	5.00	10.50	1.88	18.50	18.62	18.50	5.32	5.47	10.30	30
3x3	3.00x3.00	5.00	10.50	1.88	18.50	18.62	18.50	6.89	6.42	11.60	30
4x3	4.00x3.00	6.19	12.25	2.12	21.50	21.62	21.50	6.89	6.42	11.60	30
4x4	4.00x4.00	6.19	12.25	2.12	21.50	21.62	21.50	8.14	7.88	13.75	48
6x4	5.75x4.00	8.50	15.50	3.25	27.75	28.00	27.75	8.14	7.88	13.75	48

Class 2500 2"FP-6"RP (in.)

Size	A	B	C	D2	E1-RF	E2-RTJ	E3-WE	F	G	H	L
2x2	1.75x1.75	3.62	9.25	2.00	17.75	17.87	17.75	6.39	7.25	13.19	30
3x2	2.50x1.75	5.00	12.00	2.62	22.75	23.00	22.75	6.39	7.25	13.19	30
3x3	2.50x2.50	5.00	12.00	2.62	22.75	23.00	22.75	8.20	8.42	14.68	30
4x3	3.50x2.50	6.19	14.00	3.00	26.50	26.88	26.50	8.20	8.42	14.68	30
4x4	3.50x3.50	6.19	14.00	3.00	26.50	26.88	26.50	9.43	10.56	16.93	48
6x4	5.25x3.50	8.50	19.00	4.25	36.00	36.50	36.00	9.43	10.56	16.93	48

G1 & G2 Series Ball Valves' Dimensional Data

6"FP-14"RP • Class 150, 300 and 600

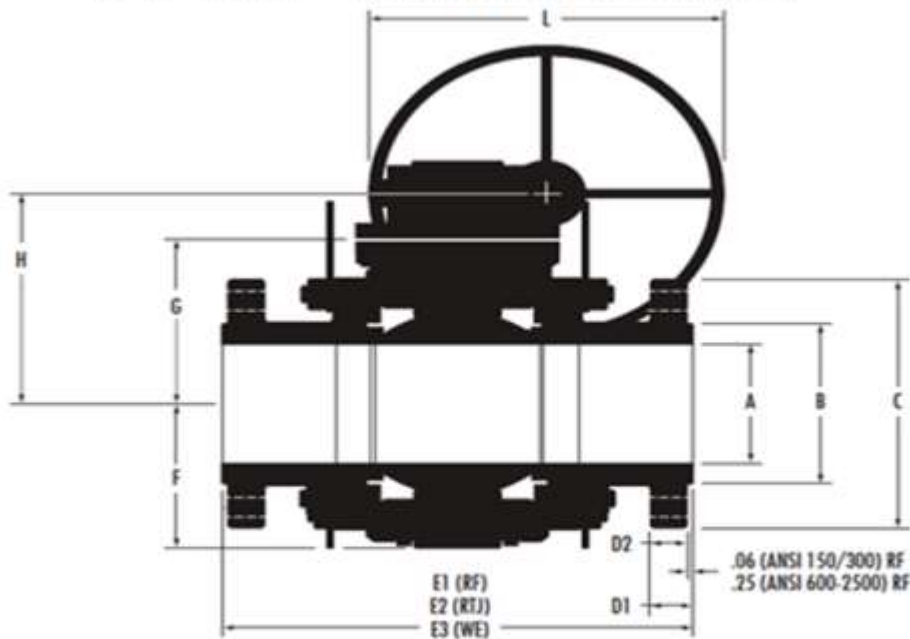

Class 150 6"FP-14"RP (in.)

Size	A	B	C	D1	E1-RF	E2-RTJ	E3-WE	F	G	H	L
6x6	6.00x6.00	8.50	11.00	1.00	15.50	16.00	18.00	7.25	8.48	10.63	24
8x6	8.00x6.00	10.62	13.50	1.12	18.00	18.50	20.50	7.25	8.48	10.63	24
8x8	8.00x8.00	10.62	13.50	1.12	18.00	18.50	20.50	8.72	10.13	12.26	24
10x8	10.00x8.00	12.75	16.00	1.19	21.00	21.50	22.00	8.72	10.13	12.26	24
10x10	10.00x10.00	12.75	16.00	1.19	21.00	21.50	22.00	10.56	11.96	14.09	24
12x10	12.00x10.00	15.00	19.00	1.25	24.00	24.50	25.00	10.56	11.96	14.09	24
12x12	12.00x12.00	15.00	19.00	1.25	24.00	24.50	25.00	12.26	13.75	15.88	24
14x12	13.25x12.00	16.25	21.00	1.38	27.00	27.50	30.00	12.26	13.75	15.88	24

Class 300 6"FP-14"RP (in.)

Size	A	B	C	D1	E1-RF	E2-RTJ	E3-WE	F	G	H	L
6x6	6.00x6.00	8.50	12.50	1.44	15.88	16.50	18.00	7.25	8.48	10.63	24
8x6	8.00x6.00	10.62	15.00	1.62	19.75	20.38	20.50	7.25	8.48	10.63	24
8x8	8.00x8.00	10.62	15.00	1.62	19.75	20.38	20.50	8.72	10.13	12.26	24
10x8	10.00x8.00	12.75	17.50	1.88	22.38	23.00	22.00	8.72	10.13	12.26	24
10x10	10.00x10.00	12.75	17.50	1.88	22.38	23.00	22.00	10.56	11.96	14.09	24
12x10	12.00x10.00	15.00	20.50	2.00	25.50	26.12	25.00	10.56	11.96	14.09	24
12x12	12.00x12.00	15.00	20.50	2.00	25.50	26.12	25.00	12.26	13.75	15.88	24
14x12	13.25x12.00	16.25	23.00	2.12	30.00	30.62	30.00	12.26	13.75	15.88	30

Class 600 6"FP-14"RP (in.)

Size	A	B	C	D2	E1-RF	E2-RTJ	E3-WE	F	G	H	L
6x6	6.00x6.00	8.50	14.00	1.88	22.00	22.12	22.00	7.25	8.48	10.63	24
8x6	8.00x6.00	10.62	16.50	2.19	26.00	26.12	26.00	7.25	8.48	10.63	24
8x8	8.00x8.00	10.62	16.50	2.19	26.00	26.12	26.00	10.00	11.57	13.70	24
10x8	10.00x8.00	12.75	20.00	2.50	31.00	31.12	31.00	10.00	11.57	13.70	24
10x10	10.00x10.00	12.75	20.00	2.50	31.00	31.12	31.00	11.74	13.32	15.45	24
12x10	12.00x12.00	15.00	22.00	2.62	33.00	33.12	33.00	11.74	13.32	15.45	24
12x12	12.00x12.00	15.00	22.00	2.62	33.00	33.12	33.00	13.86	14.94	21.52	30
14x12	13.25x12.00	16.25	23.75	2.75	35.00	35.12	35.00	13.86	14.94	21.52	30

G1 & G2 Series Ball Valves' Dimensional Data

6"FP-14"RP • Class 900 and 1500

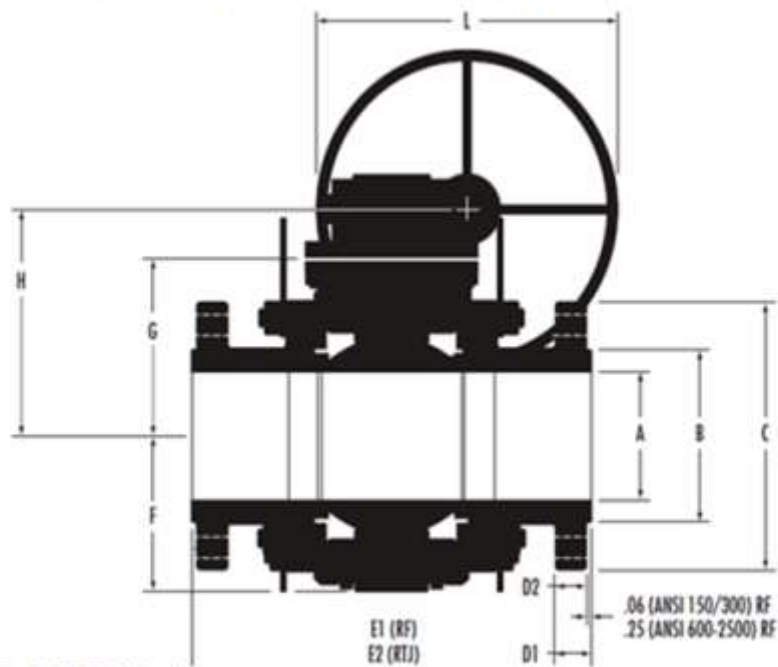

Class 900 6"FP-14"RP (in.)

Size	A	B	C	D2	E1-RF	E2-RTJ	E3-WE	F	G	H	N	M	P	L
6x6	6.00x6.00	8.50	15.00	2.19	24.00	24.12	24.00	8.62	10.01	12.14	12	1.25	12.50	24
8x6	8.00x6.00	10.62	18.50	2.50	29.00	29.12	29.00	8.62	10.01	12.14	12	1.50	15.50	24
8x8	8.00x8.00	10.62	18.50	2.50	29.00	29.12	29.00	10.00	11.57	13.70	12	1.50	15.50	24
10x8	10.00x8.00	12.75	21.50	2.75	33.00	33.12	33.00	10.00	11.57	13.70	16	1.50	18.50	24
10x10	10.00x10.00	12.75	21.50	2.75	33.00	33.12	33.00	11.74	13.32	19.90	16	1.50	18.50	30
12x10	12.00x12.00	15.00	24.00	3.12	38.00	38.12	38.00	11.74	13.32	19.90	20	1.50	21.00	30
12x12	12.00x12.00	15.00	24.00	3.12	38.00	38.12	38.00	13.86	14.94	21.52	20	1.50	21.00	30
14x12	12.75x12.00	16.25	25.25	3.38	40.50	40.88	40.50	13.86	14.94	21.52	20	1.62	22.00	30

Class 1500 6"FP-14"RP (in.)

Size	A	B	C	D2	E1-RF	E2-RTJ	E3-WE	F	G	H	N	M	P	L
6x6	5.75x5.75	8.50	15.50	3.25	27.75	28.00	27.75	9.72	10.67	12.80	12	1.50	12.50	24
8x6	7.63x5.75	10.62	19.00	3.62	32.75	33.13	32.75	9.72	10.67	12.80	12	1.75	15.50	24
8x8	7.63x7.63	10.62	19.00	3.62	32.75	33.13	32.75	12.16	12.88	19.46	12	1.75	15.50	30
10x8	9.50x7.63	12.75	23.00	4.25	39.00	39.38	39.00	12.16	12.88	19.46	12	2.00	19.00	30
10x10	9.50x9.50	12.75	23.00	4.25	39.00	39.38	39.00	14.40	15.48	22.06	12	2.00	19.00	30
12x10	11.38x9.50	15.00	26.50	4.88	44.50	45.12	44.50	14.40	15.48	22.06	16	2.12	22.50	30
12x12	11.38x11.38	15.00	26.50	4.88	44.50	45.12	44.50	16.98	17.83	24.41	16	2.12	22.50	30
14x12	12.50x11.38	16.25	29.50	5.25	49.50	50.25	49.50	16.98	17.83	24.41	16	2.38	25.00	30

Class 2500 6"FP-12"RP (in.)

Size	A	B	C	D2	E1-RF	E2-RTJ	E3-WE	F	G	H	N	M	P	L
6x6	5.25x5.25	8.50	19.00	4.25	36.00	36.50	36.00	12.74	12.70	19.28	8	2.12	14.50	30
8x6	7.14x5.25	10.62	21.75	5.00	40.25	40.87	40.25	12.74	12.70	19.28	12	2.12	17.25	30
8x8	7.14x7.14	10.62	21.75	5.00	40.25	40.87	40.25	15.22	16.63	18.76	12	2.12	17.25	30
10x8	8.88x7.14	12.75	26.50	6.50	50.00	50.88	50.00	15.22	16.63	18.76	12	2.62	21.25	30
10x10	8.88x8.88	12.75	26.50	6.50	50.00	50.88	50.00	19.73	18.25	24.83	12	2.62	21.25	30
12x10	10.50x8.88	15.00	30.00	7.25	56.00	56.88	56.00	19.73	18.25	24.83	12	2.88	24.38	30
12x12	10.50x10.50	15.00	30.00	7.25	56.00	56.88	56.00	22.06	20.79	27.69	12	2.88	24.38	30

G1 & G2 Series Ball Valves' Dimensional Data

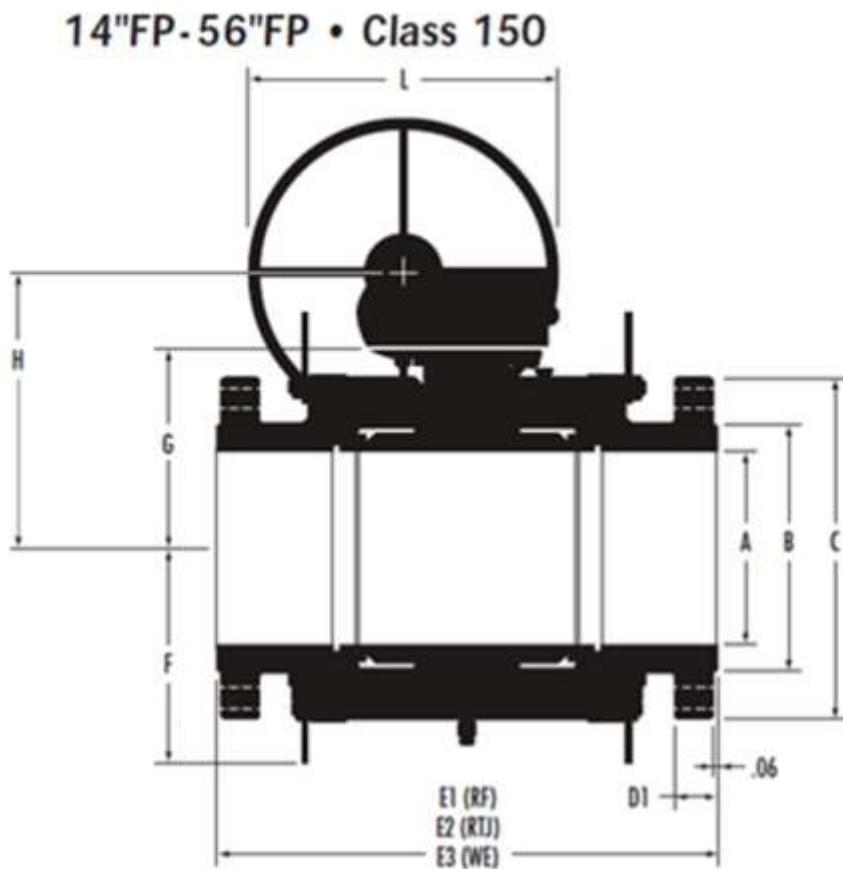

Class 150 14"FP-56"FP (in.)

Size	A	B	C	D1	E1-RF	E2-RTJ	E3-WE	F	G	H	L
14x14	13.25x13.25	16.25	21.00	1.38	27.00	27.50	30.00	14.92	15.18**	20.89	30
16x14	15.25x13.25	18.50	23.50	1.44	30.00	30.50	33.00	16.60	15.18**	20.89	30
16x16	15.25x15.25	18.50	23.50	1.44	30.00	30.50	33.00	16.60	15.89	22.47	30
18x16	17.25x15.25	21.00	25.00	1.56	34.00	34.50	36.00	21.05	15.89	22.47	30
18x18	17.25x17.25	21.00	25.00	1.56	34.00	34.50	36.00	21.05	19.76	26.34	30
20x18	19.25x17.25	23.00	27.50	1.69	36.00	36.50	39.00	19.67	19.76	26.34	30
20x20	19.25x19.25	23.00	27.50	1.69	36.00	36.50	39.00	19.67	20.20	26.78	30
24x20	23.25x19.25	27.25	32.00	1.88	42.00	42.50	45.00	22.75	20.20	26.78	30
24x24	23.25x23.25	27.25	32.00	1.88	42.00	42.50	45.00	22.75	23.34	30.24	30
30x30	29.00x29.00	33.75	38.75	2.88	51.00	*	55.00	31.25	32.08	38.98	30
36x36	34.50x34.50	40.25	46.00	3.50	60.00	*	68.00	34.39	35.83	42.73	30
40x40	38.50x38.50	44.25	50.75	3.50	72.83	*	70.08	36.54	37.13	*	*
44x44	42.32x42.32	49.00	55.25	3.94	76.77	*	74.80	39.76	40.39	*	*
48x48	45.98x45.98	53.50	59.50	4.19	85.83	*	82.68	41.77	43.19	*	*
56x56	53.62x53.62	62.00	68.75	4.82	90.55	*	88.58	48.50	49.92	*	*

G1 & G2 Series Ball Valves' Dimensional Data

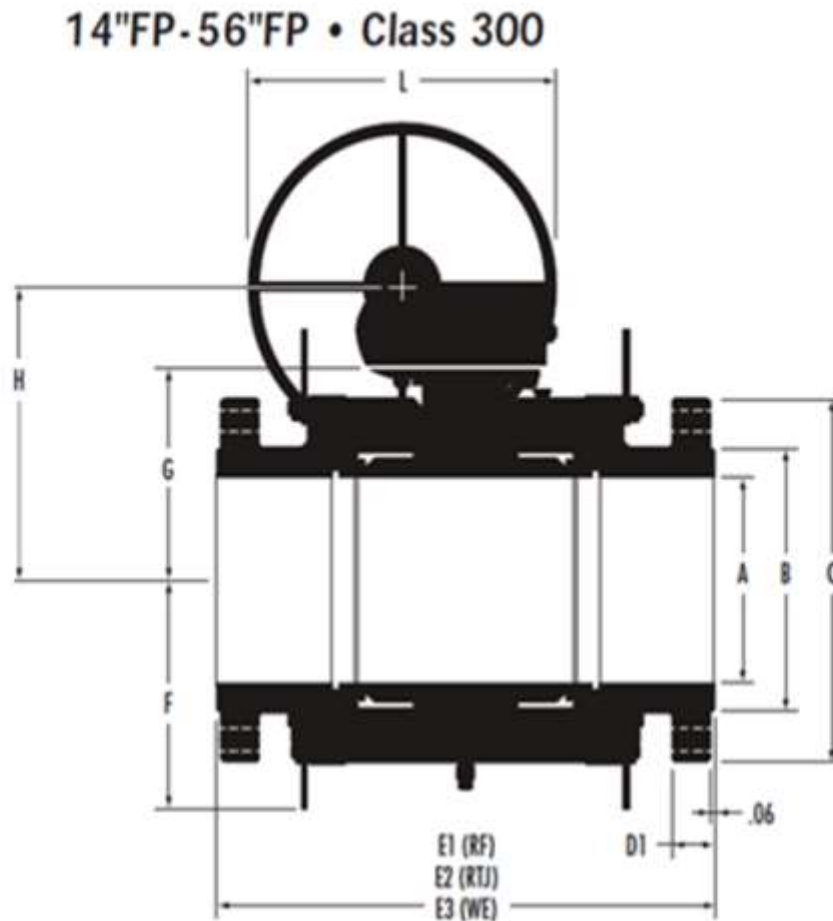

Class 300 14"FP-56"FP (in.)

Size	A	B	C	D1	E1-RF	E2-RTJ	E3-WE	F	G	H	L
14x14	13.25x13.25	16.25	23.00	2.12	30.00	30.62	30.00	14.92	14.31	20.89	30
16x14	15.25x13.25	18.50	25.50	2.25	33.00	33.62	33.00	16.60	14.31	20.89	30
16x16	15.25x15.25	18.50	25.50	2.25	33.00	33.62	33.00	16.60	15.89	22.47	30
18x16	17.25x15.25	21.00	28.00	2.38	36.00	36.62	36.00	21.05	15.89	22.47	30
18x18	17.25x17.25	21.00	28.00	2.38	36.00	36.62	36.00	21.05	19.76	26.34	30
20x18	19.25x17.25	23.00	30.50	2.50	39.00	39.75	39.00	19.67	19.76	26.34	30
20x20	19.25x19.25	23.00	30.50	2.50	39.00	39.75	39.00	19.67	20.20	26.78	30
24x20	23.25x19.25	27.25	36.00	2.75	45.00	45.88	45.00	22.75	20.20	26.78	30
24x24	23.25x23.25	27.25	36.00	2.75	45.00	45.88	45.00	22.75	23.34	30.24	30
30x30	29.00x29.00	33.75	43.00	3.62	55.00	56.00	55.00	31.25	32.08	38.98	30
36x36	34.50x34.50	40.25	50.00	4.12	68.00	69.12	68.00	34.39	35.83	42.73	30
40x40	38.50x38.50	42.75	48.75	4.44	72.83	*	70.08	36.54	37.13	*	*
44x44	42.32x42.32	47.00	53.25	4.82	76.77	*	74.80	39.76	40.39	*	*
48x48	45.98x45.98	51.25	57.75	5.19	85.83	*	82.68	41.77	43.19	*	*
56x56	53.62x53.62	59.75	67.25	6.00	90.55	*	88.58	48.50	49.92	*	*

G1 & G2 Series Ball Valves' Dimensional Data

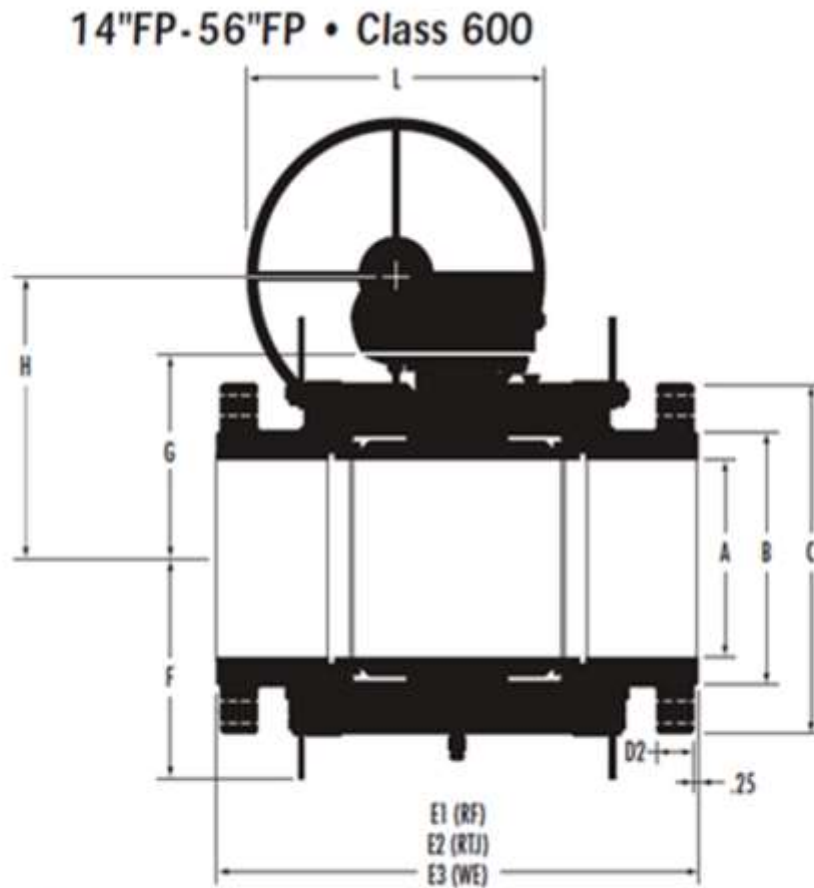

Class 600 14"FP-56"FP (in.)

Size	A	B	C	D2	E1-RF	E2-RTJ	E3-WE	F	G	H	L
14x14	13.25x13.25	16.25	23.75	2.75	35.00	35.12	35.00	14.92	14.31	20.89	30
16x14	15.25x13.25	18.50	27.00	3.00	39.00	39.12	39.00	16.33	14.31	20.89	30
16x16	15.25x15.25	18.50	27.00	3.00	39.00	39.12	39.00	16.33	15.89	22.47	30
18x16	17.25x15.25	21.00	29.25	3.25	43.00	43.12	43.00	21.05	15.89	22.47	30
18x18	17.25x17.25	21.00	29.25	3.25	43.00	43.12	43.00	21.05	19.76	26.34	30
20x18	19.25x17.25	23.00	32.00	3.50	47.00	47.25	47.00	19.67	19.76	26.34	30
20x20	19.25x19.25	23.00	32.00	3.50	47.00	47.25	47.00	19.67	20.09	26.99	30
24x20	23.25x19.25	27.25	37.00	4.00	55.00	55.38	55.00	23.13	20.09	26.99	30
24x24	23.25x23.25	27.25	37.00	4.00	55.00	55.38	55.00	23.13	25.35 ⁽¹⁾	31.25	30
30x30	29.00x29.00	33.75	44.50	4.50	65.00	65.50	65.00	31.25	32.08	38.98	30
36x36	34.50x34.50	40.25	51.75	4.88	82.00	82.64	82.01	34.39	35.83	42.73	30
40x40	38.50x38.50	43.75	52.00	6.25	78.74	*	74.80	37.13	37.60	*	*
44x44	42.32x42.32	48.25	57.25	6.81	86.61	*	80.71	40.55	41.73	*	*
48x48	45.98x45.98	52.50	62.75	7.44	94.49	*	85.83	43.50	44.69	*	*
56x56	53.62x53.62	60.75	73.00	8.56	*	*	93.90	49.37	50.79	*	*

G1 & G2 Series Ball Valves' Dimensional Data

14"FP-48"FP Class 900 • 14"FP-24"FP Class 1500

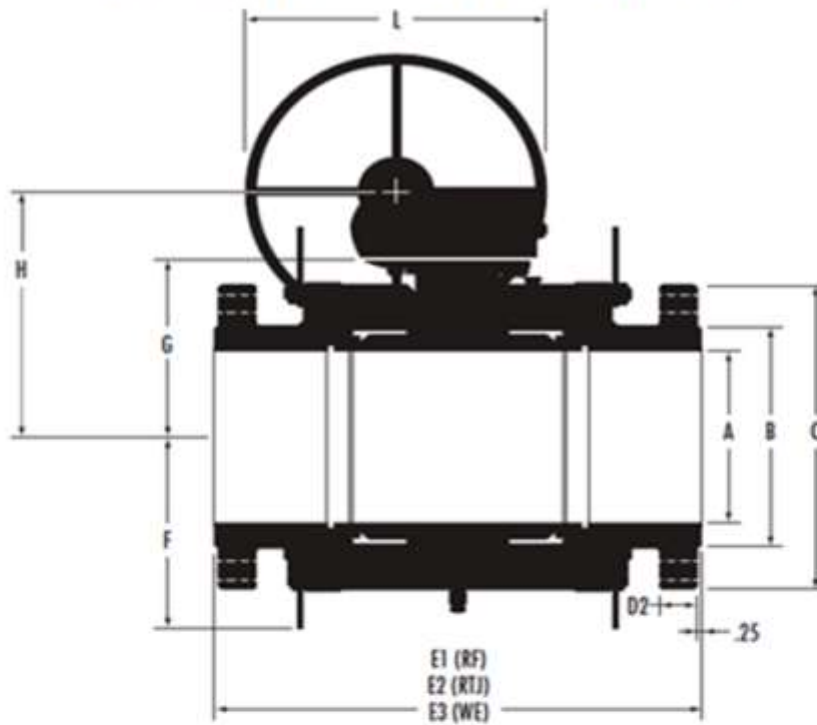

Class 900 14"FP-24"FP (in.)

Size	A	B	C	D2	E1-RF	E2-RTJ	E3-WE	F	G	H	L
14x14	12.75x12.75	16.25	25.25	3.38	40.50	40.88	40.50	18.61	16.76	23.34	30
16x14	14.75x12.75	18.50	27.75	3.50	44.50	44.88	44.50	20.63	16.76	23.34	30
16x16	14.75x14.75	18.50	27.75	3.50	44.50	44.88	44.50	20.63	18.87	25.77	30
18x16	16.75x14.75	21.00	31.00	4.00	48.00	48.50	48.00	23.39	18.87	25.77	30
18x18	16.75x16.75	21.00	31.00	4.00	48.00	48.50	48.00	23.39	24.91	31.81	30
20x18	18.63x16.75	23.00	33.75	4.25	52.00	52.50	52.00	24.30	24.91	31.81	30
20x20	18.63x18.63	23.00	33.75	4.25	52.00	52.50	52.00	24.30	26.18	33.08	30
24x20	22.50x18.63	27.25	41.00	5.50	61.00	61.75	61.00	21.70	24.20	28.90	30
24x24	22.50x22.50	27.25	41.00	5.50	61.00	61.75	61.00	23.80	29.80	30.90	30
30x30	28.11x28.11	33.75	48.50	5.88	69.29	70.16	65.35	30.94	31.42	*	*
36x36	33.74x33.74	40.25	57.50	6.75	80.71	81.89	74.80	36.38	36.14	*	*
40x40	37.56x37.56	45.75	59.50	7.75	85.83	*	82.68	39.88	39.65	*	*
44x44	41.26x41.26	50.00	64.88	8.44	93.70	*	88.58	41.26	45.28	*	*
48x48	45.00x45.00	54.50	70.25	9.19	96.46	*	93.70	47.64	47.72	*	*

Class 1500 14"FP-24"FP (in.)

Size	A	B	C	D2	E1-RF	E2-RTJ	E3-WE	F	G	H	L
14x14	12.50x12.50	16.25	29.50	5.25	49.50	50.25	49.50	20.60	18.83	25.73	30
16x14	14.25x12.50	18.50	32.50	5.75	54.50	55.38	54.50	22.27	18.83	25.73	30
16x16	14.25x14.25	18.50	32.50	5.75	54.50	55.38	54.50	22.27	20.50	27.40	30
18x16	16.75x14.25	21.00	36.00	6.38	60.50	61.38	60.50	23.39	20.50	27.40	30
18x18	16.75x16.75	21.00	36.00	6.38	60.50	61.38	60.50	23.39	24.91	31.81	30
20x18	18.63x16.75	23.00	38.75	7.00	65.50	66.38	65.50	23.39	24.96	31.81	30
20x20	18.63x18.63	23.00	38.75	7.00	65.50	66.38	65.50	21.70	27.50	28.90	30
24x20	22.50x18.63	27.25	46.00	8.00	80.50	81.63	80.50	21.70	27.50	28.90	30
24x24	22.50x22.50	27.25	46.00	8.00	80.50	81.63	80.50	23.80	33.70	30.90	30

MasterValve® General Terms and Conditions of Sale

By acceptance of the goods described herein, the Purchaser expressly acknowledges and agrees as follows:

1. Warranty: The warranty described below applies only to new or unused goods or goods reconditioned by MasterValve® (Seller). The Seller specifically disclaims any warranty for used goods or goods sold as is. For a period of one (1) year after date of purchase of any of the goods described herein, Seller warrants such goods shall remain free from failure due to defects in workmanship and materials incorporated therein by or for Seller provided such failure shall not have been caused or contributed to by improper usage, service or application, improper installation or maintenance, repairs, alterations, or modifications effected by or for the user, misuse, negligence or accident. In the event of failure for which Seller has assumed warranty obligations hereunder, and provided written notification of such failure shall be immediately given to Seller, it agrees to repair, or at its option, to replace the goods sold at its sold expense. Apart from the warranty and undertaking above set forth, or unless otherwise specifically consented to in writing by Seller, Seller assumes no obligation or liability for losses, expense or damages, direct or consequential, suffered or incurred as a result of any failure of, or defect in, the goods described herein, including but not limited to, such costs, expenses or damages as may result from the necessity to remove, replace, restore or transport the goods from any location or service in which they may be used, regardless of the cause of such failure or defect. This warranty extends only to the original Purchaser of the goods and is the only warranty made by Seller in connection therewith. There are no other warranties, express or implied, of any kind given with respect to the goods, their merchantability, fitness for any particular purpose or usage, or otherwise, nor is any person authorized to extend on behalf of Seller any form of warranty other than that above set forth. The goods described herein are not sold or distributed by Seller for personal, family or household purposes, nor are they normally suited for use as such.

2. Prices: Prices and other terms of sale where set forth in current price sheets are subject to change without notice. Stenographic or clerical errors are subject to correction.

3. Acceptance of Orders and Special Orders: All orders are subject to acceptance by Seller at its home office, Stafford, Texas, only. No assignment of the Purchaser's rights may be made without the written consent of the Seller. Orders for special materials are subject to cancellation only upon agreement to make payment for the work performed, material used, and a reasonable profit.

4. Terms, Payment and Partial Shipment: All accounts are payable net 30 days of invoice date. One percent (1%) per month interest charged on accounts after 30 days, or twelve percent (12%) annually. All accounts are payable in United States dollars, free of exchange, collection, or any other charges. If in the sole discretion of Seller, the financial condition of the Purchaser at any time so requires, Seller retains the right to require full or partial payment in advance, to set spending limits for credit accounts or to require other adequate assurances of financial responsibility. Seller reserves the right to make partial shipments from time to time and render invoices therefore, which shall be due and payable as provided in said invoices.

5. Freight Charges: Unless otherwise specifically noted, standard shipping charges (calculated by product weight, not including packaging) shall be added or be in addition to the price quoted and Purchaser agrees to pay the same to Seller.

6. Taxes: Unless otherwise specifically noted, the amount of any sales, use, occupancy, excise tax, or other tax, of any nature, federal, state, or local, for which Seller is legally liable, either initially or through failure of payment by Purchaser, shall be added or be in addition to the price quoted and Purchaser agrees to pay the same to Seller.

7. Unavoidable Conditions: Seller shall not be liable for failure to deliver or delays in delivery occasioned by causes beyond its control, including, without limitation, strikes, lockouts, fires, embargoes, war or other outbreaks of hostilities, acts of God, inability to obtain shipping space, machinery, breakdowns, delays of carriers or suppliers, and governmental acts or regulations.

8. Returns and Cancellations: No product may be returned without Seller's prior written consent. All goods returned are subject to a handling charge plus freight in both directions, restocking fees and charges for any required reconditioning, unless otherwise specified in writing by Seller. Overages, shortages and incorrect material claims must be made in writing within ten (10) days of receipt of goods. Cancellation of orders once placed with and accepted by Seller may be made only with its written consent.

9. No Waiver: Seller's failure to insist upon any of the terms, covenants, or conditions listed herein or to exercise any right hereunder shall not be construed as a waiver or relinquishment of the future performances of any such term, covenant or condition, or the future exercise of such right or a waiver or relinquishment of any other term, covenant or condition or the exercise of any other rights hereunder.

10. Drawings, Data and Confidential Information: The weights, dimensions, capacities, prices, performance ratings and other data included in catalogues, prospectuses, circulars, advertisements, illustrated matter and price lists constitute a guide. These data shall not be binding except to the extent that they are by reference expressly included in the purchase order. Any drawings or technical documents intended for use in the manufacture of machinery, equipment, plants, parts, or other material and any ancillary services associated therewith (Material), or a part thereof, and submitted to the Purchaser prior or subsequent to the formation of the purchase order, remain the exclusive property of the Seller. They shall not, without the Seller's consent, be utilized by the Purchaser or copied, reproduced, transmitted or communicated to an unauthorized third party, provided, however, that the said plans and documents shall be the property of the Purchaser if it is expressly so agreed in writing. Any drawings or technical documents intended for use in the construction of the Material or of part thereof and submitted to the Seller by the Purchaser prior or subsequent to the formation of the purchase order remain the exclusive property of the Purchaser. They shall not, without Purchaser's consent in writing, be utilized by the Seller or copied, reproduced, transmitted or communicated to an unauthorized third party.

11. Governing Law: This contract shall be governed by, construed and enforced in accordance with the laws of the State of Texas.

12. Totality of Agreement, Special Provisions, Modifications: This instrument constitutes the entire agreement of the parties with respect to all matters and things herein mentioned. Purchaser warrants, represents and agrees that it has inspected the goods and otherwise made inquiry and review, upon its own behalf, concerning the nature, characteristics and quality of the materials and workmanship incorporated therein at or prior to delivery, that it is fully contented and satisfied therewith and has independently determined that the goods are in all respects fit and usable for all purposes for which they are intended to be employed by Purchaser. It is expressly acknowledged and agreed by and between the parties that neither party has, nor is now, relying upon any collateral, prior or contemporaneous agreement, written or oral, assurance or assurances, representation or warranty, of any kind or nature as to or respecting the condition or capabilities of the goods and the other matters and things, rights and responsibilities herein fixed and described. No modification, waiver or discharge of any term or provision of this instrument shall be implied by law, nor shall any alteration, modification or acquittance of any such term or provision be effective for any purpose unless in writing signed by or upon behalf of the party charged therewith.

(1) Returns are accepted within 180 days of shipment. Restocking charges for returned standard materials is 15%. Cancellation of orders for standard materials prior to shipment may incur a 10% minimum cancellation charge. Cancellation of non-standard material may incur up to 100% cancellation charge depending on stage of work in progress. All material returned to MasterValve® must be accompanied by a prior written Returned Goods Authorization (RGA) form and freight must be prepaid. All material is subject to inspection and final disposition by MasterValve® quality department. A clean up and or re-certification charge may apply to any returned materials. Special items, buyouts, and modified products are non-returnable. (2) All products are subject to prior sales. (3) All sales are subject to MasterValve® standard Terms & Conditions.

13. Export Regulations: MasterValve® products can only be exported in accordance with U.S. Export Administration Regulations and other U.S. legal requirements. Diversion contrary to U.S. law is prohibited.

Master Valve USA Product Offering



Page 31



G Series Trunnion Mounted Ball Valve

Applications: upstream, midstream and downstream. Mid pressure to high pressure, pipeline and API 6D.



B Series Floating Ball Valve

Applications: petrochemical, refinery and chemical industries. Low to mid pressure; live-loaded stem seal for low emission environment.



API 6A Ball Valves

Applications: upstream high pressure; wellhead; subsea exploration; FPSO .

Tough Ball Valve for Toughest Flow



Master Valve USA INC

23555 Clay Road
Katy, Texas 77493
United States of America

Phone: +1 832-710-8078
Email: Inquiry@MasterValveUSA.com

Website: www.MasterValveUSA.com