

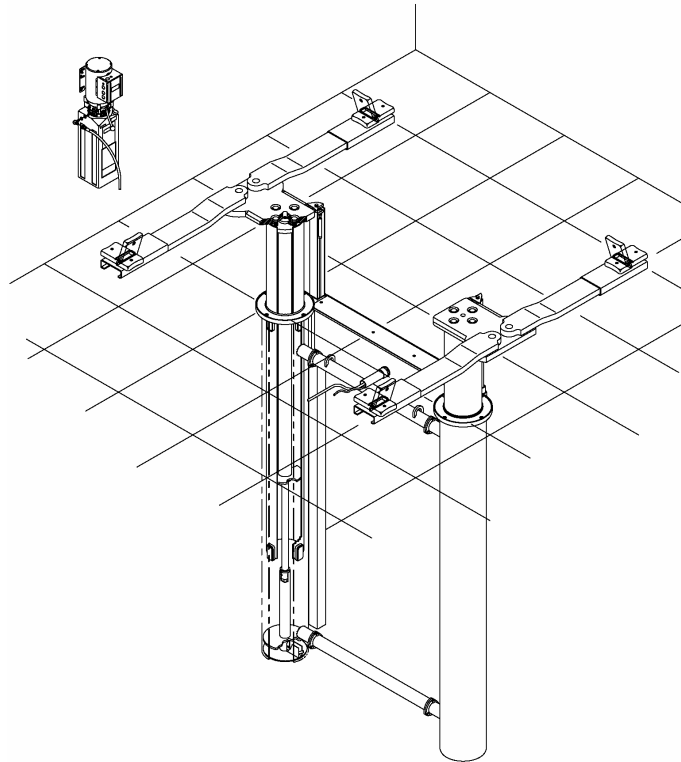

INSTALLATION and OPERATION MANUAL



10K 2 POST IN-GROUND 40HP210ES

**READ THIS INSTRUCTION MANUAL THOROUGHLY
BEFORE INSTALLING, OPERATING, SERVICING OR
MAINTAINING THE LIFT. SAVE THIS MANUAL.**



309 EXCHANGE AVENUE,
CONWAY, ARKANSAS, 72032
TEL: 501-450-1500 FAX: 501-450-1585

JUL 2008 REV. A 6-3667

TABLE OF CONTENTS

| | |
|---|-----------|
| 1.0 SAFETY AND OPERATING INSTRUCTIONS | 2 |
| 2.0 SAFETY WARNING DECALS..... | 4 |
| 3.0 GENERAL SPECIFICATIONS | 5 |
| 4.0 SHIPPING CONTENTS..... | 5 |
| 5.0 TOOLS REQUIRED FOR INSTALLATION..... | 6 |
| 6.0 BAY LAYOUT..... | 7 |
| 7.0 EXCAVATION | 10 |
| 8.0 ASSEMBLY INSTRUCTIONS | 12 |
| 9.0 INSTALLATION INSTRUCTIONS..... | 15 |
| 9.1 POWER PACK INSTALLATION..... | 16 |
| 9.2 HYDRALLIC AND AIR CONNECTIONS..... | 16 |
| 10.0 BLEEDING PROCEDURES..... | 17 |
| 11.0 FINAL CHECK OF ASSEMBLED LIFT | 18 |
| 12.0 OPERATING INSTRUCTIONS | 19 |
| 13.0 AUTOMOTIVE LIFT SAFETY TIPS | 21 |
| 14.0 TROUBLE SHOOTING GUIDE | 22 |
| 15.0 REGULAR MAINTENANCE | 23 |
| 16.0 LIFT ASSEMBLY | 24 |
| 16.1 LIFT PARTS LIST | 25 |
| 17.0 POWER PACK ASSEMBLY | 27 |
| 17.1 POWER PACK PARTS LIST | 28 |
| 18.0 AVAILABLE ACCESSORIES | 30 |

This lift requires at least 2 persons for assembly / installation.

1.0 SAFETY AND OPERATING INSTRUCTIONS

When using this lift, basic safety precautions should always be followed, including the following:



1. Thoroughly read all instructions in this manual and on the lift before installing, operating, servicing or maintaining the lift.
2. Inspect lift daily. Do not operate if it malfunctions or problems have been encountered.
3. Never attempt to overload the lift. The manufacturer's rated capacity is shown on the identification label. Do not override the operating controls or the warranty will be void.
4. Before driving vehicles into the lift area, position the arms to the drive-through position to ensure unobstructed clearance. Do not hit or run over arms as this could damage the lift and/or vehicle.
5. Only trained and authorized personnel should operate the lift. Do not allow customers or bystanders to operate the lift or be in the lift area.
6. Position the lift support pads to contact the vehicle manufacturer's recommended lifting points. Raise the lift until the pads contact the vehicle. Check pads for secure contact with the vehicle. Check all arm restraints and ensure they are properly engaged. Raise the lift to the desired working height.
7. Some pickup trucks may require an optional truck adapter to clear running boards or other accessories.
8. **NOTE:** Always use all 4 arms to raise and support vehicle.



9. **Caution! Never work under the lift unless the mechanical safety locks are engaged.**
10. Note that the removal or installation of some vehicle parts may cause a critical load shift in the center of gravity and may cause the vehicle to become unstable. Refer to the vehicle manufacturer's service manual for recommended procedures.
11. Always keep the lift area free of obstruction and debris. Grease and oil spills should always be cleaned up immediately.
12. Never raise vehicle with passengers inside.
13. Before lowering check area for any obstructions.
14. Before removing the vehicle from the lift area, position the arms to the drive-thru position to prevent damage to the lift and or vehicle.
15. **Do not remove hydraulic fittings while under pressure.**

SAVE THESE INSTRUCTIONS

For additional safety instructions regarding lifting, lift types, warning labels, preparing to lift, vehicle spotting, vehicle lifting, maintaining load stability, emergency procedures, vehicle lowering, lift limitations, lift maintenance, good shop practices, installation, operator training and owner/employer responsibilities, please refer to “Lifting It Right” (ALI/SM) and “Safety Tips” (ALI/ST).

For additional instruction on general requirements for lift operation, please refer to “Automotive Lift-Safety Requirements For Operation, Inspection and Maintenance” (ANSI/ALI ALOIM).

Installation shall be performed in accordance with ANSO/ALI ALIS, Safety Requirements for Installation and Service of Automotive Lifts.



ATTENTION! This lift is intended for indoor installation only. It is prohibited to install this product outdoors. Operating environment temperature range should be 41 – 104 °F (5 – 40 °C). Failure to adhere will result in decertification, loss of warranty, and possible damage to the equipment.

+ 070126-Quadra-WLSIA01

SAFETY INSTRUCTIONS

If attachments, accessories or configuration modifying components that are located in the

load path, affect operation of the lift, affect the lift electrical listing or affect intended vehicle accommodation are used on this lift and, if they are not certified for use on this lift, then the certification of this lift shall become null and void. Contact the participant for information pertaining to certified attachments, accessories or configuration modifying components.

www.autolift.org

©2007 by ALI, Inc.

ALI / WLSIA01

2.0 SAFETY WARNING DECALS

Be sure the operator is aware and understands all safety warning labels and follows them accordingly.

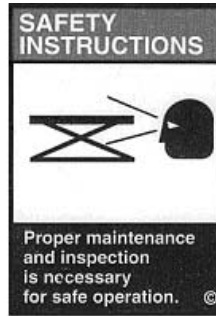

3.0 GENERAL SPECIFICATIONS

| | | |
|--|-----------------------------|---------|
| Capacity: | 10000 lbs. | 4536 kg |
| Overall Width: | 88" | 2235 mm |
| Height to Lowered Lift Pads | 4 ½" | 114 mm |
| Height to Lift Pad (3" Adapter): | 7" | 178 mm |
| Height to Lift Pad (6" Adapter): | 9 ½" | 241 mm |
| Height to Lift Adapter (8 7/8" Truck Adapter): | 12 ¼" | 311 mm |
| Arm Extended Length: | 41 ½" | 1054 mm |
| Arm Retracted Length: | 28 ⅛" | 714 mm |
| Maximum Lifting Height (No Adapter): | 73 ¼" | 1861 mm |
| Maximum Lifting Height (8 7/8" Truck Adapter): | 82 1/8" | 2086 mm |
| Lifting Time (approximately): | 61 sec. | |
| Lowering Time (approximately): | 126 sec. | |
| Power Requirements: | 230 Volts AC, 1 Ph., 60 Hz. | |
| Air Requirements: | 90 – 120 psi Shop Air | |

4.0 SHIPPING CONTENTS

Overall Weight: 2300lb / 1043kg

2 - Cylinders bolted together (93" long) with locking legs, attaching bolts, & stainless steel cables (Cables measure 5/16" x 137 1/2" with adjusting allen bolts on ends)

2 - Lifting Superstructures

1 - Cable Pulley Box with lid

1 - 1/2" I.D. x 21' Hydraulic Hose (lift and pump)

1 - 1/4" O. D. x 21' Nylon Airline (run from air cylinder to push button on pump air valve)

1 - Wheel spotting plate

1 - Plastic Bag containing (located inside cable pulley box):

12 - 7/16" x 1-1/4" Bolts and Nuts (for attaching spreader bars).

4 - Screws and Anchors (for wheel spotting plate)

1 - 1-1/2" PVC through hull fitting with 'O' ring

1 - 1/4" I.D. Hydraulic Hose Tee

1 - Installation Booklet ("Lifting It Right Tips" and Warranty Card)

4 - 1/4" x 3" Anchor Bolts (for mounting pump to wall)

2 - 1/4" x 1" Bolts & Nuts (for attaching cable box to cylinders)

4 - 1/2" x 1-3/4" Flat Head Allen

1 Pumping Unit

With air switch attached Single Phase / 230 Volts with 6-1/2" x 24" tank and 4-poster gears.

5.0 TOOLS REQUIRED FOR INSTALLATION

- Rubber mallet
- Open wrench for pulley box lid 7/16"
- Allen wrench 5/16"
- Allen wrench 1/4"
- Allen wrench for cable adjustment (900 bend) 3/8"
- Wrench 3/4"
- Wrench 7/16"
- Wrench 11/16"
- Vice grips for cable adjustment reg.
- Ratchet 6" extension and 3/4" deep socket for pulley assembly nut reg.
- Wire cutters for cutting airlines 3/4"
- Wrench for hydraulic fittings reg.
- Pliers
- Socket for attaching the lifting superstructures to the pistons 1-7/16"
- Work gloves
- 3' pry bar for manipulating cylinders
- Level 6'
- Tape measure
- Set of screwdrivers
- Impact gun
- Torque gun
- Crain for lifting and installing cylinders
- Funnel
- Hammer drill or similar, 1/4" and 1/2" concrete drill bits
- Caulking gun

Some of the supplies required:

- The necessary fittings for running shop air to air lift lock release button - 1/8" pipe, female
- 3-1/2 gallons ISO-32 Hydraulic oil
- 1 tube of waterproof silicone sealer 20' by 1-1/2" schedule #40 PVC pipe and 1-1/2" PVC electrical sweep
- Spray can of silicone lubricant

6.0 BAY LAYOUT

1. Make certain there is at least 70" between the lowest ceiling obstruction and the roofline of the highest vehicle to be raised. 12 ft. of ceiling height is sufficient for passenger cars.
2. A minimum of 12 ft. of stall space is required from both front and rear of lift center to nearest obstruction. (See Figure 1 & 2).
3. 6 ft. is the recommended dimension, plus desired work area, between the lift center and side wall or nearest obstruction.

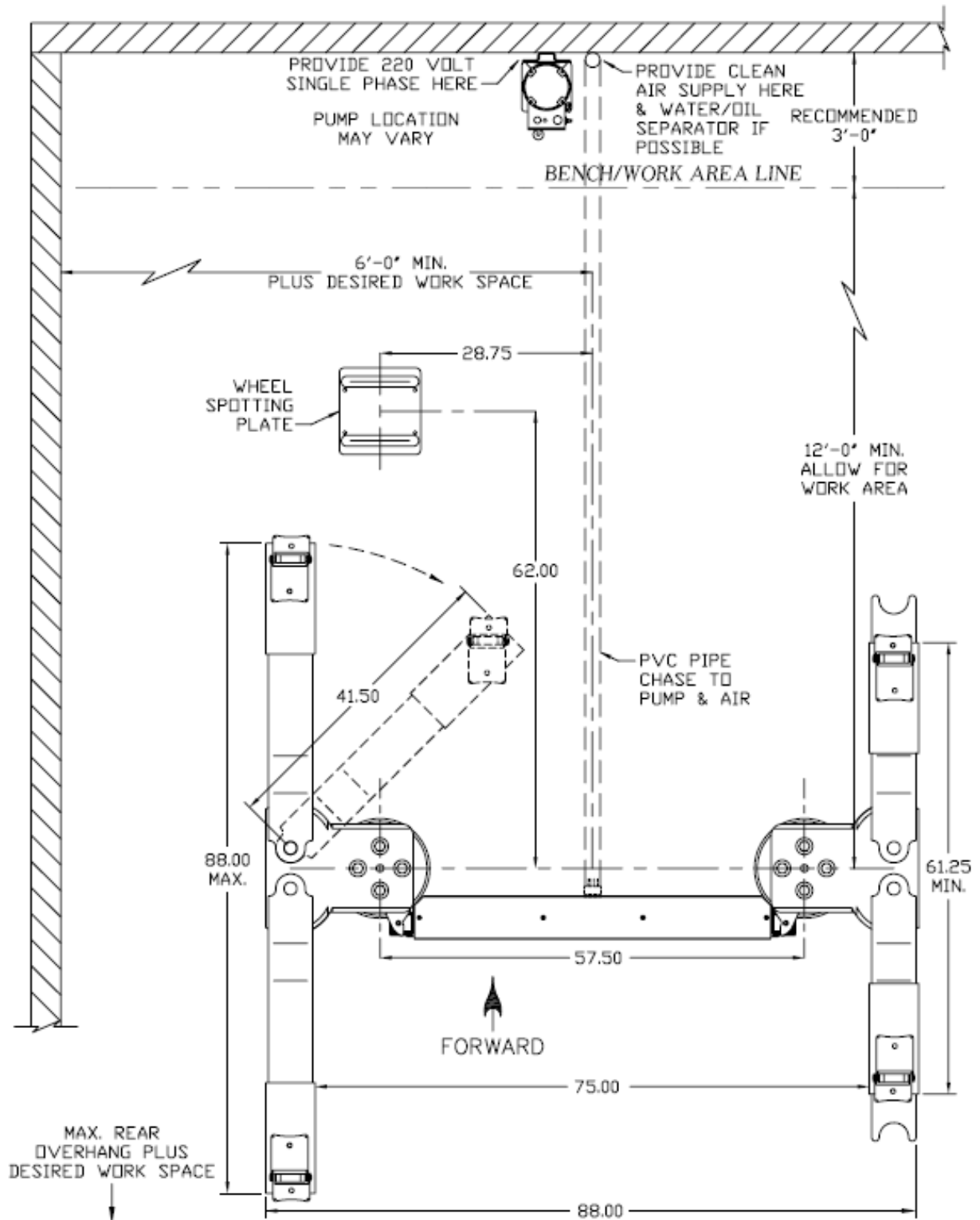

Figure 1 - Bay Layout (Option A)

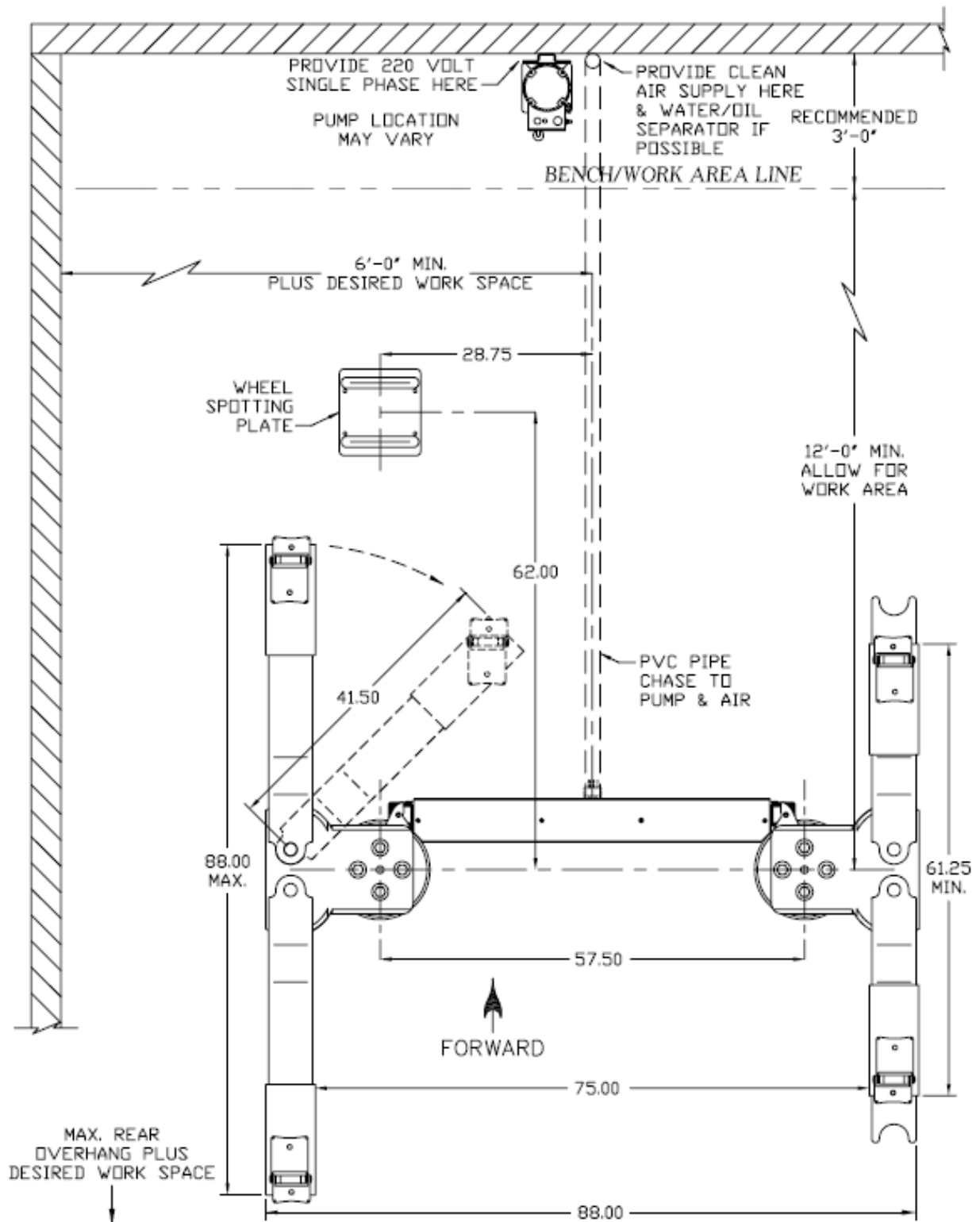

Figure 2 - Bay Layout (Option B)

7.0 EXCAVATION

1. Dig a hole to accommodate the lifting unit to a minimum dimension of 24"Lx 84"W x 100"D. (See Figure 3).
2. Dig a 9" deep trench (pipe chase for hydraulic and air lines) from the cylinder pulley box center fitting to the location you have selected to mount the pump and controls.

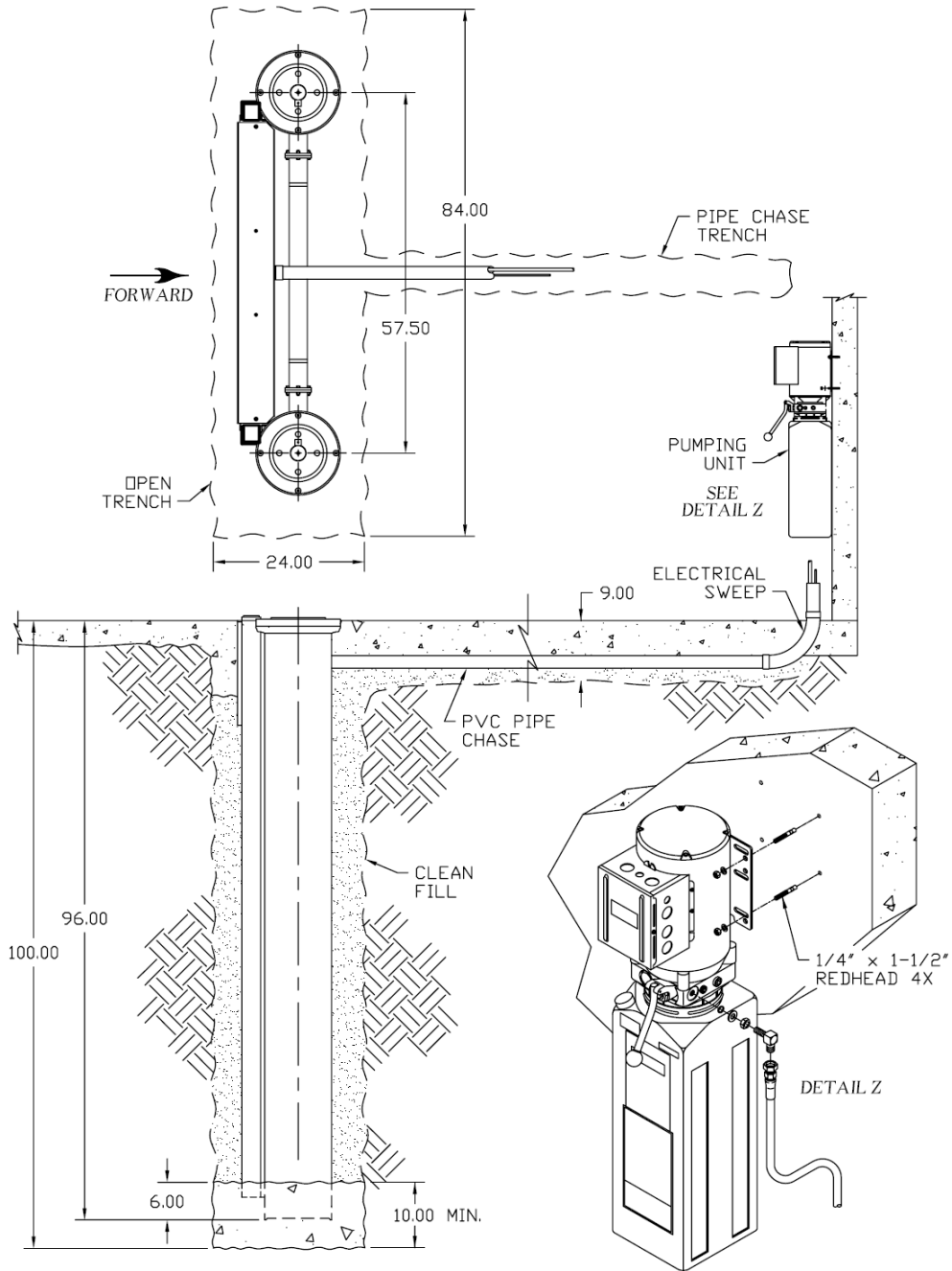

Figure 3 - Plan and Excavation

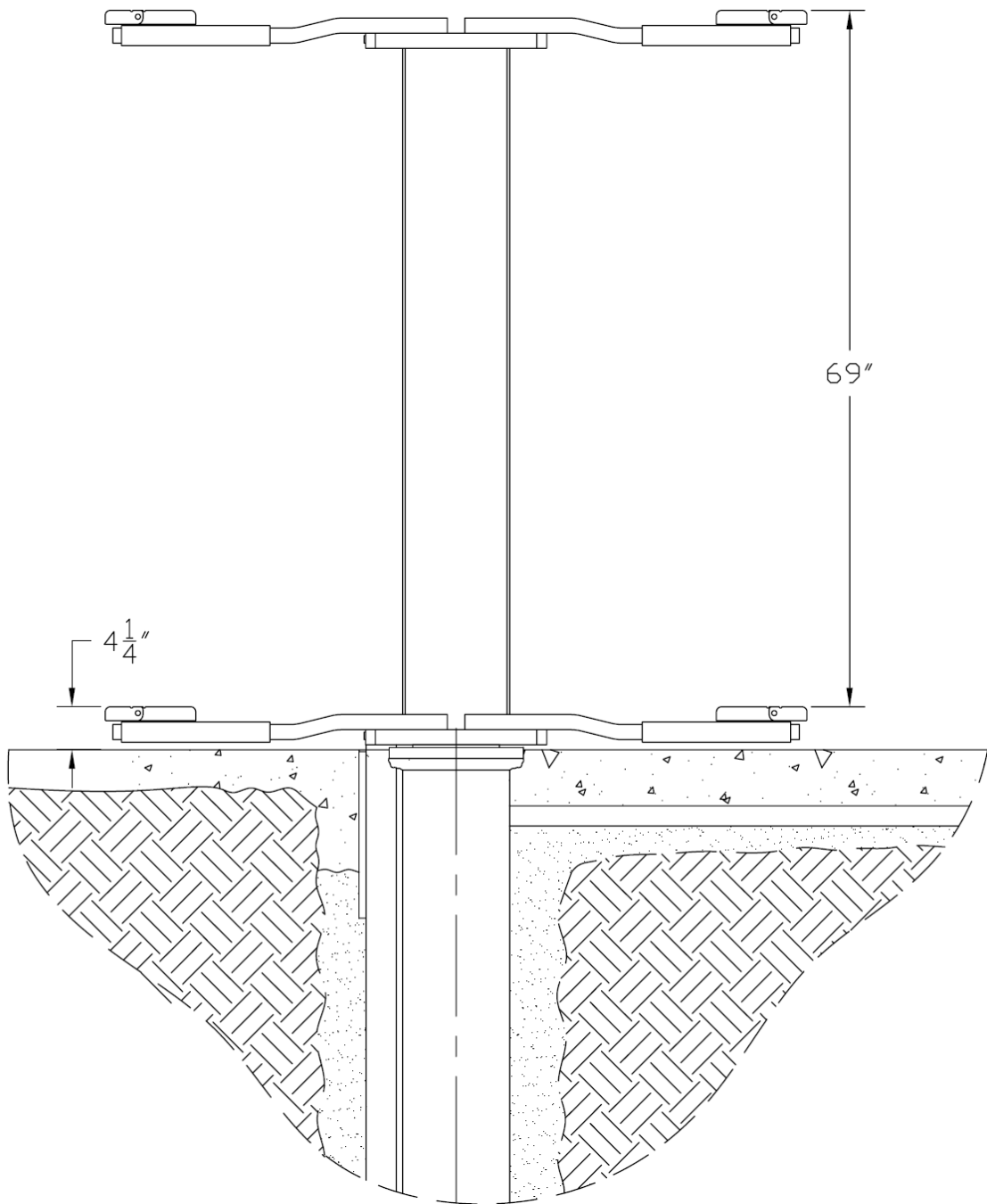
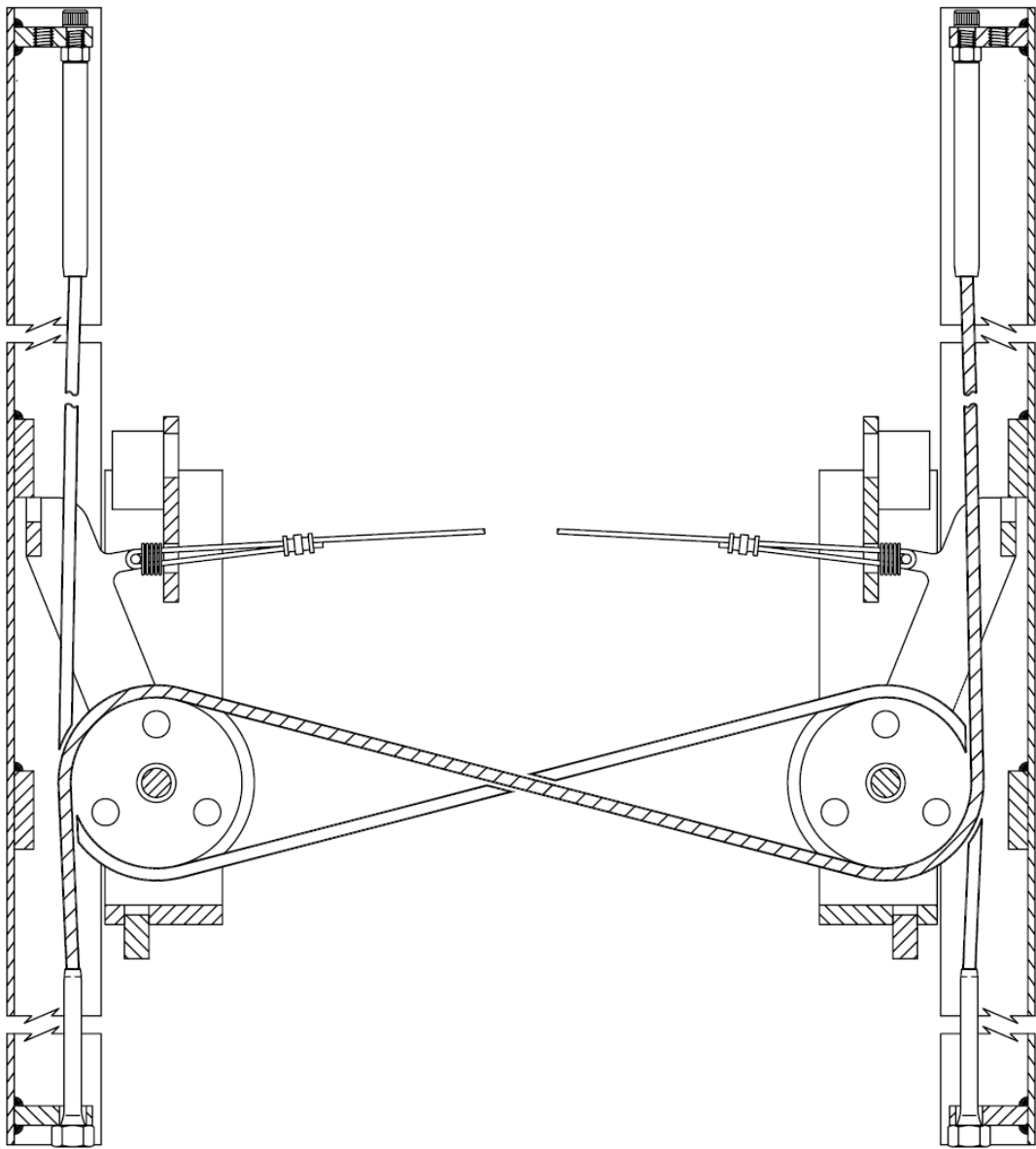

Figure 4 – Elevation

8.0 ASSEMBLY INSTRUCTIONS

1. Adjusting Cable Tension: With the locking legs extended approximately 8 inches, tighten both the left and right side cable bolts equally. (See Figure 5). To check tension, grab cable in center and pull up on it with about 30 pounds of force. Cable should deflect about 1-3/4" to 2". This would be the proper cable tension. To adjust the cables for equal rise, measure exactly the amount of locking leg that is extended. If for instance, the left side locking leg is extended further than the right, loosen the right cable bolt and tighten the left cable bolt. Continue this procedure until both locking legs are extended equally. NOTE: When adjusting cables, hold the fitting on the end of the cable with vice grips to prevent turning.
2. Attach the 1/2" O. D. hydraulic lines to the tee fitting provided so that it will be next to the PVC through hull fitting (halfway between the pulleys). Tape the open ends to prevent any foreign objects from entering during installation. (See Figure 6).



LEFT

RIGHT

Figure 5 - Cable Routing

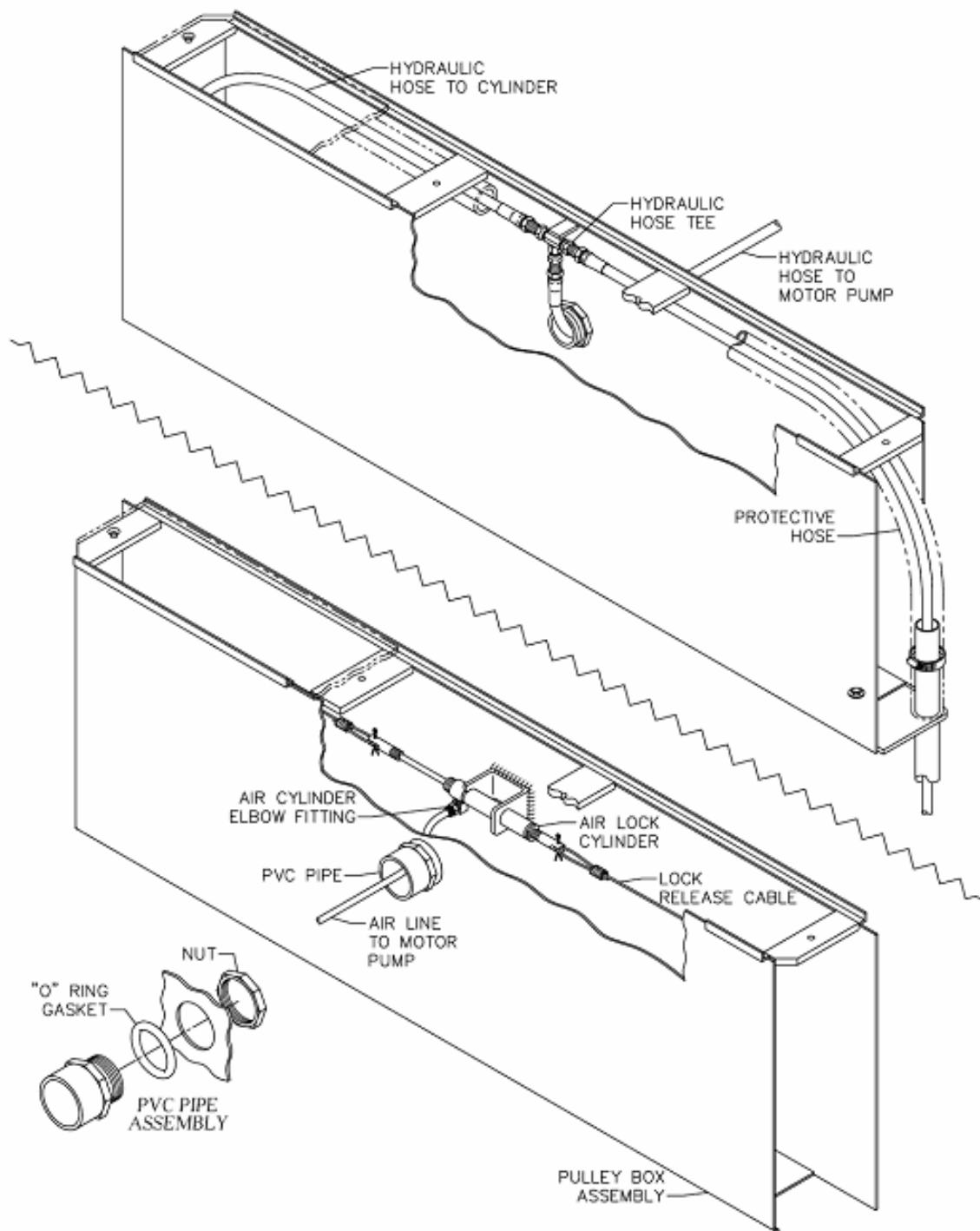

Figure 6 - Hydraulic and Air Connections

9.0 INSTALLATION INSTRUCTIONS

Before Installing:

- After unpacking the lift, check shipping list to ensure that you have all required parts.
 - Check unit carefully for shipping damage.
 - Handle unit with care. Dropping could cause internal damage.
 - Store unit indoors or under cover to prevent rusting or pitting from condensation.
 - **DO NOT ATTEMPT TO RAISE THE LIFT WITHOUT SUPERSTRUCTURES ATTACHED.**
1. Attach a lifting chain to the upper spreader bar and lower cylinder assembly into excavation, making sure the PVC through hull fitting is facing the front of the bay where pumping unit will be installed.
 2. Secure cylinders to a finished height of 1/8" above finished floor grade. Wooden 6" x 6" planks and 1/2" threaded rod help achieve proper positioning. NOTE: Slope concrete away from lift in all directions.
 3. Place a spirit level across the top of the pistons (not the cylinder flanges) in two directions and adjust until pistons are plumb. Use a 6 ft. level from one piston to the other to make sure they are level with each other. Correct by adjusting as necessary.
 4. Pour concrete around bases of both cylinders to a minimum of 10" deep and 6" up the cylinders. (See Figure 3). Allow 24 hours for concrete to cure.
 5. Backfill with a clean dry washed sand fill to a level of 24" below floor grade. Firmly tamp and check for plumbness frequently while backfilling.
 6. In the 9" deep trench from the pulley box to the wall where the pump lines will be installed, use only 1-1/2" PVC electrical sweep as it makes its turn up the wall to the pumping unit (leave the PVC sweep at least 6" above the floor grade to prevent water from entering the box).
 7. Connect the PCV sweep fitting to pulley box assembly. NOTE: Make sure to place an "O" ring gasket between the PVC fitting and the outer surface of the pulley box assembly. Fully tighten the nut to prevent leakage upon pouring of the concrete. (See Figure 5).
 8. Complete backfill to a level of 9" below floor grade.
 9. After rechecking plumbness in all directions, pour and finish concrete making certain that cylinder flanges are 1/8" above finished grade. Note: It is recommended to slightly taper concrete up the cylinder to prevent any standing water around cylinder flange.
 10. Install wheel-spotting dish in proper location. (See Figure 1 & 2).
 11. After allowing 48 hours for concrete to cure, attach lifting structures to pistons and equalizer struts.

9.1 POWER PACK INSTALLATION

1. **POWER UNIT REQUIREMENTS:** 230 volts, single-phase power. Use separate circuit for each unit and protect each unit with 30 AMP time delay fuse or circuit breaker.
2. Have a certified electrician wire your pump to the pump motor. The electrical diagram is provided. (See Figure 7).
3. Attach pumping unit (tank down) to location selected in front of lift. The connecting fittings should be at least 36" off the floor.
4. Install the hydraulic lines and air lines through the 1-1/2" PVC.
5. **FILLING PUMPING UNIT:** Fill pumping unit with AW-32 hydraulic oil, I.S.O. 32 with anti-rust and anti foam agents (approx. 14 quarts). **DO NOT USE TRANSMISSION FLUID.**

9.2 HYDRALLIC AND AIR CONNECTIONS

1. Install the 1/2" O. D. x 21' hydraulic line and the 1/4" O. D. x 21' airline from the pump to the pulley box through the 1-1/2" PVC sweep.
2. Connect the hydraulic line to the tee and the air line to the air cylinder elbow fitting, both located inside the pulley box.
3. Connect the other ends to the pumping unit hydraulic fitting and air lift lock release button (safety release valve) making sure that all fittings are properly tightened. (See Figure 5).
4. Run an air supply line from shop air to the 1/8" pipe fitting at the base of the air lock release button on pump.

10.0 BLEEDING PROCEDURES

After filling the unit, there will still be trapped air in the system. You must bleed the system as instructed for proper operation of lift.

1. To bleed the air from the hydraulic system, raise the internal cylinders approximately 12", using the pumping unit. (LIFTING STRUCTURES MUST BE OFF).
2. Loosen the 1/4" hex head bolt at the end of each internal cylinder, using a 7/16" socket wrench. (DO NOT ALLOW THE INTERNAL CYLINDER TO ROTATE WHILE LOOSENING OR TIGHTENING THIS PLUG).
3. Step down on the end of each cylinder to force the trapped air from the system. Repeat if necessary to remove all air till oil begins to flow from the plug.
4. Once this is completed make sure to properly apply sealant to these plugs and tighten to prevent leaking.
5. Open lowering valve on pump. Step on the ends of these cylinders to force them back down.
6. Add oil till recommended level in the tank is met.
7. Attach the arm structures. Torque 7/8" bolster bolts to 250 lbf-ft.
8. Raise lift fully and wipe pistons down with a light coat of silicone lubricant or WD-40.
9. Lower the lift and record oil level in the pumping unit.
10. Pressure check bleed-plugs by inspecting them through the hole in the center of the lifting structures.
11. Check the hydraulic tee and the fitting on the pump for any leaks, tighten if necessary.

CAUTION!

DO NOT FULLY RAISE LIFT WITHOUT SUPERSTRUCTURES ATTACHED. THE PISTONS WILL COME OUT OF CASINGS AND MAY BE DIFFICULT TO LOWER WITHOUT THE WEIGHT OF THE SUPERSTRUCTURE ON THEM.

WHEN BLEEDING CYLINDERS, DO NOT ALLOW INNER CYLINDERS TO ROTATE. THIS MAY CAUSE HOSE KINK.

KEEP ALL LIQUIDS AWAY FROM LIFT (water, cleaners, acids, etc). ANY LIQUID WHICH GETS INSIDE THE LIFTING UNIT WILL CAUSE INTERNAL DAMAGE AND WILL NOT BE COVERED UNDER WHEELTRONIC'S WARRANTY.

11.0 FINAL CHECK OF ASSEMBLED LIFT

1. Check for air and hydraulic leaks. ____
2. Ensure all safety lock mechanisms are working correctly. ____
3. Check all fasteners, tighten if necessary. ____
4. Operate lift to full stroke then lower to ground while checking for proper functionality. ____
5. Ensure Customer Care Kit is complete and given to operator. ____
 - a. Operation Manual ____
 - b. ANSI / ALI Lift It Right Manual ____
 - c. ANSI / ALI Safety Tip Card ____
 - d. ANSI / ALI ALIS Safety Requirements for Installation and Service of Automotive Lifts ____
 - e. ANSI / ALI Quick Reference Guide ____
6. Train end user on operation of the lift. ____

12.0 OPERATING INSTRUCTIONS

It is the responsibility of the Owner/Operator to be thoroughly familiar with the Operation, Inspection, and Maintenance of this lift.

Before Lifting: DO NOT RAISE CYLINDERS WITHOUT SUPERSTRUCTURES ATTACHED.

IMPORTANT:

When lifting the vehicle, the flip pad adapters must be positioned as shown in Figures 7 and 8.

- **ALL FLIP PADS MUST FACE OPPOSITE DIRECTIONS**
 - **FLIP PADS CANNOT POINT IN THE SAME DIRECTION**
1. Rotate arms to provide tire clearance.
 2. Center vehicle left and right over lift with wheel in proper spotting plate according to vehicle size.
 3. Position adapter pads at vehicle manufacturer's approved lifting points.
 4. If adapters are raised, face front and rear in opposite directions. Make sure the height adapters are positioned in a proper designated location. (See Figures 7 – 9).



Figure 7 - CORRECT positioning of flip pad adapters



Figure 8 - CORRECT positioning of flip pad adapters



Figure 9 - INCORRECT positioning of flip pad adapters

Lifting:

1. Push in on “pump electrical switch” and raise lift until adapters contact vehicle.
2. Check to make certain that all height adapters are making full and proper contact and are stable.
3. Raise lift approximately 18” and check stability by rocking vehicle front to rear.
4. While raising the lift, the air lift safety locks will engage at different stages. Raise lift to desired height and lower onto lift locks. Avoid sporadic starting and stopping of pump motor if possible.
5. To prevent pump motor damage, always lower load onto safety locks when restarting motor in mid-stroke.

Lowering:

1. Make sure area under vehicle is clear of obstacles.
2. Raise lift slightly.
3. To disengage air-operated lift safety locks, push air lock release button in while pushing on handle to lower the lift.
4. Lower the lift until lift superstructures make full contact with floor.
5. Rotate arms to provide tire clearance.
6. Make certain adapters are in the flat position before removing vehicle.
NOTE: Remove 8-7/8” Truck Height Adapters, if used.

13.0 AUTOMOTIVE LIFT SAFETY TIPS

Please post these safety tips in a place where the operator will be constantly reminded of their importance. ALWAYS REFER TO THE LIFT MANUFACTURER'S SPECIFIC SAFETY OPERATION AND MAINTENANCE INSTRUCTIONS

1. When positioning vehicle, do not hit or run over lift arms, adapters or axle supports.
2. Operating valves, switches and locking devices are designed for maximum safety. Never attempt to block open or override them.
3. Never overload your lift beyond manufacturer's stated capacity.
4. Do not allow customers or bystanders to operate lift or to be in lift area during operation. Never raise vehicles with anyone inside.
5. Be sure work area around lift is clear, free of obstructions, debris, grease and oil.
6. Never lift a vehicle unless arm restraints are locked.
7. Never attempt to operate a lift if it appears to be malfunctioning or if broken/damaged parts are evident.
8. Load lift carefully. Check to be sure adapter or axle supports are in secure contact with vehicle, PER MANUFACTURER'S INSTRUCTIONS, before raising to desired working height. NEVER LIFT VEHICLE BY SUSPENSION PARTS.
9. Release locking devices as per manufacturer's instructions before attempting to lower lift.
10. Before removing vehicle from lift area, position arms, adapters or axle supports to assure that vehicle or lift will not be damaged.

14.0 TROUBLE SHOOTING GUIDE

Possible Cause & Solution

1. Pump motor does not run

- A. Breaker tripped or fuse blown. Check breaker and incoming power.
- B. Motor thermal overload tripped. Wait for overload to cool.
- C. Check thermal overload in starter box (3 phase only). Push reset.
- D. Faulty wiring connections. Check wiring diagram.

2. Motor runs but the lift will not rise

- A. A foreign object is lodged under check valve. As you are running the pumping unit, push or hold a load in and out several times on the lowering valve. This should release any foreign objects trapped in the pump.
- B. Remove check valve. Clean the ball and seat, and replace if necessary.
- C. Oil level low. Check reservoir. With lift in the down position, the pump reservoir should be full.

3. Motor runs but the lift picks up partial load only

- A. Lift is overloaded. Check lifts capacity and weight of vehicle.
- B. Relief valve setting is too low. Remove hex head plug in the center of the pump and adjust pressure setting valve.

4. Oil blows out breather

- A. Oil reservoir overfilled.
- B. Lift lowered too quickly while under heavy load.

5. Lift makes groaning sound when rising

Bleed cylinder manually. Trapped air can cause groaning noise when rising or lowering lift.

6. Lift rises unevenly.

- A. Cables are not properly adjusted or tightened.
- B. Use lightweight oil in the pump. AW-32 hydraulic oil I.S.O. 32 with antifoam and antirust agents.

15.0 REGULAR MAINTENANCE

User should check oil level at least once every two weeks. A change in oil level would be an indication of oil leaks in the lines or in the hydraulic cylinder and should be checked.

1. Inspect all superstructure fasteners. Tighten if necessary.
2. Inspect cables for fraying. If fraying is evident, DO NOT USE THE LIFT. Replace cables.
3. Grease swivel arm rub bars.
4. Inspect arms for overload drooping from stretched or loosened arm bolts. Have loose bolts tightened and stretched bolts replaced.
5. Inspect the height adapters for damage and replace if necessary.
6. Use a spray can of silicon lubricant on piston surfaces. **NOTE:** Clean and wipe down pistons with a clean dry cloth before applying the silicon lubricant.

16.0 LIFT ASSEMBLY

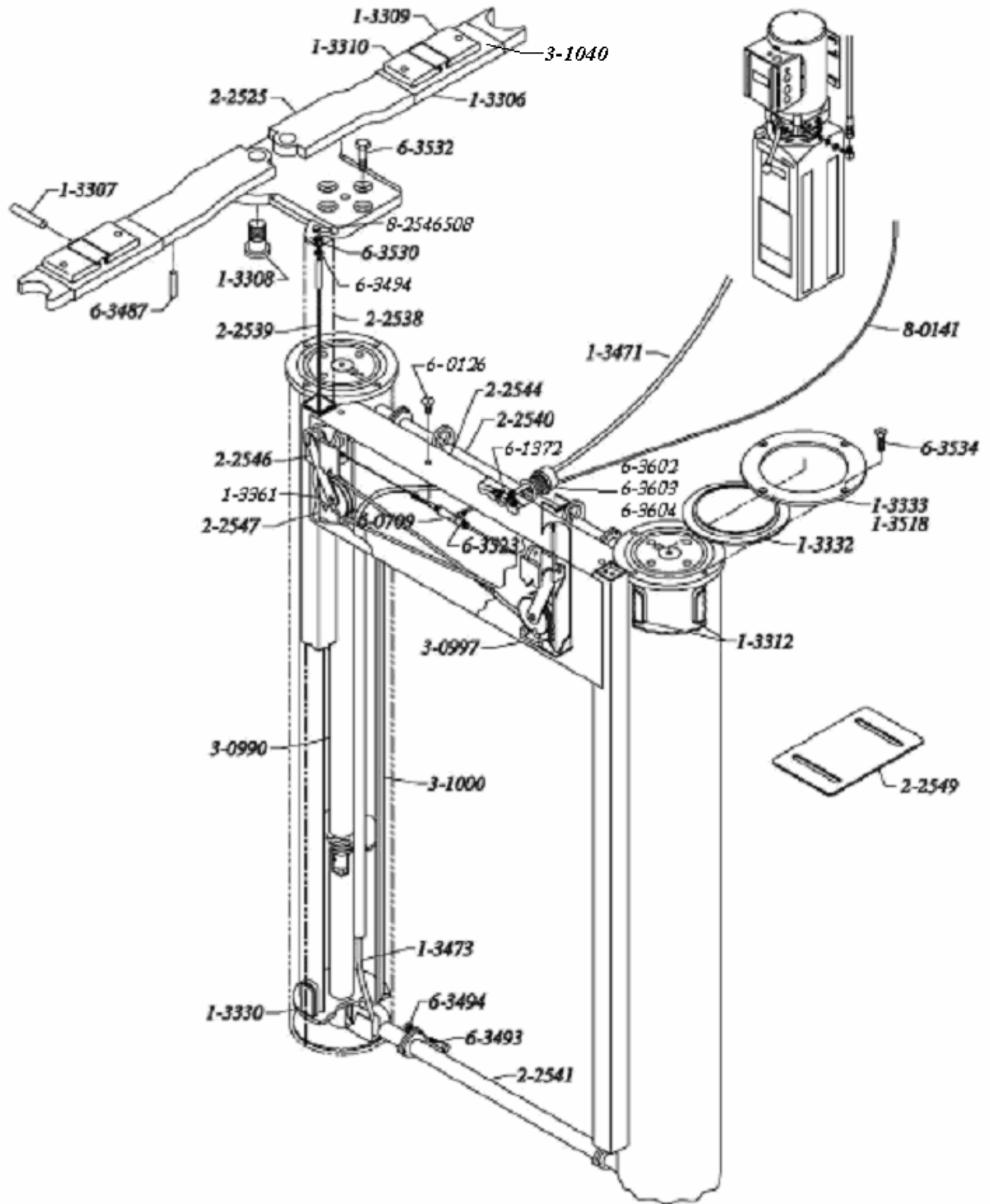

16.1 LIFT PARTS LIST

| Part No. | QTY. | Description |
|-----------|------|------------------------------------|
| 2-2525 | 4 | Swing Arm |
| 1-3306 | 4 | Sleeve |
| 1-3307 | 4 | Adapter Wing Pin |
| 1-3309 | 4 | High Flip Up Adapter Wing |
| 1-3310 | 4 | Low Flip Up Adapter Wing |
| 3-1040 | 4 | Flip Pad Assembly |
| 6-0752 | 8 | Circlip ½" |
| 6-3487 | 4 | Roll Pin 3/8" x 1" |
| 1-3308 | 4 | Arm Bolt |
| 2-2539 | 2 | Equalizing Cable |
| 6-3530 | 2 | 7/16-14 Socket Head Cap Screw |
| 6-3494 | 2 | Hex. Nut 7/16" |
| 6-3532 | 8 | 7/8" x 3" Hex HD Bolt G8 |
| 8-2546508 | 2 | HCS 1/2-13" x 2" GR8 PLTD |
| 2-2538 | 2 | Locking Leg Weldment |
| 2-2546 | 2 | Trigger Weldment |
| 2-2547 | 2 | Housing Weldment |
| 1-3361 | 2 | Pulley Assembly |
| 30990 | 2 | Hydraulic Cylinder – HP210ES |
| 1-3330 | 8 | Piston Block Holder |
| 2-2541 | 1 | Bottom Spacer Pipe Weldment |
| 6-3493 | 12 | Hex. Bolt 7/16-14" x 1-1/4"L |
| 6-3494 | 12 | Hex. Nut 7/16" |
| 1-3473 | 2 | Hyd. Hose Cylinder 2P Inground |
| 3-1000 | 2 | Piston Weldment |
| 3-0997 | 1 | Pulley Box Weldment |
| 6-3523 | 1 | Air Lock Cylinder |
| 6-0709 | 1 | Swl. Elbow, 14" Poly x 1/8" NPT |
| 6-0126 | 4 | Hex. Bolt, ¼" UNC x 1/2", G5 |
| 6-3806 | 1 | Bulkhead "T" 3/8" JIC Fitting |
| 2-2544 | 1 | Top Cover |
| 2-2540 | 1 | Top Spacer Pipe Weldment |
| 1-3471 | 1 | Hyd. Hose Pump 2P/Sing Inground |
| 6-3602 | 1 | Lock Nut 1-1/2" |
| 6-3603 | 1 | "O" Ring |
| 6-3604 | 1 | PVC Male Adapter 1-1/2" |
| 8-0141 | 1 | Tube, Poly., ¼" Dia. x 0.038" Wall |
| 1-3333 | 1 | Retainer Ring – Left 2P Inground |
| 1-3332 | 2 | 8 3/8" ID Wiper |
| 1-3518 | 1 | Retainer Ring – Right 2P Inground |
| 1-3312 | 8 | Casing Bearing Block |
| 2-2549 | 1 | Wheelstop Spotting Plate |

3-1026* 1 Pump Stand Bolt Down Standard

* Not shown in figure.

17.0 POWER PACK ASSEMBLY

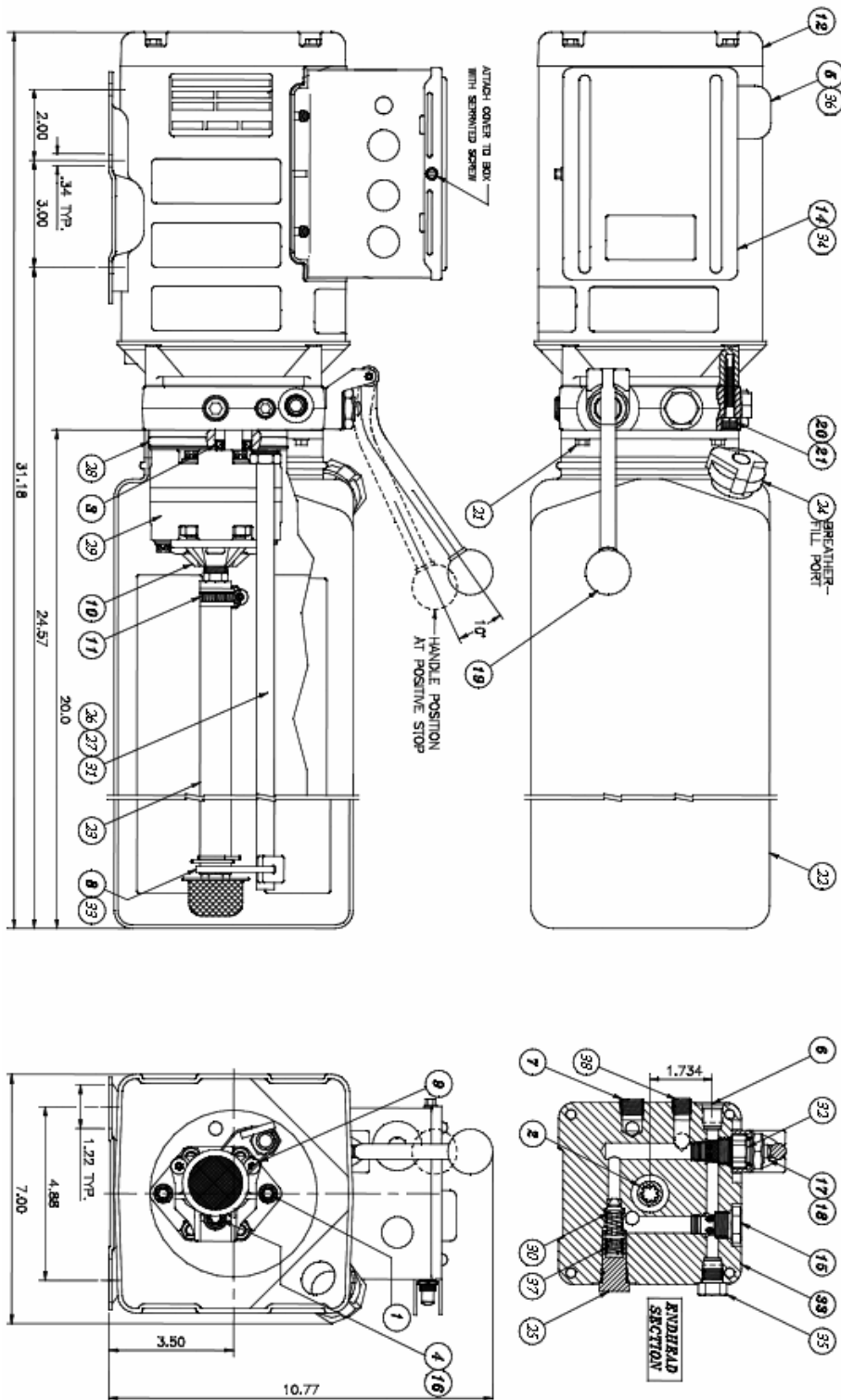

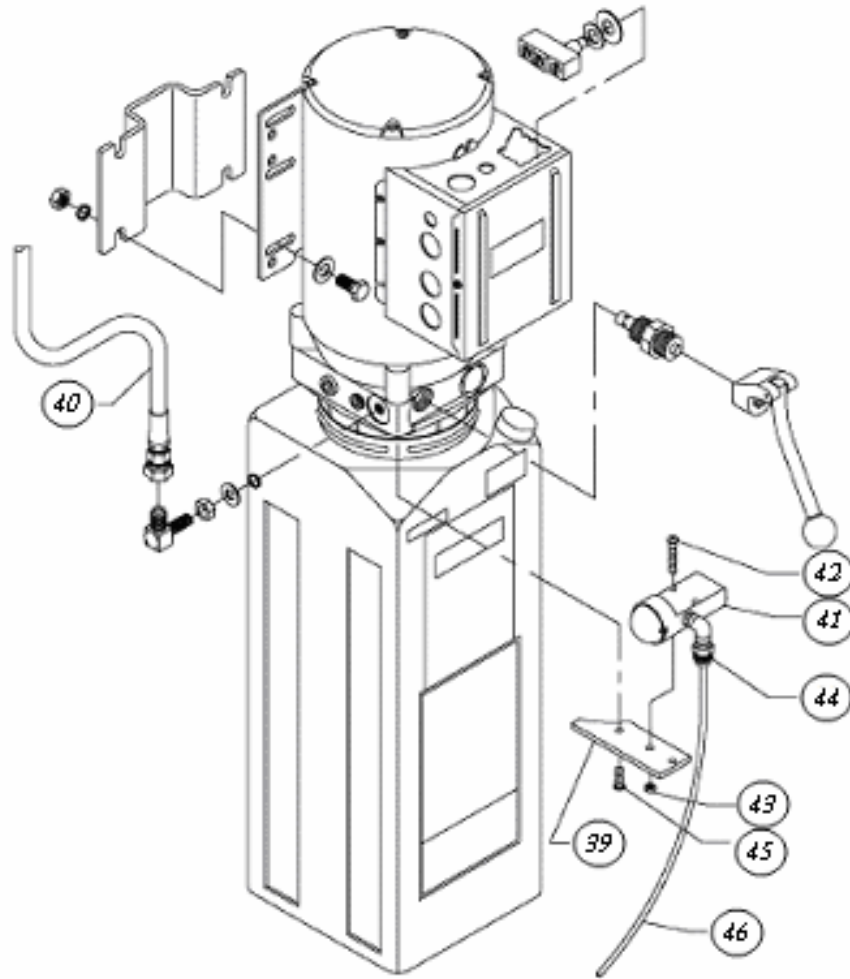

17.1 POWER PACK PARTS LIST

| Assembly No. | Part No. | Description |
|--------------|----------|-----------------------------------|
| 1 | 6-2298 | BOLT, 5/16" – 24" x 2-3/4" LG |
| 2 | 6-0774 | COUPLING (4 POST POWER PACK) |
| 3 | 6-2158 | SEAL SHAFT 0.5x1x0.25 |
| 4 | 6-1392 | CAPSCREW 5/16-18 x 1.00 SOCKET HD |
| 5 | 6-0916 | MICRO-SWITCH |
| 6 | 6-2301 | PACKAGE PLUG 9/16" SAE |
| 7 | 6-2157 | PLUMBING PLUG 9/16 SAE |
| 8 | 6-2162 | PLUMBING MAGNET |
| 9 | 6-2164 | SCREW TAPTITE TORX |
| 10 | 6-2165 | COVER ASY. SUCTION |
| 11 | 6-2166 | CLAMPHOSEADJ. INLET |
| 12 | 6-3782 | END HEAD UNIV. |
| 13 | 6-3553 | BLANK COVER |

| | | |
|----|--------|--------------------------------------|
| 14 | 6-1087 | VALVE CARTRIDGE CHECK |
| 15 | 6-2159 | WASHER 0.338x0.625x0.06 |
| 16 | 6-2167 | NUT 3/4"-16x1" HEX. 0.25 |
| 17 | 6-2168 | WASHER 3/4" INT. TOOTH |
| 18 | 6-1108 | RELEASE HANDLE ASS'Y |
| 19 | 6-2169 | SHCS, M6x1 .35MM |
| 20 | 6-2170 | WASHER 1/4 LC HI-COLLR |
| 21 | 6-1091 | RESERVOIR SCREW |
| 22 | 6-3790 | TANK 3.0 GAL WHITE |
| 23 | 6-0884 | INLET HOSE/FILTER ASS'Y |
| 24 | 6-1376 | BREATHER FILLER CAP |
| 25 | 6-1089 | RELIEF VALVE CAP |
| 26 | 6-3791 | RETURN HOSE 1/2" O.D. x 19.00" |
| 27 | 6-2154 | COMP. TUBE SLEEVE |
| 28 | 6-0875 | RESERVOIR O-RING |
| 29 | 6-0782 | PUMP ASSEMBLY |
| 30 | 6-3795 | RELIEF VALVE ASSEMBLY 180 BAR |
| 31 | 6-2153 | COMPRESSION TUBE NUT |
| 32 | 6-0880 | VALVE CARTRIDGE RELEASE MANUAL |
| 33 | 6-1846 | CABLE TIE 8" LONG WHITE |
| 34 | 6-2156 | WIRING ASSEMBLY AC 1PH FENNER |
| 35 | 6-2301 | PACKAGE PLUG 9/16" SAE |
| 36 | 6-2302 | ELECTRICAL STAKON NUT |
| 37 | 6-2151 | SPRING 0.48x0.063x0.42 |
| 38 | 6-2161 | PLUMB. PLUG 3/8NPT |
| 39 | 1-3365 | AIR LOCK BUTTON BRACKET |
| 40 | 1-3471 | HYD. HOSE PUMP 2P/SING IN-GROUND |
| 41 | 6-3548 | AIR LOCK BUTTON VALVE |
| 42 | 6-3549 | 6-32 SCREW 1-1/4" LG |
| 43 | 6-3550 | AIR LOCK BUTTON VALVE NUT |
| 44 | 6-0709 | SWL. ELBOW, 1/4" POLY x 1/8" NPT |
| 45 | 6-3552 | 12-24 3/4" HEX. HD SCREW |
| 46 | 8-0141 | TUBE, POLY., 1/4" DIA. x 0.038" WALL |

18.0 AVAILABLE ACCESSORIES



**Figure 10 - Truck Height-Extension Adapter, Part No. 3-1028
(Set of 4)**