

Revisions			
Rev	Description	Date	Initials
C	Updated drawing from old cad program	11/1/2010	TPA
D	Updated drawing to match actual mold features and dimension	3/26/2014	DVK

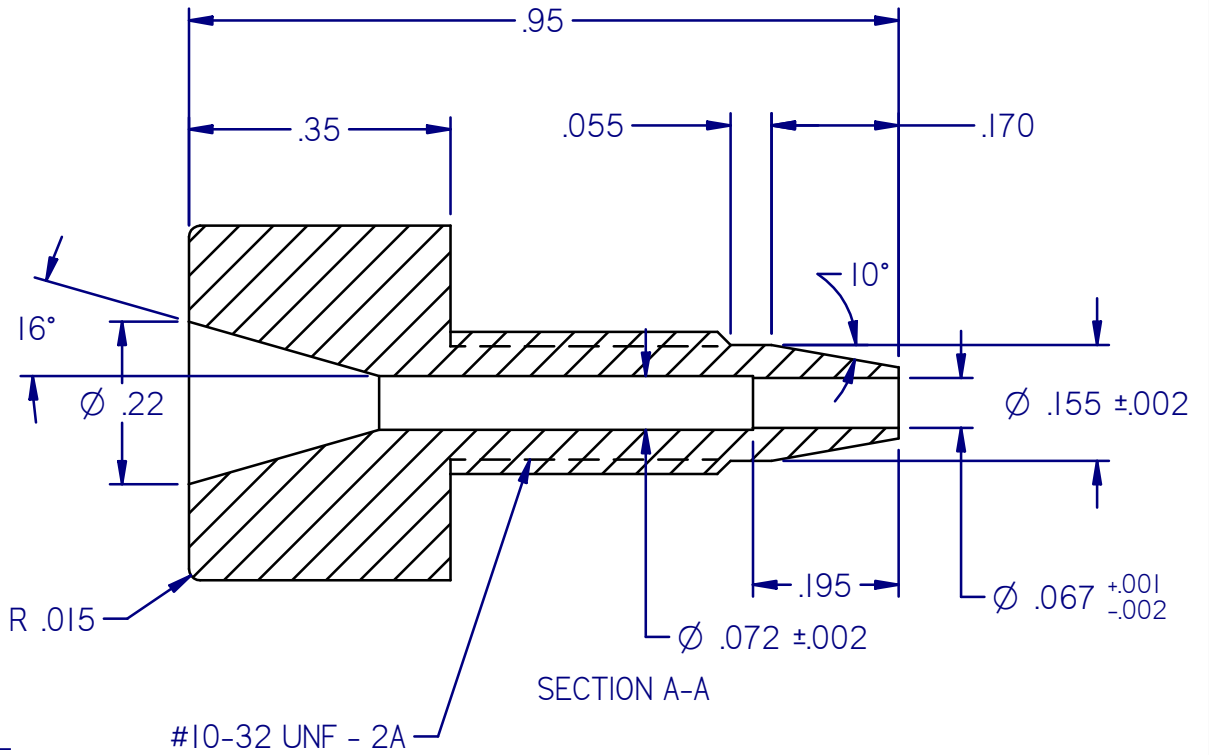
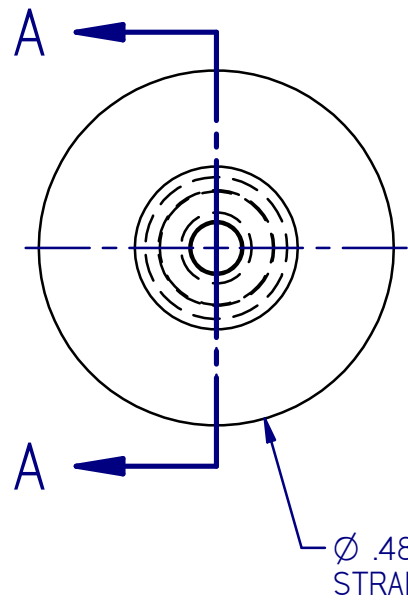

NOTES:

1. REMOVE ALL BURRS/FLASHING.
2. SURFACE FINISH AS MOLDED.
3. ALL RADII .031" MAX UNLESS NOTED.
4. ALL DRAFT ANGLES 1° MAX UNLESS NOTED.

CONFIDENTIAL:

This drawing is the property of TEI Chromatography. Any reproductions or modifications of this drawing or its contents without consent of Alltech is prohibited.

TEI Chromatography, Inc.

DESCRIPTION: Long Finger Tight Nut One-Peice

MATERIAL: PEEK

P/N: 2110664

GENERAL TOLERANCES

DECIMAL: XX ±.010"; XXX ±.005"

FRACTIONAL: ± 1/64"

ANGULAR: ±1/2°
UNLESS OTHERWISE SPECIFIED

DRAWN: DVK

APPROVED: SPS

DATE: 03/26/14

SCALE: 1 = 1

DRAWING NO: 0000992

REV
D

SHEET
1 OF 1

