

Sustainable Coils

Replacement Coil Solutions!

HORIZONTAL SLAB COILS

Revision Date: 7/17/17

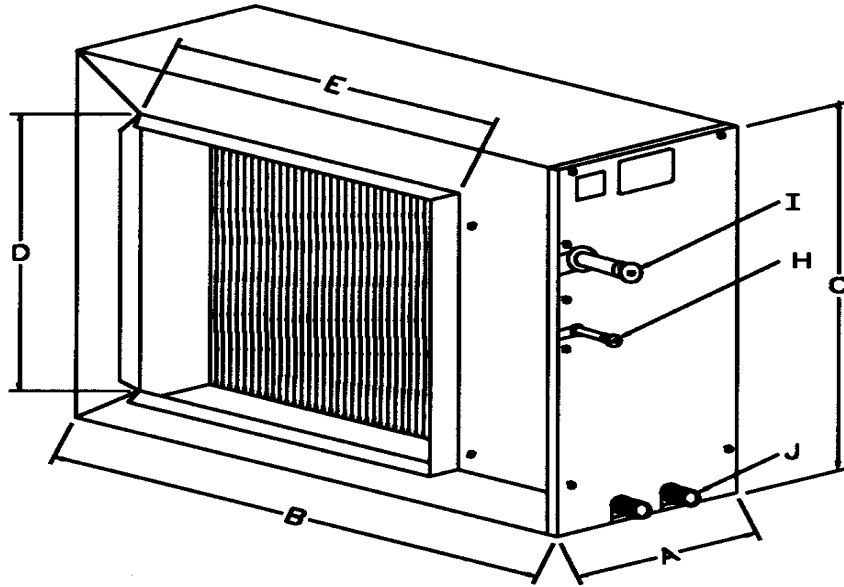

COIL MODEL	A	B	C	D	E	H	I	J
HS-24	10	20	25	21	14	3/8	3/4	3/4
HS-36	10	25	25	21	19	3/8	3/4	3/4
HS-48	10	30	25	21	24	3/8	7/8	3/4
HS-60	10	34	25	21	28	3/8	7/8	3/4

3/8 O.D. UNIGUARD® by Luvata copper alloy tubing to block formicary corrosion

Aluminum end plates to protect against rust corrosion

Louvered fins spaced at 14 FPI

Piston metered for R-22 refrigerant, additional R-410A piston optional

R-22 and R-410A expansion valve kits available upon request

Metal drain pan

Pre-swaged refrigerant connection, shipped with dry nitrogen holding charge

Internal refrigerant volumes: HS24=98.78, HS36=134.06, HS48=169.34, HS60=197.57

5 year replacement warranty

Visit our website at www.Sustainablecoils.com for further information regarding our complete product line.