



Made in USA



2024 CATALOG & PRICE LIST

216 S. Motor Ave. Azusa, CA 91702 Tel: (626) 789-2412
www.idealcookingproducts.com

FRONT PAGE	01
INDEX PAGE	02
HOT PLATE Series	03
GRIDDLE Series	04
BROILER Series	05
STOCK POT Series	06
COUNTER COMBINATION Series	07
SHISH KABAA Series	08
CHEESE MELTER & SALAMANDER Series	09
STEAM TABLE Series	10
OVEN RANGE 24 & 36 Series	11
OVEN RANGE 48 Series	12
OVEN RANGE 60 Series	13
OVEN RANGE 72 Series	14
FRYER Series	15
CONVECTION OVEN Series	16
VERTICAL BROILER (Gyro) Series	17
SPECIALTY EQUIPMENT	18
FOOD TRUCKS AND TRAILERS	19
TERMS AND WARRANTY	20

Ideal Commercial Cooking Products, Ink. Snack (24" Depth) and Heavy Duty (29" Depth) design, offer an easy to fit product in any chef's kitchen to maximize space and satisfy the most demanding needs and assuring optimal performance and low operating and maintenance costs. The double sided panels and heavy duty castings along with high efficiency BTU's burners complement these units' rough appearance. Models ranging from 12" to 84" front widths are available. Although any size or custom design can be specially order to acomodate any particular needs.

Ideal Cooking Products Range and Counter top Line-up align perfectly with other Ideal Products on height, depth and other design alike features such as large bull nose among others.



Made in USA



HOT PLATE Series

STANDARD FEATURES

Ideal Commercial Cooking Products Heavy Duty Hot Plates have a unique compact design offering an easy to fit product in any chef's kitchen to maximize space and satisfy the most demanding needs. Assuring optimal performance with low operating and maintenance costs. The double sided panels and heavy duty cast iron top grates and burners along with short and long venturiers complement these units rough appearance. Models ranging from two to eight lift-off open burners are available. Ideal Cooking Products Counter top Line-up align perfectly with other Ideal Products on height, depth and other design alike features such as bull noses. and same valve alinement height among others.

- Heavy gage stainless steel exteriors.
- 1" double side panels for better insulation.
- 5" stainless steel bull nose provides large extra work space.
- Unique 12" x 12" heavy cast iron top grate design allows pots to slide easy from section to section.
- Cast iron lift-off burner, rated at 26,000 btu/hr.
- All burners are equipped with continuous anti-clogging stainless steel pilots for instant ignition.
- Each burner controlled manually by a heavy duty knob.
- Large capacity full width removable crumb tray.
- Available in 12", 24", 30", 36", and 48" wide models.
- Complies with "NSF/ANSI Std. 4-2009 "Commercial, Rethermalization, and Powered Hot Food Holding and Transport Equipment"
- Conforms to ANSI STD Z83.11 Certified to CSA STD 1.8
- One year parts and labor warranty.



Heavy Duty Hot Plates

Model	Dimensions	Weight	Total BTU's/hr	Price List
IDHP-12	12"W x 29"D x 10"H	65 Lbs.	52,000	\$1,220.00
IDHP-24	24"W x 29"D x 10"H	115 Lbs	104,000	\$1,870.00
IDHP-30	30"W x 29"D x 10"H	145 Lbs	104,000	\$2,365.00
IDHP-36	36"W x 29"D x 10"H	160 Lbs	156,000	\$2,480.00
IDHP-48	48"W x 29"D x 10"H	215 Lbs	208,000	\$3,305.00



Step-Up Hot Plates

Model	Dimensions	Weight	Total BTU's/hr	Price List
IDHP-24SU	24"W x 29"D x 14"H	130 Lbs.	104,000	\$2,530.00
IDHP-36SU	36"W x 29"D x 14"H	195 Lbs	156,000	\$4,200.00
IDHP-48SU	48"W x 29"D x 14"H	260 Lbs	208,000	\$5,600.00



Front Row Hot Plates

Model	Dimensions	Weight	Total BTU's/hr	Price List
IDHP-12-1	12"W x 17"D x 10"H	45 Lbs.	26,000	\$ 770.00
IDHP-24-2	24"W x 17"D x 10"H	75 Lbs	52,000	\$1,695.00
IDHP-36-3	36"W x 17"D x 10"H	115 Lbs	78,000	\$2,155.00
IDHP-48-4	48"W x 17"D x 10"H	155 Lbs	104,000	\$2,870.00



Snack Line Hot Plates



Model	Dimensions	Weight	Total BTU's/hr	Price List
IDHP-12S	12"W x 25"D x 9"H	55 Lbs.	50,000	\$ 1,120.00
IDHP-24S	24"W x 25"D x 9"H	85 Lbs	100,000	\$1,695.00
IDHP-36S	36"W x 25"D x 9"H	130 Lbs	150,000	\$2,155.00
IDHP-48S	48"W x 25"D x 9"H	175 Lbs	200,000	\$2,870.00

Gas: 3/4" NPT rear gas connection, specify type of gas and altitude if over 2,000 feet.
Pressure: 5" W.C. - Natural Gas
 10" W.C. - Propane Gas
Note: Install the supplied pressure regulator at the inlet of the gas line.



Made in USA

Ideal Commercial Cooking Products, Inc. Heavy Duty Manual and thermostatically control Griddles have a unique compact design offering an easy to fit product in any chef's kitchen to maximize space and satisfy the most demanding needs and assuring optimal performance and low operating and maintenance costs.

Griddles are 3/4" thick on models 12" 48" and 1" on 60" and above. With a heavy gage stainless steel large perimeter splash to avoid spillage.

Ideal Cooking Products Counter top Line-up align perfectly with other Ideal Products on height, depth and other design alike features such as bull noses, chassis depth and height among others.



Snack Line Griddle Plates

Model	Dimensions	Weight	Total BTU's/hr	Price List
IDGR-12S	12"W x 25"D x 9"H	60 Lbs.	25,000	\$ 1,310.00
IDGR-24S	24"W x 25"D x 9"H	110 Lbs	50,000	\$ 1,955.00
IDGR-36S	36"W x 25"D x 9"H	165 Lbs	75,000	\$2,605.00
IDGR-48S	48"W x 25"D x 9"H	260 Lbs	100,000	\$3,235.00



Heavy Duty Manual Griddle Plates

Model	Dimensions	Weight	Total BTU's/hr	Price List
IDGR-12	12"W x 29"D x 10"H	105 Lbs.	30,000	\$1,505.00
IDGR-18	18"W x 29"D x 10"H	155 Lbs	30,000	\$2,025.00
IDGR-24	24"W x 29"D x 10"H	180 Lbs	60,000	\$2,255.00
IDGR-30	30"W x 29"D x 10"H	220 Lbs	90,000	\$2,575.00
IDGR-36	36"W x 29"D x 10"H	260 Lbs	90,000	\$2,920.00
IDGR-48	48"W x 29"D x 10"H	420 Lbs	120,000	\$3,585.00
IDGR-60	60"W x 29"D x 10"H	530 Lbs	150,000	\$5,450.00
IDGR-72	72"W x 29"D x 10"H	685 Lbs	180,000	\$6,695.00
IDGR-84	84"W x 29"D x 10"H	800 Lbs	210,000	\$7,120.00

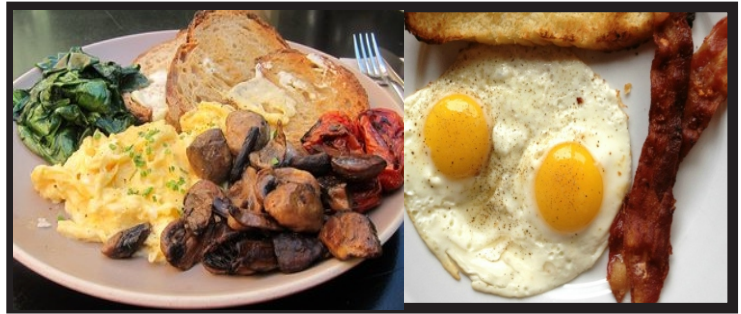

STANDARD FEATURES

- Heavy gage stainless steel exteriors.
- 1" double side panels for better insulation.
- 5" stainless steel bull nose provides large extra work space.
- Heavy 3/4" thick plate welded with a perimeter splash all around.
- Griddles 60" and 72" are 1" thick for better recovery enhancement and durability.
- One high performance burner for every 12" section.
- Each burner rated at 30,000 btu/hr.
- All burners are equipped with continuous anti-clogging stainless steel pilots for instant ignition.
- Each burner controlled manually by a heavy duty knob.
- Thermostatically controlled griddles (T) come with one thermostat that might supply 2 burners. Add \$185.00 net per thermostat if required.
- Snack Line griddles (S) measure 24" depth with a thickness plate of 1/2".
- Available in 12", 24", 30", 36", 48", 60" and 72" wide regular models and 12", 24", 30", 36" & 48" for Snack Line Models.
- Complies with "NSF/ANSI Std. 4-2009 "Commercial, Rethermalization, and Powered Hot Food Holding and Transport Equipment"
- Conforms to ANSI STD Z83.11 Certified to CSA STD 1.8
- One year parts and labor warranty.



NSF/ANSI Std. 4



Heavy Duty Thermo Griddle Plates

Intertek 5002553

Model	Dimensions	Weight	Total BTU's/hr	Price List
IDGR-24T	24"W x 29"D x 10"H	180 Lbs	60,000	\$3,645.00
IDGR-30T	30"W x 29"D x 10"H	220 Lbs	90,000	\$4,140.00
IDGR-36T	36"W x 29"D x 10"H	260 Lbs	90,000	\$5,380.00
IDGR-48T	48"W x 29"D x 10"H	420 Lbs	120,000	\$6,225.00
IDGR-60T	60"W x 29"D x 10"H	530 Lbs	150,000	\$9,165.00
IDGR-72T	72"W x 29"D x 10"H	685 Lbs	180,000	\$10,995.00
IDGR-84T	84"W x 29"D x 10"H	800 Lbs	210,000	\$11,960.00

Gas: 3/4" NPT rear gas connection, specify type of gas and altitude if over 2,000 feet.
Pressure: 5" W.C. - Natural Gas
 10" W.C. - Propane Gas
Note: Install the supplied pressure regulator at the inlet of the gas line.



Made in USA

STANDARD FEATURES

Ideal Commercial Cooking Products Heavy Duty Broilers have a unique compact design offering an easy to fit product in any chef's kitchen to maximize space and satisfy the most demanding needs and assuring optimal performance and low operating and maintenance costs.

The double sided panels and heavy duty castings along with high efficiency BTU's burners complement these units rough appearance.

Ideal special Broiler design can be converted into an Char-rock or a Radiant Broiler unit.

Models ranging from 12" to 72" width are available.

Ideal Cooking Products Counter top Line-up align perfectly with other Ideal Products on height, depth and other design alike features such as bull noses and same valve alignment height among others.

- Heavy gage stainless steel exteriors.
- 1" double side panels for better insulation.
- 5" stainless steel bull nose provides large extra work space.
- Heavy duty 6" x 24" or 5" x 21" (S) cast iron top grates.
- 19-1/2" (16" for Snack Line) Heavy Duty Radiant Covers evenly transmits the heat to the cooking area.
- High BTU's "I" Type burners, rated at 15,000 btu/hr. or 12,500 for Snack Line.
- Burners strategically located every 5-1/2" apart.
- All burners are equipped with continuous anti-clogging stainless steel pilots for instant ignition.
- Each burner controlled manually by a heavy duty knob.
- Large capacity full width removable crumb tray.
- Available in 12", 18", 24", 30", 36", 48", 60", 72" and 84" wide models.
- Complies with "NSF/ANSI Std. 4-2009 "Commercial, Rethermalization, and Powered Hot Food Holding and Transport Equipment"
- Conforms to ANSI STD Z83.11 Certified to CSA STD 1.8
- One year parts and labor warranty.



Heavy Duty Radiant Broilers

Model	Dimensions	Weight	Total BTU's/hr	Price List
IDBR-12	12"W x 29"D x 10"H	96 Lbs.	15,000	\$1,480.00
IDBR-18	18"W x 29"D x 10"H	144 Lbs	45,000	\$1,880.00
IDBR-24	24"W x 29"D x 10"H	192 Lbs	60,000	\$2,275.00
IDBR-30	30"W x 29"D x 10"H	240 Lbs	75,000	\$2,485.00
IDBR-36	36"W x 29"D x 10"H	288 Lbs	90,000	\$2,880.00
IDBR-48	48"W x 29"D x 10"H	384 Lbs	120,000	\$3,490.00
IDBR-60	60"W x 29"D x 10"H	480 Lbs	150,000	\$4,370.00
IDBR-72	72"W x 29"D x 10"H	576 Lbs	180,000	\$5,250.00
IDBR-84	84"W x 29"D x 10"H	675 Lbs	210,000	\$6,115.00

Snack Line Radiant Broilers

Model	Dimensions	Weight	Total BTU's/hr	Price List
IDBR-12S	12"W x 25"D x 9"H	72 Lbs.	12,500	\$1,365.00
IDBR-18S	18"W x 25"D x 9"H	108 Lbs	37,500	\$1,575.00
IDBR-24S	24"W x 25"D x 9"H	144 Lbs	50,000	\$1,920.00
IDBR-30S	30"W x 25"D x 9"H	180 Lbs	62,500	\$1,965.00
IDBR-36S	36"W x 25"D x 9"H	216 Lbs	75,000	\$2,430.00
IDBR-48S	48"W x 25"D x 9"H	288 Lbs	100,000	\$2,940.00



Ideal Broilers can be updated or customized for the outdoor or patio usage. A hood cover or a rotisserie motor with skewer bar can be adapt it, as well as side and back stainless steel flanges to insert them in prefabricated spaces. We also offer custom access doors for those special outdoor cooking areas. Call and ask for custom equipment and pricing.

Gas: 3/4" NPT rear gas connection, specify type of gas and altitude if over 2,000 feet.
Pressure: 5" W.C. - Natural Gas
 10" W.C. - Propane Gas
Note: Install the supplied pressure regulator at the inlet of the gas line.

216 S. Motor Ave. Azusa, CA 91702 Tel: (626) 789-2412

www.idealcookingproducts.com



Made in USA

STANDARD FEATURES

Ideal Commercial Cooking Products, Inc. Stock Pot and Mandarin Jet Ranges are build out of a heavy gage sheet metal steel chassis and its complemented with heavy duty cast iron three ring burner or 18 Tip Jet Burner with a 18" x 21" top grate for the Stock Pots and Heavy gage stainless steel welded all around cylinders for individual Mandarin Jet Ranges. Intended for rough daily use, we chose premium top of the line materials along with upgrades that assure the unit will last long. Moreover, the simple and efficient design allow the operator to keep the equipment clean at all times due to its large crumb tray that will hold all the spillage. Different design configurations and heights are offered to fit any cook needs.

- Stainless steel sides and front.
- High efficiency cast iron 3-Ring burner rated at 90,000 BTU/hr provides instant even heat.
- 120,000 BTU's 18 Tip Jet Burner for Mandarin Ranges.
- Adjustable gas valve with continuous pilot for instant ignition.
- Separate gas control for each burner.
- Heavy duty 6" legs with adjustable lever are standard.
- Large capacity removable crumb tray for easy cleaning.
- Available in different widths, depths, heights or special configurations (Step up units).
- Complies with "NSF/ANSI Std. 4-2009 "Commercial, Rethermalization, and Powered Hot Food Holding and Transport Equipment"
- Conforms to ANSI STD Z83.11 Certified to CSA STD 1.8
- One year parts and labor warranty.



Stock Pot Ranges

Double Stock Pot

Model	Dimensions	Weight	Total BTU's/hr	Price List
IDSP-18-24	18"W x 21"D x 24"H	110 Lbs.	90,000	\$ 1,100.00
IDSP-18-18	18"W x 21"D x 18"H	105 Lbs.	90,000	\$ 1,100.00
IDSP-18D	18"W x 40"D x 24"H	220 Lbs.	180,000	\$2,230.00
IDSP-36D	36"W x 21"D x 24"H	220 Lbs.	180,000	\$2,230.00
IDSP-54T	54"W x 21"D x 24"H	330 Lbs.	270,000	\$2,795.00

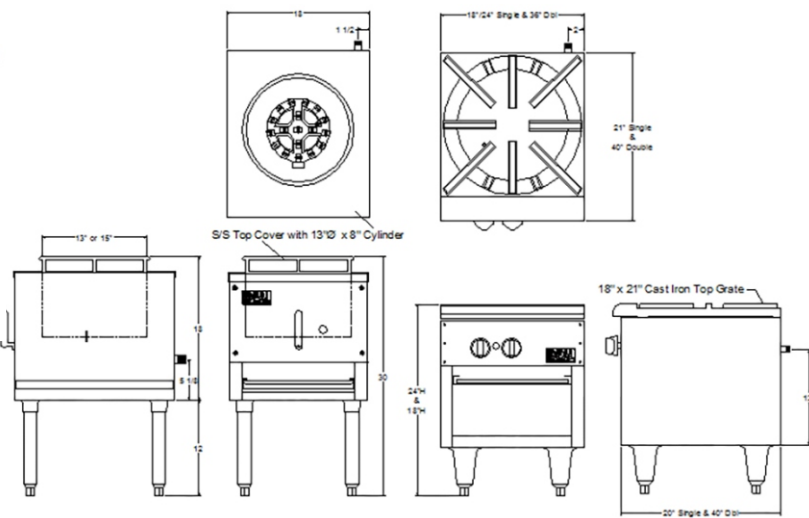

Mandarin Jet

Stock Pot



Jet (Mandarin) Ranges

Model	Dimensions	Weight	Total BTU's/hr	Price List
IDMJ-13	18"W x 21"D x 30"H	105 Lbs.	120,000	\$ 1,810.00
IDMJ-26	26"W x 27"D x 24"H	195 Lbs.	120,000	\$ 3,160.00
IDSP-18J	18"W x 21"D x 24"H	110 Lbs.	90,000	\$ 1,810.00
IDMJ-13D	36"W x 21"D x 30"H	210 Lbs.	240,000	\$ 3,170.00



**Carnitas Pot (IDMJ-26)
Pot (Cazo) not included**



Gas: 3/4" NPT rear gas connection, specify type of gas and altitud if over 2,000 feet.
Pressure: 5" W.C. - Natural Gas
 10" W.C. - Propane Gas
Note: Install the supplied pressure regulator at the inlet of the gas line.



Made in USA

Ideal Commercial Cooking Products, Inc. Combination Units vast variety of products offer any possible design arrangement to satisfy the most exigent chef needs and requirements or simply to fit and maximize the back yard spaces for those who love entertain and cook. The double sided panels and heavy duty chassis along with cast iron top grates and burners complement these units' rough appearance. Models ranging from 12" to 72" are available, either for heavy duty or Snack line. Ideal Commercial Cooking Products Counter top Line-up align perfectly with other Ideal Products on height, depth and other design alike features such as bull noses.



STANDARD FEATURES

- Heavy gage stainless steel top and exteriors.
- 1" double side panels for better insulation.
- Large stainless steel bull nose provides extra work space.
- Available in different configurations, widths, depths, heights or special custom design.
- Heavy duty cast iron top grates and burners for hot plate and broiler sections.
- Thick griddle plate with heavy gage perimeter welded all around.
- Each burner controlled manually by a heavy duty knob.
- Large capacity full width removable crumb tray or grease can.
- Complies with "NSF/ANSI Std. 4-2009 "Commercial, Rethermalization, and Powered Hot Food Holding and Transport Equipment"
- Conforms to ANSI STD Z83.11 Certified to CSA STD 1.8
- One year parts and labor warranty.



Snack Line Combination Units

Heavy Duty Combination Units

Model	Dimensions	Weight	Total BTU's/hr	Price List
IDGR-12HP12	24"W x 29"D x 10"H	200 Lbs.	82,000	\$3,010.00
IDBR-12HP12	24"W x 29"D x 10"H	225 Lbs	45,000	\$3,170.00
IDGR-24HP12	36"W x 29"D x 10"H	267 Lbs	112,000	\$3,780.00
IDGR-24BR12	36"W x 29"D x 10"H	332 Lbs	135,000	\$4,205.00
IDGR-24HP24	48"W x 29"D x 10"H	322 Lbs	164,000	\$4,465.00
IDGR-36HP12	48"W x 29"D x 10"H	335 Lbs	142,000	\$4,485.00
IDGR-24BR24	48"W x 29"D x 10"H	412 Lbs	120,000	\$5,130.00
IDGR-48HP12	60"W x 29"D x 10"H	400 Lbs	172,000	\$5,255.00

Model	Dimensions	Weight	Total BTU's/hr	Price List
IDGR-12HP12S	24"W x 24"D x 10"H	200 Lbs.	70,000	\$2,390.00
IDBR-12HP12S	24"W x 24"D x 10"H	225 Lbs	57,500	\$2,655.00
IDGR-24HP12S	36"W x 24"D x 10"H	267 Lbs	95,000	\$3,005.00
IDGR-24BR12S	36"W x 24"D x 10"H	332 Lbs	62,500	\$3,470.00
IDGR-24HP24S	48"W x 24"D x 10"H	322 Lbs	140,000	\$3,705.00
IDGR-36HP12S	48"W x 24"D x 10"H	335 Lbs	120,000	\$3,965.00
IDGR-24BR24S	48"W x 24"D x 10"H	412 Lbs	75,000	\$4,250.00
IDGR-48HP12S	60"W x 24"D x 10"H	400 Lbs	145,000	\$4,665.00

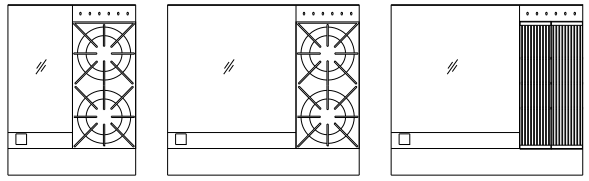

IDGR-12HP12 IDGR-24HP12 IDGR-24BR12

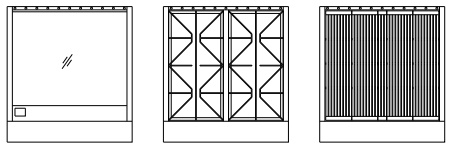

IDGR-24S IDHP-24S IDBR-24S

Snack line can be configured within these models, and others.

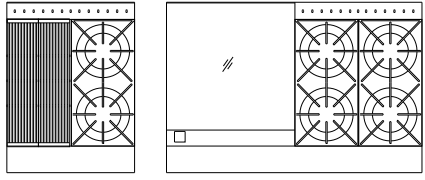

IDBR-12HP12 IDGR-24HP24

Gas: 3/4" NPT rear gas connection, specify type of gas and altitud if over 2,000 feet.
 Pressure: 5" W.C.- Natural Gas
 10" W.C. - Propane Gas
 Note: Install the supplied pressure regulator at the inlet of the gas line.

COUNTER SNK. & HD COMBINATION UNIT Series



Made in USA

Ideal Commercial Cooking Products, Inc. Shish Kabob Broilers unique compact all welded design offers an easy to fit product in any Mediterranean Cuisine and maximizes space to satisfy the most demanding needs and assuring optimal performance and low operating and maintenance costs. With high efficiency BTU's burners these broilers drip down the meat juices onto the radiants to ear the flames and smoke a unique flavor. Model ranging from 24" to 84" width are available. Ideal Cooking Products Counter top Line-up align perfectly with other Ideal Products on height, depth and other design alike features.

STANDARD FEATURES

- Heavy gage stainless steel exteriors.
- 14ga. Stainless Steel Skewer Holders.
- Strong inner chassis welded all around.
- 16" Heavy duty cast iron radiant covers evenly transmits the heat to the cooking area.
- High efficient "I" Type burners, rated at 30,000 BTU's., located strategically equally apart.
- All burners are equipped with continuous anti-clogging stainless steel pilots for instant ignition.
- Each burner controlled manually by a heavy duty knob.
- Large capacity welded Stainless Steel full width removable crumb tray.
- Available in 24", 30", 36", 48", 60", 72" and 84" wide models.
- Complies with "NSF/ANSI Std. 4-2009 "Commercial, Rethermalization, and Powered Hot Food Holding and Transport Equipment"
- Conforms to ANSI STD Z83.11 Certified to CSA STD 1.8
- One year parts and labor warranty.



Shown with Lava-Rock

Gas: 3/4" NPT rear gas connection, specify type of gas and altitude if over 2,000 feet.
Pressure: 5" W.C. - Natural Gas
 10" W.C. - Propane Gas
Note: Install the pressure regulator supplied with the appliance at the inlet of the gas line.



Model: IDSKB-48
(Shown with optional Rotisserie)



Intertek



Intertek



Model: IDSKB-48
(w/ Optional Skewer Level Racks)



IDSKB-24

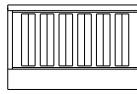

IDSKB-36

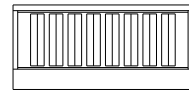

IDSKB-48

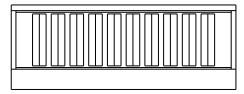

IDSKB-60

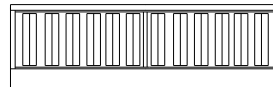

IDSKB-72

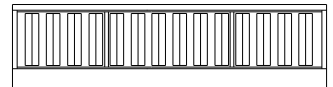

IDSKB-84

Shish Kabba Series

Model	Dimensions	Weight	Total BTU's/hr	Price List	Equip. Stands Price List
IDSKB-24	24"W x 26"D x 16"H	130 Lbs.	120,000	\$3,430.00	\$ 610.00
IDSKB-30	30"W x 26"D x 16"H	150 Lbs	150,000	\$4,760.00	\$ 765.00
IDSKB-36	36"W x 26"D x 16"H	165 Lbs	180,000	\$5,710.00	\$ 930.00
IDSKB-48	48"W x 26"D x 16"H	220 Lbs	240,000	\$7,155.00	\$ 1,115.00
IDSKB-60	60"W x 26"D x 16"H	280 Lbs	300,000	\$8,580.00	\$ 1,555.00
IDSKB-72	72"W x 26"D x 16"H	355 Lbs	360,000	\$10,535.00	\$1,865.00
IDSKB-84	84"W x 26"D x 16"H	395 Lbs	420,000	\$12,325.00	\$2,140.00



STANDARD FEATURES

- Stainless steel sides and front.
- High efficiency Infrared broiler provides instant even heat.
- Adjustable gas valve with continuous pilot for instant ignition.
- Separate gas control for each burner (when more than one).
- Equipped with a chrome plated heavy duty rack that can be position in different heights.
- Can be easily wall mounted or attached to our range and counter line.
- Full width crumb tray for easy cleaning.
- Cheese Melter available in 24", 36", 48", 60" and 72", while our Salamander Broilers are 24" and 36" widths.
- The Salamander Broiler can be accommodated in three easy spring loads vertical adjustments and a pull out carriage tray.
- Complies with "NSF/ANSI Std. 4-2009 "Commercial, Rethermalization, and Powered Hot Food Holding and Transport Equipment"
- Conforms to ANSI STD Z83.11 Certified to CSA STD 1.8
- One year parts and labor warranty.

Ideal Commercial Cooking Products, Inc. Cheese Melters and Salamander Broilers are perfect for browning, broiling and finishing due to their high performance infra red-burners that provide instant, even heating throughout the rack surface. Their design is perfect for preparation of melted cheese and a wide variety of dishes. Ideal Cheese Melters serve as an outstanding auxiliary broiler for steaks, fish and lobster. They come standard with (2) two position rack heights to accommodate the chrome rack to the chefs needs. The Salamander Broiler on the other hand can be adjusted in (3) three different high positions and comes with a pull out carriage tray to ease the process. Both units can be easily mounted over our ranges top shelves with the help of (2) two reinforced channels or they can be wall mounted against the wall with the supplied brackets. Specify if either the unit will be wall mounted or over the range shelf to provide you with the right mounting brackets.



Cheese Melters Broilers

Salamander Broilers

Model	Dimensions	Weight	Total BTU's/hr	Price List
IDCM-24S	24"W x 12"D x 12"H	70 Lbs.	17,500	\$1,945.00
IDCM-36S	36"W x 12"D x 12"H	95 Lbs.	30,000	\$2,610.00
IDCM-24	24"W x 18"D x 18"H	95 Lbs.	20,000	\$2,360.00
IDCM-36	36"W x 18"D x 18"H	135 Lbs.	35,000	\$2,965.00
IDCM-48	48"W x 18"D x 18"H	180 Lbs.	40,000	\$4,255.00
IDCM-60	60"W x 18"D x 18"H	230 Lbs.	55,000	\$4,680.00
IDCM-72	72"W x 18"D x 18"H	275 Lbs.	70,000	\$5,940.00

Model	Dimensions	Weight	Total BTU's/hr	Price List
IDSB-24	24"W x 18"D x 18"H	150 Lbs.	20,000	\$3,425.00
IDSB-36	36"W x 18"D x 18"H	185 Lbs.	35,000	\$4,115.00

Gas: 3/4" NPT rear gas connection, specify type of gas and altitud if over 2,000 feet.

Pressure: 5" W.C.- Natural Gas
10" W.C. - Propane Gas

Note: Install the supplied pressure regulator at the inlet of the gas line.



Made in USA

STANDARD FEATURES

Ideal Commercial Cooking Products, inc. Steam Tables offer a new concept for food warmer units. A heavy gage stainless steel front and sides complement the 16 gage welded stainless steel water pan along with a 8" front cutting board to hold serving or preparation plates. Water pans come with a 1 1/4" diameter drain (on the Bain Marie Style) for easy cleaning and unloading water. It can be order as bain marie, or aérohot style and a cabinet with a large storage bottom base and 6" diameter strong casters for easy mobility. Cabinet units can be complemented with optional stainless steel swing doors for a neater

- Heavy gage Stainless Steel front and sides.
- Welded Stainless Steel 8" deep x 12" x 20" front to back water pan accommodates standard food inserts.
- Aérohot Style comes with individual controls and water pans at an extra 15% of the list price.
- Stainless Steel "I" type burners rated at 12,500 BTU/hr.
- Adjustable gas valve with continuous pilot for instant ignition.
- Available in 2, 3, 4, 5 and 6 wells.
- Optional cabinet style with swing bottom Stainless Steel doors.
- Complies with "NSF/ANSI Std. 4-2009 "Commercial, Rethermalization, and Powered Hot Food Holding and Transport Equipment"
- Conforms to ANSI STD Z83.11 Certified to CSA STD 1.8
- One year parts and labor warranty.

Gas: 3/4" NPT rear gas connection, specify type of gas and altitude if over 2,000 feet.
Pressure: 5" W.C. - Natural Gas
 10" W.C. - Propane Gas



Model: IDST-2 Bain Marie Style

Model: IDST-3 Aérohot Style

Model	Dimensions	Bain Marie Style			Aérohot Style			Extra features (Net Price)	
		Weight	Total BTU's/hr	Price List	Weight	Total BTU's/hr	Price List	Cabinets & Doors	Sneeze Guard
IDST-1	15"W x 23"D x 36"H	60 Lbs	12,500	\$1,785.00	60 Lbs	12,500	\$1,785.00	\$600.00	\$690.00
IDST-2	29"W x 23"D x 36"H	90 Lbs	12,500	\$2,270.00	95 Lbs	25,000	\$2,590.00	\$950.00	\$1,085.00
IDST-3	43"W x 23"D x 36"H	120 Lbs	12,500	\$3,050.00	130 Lbs	37,500	\$3,465.00	\$1,400.00	\$1,620.00
IDST-4	57"W x 23"D x 36"H	155 Lbs	25,000	\$3,910.00	170 Lbs	50,000	\$4,480.00	\$1,845.00	\$2,085.00
IDST-5	71"W x 23"D x 36"H	195 Lbs	25,000	\$4,750.00	215 Lbs	62,500	\$5,475.00	\$2,295.00	\$2,725.00
IDST-6	85"W x 23"D x 36"H	235 Lbs	25,000	\$5,530.00	255 Lbs	75,000	\$6,375.00	\$2,725.00	\$2,880.00
IDST-7	99"W x 23"D x 36"H	275 Lbs	25,000	\$6,450.00	300 Lbs	87,500	\$7,435.00	\$3,495.00	\$3,690.00



Made in USA

Ideal Commercial Cooking Products, Inc. Oven Ranges innovative design provides the most useful features at an affordable cost. Finally, you can have an intelligent range design that allows to integrate any configuration desired to have all in one. Our oven ranges are made of heavy duty materials. All stainless steel exteriors front and sides with a double insulated wall. Our top grates and open burners are made of heavy cast iron materials. The oven interior is fully insulated with porcelain coating to ensure even heat and easy cleaning, yet rough enough to withstand the constant heavy usage of a busy kitchen.



STANDARD FEATURES

- Stainless steel sides and front.
- Double side panels with insulation.
- Wide heavy duty 5" landing ledge (Bull nose) provides extra work space.
- Separate heavy duty manual control knobs for each burner.
- 12" x 12" heavy duty cast iron top grates and burners rated at 26,000 BTU/hr. 35,000 BTU's for standard oven and 27,000 for small one.
- Top Griddle plate can be converted into a thermostatically control unit. (1) One Thermostat for every (2) two burners.
- Adjustable oven thermostat ranges temperatures from 150 to 500 degrees F.
- Safety valve shuts off the gas in case the pilot flame turns off.
- One chrome plated rack that can be adjusted in two different positions.
- 2 1/2" wide stainless steel grease through for 3/4" thick griddles and large capacity full width crumb tray for open burners or broilers.
- Complies with "NSF/ANSI Std. 4-2009 "Commercial, Rethermalization, and Powered Hot Food Holding and Transport Equipment"
- Conforms to ANSI STD Z83.11 Certified to CSA STD 1.8
- One year parts and labor warranty.

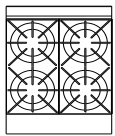

IDRG-4

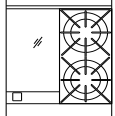

IDRG-2G12

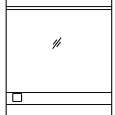

IDRG-G24

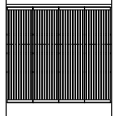

IDRG-B24



24" Oven Range Series

Model	Dimensions	Weight	Total BTU's/hr	Price List
IDRG-4	24"W x 29"D x 56"H	340 Lbs.	134,000	\$3,540.00
IDRG-2G12	24"W x 29"D x 56"H	355 Lbs	112,000	\$4,970.00
IDRG-G24	24"W x 29"D x 56"H	375 Lbs	90,000	\$6,090.00
IDRG-B24	24"W x 29"D x 56"H	395 Lbs	90,000	\$5,150.00

Gas: 3/4" NPT rear gas connection, specify type of gas and altitude if over 2,000 feet.
Pressure: 5" W.C. - Natural Gas
 10" W.C. - Propane Gas
Note: Install the pressure regulator supplied with the appliance, at the inlet of the gas line.

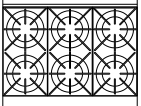

IDRG-6

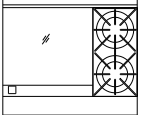

IDRG-2G24

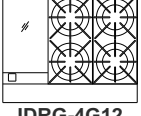

IDRG-4G12



IDRG-G36

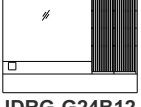

IDRG-G24B12



IDRG-B36



36" Oven Range Series

Model	Dimensions	Weight	Total BTU's/hr	Price List
IDRG-6	36"W x 29"D x 56"H	495 Lbs.	191,000	\$4,675.00
IDRG-2G24	36"W x 29"D x 56"H	540 Lbs	147,000	\$6,645.00
IDRG-4G12	36"W x 29"D x 56"H	525 Lbs	169,000	\$6,430.00
IDRG-G36	36"W x 29"D x 56"H	550 Lbs	125,000	\$6,275.00
IDRG-G24B12	36"W x 29"D x 56"H	558 Lbs	110,000	\$6,865.00
IDRG-B36	36"W x 29"D x 56"H	565 Lbs	125,000	\$7,155.00



24" & 36" Oven Range Series



Made in USA

Ideal Commercial Cooking Products, Inc. Oven Ranges innovative design provides the most useful features at an affordable cost. Finally, you can have an intelligent range design that allows to integrate any configuration desired to have all in one. Our oven ranges are made of heavy duty materials. All stainless steel front exteriors and sides with a double insulated wall. Our top grates and open burners are made of heavy cast iron materials. The oven interior is fully insulated with porcelain coating to ensure even heat and easy cleaning, yet rough enough to withstand the constant heavy usage of a busy kitchen.



Model: IDRG-2G36

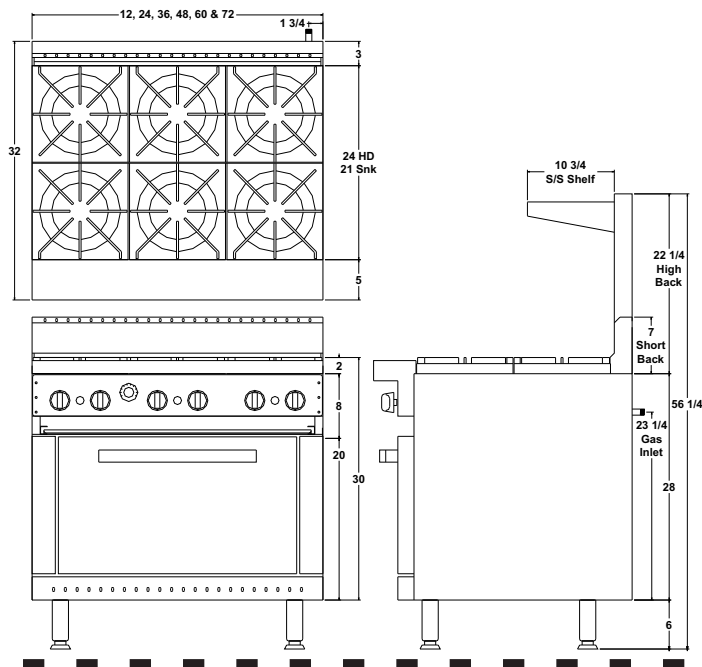

STANDARD FEATURES

- Stainless steel sides and front.
- Double side panels with insulation.
- Wide heavy duty 5" landing ledge (Bull nose) provides extra work space.
- Separate heavy duty manual control knobs for each burner.
- 12" x 12" heavy duty cast iron top grates and burners rated at 26,000 BTU/hr.
- Adjustable oven thermostat ranges temperatures from 150 to 500 degrees F.
- 35,000 BTU's for standard oven and 27,000 for small one.
- Safety valve shuts off the gas in case the pilot flame turns off.
- One chrome plated rack that can be adjusted in two different positions.
- 2 1/2" wide stainless steel grease through for 3/4" thick griddles and large capacity full width crumb tray for open burners or broilers.
- Complies with "NSF/ANSI Std. 4-2009 "Commercial, Rethermalization, and Powered Hot Food Holding and Transport Equipment"
- Conforms to ANSI STD Z83.11 Certified to CSA STD 1.8
- One year parts and labor warranty.



Model	Dimensions	Weight	Total BTU's/hr	Price List
IDRG-8	48"W x 29"D x 56"H	680 Lbs.	243,000	\$5,655.00
IDRG-2G36	48"W x 29"D x 56"H	735 Lbs	177,000	\$7,760.00
IDRG-4G24	48"W x 29"D x 56"H	715 Lbs	199,000	\$8,620.00
IDRG-6G12	48"W x 29"D x 56"H	700 Lbs	221,000	\$8,620.00
IDRG-G48	48"W x 29"D x 56"H	750 Lbs	155,000	\$8,590.00
IDRG-G24B24	48"W x 29"D x 56"H	770 Lbs	155,000	\$10,150.00
IDRG-B48	48"W x 29"D x 56"H	785 Lbs	155,000	\$10,050.00

Note: These specifications apply for units with one oven (standard on left side). For an additional oven add \$750 Net, plus 25,000 BTU's extra and the weight will increase 60 lbs.

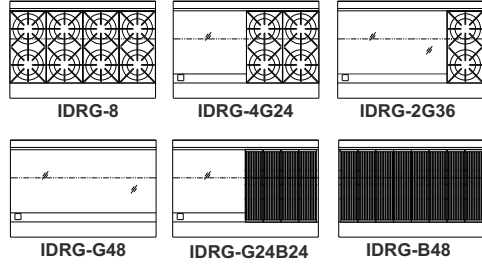

Ideal 48" Ranges come with high front and shelf as standard. If you require a short back stub instead pointed out in your order. For units with two small ovens rather than one full oven and open cabinet (default models) add in parenthesis a number (2) at the end of the model to denote this change.

For instance: IDRG-4G24(2). The price will increase a \$600.00 net and a set of casters (4) for these models are priced at \$180.00 net. **Note:** Go to page 14 for different option configurations and pricing. If you do not see what you are looking for, please call and let us know. We will custom design it to fit your needs.

- Gas:** 3/4" NPT rear gas connection, specify type of gas and altitude if over 2,000 feet.
- Pressure:** 5" W.C. - Natural Gas
10" W.C. - Propane Gas
- Note:** Install the pressure regulator supplied with the appliance, at the inlet of the gas line.



Made in USA

Ideal Commercial Cooking Products, Inc. Oven Ranges innovative design provides the most useful features at an affordable cost. Finally, you can have an intelligent range design that allows to integrate any configuration desired to have all in one. Our oven ranges are made of heavy duty materials. All stainless steel front exteriors and sides with a double insulated wall. Our top grates and open burners are made of heavy cast iron materials. The oven interior is fully insulated with porcelain coating to ensure even heat and easy cleaning, yet rough enough to withstand the constant heavy usage of a busy kitchen.



Model: IDRG-2G48(2)

Gas: 3/4" NPT rear gas connection, specify type of gas and altitude if over 2,000 feet.
 Pressure: 5" W.C. - Natural Gas
 10" W.C. - Propane Gas
 Note: Install the pressure regulator supplied with the appliance, at the inlet of the gas line.



STANDARD FEATURES

- Stainless steel sides and front.
- Double side panels with insulation.
- Wide heavy duty 5" landing ledge (Bull nose) provides extra work space.
- Separate heavy duty manual control knobs for each burner.
- 12" x 12" heavy duty cast iron top grates and burners rated at 26,000 BTU/hr.
- 35,000 BTU's for oven.
- Top Griddle plate can be converted into a thermostatically control unit. (1) One Thermostat for every (2) two burners.
- Adjustable oven thermostat ranges temperatures from 150 to 500 degrees F.
- Safety valve shuts off the gas in case the pilot flame turns off.
- One chrome plated rack that can be adjusted in two different positions.
- 2 1/2" wide stainless steel grease through for 3/4" thick griddles and large capacity full width crumb tray for open burners or broilers.
- Complies with "NSF/ANSI Std. 4-2009 "Commercial, Rethermalization, and Powered Hot Food Holding and Transport Equipment"
- Conforms to ANSI STD Z83.11 Certified to CSA STD 1.8

Model	Dimensions	Weight	Total BTU's/hr	Price List
IDRG-10	60"W x 29"D x 56"H	850 Lbs.	295,000	\$7,955.00
IDRG-4G36	60"W x 29"D x 56"H	905 Lbs	229,000	\$11,675.00
IDRG-6G24	60"W x 29"D x 56"H	885 Lbs	251,000	\$11,675.00
IDRG-2G48	60"W x 29"D x 56"H	920 Lbs	207,000	\$10,785.00
IDRG-G60	60"W x 29"D x 56"H	940 Lbs	185,000	\$11,340.00
IDRG-G24B36	60"W x 29"D x 56"H	965 Lbs	185,000	\$11,810.00
IDRG-G36B24	60"W x 29"D x 56"H	960 Lbs	185,000	\$12,740.00
IDRG-4G18B18	60"W x 29"D x 56"H	920 Lbs	214,000	\$13,710.00
IDRG-B60	60"W x 29"D x 56"H	980 Lbs	185,000	\$12,465.00

Note: These specifications apply for units with one oven (standard on left side). For an additional oven add \$ 500.00 Net, plus 35,000 BTU's extra and the weight will increase 65 lbs.

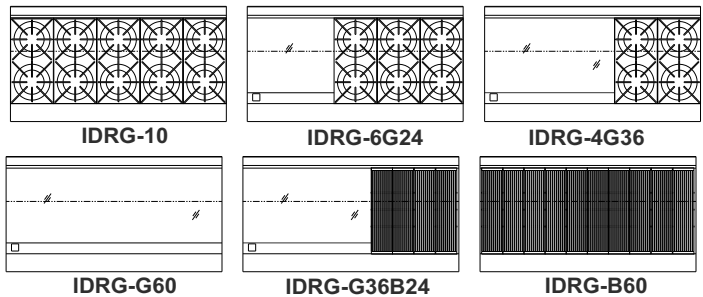

Ideal 60" Ranges come with high front and shelf as standard. If you require a short back stub instead pointed out in your order. For units with two ovens rather than one full oven and open cabinet (default models) add in parenthesis a number (2) at the end of the model to denote this change. **For instance: IDRG-4G36(2)**. The price will increase \$750.00 net and a set of (6) four casters for these models are priced at \$250.00 net.

Note: Go to page 14 for different option configurations and pricing. If you do not see what you are looking for, please call and let us know. We will custom design it to fit your needs.



Made in USA



STANDARD FEATURES

- Stainless steel sides and front.
- Double side panels with insulation.
- Wide heavy duty 5" landing ledge (Bull nose) provides extra work space.
- Separate heavy duty manual control knobs for each burner.
- 12" x 12" heavy duty cast iron top grates and burners rated at 26,000 BTU/hr.
- 35,000 BTU's for oven.
- Top Griddle plate can be converted into a thermostatically control unit. (1) One Thermostat for every (2) two burners.
- Adjustable oven thermostat ranges temperatures from 150 to 500 degrees F.
- Safety valve shuts off the gas in case the pilot flame turns off.
- One chrome plated rack that can be adjusted in two different positions.
- 2 1/2" wide stainless steel grease through for 3/4" thick griddles and large capacity full width crumb tray for open burners or broilers.
- Complies with "NSF/ANSI Std. 4-2009 "Commercial, Rethermalization, and Powered Hot Food Holding and Transport Equipment"
- Conforms to ANSI STD Z83.11 Certified to CSA STD 1.8

CUSTOM YOUR RANGE

Net Prices:

- Units come standard with an oven and open cabinet. Add \$750.00 net for an extra oven.
- Units come with high back and shelf standard. If low back stub is desired point it up while ordering.
- Add \$800.00 for every Foot of Raised Griddle (12, 24 & 36) with a chrome rack underneath the griddle.
- Add \$600.00 net for an additional configuration (Up to 2 choices is standard).
- Add \$250.00 net if preferred casters (set of 6) instead of regular 6" Legs.
- Add \$250.00 net per Griddle thermostat. Note: One thermostat supplies every 2 burners.
- Add \$90.00 net per extra oven chrome racks if required.

Model	Dimensions	Weight	Total BTU's/hr	Price List
IDRG-12	72"W x 29"D x 56"H	1,020 Lbs.	347,000	\$9,210.00
IDRG-6G36	72"W x 29"D x 56"H	1,073 Lbs	281,000	\$12,050.00
IDRG-4G48	72"W x 29"D x 56"H	1,090 Lbs	259,000	\$12,295.00
IDRG-6B36	72"W x 29"D x 56"H	1,098 Lbs	281,000	\$13,480.00
IDRG-G72	72"W x 29"D x 56"H	1,125 Lbs	215,000	\$13,460.00
IDRG-G36B36	72"W x 29"D x 56"H	1,190 Lbs	215,000	\$13,480.00
IDRG-G24B48	72"W x 29"D x 56"H	1,160 Lbs	215,000	\$14,125.00
IDRG-4G24B24	72"W x 29"D x 56"H	1,110 Lbs	259,000	\$17,940.00
IDRG-B72	72"W x 29"D x 56"H	1,175 Lbs	215,000	\$15,705.00

Note: These specifications apply for units with one oven (standard on the left side). For an additional oven add \$500 Net, plus 35,000 BTU's extra and the weight will increase 75 lbs.



Model: IDRG-4G24B24(2)



Intertek



Intertek

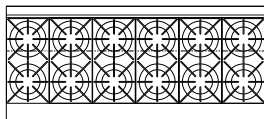

IDRG-12

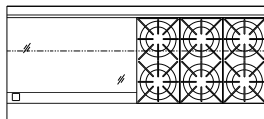

IDRG-6G36

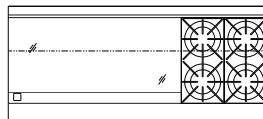

IDRG-4G48

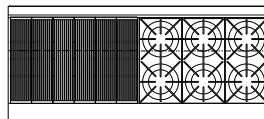

IDRG-6B36

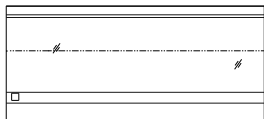

IDRG-G72

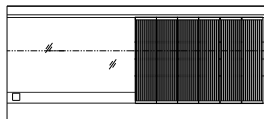

IDRG-G36B36

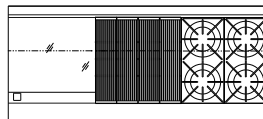

IDRG-4G24B24

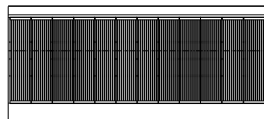

IDRG-B72

Gas: 3/4" NPT rear gas connection, specify type of gas and altitude if over 2,000 feet.

Pressure: 5" W.C. - Natural Gas
10" W.C. - Propane Gas

Note: Install the pressure regulator supplied with the appliance, at the inlet of the gas line.



Ideal Commercial Cooking Products, Inc. Fryer's Series are design and build for all purpose frying. These fryers have an efficient tube design that allows oil to cook at its maximum and with the help of its Hi-limit thermostat the heat recovers rapidly, helping the chef's at the most demanding hours. The fryers use a millivolt temperature control circuit, therefore no electrical hook up is required. All the fryer's components are precisely assembled and welded to avoid any leaks and to ensure a strong and long lasting product. We offer three models for your convenience; 3 burners (40 lbs), 4 burners (50 lbs) & 5 burners (90 lbs) with large frying areas. They comply, both with Gas Safety and NSF Regulations.

STANDARD FEATURES

- Heavy gage sand blasted stainless steel tank.
- 14" x 14" x 19" Frying area.
- Two removable large and resistant fry nickel plated wire mesh baskets with plastic handles.
- 6" Appliance Legs
- Double panel doors.
- Fine and resistant wire mesh crumb screen
- High efficient cast iron burners.
- Robertshaw Hi-limit and thermostat components
- Millivolt temperature control circuit.
- 1-1/4" drain valve with one drain nipple.
- Caters come as an extra accessories (\$100.00 net per 4)
- Stainless steel front and door.
- One year parts and labor warranty.
- Complies with "ANS Z83.11b-/CSA 1.8-2009 Food Service Equipment" and NSF /ANSI 4.

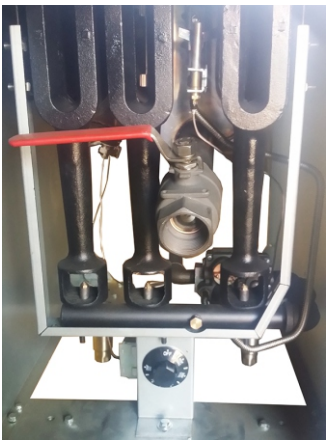

High efficient cast iron burners rated at 30,000 BTU's/hr each that transfers heat rapidly and fast heat recovery with a built in heat deflector (baffle). Along with top of the line Hi-limit thermostat and millivolt safety valve that maintains accurate oil temperature.

Stainless steel strongly welded tank with an extra sand blasted layer for sanitation safety. With a frying area of 14" x 14" for models FR-40 and FR-50. Models FR-90 has a 18" x 18" frying area. Both with a large cool zone to capture food residues to prolong the oil life.



Model: IDFR-40



Model: IDFR-90

Fryer Series

Model	#'s of Tubes	Dimensions	Weight	Total BTU's/hr	Price List
IDFR-40	3	16"W x 34"D x 45"H	165 Lbs.	90,000	\$2,520.00
IDFR-50	4	16"W x 34"D x 45"H	175 Lbs	120,000	\$3,055.00
IDFR-90	5	21"W x 34"D x 45"H	220 Lbs	150,000	\$4,135.00

Gas: 3/4" NPT rear gas connection, specify type of gas and altitude if over 2,000 feet.
Pressure: 5" W.C. - Natural Gas
 10" W.C. - Propane Gas
Note: Install the adequate pressure regulator at the inlet of the gas line.



Ideal standard size Convection ovens offer a solid construction and versatility for different types of cook preparation with set temperatures and cook times 20-30% lower than regular static ovens. The independent door assembly provides wide door opening with no restrictions and free from the servicing, usually associated with chain driven doors. Available in single unit or double deck options.



STANDARD FEATURES

- Three (3) inshot burners rated at 18,000 BTU/hr ea.
- Nat. Gas built with LP conversion kit.
- Independent large doors with full view windows.
- 2 speed, 1/2 HP fan motor (1725 & 1140 RPM)
- Porcelain enamel interior oven
- Ten (10) position interior rack guides.
- Five (5) nickel plated oven racks.
- Fenawal electronic ignition.
- Electronic thermostat and manual timer controls.
- 150 F to 500 F temperature range (66 C to 260 C)
- Control panel located away from burners (right side) and opens downward for easy service.
- Two (2) Halogen interior lights.
- Oven ready light.
- Stainless Steel sides, front and top.
- Forced "cool down" fan mode control.
- One (1) year parts and labor warranty (only in Continental USA).
- Electrical: 120/60/1 HP, 6 ft. cord and 3 prong plug (NEMA#5-15P)



Model: IDCO-2 (w/ Mounting Kit included)

Model	Overall Dimensions			Oven Interior			Rack Clearance		Shipping Crate					List Price
	Width	Depth	Height	Width	Depth	Height	Width	Depth	Width	Depth	Height	Volume	Width	
IDCO-1	38.0"	30.5"	32.0"	29.0"	22.5"	28.25"	28.25"	22.0"	48.0"	42.0"	39.0"	45.5 cu.ft.	29.0"	\$9,590.00
	965mm	775 mm	813mm	737mm	572mm	508mm	718mm	559mm	1220mm	1067mm	991mm	1.30cu.ft.	737mm	
IDCO-2	38.0"	30.5"	70.0"	29.0"	22.5"	20.0"	22.5"	22.0"	48.0"	42.0"	80.0"	112 cu.ft.	29.0"	\$18,230.00
	965mm	775 mm	1778mm	737mm	572mm	508mm	572mm	559mm	1220mm	1067mm	2032mm	2.50cu.ft.	737mm	

Note: Set of (4) Legs with Casters for single Convection Oven Net \$175.00
 Set of (4) Heavy Duty Casters with kit for Double Stack Convection Oven, Net \$205

Gas: 3/4" NPT rear gas connection, specify type of gas and altitude if over 2,000 feet.
 Pressure: 5" W.C. - Natural Gas
 10" W.C. - Propane Gas
 Note: Install the pressure regulator supplied with the appliance, at the inlet of the gas line.



Ideal Cooking Products Vertical Broiler (AI Pastor Broiler) unique compact design offer an easy to fit product in any chef's kitchen to maximize space and satisfy the most demanding needs and assuring optimal performance and low operating and maintenance costs.

A unique design with upper double sided panels and heavy duty welded bottom griddle along with a high efficient infra-red burner complement these units' rough appearance.

Ideal Cooking Products Counter top Line-up align perfectly with other Ideal Products on height, depth and other design alike features such as bull noses and same valve alignment height among others.



Model: IDVB-18 (Gyro)



NSF/ANSI Std. 4

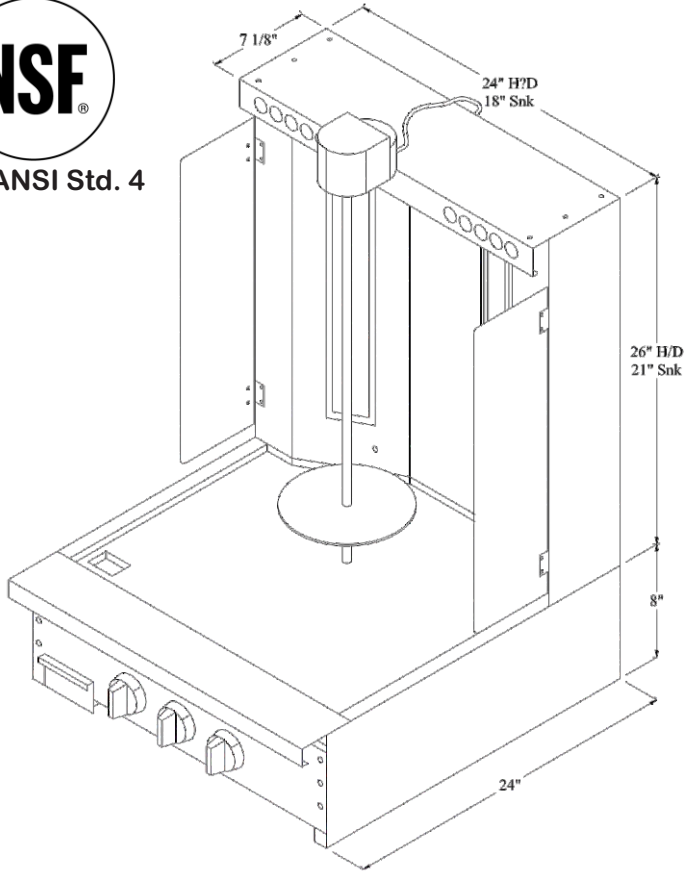

STANDARD FEATURES

- Heavy gage stainless steel top and exteriors.
- 1" upper double side panels for better insulation.
- 4" stainless steel bull nose provides large extra work space.
- Skewer holds up to 20 lbs. of meat for the snack line and up to 45 for the large one.
- Unique large capacity bottom griddle to warm tortillas or give an extra crispy appearance.
- Two efficient high BTU/hr Infra-red burners.
- Special design burner for bottom griddle.
- All three burners are controlled individually by a heavy duty knob.
- Large capacity removable grease can.
- Toggle switch turns motor on/off.
- Easy to load skewers on the units.
- Complies with "ANS Z83.11a-2004 / CSA 1.8-2004 Food Service Equipment".

Gas: 1/2" NPT rear gas connection, specify type of gas and altitude if over 2,000 feet.
 Pressure: 5" W.C. - Natural Gas
 10" W.C. - Propane Gas
 Note: Install the adequate pressure regulator at the inlet of the gas line.

Vertical Broilers (Gyro - Taco al Pastor)

Model	Dimensions	Weight	Total BTU's/hr	Price List	#s of Meat
IDVB-18	18"W x 24"D x 26"H	85 Lbs.	20,000	\$ 2,835.00	25 Aprox.
IDVB-21	21"W x 24"D x 28"H	105 Lbs	25,000	\$3,460.00	40 Aprox.
IDVB-24	24"W x 24"D x 32"H	135 Lbs	35,000	\$4,535.00	75 Aprox.



Ideal Cooking Products offers a great variety of commercial equipment to fulfill any chefs demands. Among our specialty equipment we build Chicken Broiler, Chicken Rotisseries, Teppan-Yaki Griddles, Mesquite Broilers (counter or cabinet base units), counter combination units (snack and heavy duty line), Flat Bottom Fryers, Step up Hot Plates and Stock Pots, Lowboy Ovens, Custom Ranges, Equipment Stands and any other challenging design.



Raised Grill (Argentinean Broiler)



Tamal Cart



Open Burner Prep-Table



Outdoor BBQ's



Custom Shish Kabob w/ Oven



Chicken Broiler



Jet Range Step up



Mesquite Wood Broiler



NSF Cart



Salad Bar Cart



Overfire Shish Kabaa Broiler

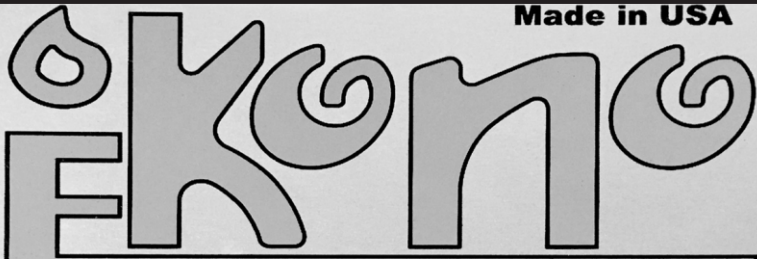

Made in USA

www.ekonocateringequipment.com



Food Trucks and Trailers

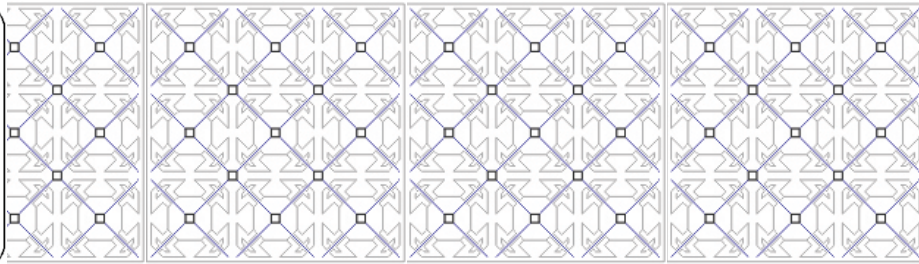

Terms

- **Prices:** Effective as June 01 / 2024 and subject to all applicable taxes.
- **FOB:** Azusa, CA 91702
- **Terms:** COD or Net 30 subject to credit approval.
- **Past Due:** 2% monthly plus service and interests.
- **Cancellations:** Specialty equipment should be advanced by a 50% of its price which it's not refundable, other equipment is subject to 30% re-stocking fee.
- **Returns:** Merchandise is subject to a 30% re-stocking fee plus the cost of repairs for reconditioning. All returns should be authorized by Ideal Cooking Products and requested in writing.
- **Shipping Liabilities:** Ideal Commercial Cooking Products, Inc. limits its responsibility to only loading the merchandise to the customer chosen freight. Shipping damages or equipment shortage shall be inspected and documented by the buyer promptly and must be advised on the delivery document. All damage claims should be directed and accompanied by the proper documentation and file immediately upon receipt. Customers have the right to refuse delivery if visible damage is sustained and delivery drivers are obliged to wait the necessary time for the adequate inspection of the equipment.
- **Specification:** Ideal Commercial Cooking Products, Inc. reserves the right to change its prices or specifications at any given time, without prior notice.
- Ideal Commercial Cooking Products, Inc. is not responsible for printing errors in pricing or specifications.

One Year Limited Warranty

- Ideal Commercial Cooking Products, Inc warrants its new products to be free from defects in material and workmanship for a period of one year from the date of installation, not to exceed 6 months from the date of shipment from our premises. Equipment sold and installed for other purposes of commercial use or outside the continental United States is excluded from this warranty.
- This warranty is limited to products sold to the original commercial user. The liability of Ideal Cooking Products is limited to the repair or replacement of any part to be warranted herein. Ideal Cooking Products shall bear the normal labor charges for repair or replacement to the extent that such performance is within 35 miles of an authorized service agency, and during regular straight hours. Travel outside 35 miles and any work performed at overtime or weekend rates will be the responsibility of the end user. Defective parts must be returned to Ideal Cooking Products, freight prepaid, for Warranty Inspection.
- Ideal Commercial Cooking Products, Inc assumes no obligation for products not installed properly in accordance with the instructions supplied with the equipment. Any alter or modified equipment is not covered under this warranty. Furthermore, Ideal Cooking Products assumes no obligation for any product which has been subject to misuse, abuse or harsh chemicals. Normal maintenance as outlined in the instructions is the responsibility of the customer and is not a part of this warranty.
- Most products are covered with a period of one year, parts and labor.
- Light bulbs, electrical components, porcelain parts and glass products are excluded from this warranty.
- Cast Iron Parts, if not alter chemically, have a 90 days warranty.
- This warranty is in lieu of any other agreement, expressed or implied, and constitutes the only warranty of Ideal Cooking Products with respect to their products. This states the exclusive remedy against Ideal Cooking Products and shall not be liable whether in contract or in tort or from any other legal liabilities, such as theory for loss of revenue or profit. Also including from arising out of warranties, representations, instruction, installation or defects from any cause, such as incidentals, indirect, special or consequential damages, or for any other loss or cost of similar type.
- Proper installation, initial check out, air shutter adjustments, or normal maintenance such as lubrication, adjustment or calibration of controls is the responsibility of the dealer, end user or installing contractor and it is not covered by this warranty.
- This warranty is only honored if the final buyer does send us back the warranty document issued within the unit in the first (10) ten days of the purchase, so we can register the sales date and/if additional information needed

V. 2024.1