

4 DECK SUPPORT SECTION
S0.3 1/2" = 1'-0"

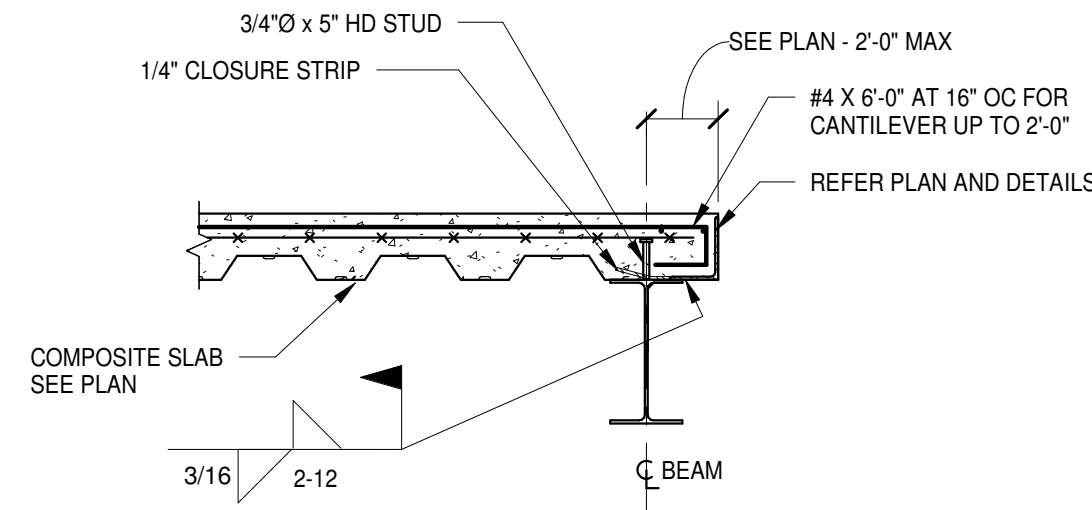

3 EDGE OF COMPOSITE DECK SECTION
S0.3 3/4" = 1'-0"

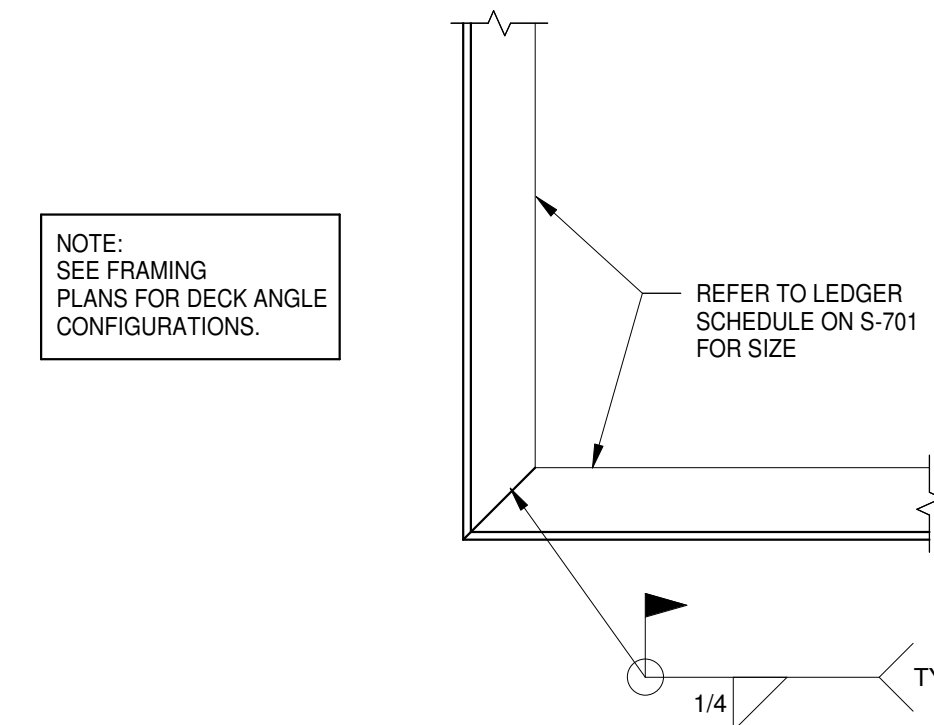

2 TYPICAL DECK ANGLE MITRED CORNER DETAIL
S0.3 3/4" = 1'-0"

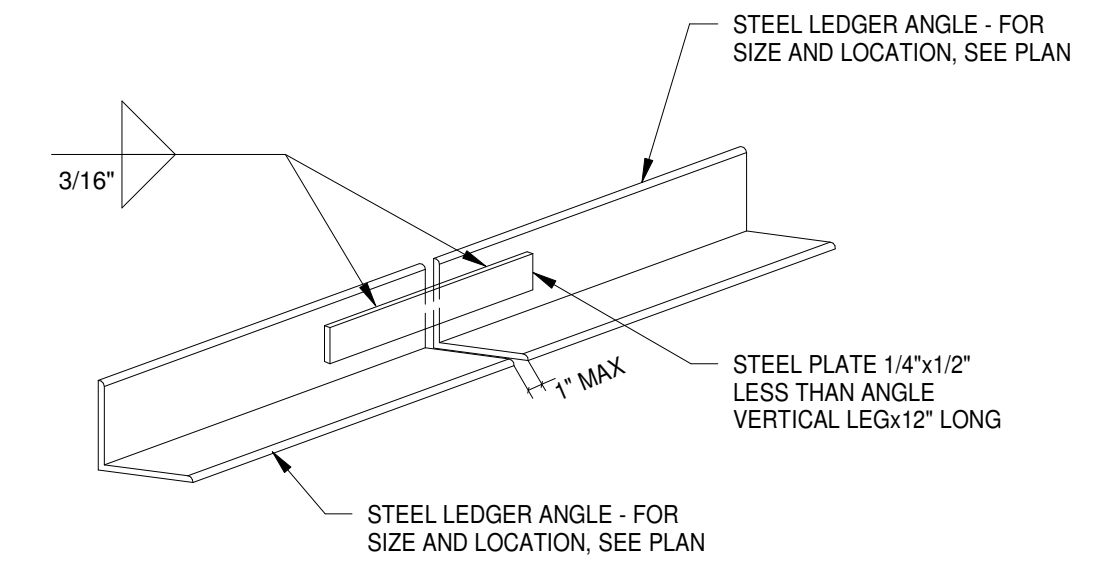

1 TYPICAL SPLICE IN CONTINUOUS STEEL LEDGER ANGLE
S0.3 3/4" = 1'-0"

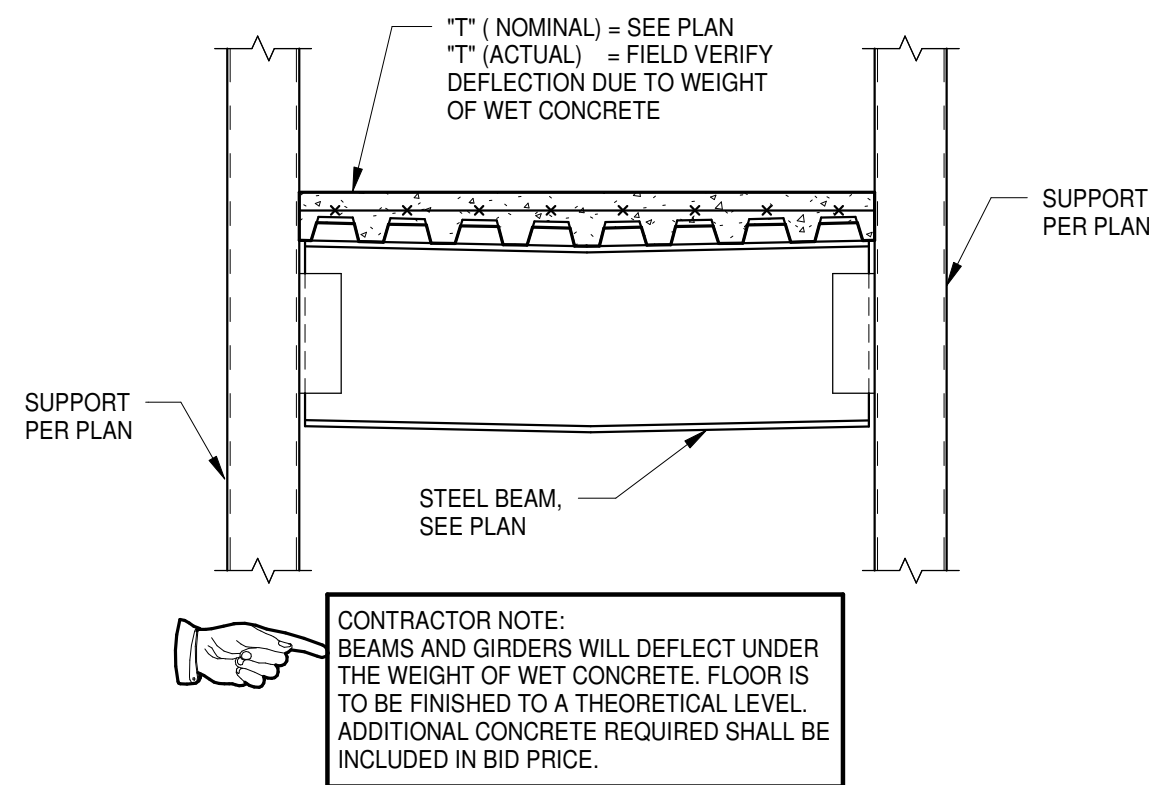

8 COMPOSITE SLAB FLOOR BEAM DEFLECTION DETAIL
S0.3 3/4" = 1'-0"

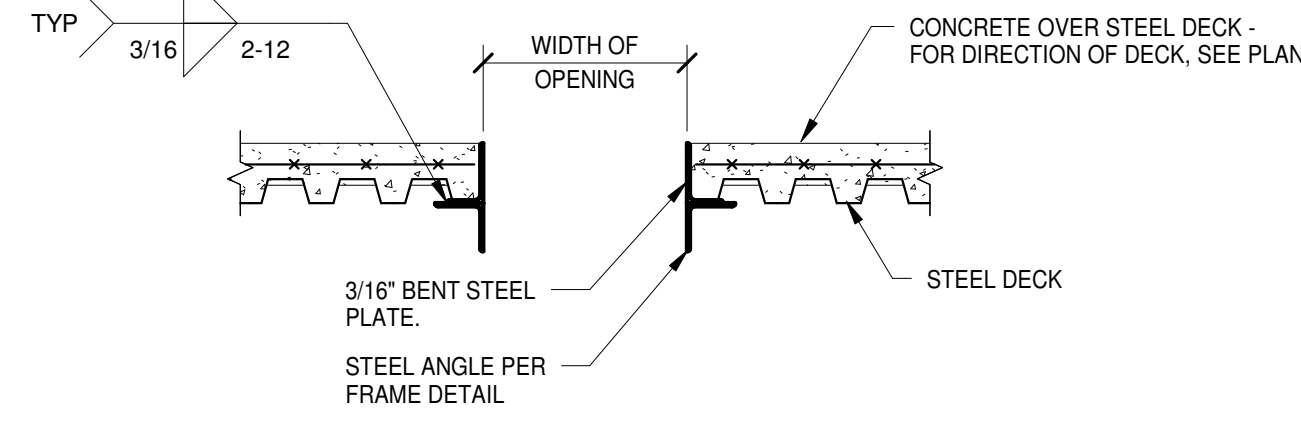

7 FRAMING AROUND OPENING IN STEEL DECK
S0.3 3/4" = 1'-0"

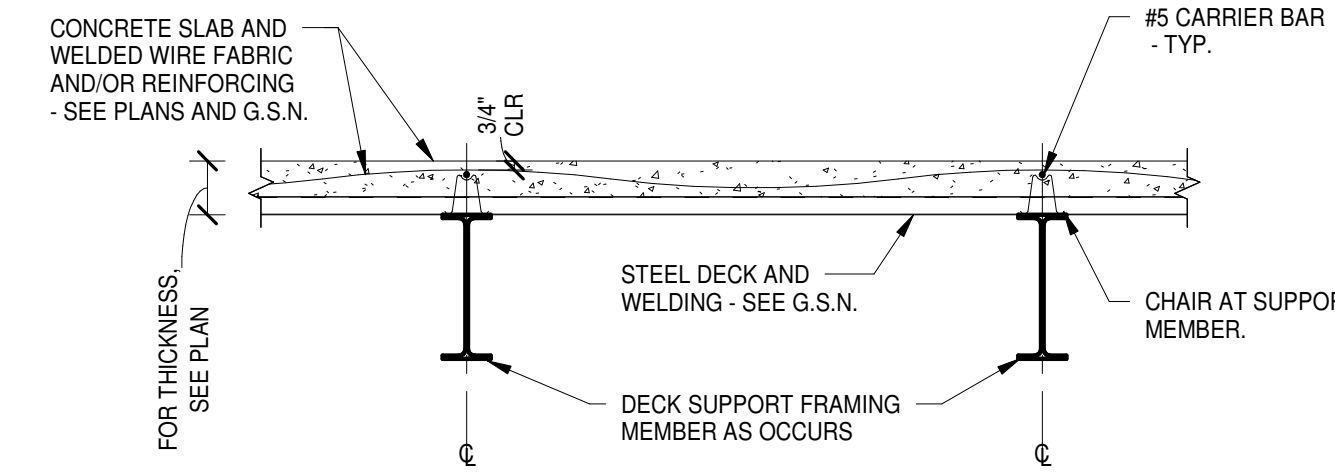

6 CONCRETE SLAB REINFORCING AT STEEL DECK
S0.3 3/4" = 1'-0"

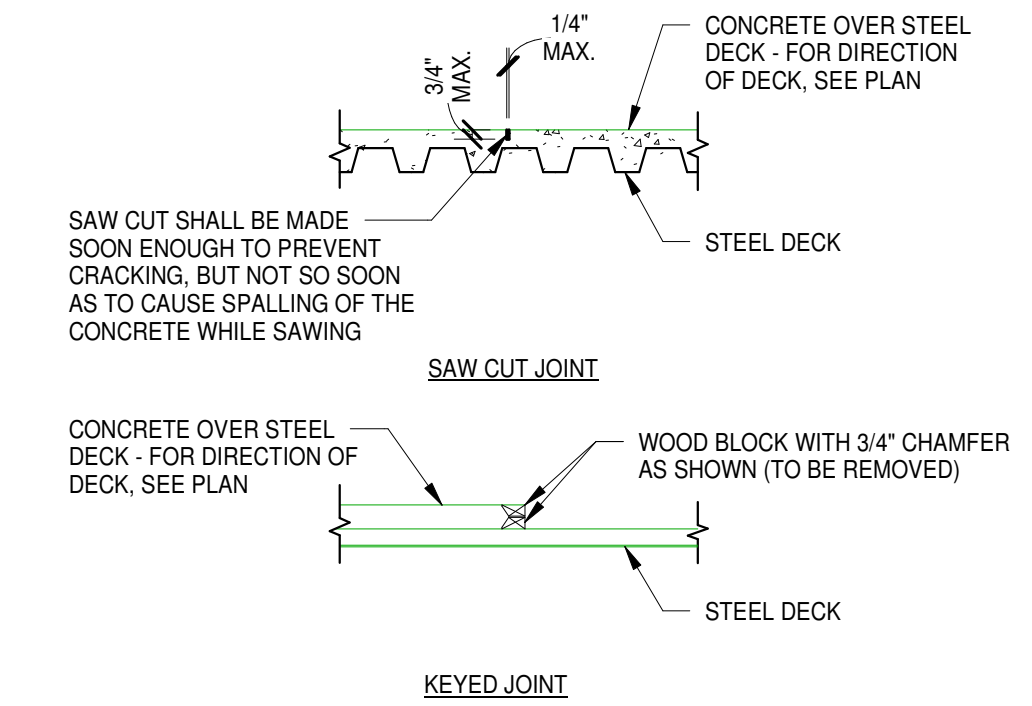

5 CONTROL JOINTS IN CONCRETE OVER STEEL DECK
S0.3 3/4" = 1'-0"

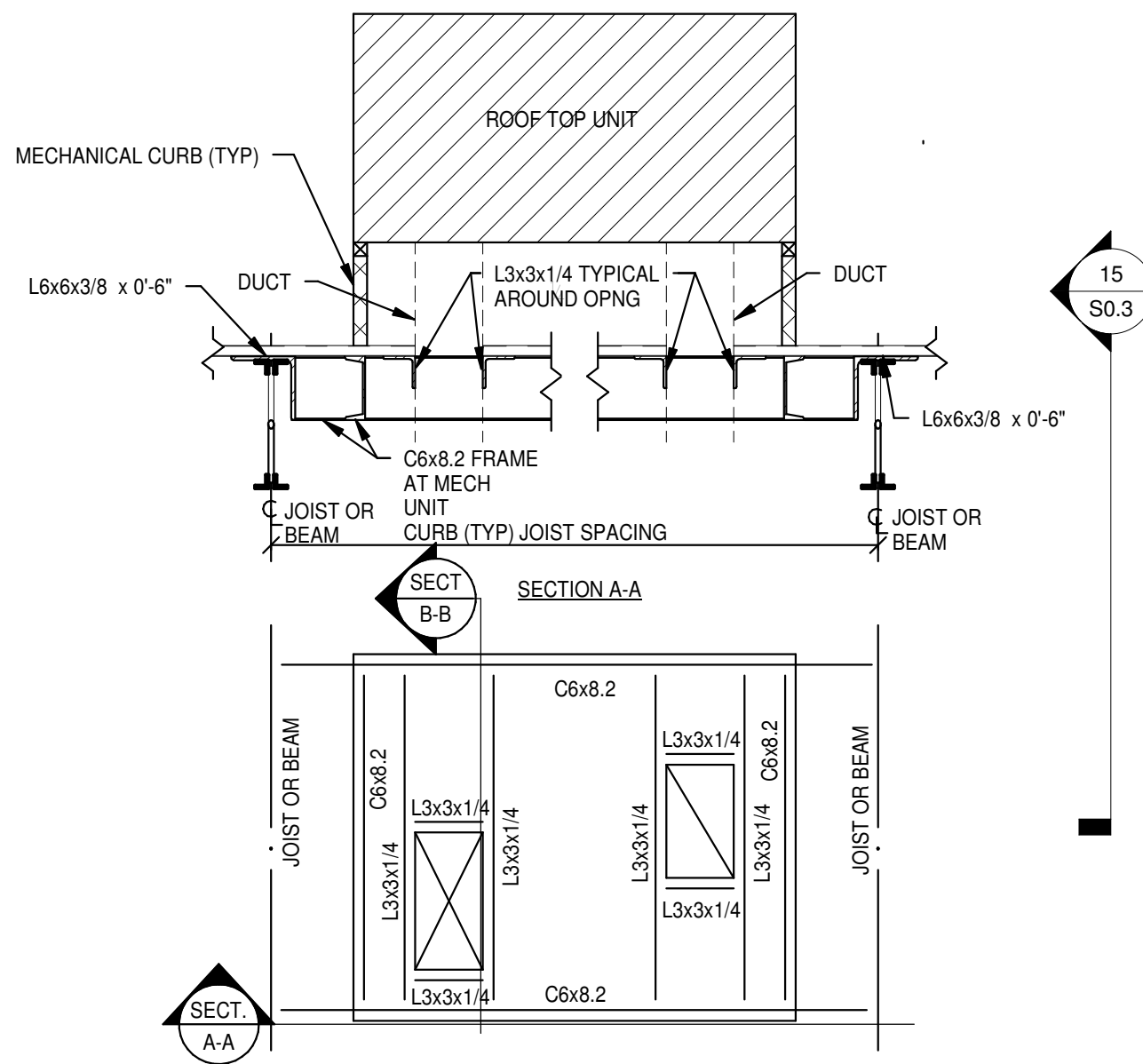

16 TYPICAL FRAMING ABOUT MECHANICAL UNIT
S0.3 3/4" = 1'-0"

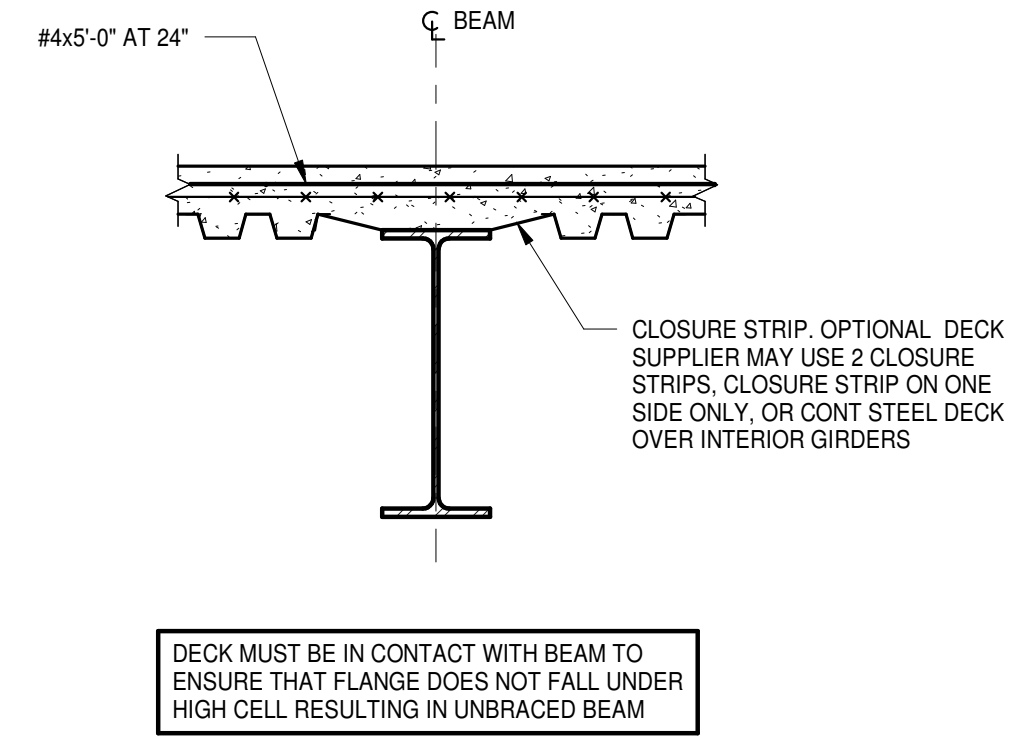

11 NON-COMPOSITE SLAB BEARING SECTION AT GIRDER
S0.3 3/4" = 1'-0"

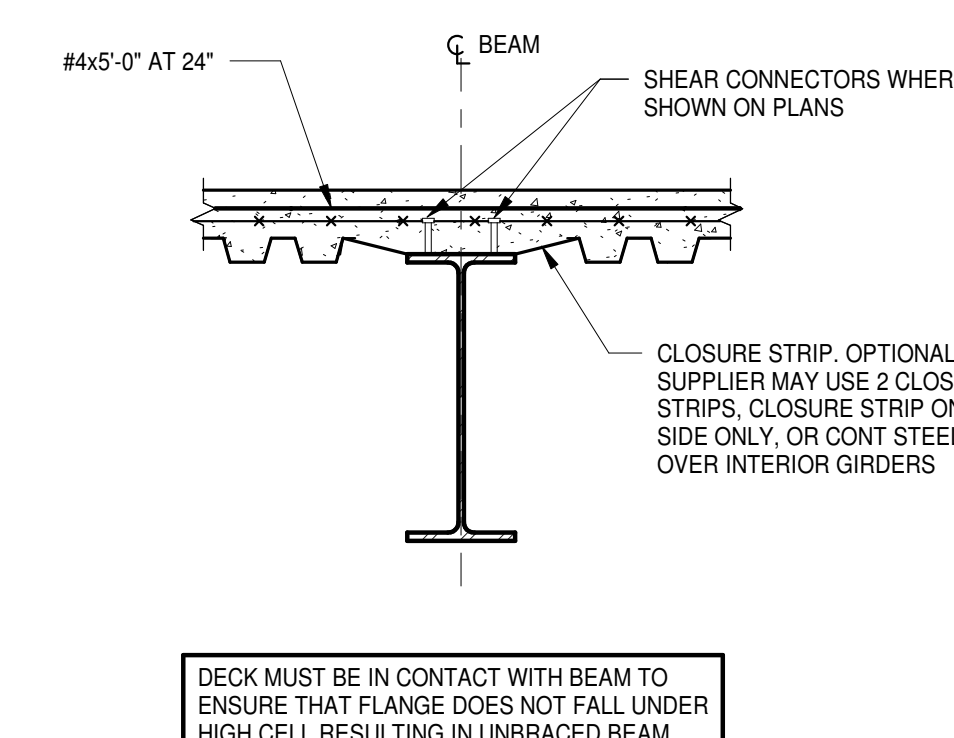

10 COMPOSITE SLAB BEARING SECTION AT GIRDER
S0.3 3/4" = 1'-0"

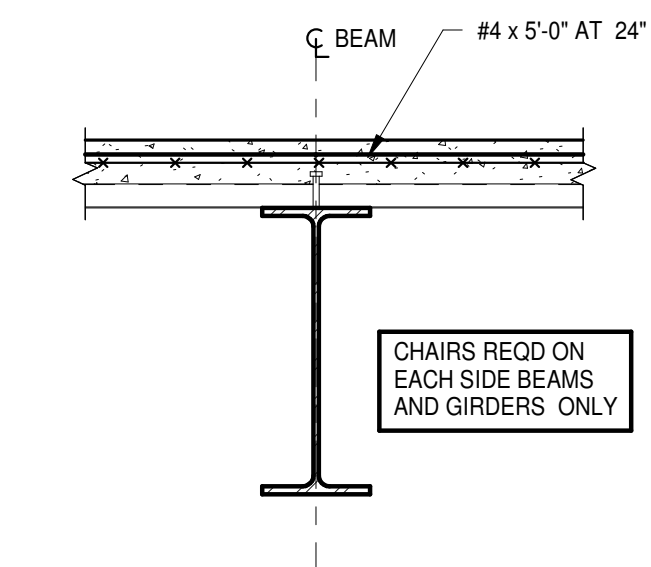

9 COMPOSITE SLAB BEARING SECTION AT STEEL BEAM GIRDERS
S0.3 3/4" = 1'-0"

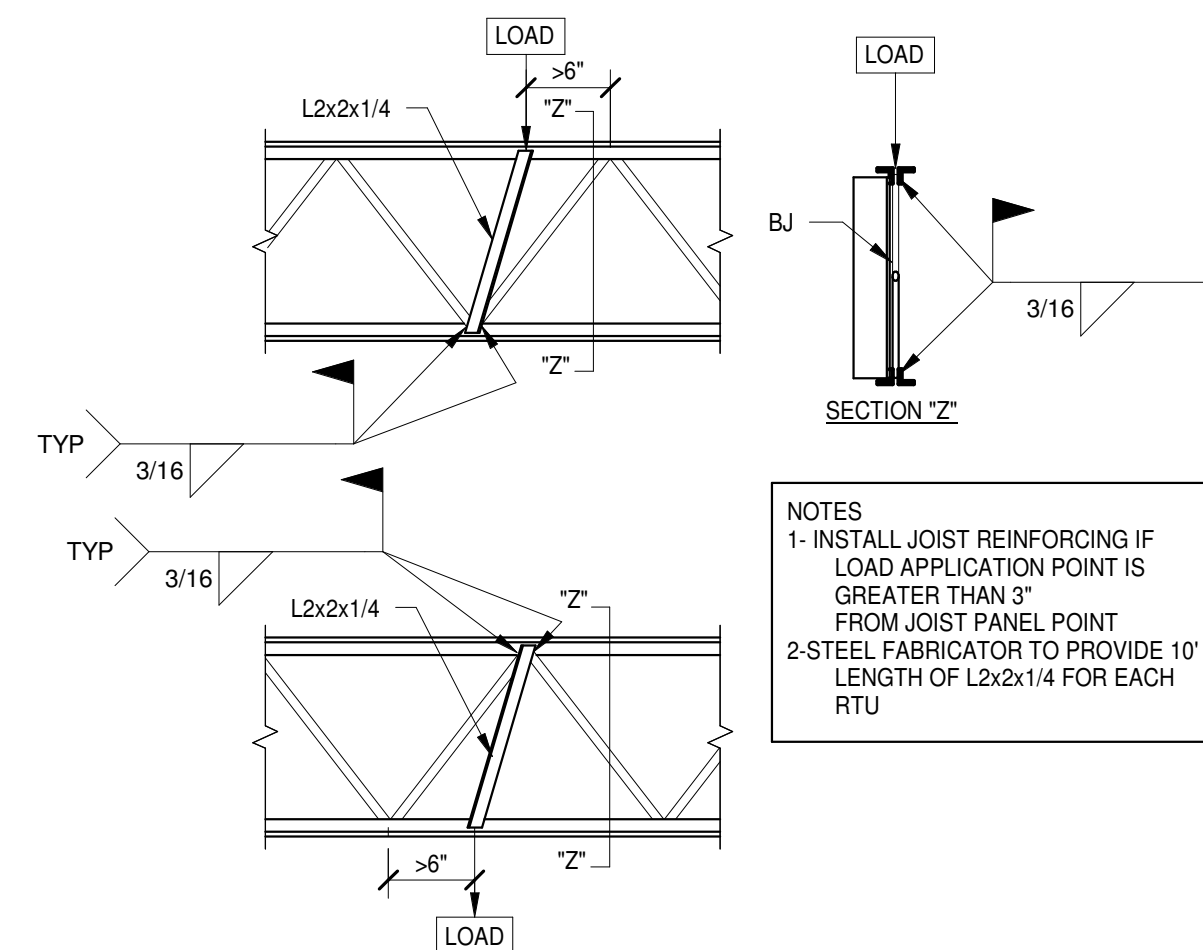

15 JOIST REINFORCING AT MECHANICAL UNITS
S0.3 3/4" = 1'-0"

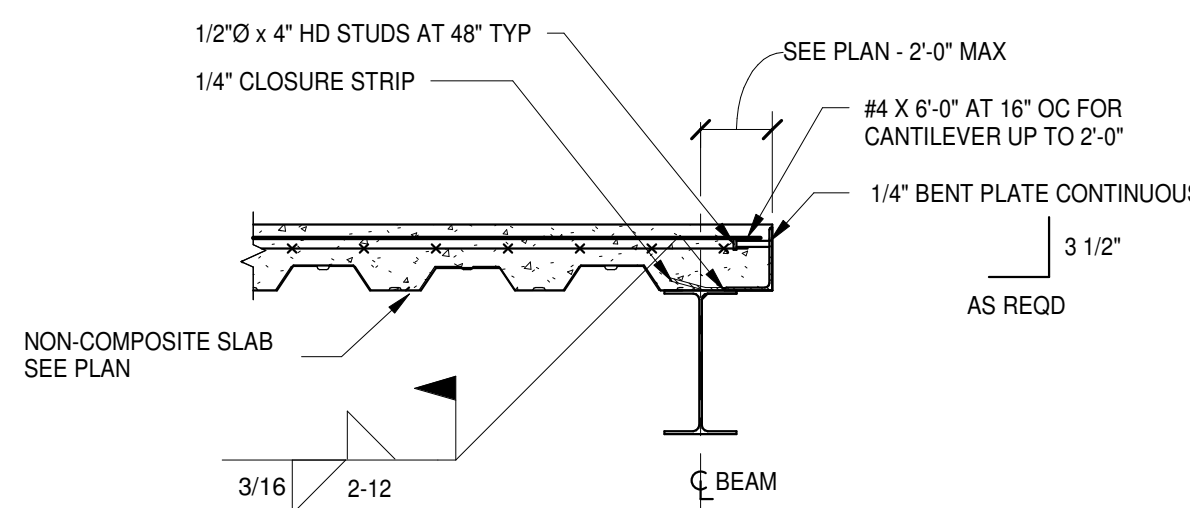

14 EDGE OF NON-COMPOSITE DECK SECTION
S0.3 3/4" = 1'-0"

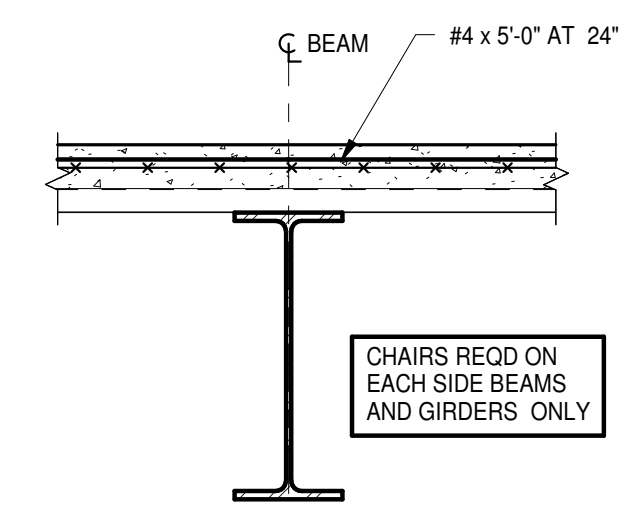

13 NON-COMPOSITE SLAB BEARING SECTION AT PURLINS
S0.3 3/4" = 1'-0"



RADHA KRISHNA TEMPLE
Owner
ALLEN TEXAS

JOB NUMBER: 16DLS003
ISSUE DATE: 04-22-2016
DRAWN BY: SDB
DESIGNED BY: NAV

NO.	REVISIONS

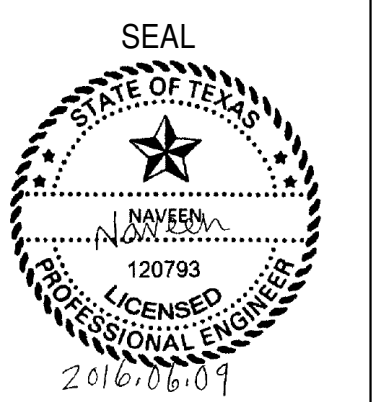

SHEET NUMBER
S0.3