

Industrial Drum Pump Packages

PUMP PACKAGE 8 Flammable & Combustible Liquids

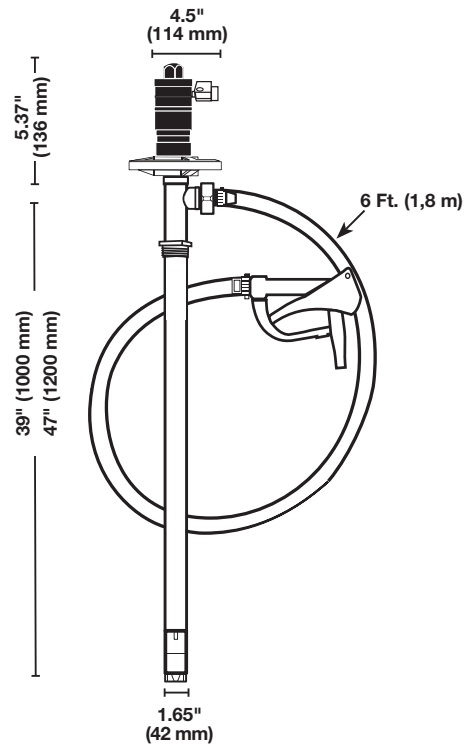

Technical Specifications

Package:Motor, Pump, Hose, Storage Bracket
 Barrel Adapter & Hand Nozzle
Air Inlet:.....1/8 NPT
Air Consumption:..... 22 CFM @ 90 psi
 (10.40 L/Sec @ 6,2 bar)
Maximum Inlet Pressure:..... 100 psi (6,8 bar)
Motor Type:.....Air
Pump Assembly:.....SS316
Pump Length:..... 39" (1000 mm) or 47" (1200 mm)
Discharge Hose:.....Solvent Hose, 6 ft (1,8 m), 1" (25 mm) I.D.
Hand Nozzle:..... SS316, 1" (25 mm)
Maximum Flow Rate:..... 17 GPM (64 LPM) *based on water*
Maximum Viscosity:..... 750 cps (mPas)
Maximum Temperature:.....175° F (80° C)
Shipping Weight:.....32 lbs. (14,5 kg)

Package Numbers:

Drums:

Pkg P/N	Motor	HP	Pump Tube
9604	SP-A1	1/2 HP (370 watts)	SP-SS-39
9605	SP-A2TL	3/4 HP (560 watts)	SP-SS-39

Tanks:

Pkg P/N	Motor	HP	Pump Tube
9606	SP-A1	1/2 HP (370 watts)	SP-SS-47
9607	SP-A2TL	3/4 HP (560 watts)	SP-SS-47

STANDARD
Pumps, Inc.

www.standardpump.com

Toll Free: 1-866-558-8611

Tel 770-307-1003