

Sustainable Coils LLC

Replacement Coil Solutions!

HORIZONTAL SLAB COILS

Revision Date: 02/02/2020

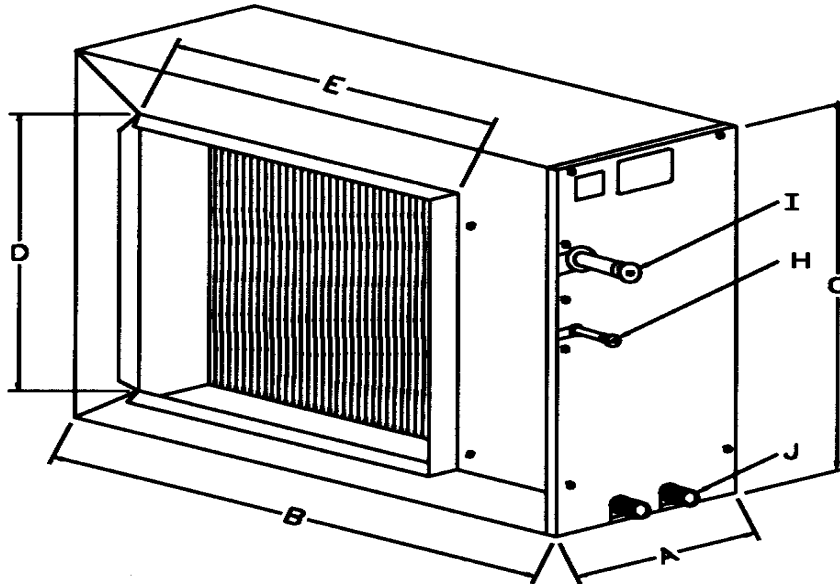

COIL MODEL	COIL WEIGHT	A	B	C	D	E	H	I	J
HS-24	37	10	20	25	21	14	3/8	3/4	3/4
HS-36	43	10	25	25	21	19	3/8	3/4	3/4
HS-48	49	10	30	25	21	24	3/8	7/8	3/4
HS-60	55	10	34	25	21	28	3/8	7/8	3/4

UNIGUARD® by Virtus Precision Tube, 3/8" O.D. 422 copper alloy tubing
 Aluminum end plates to protect against rust corrosion
 Louvered fins spaced at 14 FPI
 Piston metered for R-22 refrigerant, additional R-410A piston optional
 R-22 and R-410A expansion valve kits available upon request
 Metal drain pan
 Pre-swaged refrigerant connection, shipped with dry nitrogen holding charge
 Internal refrigerant volumes: HS24=96.29, HS36=130.68, HS48=165.07, HS60=192.59
 Five year replacement warranty

Visit our website at www.Sustainablecoils.com for further information regarding our complete product line.