



**Low Slope Roofing Systems**  
**The University of Wisconsin Madison**  
Madison, Wisconsin – December 1-2, 2020

**Roof decks and wind design**

presented by

**Mark S. Graham**  
Vice President, Technical Services  
National Roofing Contractors Association  
Rosemont, Illinois

1

**Definition**

*International Building Code, 2021 Edition*

**Roof deck:** The flat or sloped surface constructed on top of the *exterior walls* of a building or other supports for the purpose of enclosing the *story* below, or shelter an area, to protect it from the elements, not including its supporting members or vertical supports



2

2



3

### A roof deck....

- is a building's structural component of the roof assembly
- must be capable of safely supporting the design dead and live loads, including the weight of the roof system, and any additional loads that may be required by the applicable building code
- also provides the substrate to which roof systems are applied
- are categorized as either noncombustible (steel, concrete) or combustible (plywood, OSB, wood planks, wood boards)
- can also be categorized as "nailable" (attachment) or "non-nailable" (adhesion)

THE UNIVERSITY OF WISCONSIN

4

## Types of roof decks

- Cementitious wood fiber panels
- Lightweight insulating concrete
- Steel
- Structural concrete (cast-in-place, precast-prestressed and post-tensioned)
- Wood panels (plywood, OSB)
- Wood planks and wood boards



5

5

## Cementitious wood fiber panels



- Noncombustible
- Nailable
- Available as a composite product with rigid board insulation
- NRDC 600, "Guidelines for the Application of Cementitious Wood Fiber Roof Deck Systems ([Link](#))"



6

6

## Lightweight insulating concrete



- Noncombustible
- Nailable
- Poured in place
- Two types:
  - Lightweight aggregate
  - Lightweight cellular
- NRDCA 100: aggregate ([Link](#))
- NRDCA 175: cellular ([Link](#))
- Drying & venting considerations



7

## Cross section view

Lightweight insulating concrete

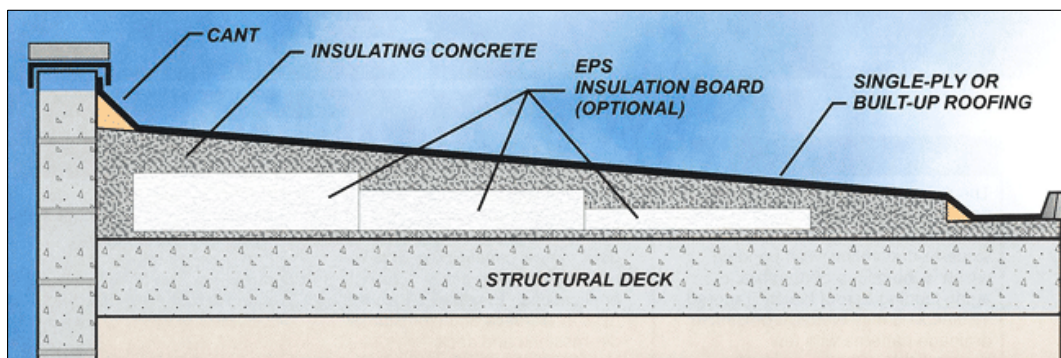

8

### Steel roof deck

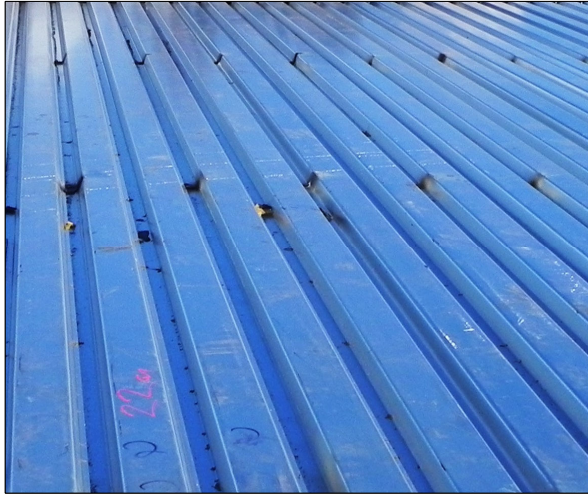

- Noncombustible
- Mechanical fasteners
- Multiple profiles/spans
- Prime painted and galvanized
- Two strength types:
  - 33 KSI
  - 80 KSI
- SDI RD-100, “Steel Roof Deck”



9

### Steel roof deck -- continued

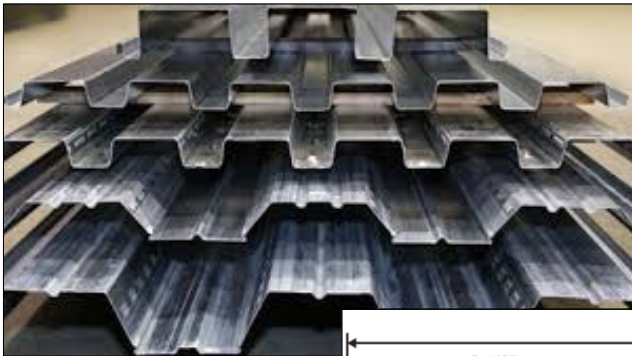

Steel roof deck configurations

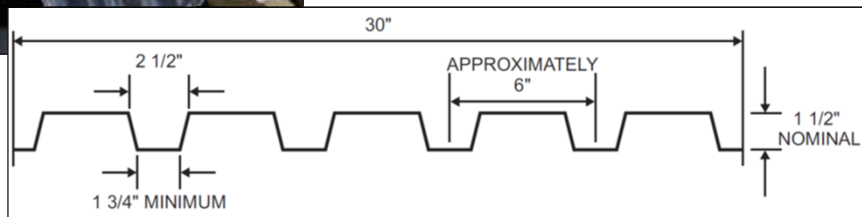

Wide-rib steel roof deck (Type B)



10

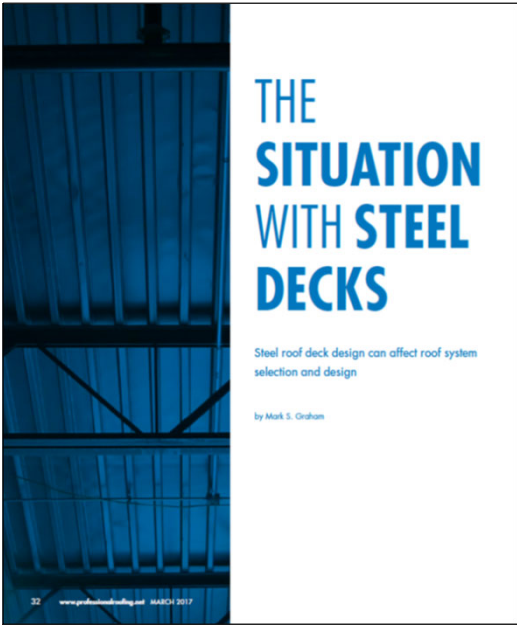

**Professional Roofing**  
March 2017

[Link](#)

11

11

### Structural concrete



- Noncombustible
- Non-nailable
- Composition types:
  - Normal weight (150 lbs./ft<sup>3</sup>)
  - Lightweight (90-110 lbs./ft<sup>3</sup>)
- Construction types:
  - Cast-in-place (incl. post tensioned)
  - Precast-prestressed
- Curing and drying considerations

12

12



## Structural concrete -- continued

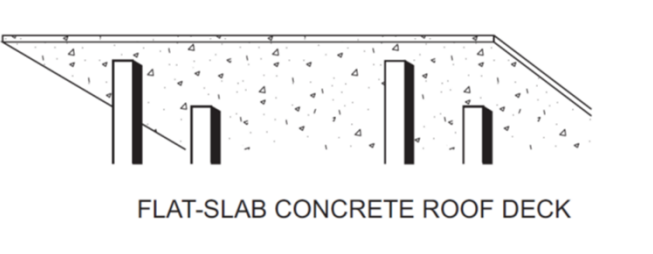

FLAT-SLAB CONCRETE ROOF DECK

Cast-in-place concrete roof deck

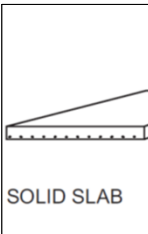

SOLID SLAB

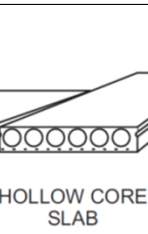

HOLLOW CORE SLAB



DOUBLE TEE

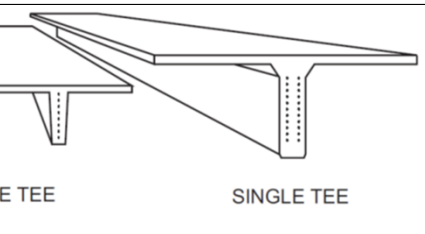

SINGLE TEE

Precast concrete units



13

13

**Concerns with Concrete Roof Decks / Moisture Release Present Challenges**  
**by Mark S. Graham, Vice President, Technical Services, National Roofing Contractors Association (NRCA)**

Newly poured and, in some instances, existing structural concrete roof decks present unique moisture migration problems for the roofing industry. In a number of instances reported to NRCA, significant amounts of water have been found in roof systems within as soon as several months after construction. In most of these situations, it was determined the roof membranes were watertight and not the sources of the moisture infiltration. In many of these situations, this moisture infiltration resulted in damage to the roof systems, including adhesion loss, issues with water-based and low-VOC adhesives, metal and fastener corrosion, insulation R-value loss and microbial growth.

**Concrete basics and dryness**  
 When mixed, poured and formed, normal-weight and lightweight structural concrete contain significant amounts of water. As concrete cures and hardens, it consumes large amounts of water through hydration and evaporation. For example, a 4-inch-thick concrete slab will release about 1 quart of water for each square foot of its surface area.

Previously, the roofing industry had used a minimum 28-day drying period as a guideline for applying roofing materials over newly poured concrete decks. This 28-day period coincided with the curing time of concrete before it is tested for design compressive strength. In reality, there is little to no correlation between this 28-day period and concrete's true "dryness."

Similar to the roofing industry, the concrete industry has seen significant advances in technology regarding concrete mix design, placement and curing. For example, the use of admixtures in concrete mix designs can accelerate concrete's curing and strength development but retard the release of concrete's free moisture. Similarly, weather conditions, covering newly poured concrete, timing of form removal, and temporary heating or ventilating of a building's interior after placement can affect concrete's upward or downward release of free moisture.

## Concerns with concrete roof decks: Moisture release present challenges

June 2020

[Link](#)

14

14

### Plywood and OSB panels



- Combustible
- Nailable
- Thickness and span
- Standards:
  - PS 1: Plywood
  - PS 2: OSB
  - APA PRP-108: Plywood or OSB
- APA Engineered Wood Construction Guide (E30): Roof Construction ([Link](#))



15

15

### Wood plank and wood boards



- Combustible
- Nailable
- Wood planks: 2-5 inches thick with straight edges or T & G
- Wood boards: Less than 2 inches thick with square edges
- Species, thickness and span
- American Timber Council (ATC) *Timber Construction Manual*



16

16



## **Other roof deck types**

Sometimes encountered in reroofing

- Gypsum
  - Poured in place
  - Panels
- Thermal-setting fills
- Tile or masonry
- Various fills:
  - “Actinolite”
- Various composites
  - “Loadmaster”



17

17

## **Additional considerations**

Roof decks

- Deflection and smoothness
- Slope to drain
- Temporary weather protection
- Structural expansion joints & roof control joints
- Construction loading
- Deck “acceptance”



18

18

**A Roofing Contractor’s “acceptance”  
of a roof deck should be limited to:**

- Cleanliness: Broom clean (maybe leaf-blower clean)
- No visible surface moisture

*Any additional acceptance criteria is likely  
beyond a roofing contractor’s expertise*



19

19

**Questions**

Roof decks



20

20



## Wind design

21

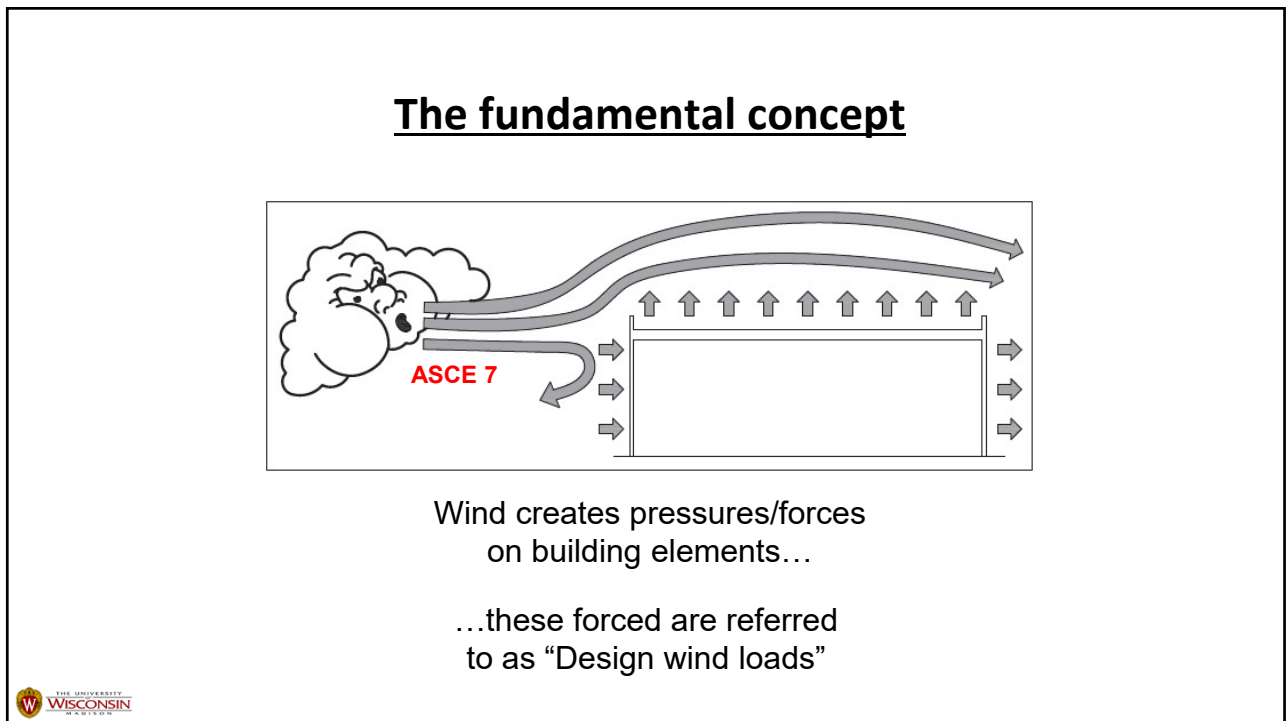

22

## The fundamental concept -- continued

A roof system needs to be able to “resist” the design wind loads acting on a building.

- Roof systems are tested for their “resistance” (attachment, adhesion):
  - FM Approvals classifications (FM 1-60, 1-90, 1-120, etc.)
  - UL classifications (UL Class 30, 60, 90)
  - Engineering analysis



23

23

## The fundamental concept -- continued

Design wind loads  $\leq$  Tested resistance\*

ACE 7-16  $\leq$  FM Approvals classification or  
UL classification\* or  
Engineering analysis\*

- \* A “safety factor”, typically 2.0 (i.e., 1/2 of tested resistance), is applied to account for variations in designs, materials, application and roof system aging/deterioration.



24

24

### Design wind loads

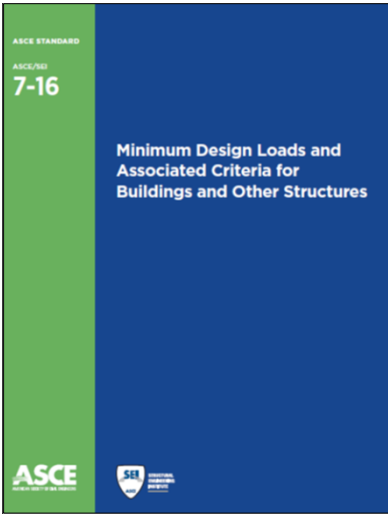

**ASCE 7-16, “Minimum Design Loads and Associated Criteria for Buildings and Other Structures”**

25

### Roof zones

For buildings up to 60 high

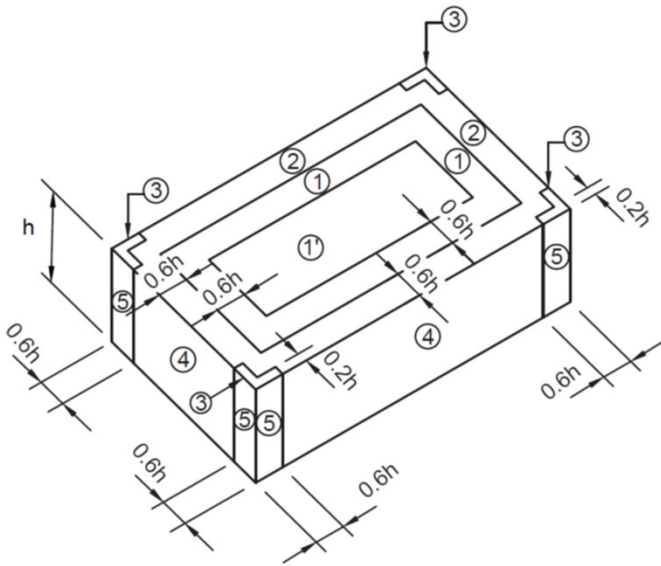

**Pressure coefficients (ASCE 7-16)**

- Zone 1': 0.9
- Zone 1: 1.7
- Zone 2: 2.3
- Zone 3: 3.2

26

### Roof zones -- continued

For buildings greater than 60 high

**Pressure coefficients**

- Zone 1: 1.7
- Zone 2: 2.3
- Zone 3: 3.2

a = 10% of the least horizontal dimension, or 0.4 times the building height, whichever is smaller; but not less than either 4% of the least horizontal Dimension or 3 feet

27

### Example design wind load calculation using ASCE 7-16

**Example:** A low-rise office building (Risk Category II) is located in Madison, WI. The building is an enclosed structure with a mean roof height of 60 ft. The building is located in an open terrain area that can be categorized as Exposure Category C.

Document	Basic wind speed (mph)	Design wind pressure (psf)			
		Zone 1' (Center)	Zone 1 (Field)	Zone 2 (Perimeter)	Zone 3 (Corners)
ASCE 7-16 Ult.	$V_{ULT} = 105$	29.5	51.2	67.6	92.0
ASCE 7-16 ASD	$V_{ASD} = 90$	17.7	30.7	40.5	55.2

28



### Example design wind load calculation using ASCE 7-16

**Example:** A low-rise office building (Risk Category II) is in Madison, WI. The building is an enclosed structure with a mean roof height of 60 ft. The building is in an open terrain area that can be categorized as Exposure Category C.

Document	Basic wind speed (mph)	Design wind pressure (psf)			
		Zone 1' (Center)	Zone 1 (Field)	Zone 2 (Perimeter)	Zone 3 (Corners)
ASCE 7-16 Ult.	$V_{ULT} = 105$	29.5	51.2	67.6	92.0
ASCE 7-16 ASD	$V_{ASD} = 90$	17.7	30.7	40.5	55.2

An FM 1-75 classification provides adequate resistance



29

### Considerations/Reminders

- Design wind loads should be determined by the building/roof assembly designer
- Taller buildings, higher wind pressures
- Increasing basic wind speeds, higher wind pressures
- Don't confuse (basic) wind speeds, with pressures:
  - For example, FM 1-90 means 45 psf, not 90 mph
- Proper wind design is relatively complicated



30

30

## Roof Wind Designer

www.roofwinddesigner.com

**roofwinddesigner.com**

ASCE 7-05, ASCE 7-10 and ASCE 7-16

Home | Contact Us | FAQ Welcome: **Mark Graham** | My Projects | Profile | Logout | Administration

Roof Wind Designer is intended to provide users with an easy-to-use means for determining roof systems' design wind loads for many commonly encountered building types that are subject to building code compliance.

Design-wind loads are derived using the American Society of Civil Engineers (ASCE) Standard ASCE 7, "Minimum Design Loads for Buildings and Other Structures." This standard is a widely recognized consensus standard and is referenced in and serves as the technical basis for wind load determination in the International Building Code and NFPA 5000: Building Construction and Safety Code. Roof Wind Designer allows users to choose between ASCE 7's 2005, 2010, and 2016 editions. Roof Wind Designer uses ASCE 7-05's Method 1—Simplified Method, ASCE 7-10's Envelope Procedure, Part 2: Low-rise Buildings (Simplified) of Chapter 30, ASCE 7-16's Envelope Procedure, Part 2: Low-rise Buildings (Simplified) of Chapter 30, and Part 4: Buildings with  $60\text{ft} < h \leq 160\text{ft}$  (Simplified). For a more detailed explanation of ASCE 7's three editions, please [click here](#).

Also, Roof Wind Designer determines roof systems' minimum recommended design wind-resistance loads, which are derived from the building's design wind loads, taking into consideration a safety factor in reliance of [ASTM D6630](#), "Standard Guide for Low Slope Insulated Roof Membrane Assembly Performance," [AISI S100](#), "North American Specification for the Design of Cold-formed Steel Structural Members" and [AA ADM1](#), "Aluminum Design Manual: Part 1-A—Specification for Aluminum Structures, Allowable Stress Design; and Part 1-B—Aluminum Structures, Load and Resistance Factor Design." Using these minimum recommended design wind-resistance loads, users can select appropriate wind resistance classified roof systems.

Edge-metal flashing systems take into consideration a safety factor in reliance of [ANSI/SPR1ES-1](#) "Test Standard for Edge Systems Used with Low Slope Roofing Systems."

Roof Wind Designer has been developed and is maintained by the National Roofing Contractors Association (NRCA), with initial support of the Midwest Roofing Contractors Association (MRCA) and the North/East Roofing Contractors Association (NERCA). The application is currently available at no cost.

Questions regarding Roof Wind Designer can be directed to the [Contact Us](#) page.

To register for a new account [click here](#). If you already have an account, [click here](#) to login.

31

31

## UL Product iQ

www.productiq.ulprospector.com

### Search UL Certification Information

× Search

GET STARTED

### Search Tips



Search Database



Review Results



Certification Information

32

32

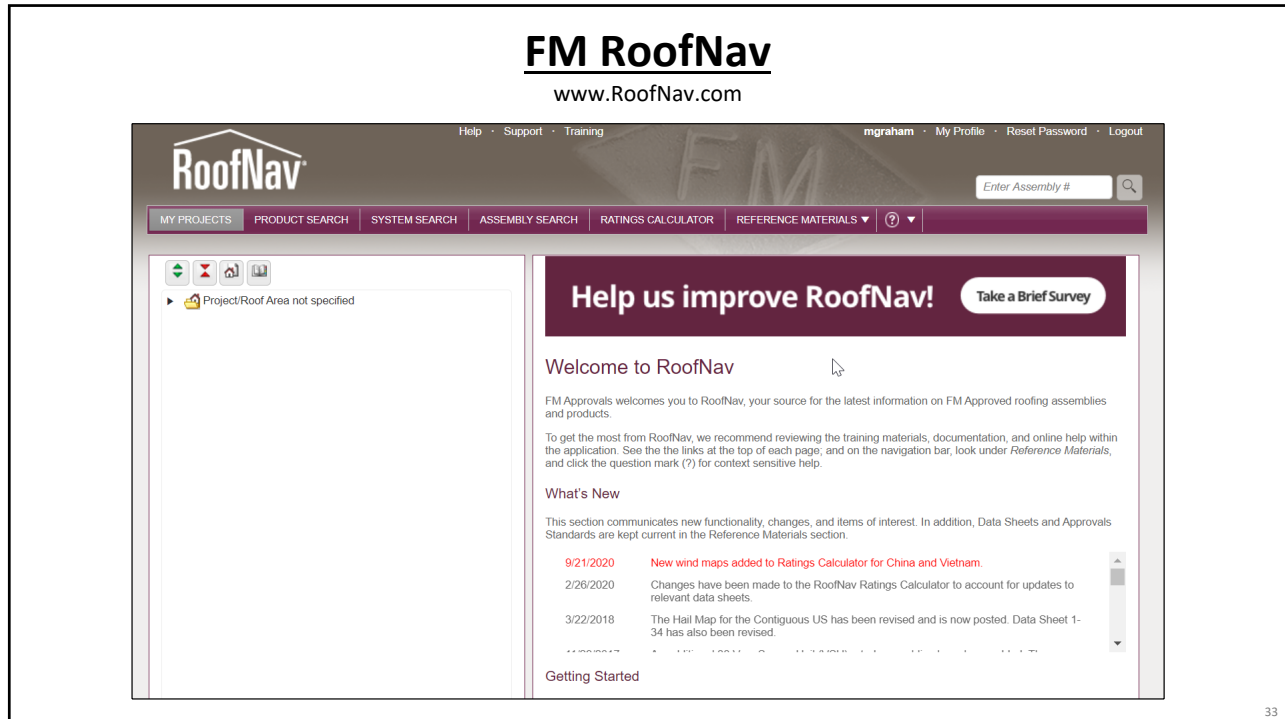

33

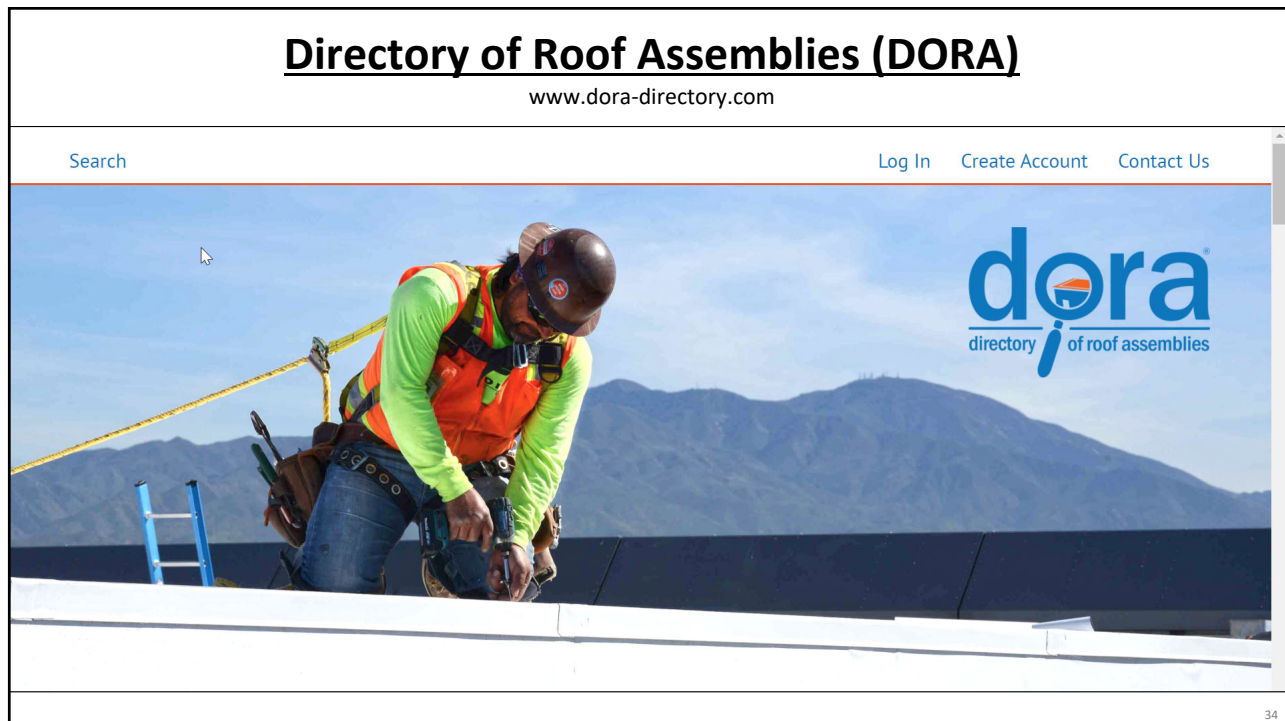

34

# FM Global Loss Prevention Data Sheets

www.FMGlobalDataSheets.com

**FM Global Property Loss Prevention Data Sheets 1-28**  
October 2015  
Interim Revision October 2020  
Page 1 of 100

**WIND DESIGN**

**Table of Contents**

	Page
1.0 SCOPE	5
1.1 Changes	5
1.2 Hazard	5
2.0 LOSS PREVENTION RECOMMENDATIONS	6
2.1 Design Wind Pressures	6
2.2 Eave/Overhang	6
2.3 Section Reserved for Future Use	8
2.4 Opening Protection in Exterior Walls	8
2.4.1 Exterior Doors	8
2.4.2 Windows in Exterior Walls	8
2.4.3 Louvers in Exterior Walls	8
2.5 Roof-Level Equipment and Surfacing	11
2.6 Wind Tunnel Tests	12
2.8 Use of the Eurocodes	13
2.9 Emergency Power Systems	13
2.10 Wind Emergency Procedures	14
3.0 SUPPORT FOR RECOMMENDATIONS	14
3.1 Wind Forces	14
3.1.2 Design Wind Speeds	14
3.1.3 Enhanced Designs for Regions Prone to Tropical Storms Including Hurricanes, Typhoons and Cyclones	15
3.2 Wind Pressure Determination	16
3.2.1 Calculating Basic Wind Pressure	16
3.2.2 Wind Zones of Buildings	17
3.2.3 Determining Surface Roughness Exposure	20
3.2.4 Building Enclosure Classification	20
3.2.5 Topographic Factor (K <sub>t</sub> )	20
3.2.6 Velocity Pressure Coefficient (K <sub>d</sub> )	20
3.2.7 Insulation Factor	20
3.3 Section Reserved for Future Use	20
3.4 Wind Design Pressures for Less-Common Roof Shapes	20
3.4.1 Steep-Slope, Mono-Slope, and Shed Roofs	20
3.4.2 Steep-Slope Low-Slope Roofs	20
3.4.3 Arched Roofs	20
3.4.4 Dome Roofs	20
3.4.5 Shed-Slope Multi-Slope Gabled Roofs	20
3.4.6 Gabled Roofs with Slopes Greater Than 45°	20
3.5 Wind Ratings for FM Approved Roof and Wall Assemblies	20
3.5.1 FM Approved Roof Assemblies	20
3.5.2 FM Approved Exterior Wall Assemblies	20
3.5.3 Windborne Debris Ratings	20
3.6 FM Approved Exterior Wind and Roof-Hat Straps	20
3.7 Designing for Windborne Debris	20
3.7.1 Designing for Small Windborne Debris	20

## FM 1-28, Wind Design

### Design wind load determination

35

35

# FM Global Loss Prevention Data Sheets

www.FMGlobalDataSheets.com

**FM Global Property Loss Prevention Data Sheets 1-29**  
January 2016  
Interim Revision February 2020  
Page 1 of 50

**ROOF DECK SECUREMENT AND ABOVE-DECK ROOF COMPONENTS**

**Table of Contents**

	Page
1.0 SCOPE	3
1.1 Changes	3
2.0 LOSS PREVENTION RECOMMENDATIONS	3
2.1 Introduction	3
2.2 Construction and Location	4
2.3 General Design Recommendations and Material Selection	4
2.3.1 Structural Concrete Roof Deck	5
2.3.2 Fiberglass Reinforced Plastic (FRP) Insulated Roof Deck Assemblies	5
2.3.3 Concrete Panel Roof Deck	5
2.3.4 Insular and Hybrid Deck	5
2.3.5 Fire-Retarded Treated Lumber and Plywood	5
2.3.6 Light-gauge Standing Corrugated (SLC) and Form Deck	5
2.3.7 Above-Deck Roof Components (Other Than LWIC)	5
2.3.8 Inspection, Testing, and Maintenance	5
2.3.9 Above-Deck Roof Components (Other Than LWIC)	5
3.0 SUPPORT FOR RECOMMENDATIONS	35
3.1 Supplemental Information	35
3.1.1 Class 1 and Class 2 Roof Decks	35
3.1.2 Wind Uplift Resistance: Non-Balanced Roof Covers	35
3.1.3 Wind Uplift Resistance: Balanced Systems	37
3.1.4 External Conductivity	38
3.1.5 Ra-Cover Construction	38
3.1.6 Wind Uplift	38
3.1.7 Wind Damage	40
3.1.8 Interior Construction	40
3.1.9 Steel Deck and Eurocode Examples	40
4.0 REFERENCES	42
4.1 FM Documents	42
4.2 Others	42
APPENDIX A: GLOSSARY OF TERMS	43
APPENDIX B: DOCUMENT REVISION HISTORY	45
APPENDIX C: SUPPLEMENTAL INFORMATION FOR PROPRIETARY PROTECTED MEMBRANE ROOF SYSTEMS	45
C.1 Insulation Fastener Placement	45

## FM 1-29, Roof Deck Securement and Above-deck Roof Components Resistance

36

36

### Comparing ASCE 7-16's design wind loads to FM 1-28's

**Example:** A low-rise office building (Risk Category II) is in Madison, WI. The building is an enclosed structure with a mean roof height of 60 ft. The building is in an open terrain area that can be categorized as Exposure Category C.

Document	Basic wind speed (mph)	Design wind pressure (psf)			
		Zone 1' (Center)	Zone 1 (Field)	Zone 2 (Perimeter)	Zone 3 (Corners)
ASCE 7-16 Ult.	$V_{ULT} = 105$	29.5	51.2	67.6	92.0
ASCE 7-16 ASD	$V_{ASD} = 90$	17.7	30.7	40.5	55.2
FM 1-28	$V_{ASD} = 90$	24	43	57	77

FM 1-90



37

## Questions

Roof decks



38



**Mark S. Graham**

Vice President, Technical Services  
National Roofing Contractors Association  
10255 West Higgins Road, 600  
Rosemont, Illinois 60018-5607

(847) 299-9070  
mgraham@nrca.net  
www.nrca.net

Personal website: [www.MarkGrahamNRCA.com](http://www.MarkGrahamNRCA.com)