

Multiple Applications



**Water Management Solutions, Inc.**

Going the extra mile starts here!™

**GLOBAL PUMP**  
A MERSINO COMPANY

## 8GST Standard Trash Pump



At WMS, we pride ourselves in being able to offer multiple options for our customers, including the Global Pump® Standard Trash pumps. They are specifically designed to effectively handle a wide range of liquids from water to sewage and sludge that can contain solids and other materials. The Standard Trash pump provides a dependable and highly efficient solution. The model 8GST is capable of achieving maximum flows of 3,650 gpm (829 m<sup>3</sup>/h) and a maximum total head of 183' (55.8m) while handling solids up to 4" (101.6mm) in diameter. The 8GST is powered by a water-cooled, 4 cylinder diesel engine. Add our 24/7 service plan to your rental and you are guaranteed a hassle-free experience. Call us today!

Construction  
Dewatering

Sewage Bypass

Flood Drainage

Mining/Quarries

Municipal

General Industrial

### Features

- Engineered for portable application
- Non-return valves uses only a single moving part to allow with minimal restriction
- Standard engine control panel provides preset emergency shutdown protection and allows the addition of automatic level control
- Fully guarded coupling
- Pump casings are hydrostatically tested to 50 psig (345 kPa) above the peak casing design pressure
- Highway trailer with integral fuel cell/chassis, lights, fenders, tie downs, lifting bail, front and rear jacks, and trailer breaks

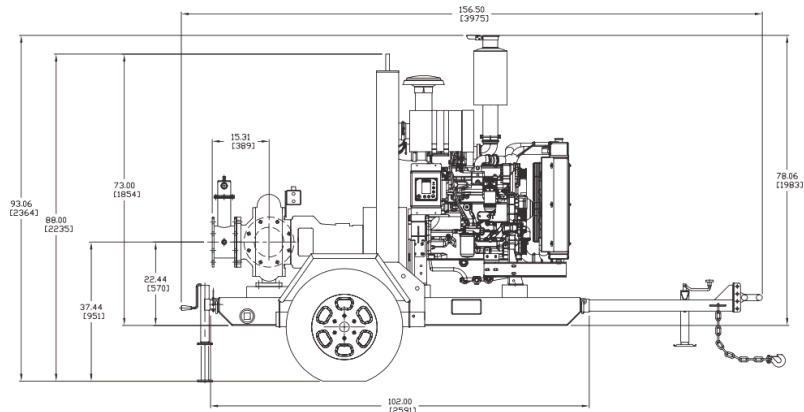

### Contact Us!

434-664-8845

mark@watermngt.com

wendy@watermngt.com

www.watermngt.com