

AcoustiFLO Fans: Retrofit Solutions and Beyond

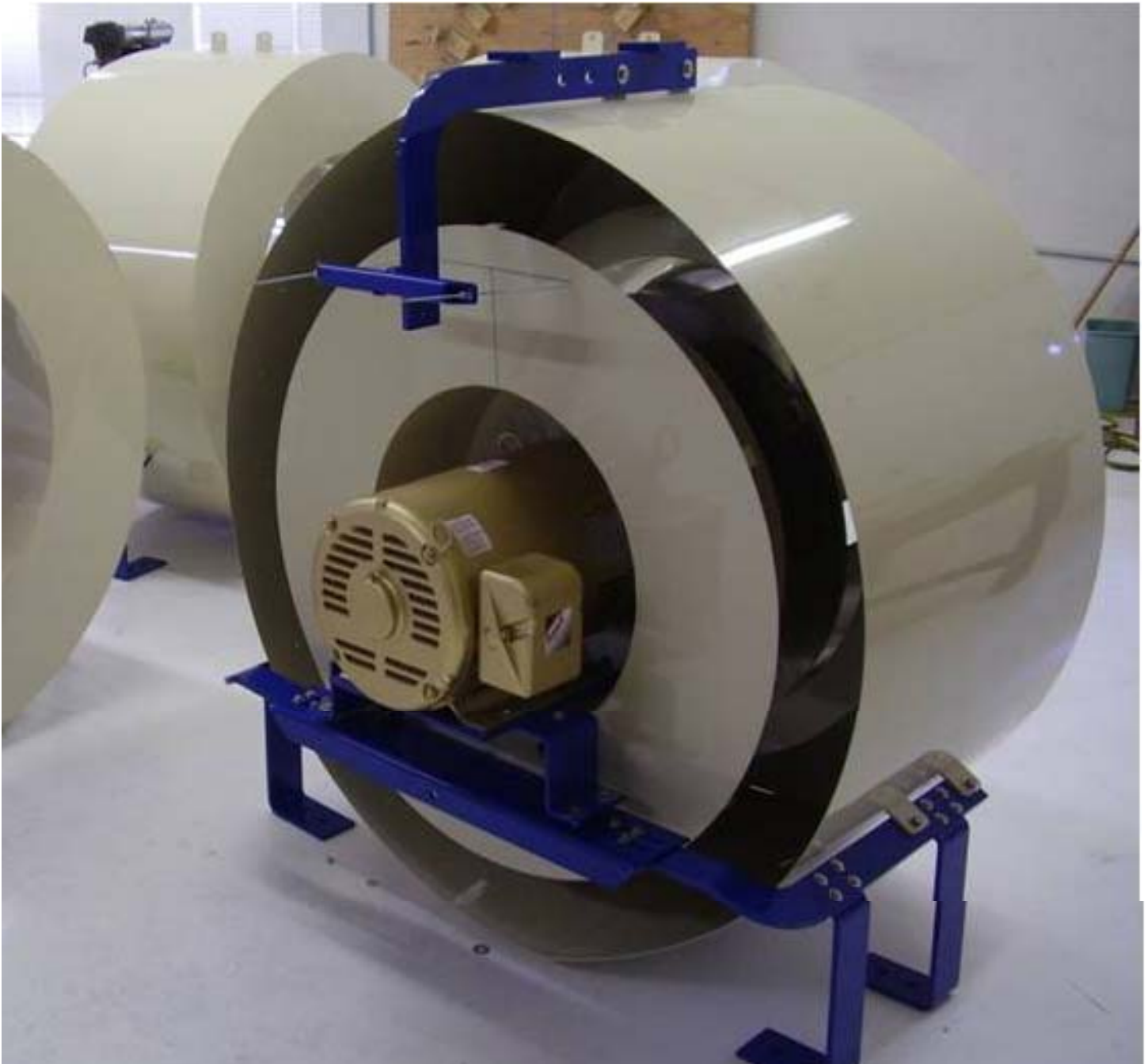

AcoustiFLO

The most energy efficient plenum fan in the world!

The AcoustiFLO Modular Fan

RETROFITS

- Ideal for fan replacement inside any air handling unit
- Module is 35" to 42" deep and 48" in diameter
- Weight is 350 pounds + motor weight
- Configured with an odd or even number of fans
- Odd quantities nest inside each other
- Proven reliability

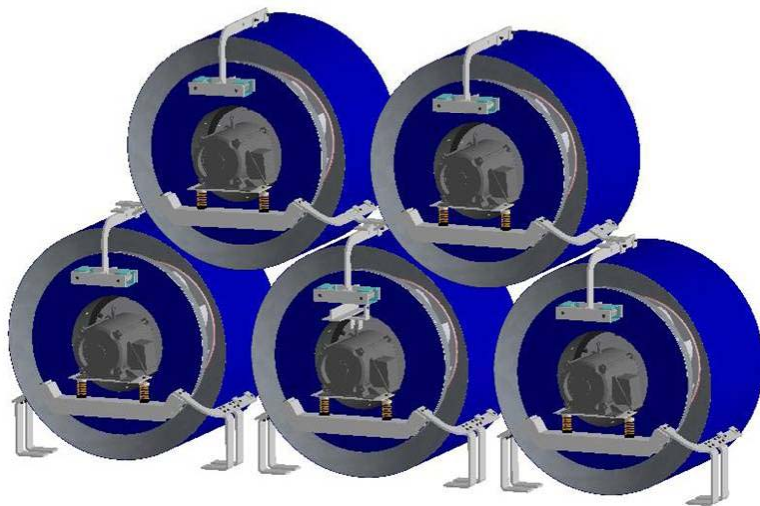

MAINTENANCE

- Simple six step process to remove motors
- No rebalance required after motor replacement
- Routine maintenance is the same as any fan



INSTALLATION

- Each module ships on a pallet
- Lift point from the upper arm
- Spring isolator built within each module for decades of vibration protection



WHY ACOUSTIFLO?

- 15% more efficient than traditional fans
- Enhanced flow path for optimum efficiency
- Proven Twin Cities fan with enhancements
- AMCA certified for sound and performance
- 10-12 dB sound power quieter than conventional plenum fans in the first 4 octave bands
- Airflow monitoring of each fan
- Direct drive- no belts, sheaves or fan bearings
- AcoustiFLO fans can be factory installed inside units for new construction

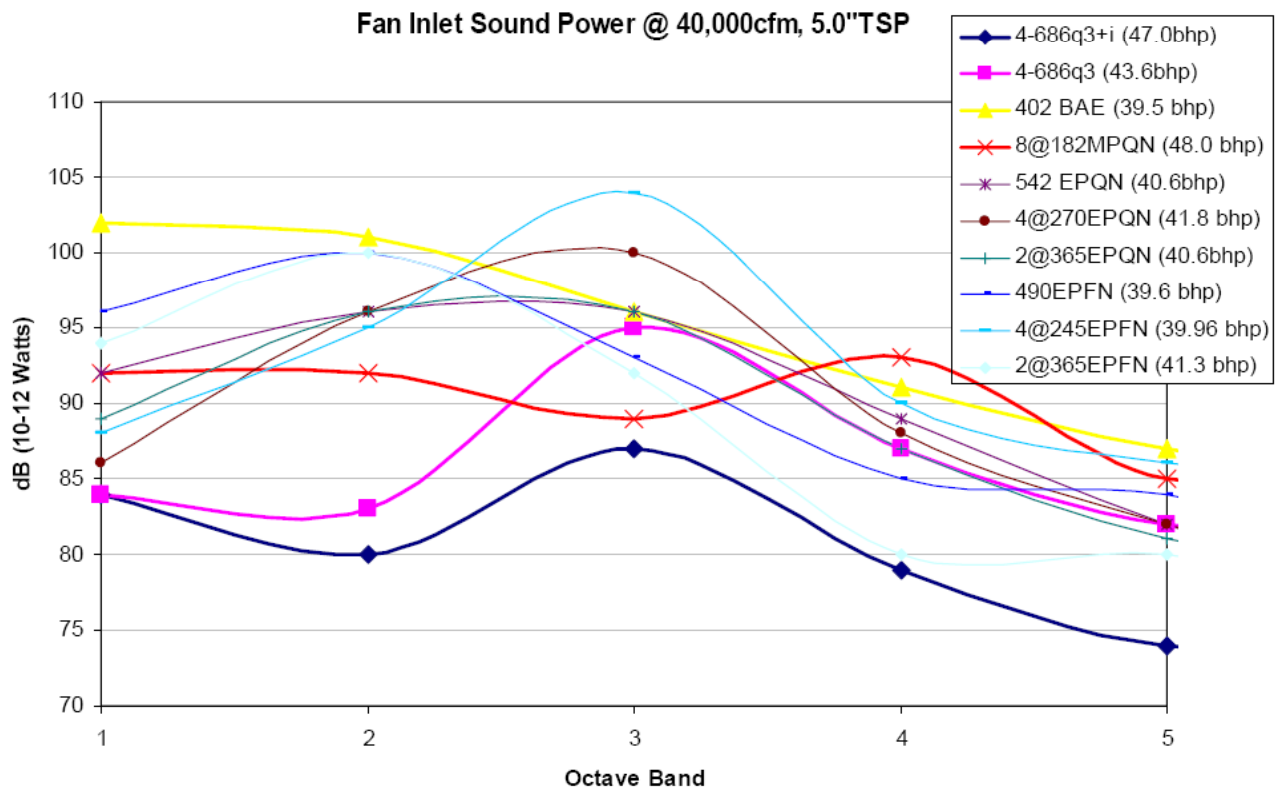
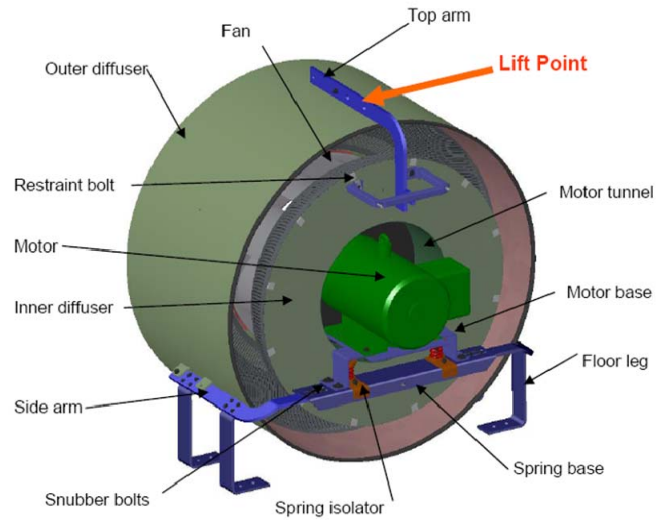

AcoustiFLO

**To learn more about AcoustiFLO, please contact
Critical Systems today!**



**12216 Parklawn Drive, Suite 201
Rockville, MD 20852**

**Phone: 301.545.5100
Fax: 866.400.0750**

**Visit us online!
www.criticalsystemsllc.com**