

# BDU

## Belt Drive - Centrifugal Up-Blast Fans

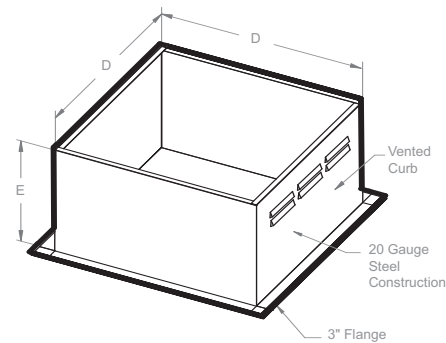
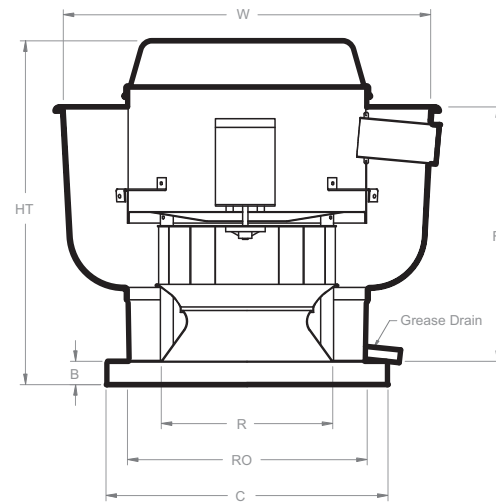

### Features & Benefits

- **Complete range of motors** available to meet specific application needs
- **Heavy duty construction**, durable and weather resistant
- **Non-overloading backward inclined wheels, blades and inlets** fabricated from 3003-H14 aluminum
- **Wall mount applications**; units up to 24" nominal wheel can be wall mounted
- **Forced fresh air** through the motor compartment cools motor and ensures long motor life
- **Quick release latches** allow for easy access to motor compartment
- **Variable pitch motor pulley** allows for field adjustment and system balancing
- **High efficiency** combined with low tip speeds result in quiet operation
- **Fully welded, leak-proof grease drain**
- **Vibration isolation**

### Options

- External disconnect switch
- Gravity Damper (*UL 705 only*)
- Motorized Damper (*UL 705 only*)
- Wall Mount Sleeve
- Bird Screen (*UL 705 only*)
- Grease Collection Box
- Roof Curb (*vented & non vented*)
- Base Hinging Kit or Hinged Sub Base (*for NFPA96 compliance*)

### Certifications



FloAire® certifies that Models BDU11 thru BDU36 shown herein are licensed to bear the AMCA seal. The ratings shown are based on tests & procedures performed in accordance with AMCA Publication 211 and Publication 311, and comply with the requirements of the AMCA Certified Ratings Program.



Models BDU11 thru BDU36 are ETL Listed and comply with UL705 (electrical) and UL762 Standards and CSA Std. C22.2, No. 113.

### Measurements

MODEL	HT	W	B	C	D	E	F	R	RO	Weight Lbs	Damper Sq.
<b>BDU11</b>	25 1/4	27 1/4	2	21	19 1/2	22	18 1/2	12 1/8	16	105	15
<b>BDU13</b>	27 1/4	30 1/4	2	21	19 1/2	20	21 1/2	13 1/4	16	120	15
<b>BDU15</b>	30 1/2	33 3/4	2	24 3/4	23	20	23	14 7/8	20	140	19
<b>BDU18</b>	33 3/4	39 3/8	2	28	26 1/2	20	23 1/2	16 1/2	24	190	23
<b>BDU20</b>	33 3/8	38 7/8	2	28	26 1/2	20	29 1/2	18	24	195	23
<b>BDU24</b>	37 1/2	43 3/8	2	33	31 1/2	20	30 5/8	23 7/8	28	270	27
<b>BDU30</b>	40	52 3/4	2	40	38 1/2	20	33 1/2	24	36	410	35
<b>BDU36</b>	49 1/2	66	2	44 1/2	43	20	47 1/2	30 3/4	36	470	35 1/2

### Motor Availability

HP	Single Phase		Three Phase	
	Open	2 Speed	Open	2 Speed
<b>1/4</b>	•	na	na	na
<b>1/3</b>	•	na	na	na
<b>1/2</b>	•	•	•	•
<b>3/4</b>	•	•	•	•
<b>1</b>	•	•	•	•
<b>1 1/2</b>	•	•	•	•
<b>2</b>	•	na	•	•
<b>3</b>	•	na	•	•
<b>5</b>	na	na	•	•
<b>7 1/2</b>	•	na	•	•

### Motor Frame

Model	Largest Frame
<b>BDU11</b>	56
<b>BDU13</b>	56
<b>BDU15</b>	145T
<b>BDU18</b>	145T
<b>BDU20</b>	145T
<b>BDU24</b>	182T
<b>BDU30</b>	182T
<b>BDU36</b>	213T

# BDU

## Belt Drive - Centrifugal Up-Blast Fans



**BHP** (Brake Horsepower): The actual power developed by a motor as measured by the force applied to a shaft or flywheel.

### Performance

MODEL	CFM	0.00" sp	0.25" sp	0.50" sp	0.75" sp	1.00" sp	1.25" sp	1.50" sp	1.75" sp	2.00" sp
		RPM Sone/BHP	RPM Sone/BHP	RPM Sone/BHP	RPM Sone/BHP	RPM Sone/BHP	RPM Sone/BHP	RPM Sone/BHP	RPM Sone/BHP	RPM Sone/BHP
BDU11	800	900 3.4 / 0.05	1062 4.5 / 0.09	1242 4.9 / 0.14	1391 6.4 / 0.19	1527 10.4 / 0.25				
BDU11	1000	1038 4.7 / 0.07	1235 6.1 / 0.13	1397 7.6 / 0.20	1536 11.7 / 0.26	1658 12.3 / 0.33	1773 13 / 0.40	1883 13.5 / 0.48		
BDU11	1200	1246 6.1 / 0.13	1413 8.9 / 0.20	1560 12.9 / 0.27	1693 14.1 / 0.35	1807 14.8 / 0.43				
BDU11	1400	1454 11.6 / 0.20	1600 14 / 0.28	1733 15.3 / 0.37	1854 16.4 / 0.45					
BDU11	1600	1661 15 / 0.30	1790 16.4 / 0.39	1912 16 / 0.49						
BDU11	1800	1869 17.8 / 0.43								
BDU13	1200	800 5.7 / 0.07	909 6.8 / 0.12	1045 8.9 / 0.18	1180 11.4 / 0.26	1311 12.6 / 0.34	1442 15.2 / 0.43			
BDU13	1400	896 8.3 / 0.09	1017 10.1 / 0.16	1135 12.6 / 0.23	1252 12.1 / 0.31	1367 14.4 / 0.40	1480 15.7 / 0.50			
BDU13	1600	1024 11.1 / 0.14	1131 13.1 / 0.21	1235 13.9 / 0.29	1338 14.9 / 0.38	1439 15.8 / 0.48				
BDU13	1800	1152 14.4 / 0.20	1247 14.6 / 0.28	1340 15.4 / 0.37	1432 16.6 / 0.46					
BDU13	2000	1280 14.8 / 0.28	1366 17.1 / 0.36	1450 17.9 / 0.46						
BDU13	2200	1408 18.7 / 0.37	1486 19.4 / 0.46							
BDU13	2400	1536 21 / 0.48								
BDU15	1600	700 5.1 / 0.09	779 6.5 / 0.14	911 8.3 / 0.23	1034 9.6 / 0.32	1151 12.6 / 0.43	1263 14.7 / 0.55			
BDU15	1800	719 6.9 / 0.10	844 9.2 / 0.18	964 10.4 / 0.27	1077 10.8 / 0.37	1184 12.5 / 0.49	1288 14.8 / 0.61	1389 15.4 / 0.74	1486 16.5 / 0.89	
BDU15	2000	798 8.7 / 0.13	912 10.7 / 0.22	1021 10.2 / 0.32	1125 13.2 / 0.43	1225 13.6 / 0.55	1322 14.9 / 0.68	1415 15.6 / 0.81	1507 16.7 / 0.96	
BDU15	2200	878 10.2 / 0.18	981 12.2 / 0.27	1083 12.6 / 0.38	1180 14 / 0.50	1272 15.9 / 0.62	1362 15.8 / 0.75	1449 16 / 0.89		
BDU15	2400	958 11.6 / 0.23	1053 12.4 / 0.33	1146 14.3 / 0.45	1236 15.4 / 0.57	1324 17.5 / 0.70	1408 17.3 / 0.84	1490 17.1 / 0.98		
BDU15	2600	1038 12 / 0.29	1125 14.3 / 0.40	1212 15.1 / 0.52	1297 17.5 / 0.65	1379 18.6 / 0.79	1458 19.6 / 0.94			
BDU15	2800	1118 14.1 / 0.36	1199 15.5 / 0.48	1280 18.1 / 0.61	1359 18.7 / 0.75	1436 19.7 / 0.89				
BDU15	3000	1198 15.5 / 0.44	1273 19.1 / 0.57	1349 19.7 / 0.71	1424 20 / 0.85	1496 21 / 1.00				
BDU15	3200	1277 19.4 / 0.54	1348 21 / 0.67	1419 21 / 0.82	1490 22 / 0.97					
BDU15	3400	1357 21 / 0.65	1423 22 / 0.79	1491 23 / 0.94						
BDU15	3600	1437 22 / 0.77	1499 24 / 0.92							
BDU15	3800	1516 24 / 0.90								
BDU18	1500	400 2.2 / 0.04	534 3.6 / 0.11	655 5.6 / 0.19						
BDU18	2000	524 4.2 / 0.09	638 6 / 0.18	733 7.7 / 0.28	822 9 / 0.39					
BDU18	2500	655 7.4 / 0.17	750 9.5 / 0.28	833 10.3 / 0.40	907 11 / 0.52	978 11.6 / 0.66	1050 12.2 / 0.80			
BDU18	3000	786 11.2 / 0.29	866 12.2 / 0.42	940 12.8 / 0.56	1007 13 / 0.70	1069 12.5 / 0.85	1129 13.8 / 1.01	1188 15 / 1.17	1248 16.1 / 1.35	1310 17.3 / 1.55
BDU18	3500	916 13.9 / 0.46	986 14.8 / 0.61	1052 14.6 / 0.77	1113 15.1 / 0.94	1170 16.4 / 1.10	1224 17.6 / 1.27	1276 18 / 1.45	1327 18.5 / 1.64	1377 19 / 1.83
BDU18	4000	1047 15.6 / 0.69	1108 17.1 / 0.86	1168 17.7 / 1.04	1224 19.4 / 1.23	1276 20 / 1.41	1326 20 / 1.60	1374 21 / 1.80	1420 21 / 2.00	
BDU18	4500	1178 19 / 0.98	1232 21 / 1.18	1286 22 / 1.38	1337 22 / 1.58	1386 23 / 1.79	1433 24 / 2.00			
BDU18	5000	1309 24 / 1.35	1358 24 / 1.56	1406 25 / 1.78						
BDU18	5500	1440 27 / 1.80								
BDU20	2200	400 3 / 0.06	518 4.4 / 0.16	632 6.1 / 0.29						
BDU20	2700	490 4.8 / 0.12	584 6.2 / 0.23	684 8 / 0.38	774 9.5 / 0.53	862 11.3 / 0.70				
BDU20	3200	581 6.9 / 0.20	657 8.3 / 0.33	744 10.3 / 0.49	825 10.5 / 0.66	902 12.2 / 0.84	976 14 / 1.03	1050 15.4 / 1.24		
BDU20	3700	672 9.6 / 0.31	735 11 / 0.46	810 11.5 / 0.63	884 12.4 / 0.82	954 13.5 / 1.02	1020 15 / 1.23	1085 16.1 / 1.44	1148 17.6 / 1.67	1212 19.7 / 1.92
BDU20	4200	763 12.5 / 0.45	817 12.5 / 0.61	881 13.5 / 0.80	947 14.7 / 1.01	1012 16 / 1.22	1073 16.6 / 1.45	1132 17.5 / 1.69	1189 19 / 1.93	
BDU20	4700	853 14.4 / 0.63	901 15.8 / 0.81	956 16.2 / 1.01	1015 17.2 / 1.23	1074 17.7 / 1.47	1131 18.7 / 1.71	1187 20 / 1.97		
BDU20	5200	944 17.3 / 0.85	986 19 / 1.05	1034 18.9 / 1.27	1087 19.1 / 1.50	1141 20 / 1.75				
BDU20	5700	1035 21 / 1.12	1073 21 / 1.34	1115 21 / 1.57	1162 22 / 1.82					
BDU20	6200	1126 24 / 1.44	1160 24 / 1.68	1199 25 / 1.93						
BDU20	6700	1217 28 / 1.82								

Performance data continued on next page

# BDU

## Belt Drive - Centrifugal Up-Blast Fans



**BHP** (Brake Horsepower): The actual power developed by a motor as measured by the force applied to a shaft or flywheel.

### Performance

MODEL	CFM	0.00 sp	0.25 sp	0.50 sp	0.75 sp	1.00 sp	1.25 sp	1.50 sp	1.75 sp	2.00 sp
		RPM Sone/BHP	RPM Sone/BHP	RPM Sone/BHP	RPM Sone/BHP	RPM Sone/BHP	RPM Sone/BHP	RPM Sone/BHP	RPM Sone/BHP	RPM Sone/BHP
<b>BDU24</b>	3500	400 6 / 0.15	480 7.4 / 0.30	568 8.9 / 0.49	653 11.6 / 0.72	735 14 / 0.97				
<b>BDU24</b>	4500	492 8.8 / 0.27	569 10.1 / 0.49	641 12 / 0.72	710 13.3 / 0.97	776 14.8 / 1.24	842 15.9 / 1.54	907 17.3 / 1.86	969 19.4 / 2.21	
<b>BDU24</b>	5500	601 11.7 / 0.50	665 13.3 / 0.76	726 14.6 / 1.03	784 15.8 / 1.32	841 15.9 / 1.62	896 17 / 1.93	950 18.7 / 2.27	1004 21 / 2.63	1057 23 / 3.01
<b>BDU24</b>	6500	710 15.4 / 0.82	764 16.9 / 1.12	817 17 / 1.44	868 17.5 / 1.77	918 18.1 / 2.11	966 19.8 / 2.46	1013 21 / 2.82	1059 23 / 3.20	1105 25 / 3.60
<b>BDU24</b>	7500	820 18.1 / 1.26	866 19.3 / 1.61	913 19.5 / 1.97	958 21 / 2.34	1002 22 / 2.72	1045 23 / 3.11	1087 25 / 3.51	1128 27 / 3.91	1169 29 / 4.34
<b>BDU24</b>	8500	929 22 / 1.84	970 24 / 2.22	1011 24 / 2.63	1052 26 / 3.04	1092 27 / 3.47	1130 29 / 3.90	1168 29 / 4.33	1206 32 / 4.78	
<b>BDU24</b>	9500	1038 27 / 2.56	1075 29 / 2.99	1112 29 / 3.44	1149 31 / 3.90	1185 33 / 4.36	1220 34 / 4.83			
<b>BDU24</b>	10500	1147 35 / 3.46	1181 37 / 3.94	1214 39 / 4.43	1248 39 / 4.93					
<b>BDU24</b>	11500	1257 41 / 4.55								
<b>BDU30</b>	5000	321 4.8 / 0.23	381 5.7 / 0.44	441 7 / 0.69	497 8.8 / 0.96					
<b>BDU30</b>	6000	385 7 / 0.39	433 7.8 / 0.65	487 9.1 / 0.93	535 10.2 / 1.23	582 11.4 / 1.55	629 13 / 1.90			
<b>BDU30</b>	7000	449 9.7 / 0.62	489 10.4 / 0.91	536 11.2 / 1.23	580 11.6 / 1.57	621 12.7 / 1.92	661 13.8 / 2.29	701 15 / 2.69	741 16 / 3.10	
<b>BDU30</b>	8000	513 12.8 / 0.93	546 12.9 / 1.25	587 12.8 / 1.61	628 13.4 / 1.99	666 14.7 / 2.38	702 15 / 2.78	737 15.9 / 3.19	772 16.8 / 3.63	807 17.8 / 4.08
<b>BDU30</b>	9000	577 14 / 1.32	606 15.1 / 1.68	641 14.6 / 2.07	677 15.7 / 2.49	713 16.3 / 2.92	747 17.5 / 3.36	779 17 / 3.80	811 17.9 / 4.27	842 19.2 / 4.74
<b>BDU30</b>	10000	641 16.4 / 1.81	666 17.3 / 2.21	697 17.8 / 2.63	729 17.3 / 3.09	762 18.3 / 3.56	794 19.2 / 4.03	825 20 / 4.52		
<b>BDU30</b>	11000	705 18.8 / 2.41	728 19.6 / 2.84	754 21 / 3.30	783 19 / 3.79	814 19.9 / 4.30	843 22 / 4.82			
<b>BDU30</b>	12000	769 21 / 3.13	790 22 / 3.60	813 23 / 4.09	839 24 / 4.62					
<b>BDU30</b>	13000	833 27 / 3.98	852 27 / 4.48							
<b>BDU30</b>	14000	897 30 / 4.97								
<b>BDU36</b>	10000	338 8.1 / 0.58	381 9.3 / 1.02	426 10.5 / 1.52	470 11.7 / 2.05	514 13.6 / 2.62	558 15.4 / 3.23	602 17.1 / 3.88	645 18.8 / 4.58	687 20 / 5.31
<b>BDU36</b>	12000	406 11.8 / 1.00	441 12.7 / 1.51	478 13.1 / 2.09	515 14.1 / 2.70	552 15.2 / 3.34	589 16.6 / 4.01	626 18.1 / 4.71	663 19.4 / 5.44	699 21 / 6.20
<b>BDU36</b>	14000	474 15 / 1.59	504 15.9 / 2.17	535 17.2 / 2.82	567 17.5 / 3.51	598 18.5 / 4.23	630 18.2 / 4.97	662 19.3 / 5.73	694 20 / 6.52	725 23 / 7.33
<b>BDU36</b>	16000	541 18.7 / 2.37	567 20 / 3.02	594 20 / 3.74	622 21 / 4.51	650 22 / 5.30	677 23 / 6.12	705 24 / 6.96		
<b>BDU36</b>	18000	609 23 / 3.37	632 24 / 4.10	656 23 / 4.89	680 25 / 5.73	705 26 / 6.60	729 27 / 7.49			
<b>BDU36</b>	20000	676	697	719	740					

Performance shown is for installation Type A; Free Inlet, Free Outlet. Power Rating (BHP) does not include Drive Losses. Performance Ratings do not include the effects of appurtenances in the air stream. The Sound Ratings shown are loudness values in fan sones at 5 ft. (1.5m) in a hemispherical free field calculated per AMCA Standards 301. Values shown are for installation Type A; Free inlet fan sone levels. The AMCA Certified Ratings Sound Seal applies to Sone Ratings only.

# BDU

Belt Drive - Centrifugal Up-Blast Fans

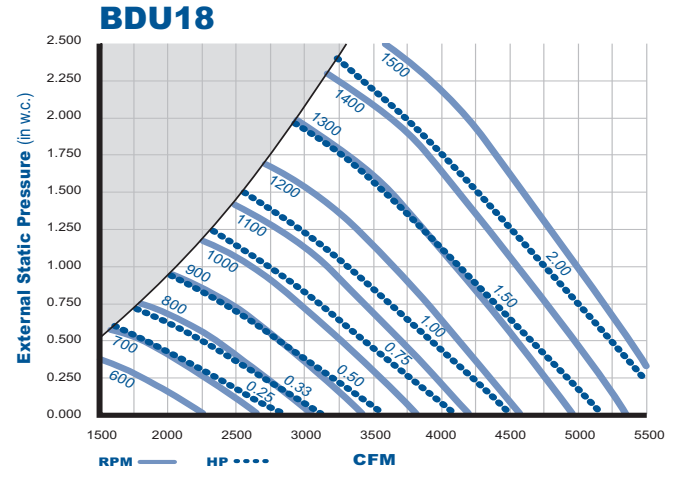
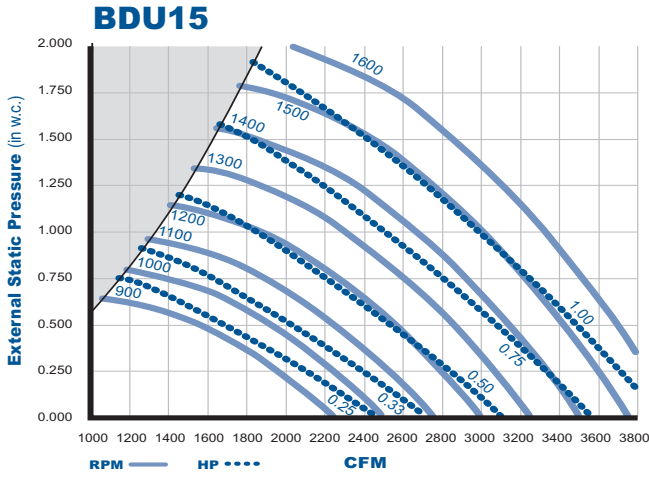
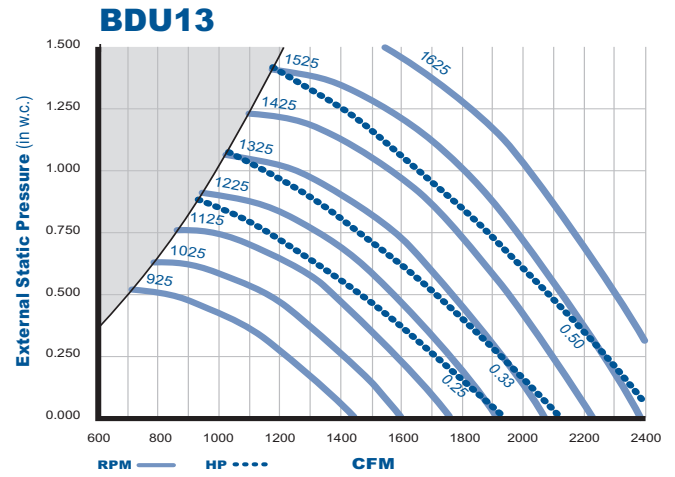
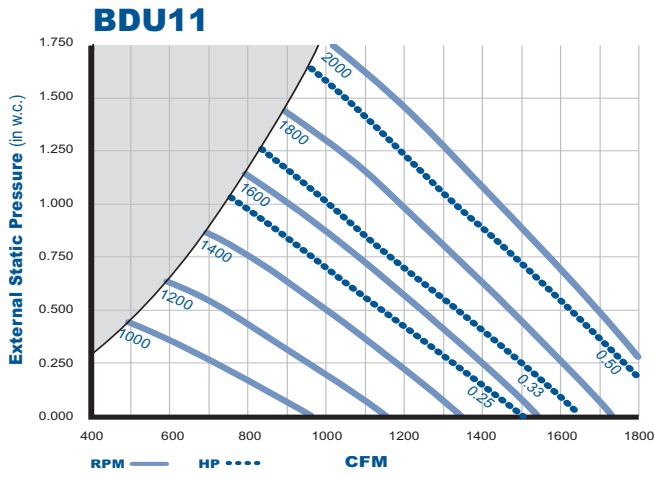

# BDU

Belt Drive - Centrifugal Up-Blast Fans

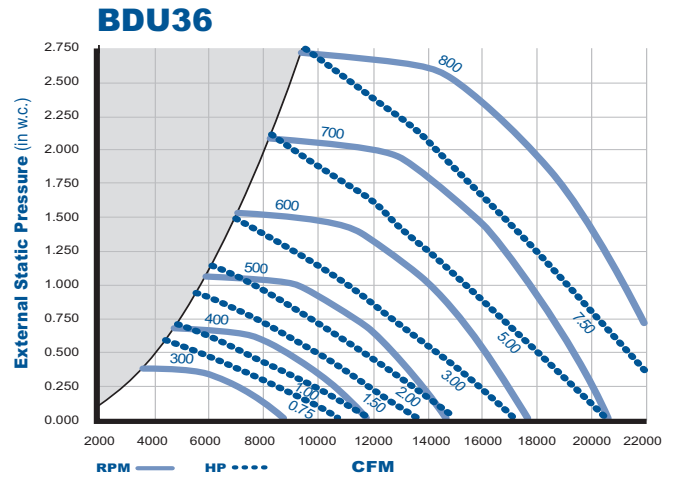
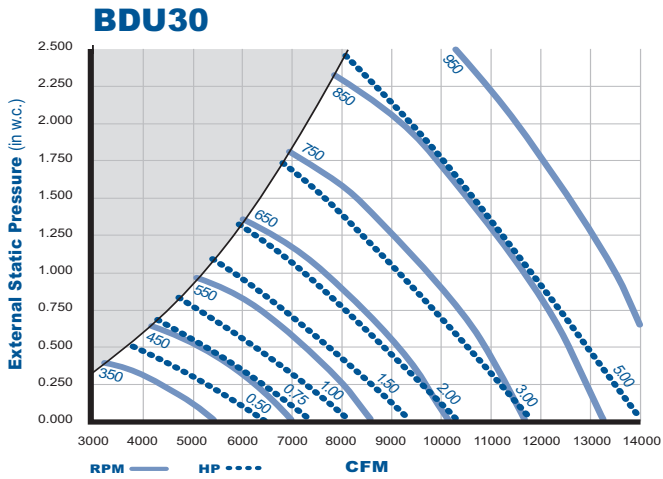
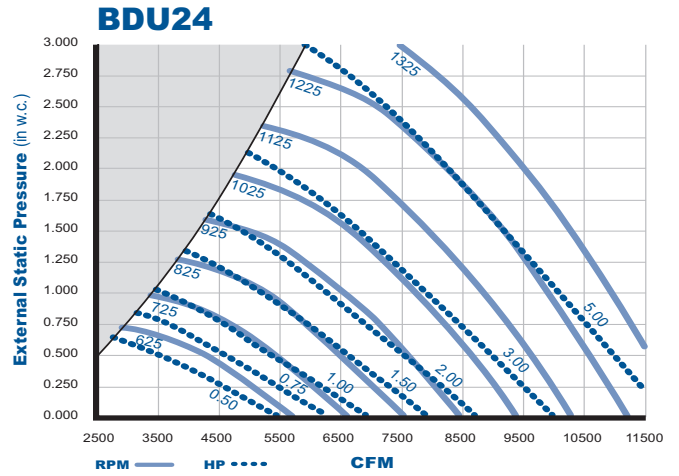
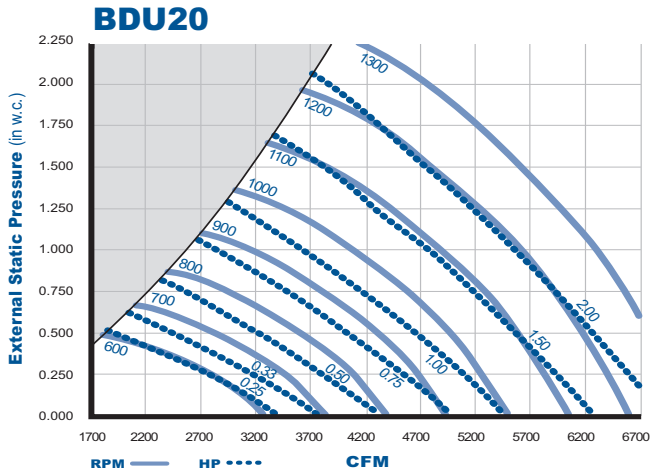

# BDU-HP

## Belt Drive - High Pressure

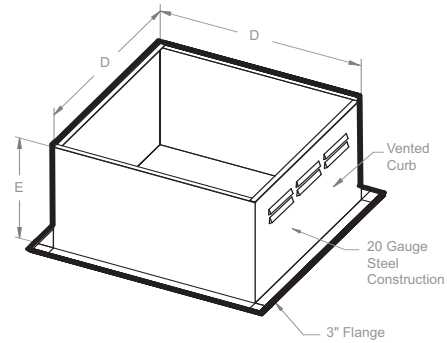
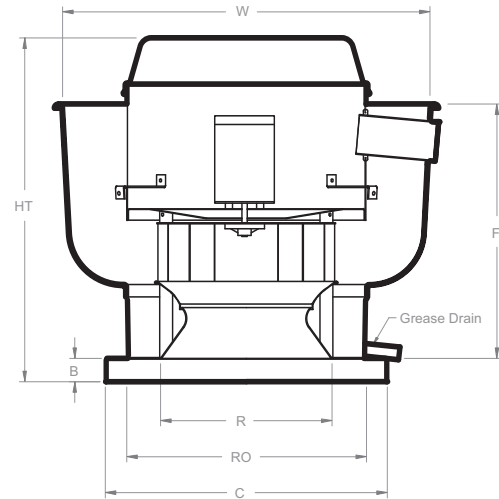

### Features & Benefits

- **Complete range of motors** available to meet specific application needs
- **Heavy duty construction**, durable and weather resistant
- **Non-overloading backward inclined wheels, blades and inlets** fabricated from 3003-H14 aluminum
- **Wall mount applications**; units up to 24" nominal wheel can be wall mounted
- **Forced fresh air** through the motor compartment cools motor and ensures long motor life
- **Quick release latches** allow for easy access to motor compartment
- **Variable pitch motor pulley** allows for field adjustment and system balancing
- **High efficiency** combined with low tip speeds result in quiet operation
- **Fully welded, leak-proof grease drain**
- **Vibration isolation**

### Options

- External disconnect switch
- Gravity Damper (*UL 705 only*)
- Motorized Damper (*UL 705 only*)
- Wall Mount Sleeve
- Bird Screen (*UL 705 only*)
- Grease Collection Box
- Roof Curb (*vented & non vented*)
- Base Hinging Kit or Hinged Sub Base (*for NFPA96 compliance*)

### Certifications



FloAire® certifies that Models BDU15HP thru BDU30HP shown herein are licensed to bear the AMCA seal. The ratings shown are based on tests & procedures performed in accordance with AMCA Publication 211 and Publication 311, and comply with the requirements of the AMCA Certified Ratings Program.



Models BDU15HP thru BDU30HP are ETL Listed and comply with UL705 (electrical) and UL762 Standards and CSA Std. C22.2, No. 113.

### Measurements

MODEL	HT	W	B	C	D	E	F	R	RO	Weight Lbs	Damper Sq.
<b>BDU15HP</b>	30 1/2	33 3/4	2	24 3/4	23	20	23	14 7/8	20	140	19
<b>BDU18HP</b>	33 3/4	39 3/8	2	28	26 1/2	20	23 1/2	16 1/2	24	190	23
<b>BDU20HP</b>	33 3/8	38 7/8	2	28	26 1/2	20	29 1/2	18	24	195	23
<b>BDU24HP</b>	37 1/2	43 3/8	2	33	31 1/2	20	30 5/8	23 7/8	28	270	27
<b>BDU30HP</b>	40	52 3/4	2	40	38 1/2	20	33 1/2	24	36	410	35

### Motor Availability

HP	Single Phase		Three Phase	
	Open	2 Speed	Open	2 Speed
1/3	•	na	na	na
1/2	•	•	•	•
3/4	•	•	•	•
1	•	•	•	•
1 1/2	•	•	•	•
2	•	na	•	•
3	•	na	•	•
5	•	na	•	•

### Motor Frame

Model	Largest Frame
<b>BDU15HP</b>	145T
<b>BDU18HP</b>	145T
<b>BDU20HP</b>	145T
<b>BDU24HP</b>	182T
<b>BDU30HP</b>	182T

# BDU-HP

## Belt Drive - High Pressure



**BHP** (Brake Horsepower): The actual power developed by a motor as measured by the force applied to a shaft or flywheel.

### Performance

		0.00 sp	0.50 sp	1.00 sp	1.50 sp	2.00 sp	2.50 sp	3.00 sp	3.50 sp	4.00 sp
MODEL	CFM	RPM Sone/BHP	RPM Sone/BHP	RPM Sone/BHP	RPM Sone/BHP	RPM Sone/BHP	RPM Sone/BHP	RPM Sone/BHP	RPM Sone/BHP	RPM Sone/BHP
BDU15HP	1200	800 5.4 / 0.07	1034 7.7 / 0.19	1262 11.5 / 0.34	1467 12.5 / 0.52	1655 14.9 / 0.72	1829 17.3 / 0.94			
BDU15HP	1400	902 6.5 / 0.09	1132 9.8 / 0.24	1335 13.5 / 0.41	1523 12.7 / 0.60	1697 15.4 / 0.81				
BDU15HP	1600	1030 8.6 / 0.14	1236 12.2 / 0.30	1418 13 / 0.48	1590 13.5 / 0.69	1752 15.1 / 0.91				
BDU15HP	1800	1159 11.1 / 0.20	1345 14.9 / 0.37	1511 14.4 / 0.57	1670 14.4 / 0.79					
BDU15HP	2000	1288 14.2 / 0.27	1458 15.3 / 0.46	1610 15.5 / 0.68	1756 16.1 / 0.91					
BDU15HP	2200	1417 14.7 / 0.36	1574 16.2 / 0.57	1715 16.7 / 0.80						
BDU15HP	2400	1545 17.5 / 0.47	1688 18 / 0.69	1822 18.7 / 0.94						
BDU15HP	2600	1674 19.6 / 0.60	1809 20 / 0.84							
BDU15HP	2800	1802 22 / 0.75								
BDU15HP	3000	1932 24 / 0.92								
BDU18HP	2500	894 9.8 / 0.24	1043 11.6 / 0.47	1189 13 / 0.74	1326 12.3 / 1.03	1454 14.3 / 1.35	1575 15.6 / 1.68			
BDU18HP	3000	1073 13.7 / 0.42	1196 15.1 / 0.68	1321 14.8 / 0.99	1441 15.1 / 1.32	1555 16.8 / 1.67				
BDU18HP	3500	1251 18.1 / 0.66	1356 17 / 0.96	1464 17.8 / 1.31	1570 18.8 / 1.67					
BDU18HP	4000	1430 17.9 / 0.98	1521 20 / 1.33	1616 21 / 1.71						
BDU18HP	4500	1609 23 / 1.40	1689 23 / 1.78							
BDU18HP	5000	1788 26 / 1.92								
BDU20HP	3000	800 10.5 / 0.26	917 11.8 / 0.51	1050 13.9 / 0.83	1176 14.2 / 1.17	1296 15.7 / 1.55	1412 18.3 / 1.95	1523 20 / 2.38	1629 22 / 2.83	
BDU20HP	3500	905 13.3 / 0.38	1027 15.4 / 0.69	1145 17.1 / 1.04	1256 16.7 / 1.42	1363 17 / 1.83	1468 19.8 / 2.26	1568 21 / 2.71		
BDU20HP	4000	1034 17.2 / 0.57	1142 19.7 / 0.92	1246 18 / 1.31	1346 18.1 / 1.72	1443 21 / 2.16	1537 22 / 2.62			
BDU20HP	4500	1164 19.8 / 0.81	1259 20 / 1.20	1353 19.8 / 1.63	1444 22 / 2.08	1532 23 / 2.55				
BDU20HP	5000	1293 21 / 1.11	1379 23 / 1.54	1464 24 / 2.01	1548 25 / 2.49	1629 25 / 3.00				
BDU20HP	5500	1422 25 / 1.48	1501 26 / 1.95	1579 27 / 2.45	1655 28 / 2.98					
BDU20HP	6000	1551 28 / 1.92	1623 29 / 2.43	1695 30 / 2.97						
BDU20HP	6500	1680 31 / 2.45	1747 32 / 2.99							
BDU24HP	3000	500 6.7 / 0.14	629 8.5 / 0.41	775 11.8 / 0.77	909 17.1 / 1.20	1031 20 / 1.67	1143 21 / 2.18	1245 22 / 2.73	1341 24 / 3.31	1431 26 / 3.90
BDU24HP	4000	631 10.8 / 0.29	751 13.2 / 0.65	864 15.9 / 1.08	974 21 / 1.55	1080 20 / 2.07	1180 21 / 2.64	1275 22 / 3.24	1365 24 / 3.88	1451 27 / 4.55
BDU24HP	5000	789 16.3 / 0.56	886 17.7 / 1.01	978 21 / 1.50	1069 21 / 2.03	1158 21 / 2.61	1245 22 / 3.23	1329 23 / 3.88	1411 26 / 4.57	
BDU24HP	6000	947 21 / 0.97	1029 22 / 1.49	1107 24 / 2.06	1183 24 / 2.66	1259 25 / 3.30	1333 26 / 3.98	1407 25 / 4.68		
BDU24HP	7000	1104 24 / 1.53	1175 27 / 2.14	1243 27 / 2.78	1310 29 / 3.46	1375 28 / 4.17	1440 29 / 4.91			
BDU24HP	8000	1262 29 / 2.29	1325 31 / 2.98	1385 31 / 3.70	1444 33 / 4.45					
BDU24HP	9000	1420 34 / 3.26	1476 39 / 4.03	1530 38 / 4.83						
BDU24HP	10000	1578 44 / 4.47								
BDU30HP	4000	328 4.6 / 0.14	455 6.9 / 0.52	569 10.1 / 0.98						
BDU30HP	5000	410 7.4 / 0.27	514 9.7 / 0.73	610 11.1 / 1.26	700 13.5 / 1.84	782 15.2 / 2.44				
BDU30HP	6000	491 10.8 / 0.47	581 11.3 / 1.02	662 12.6 / 1.60	741 14.4 / 2.26	817 15.9 / 2.95	887 16.8 / 3.67	953 19.5 / 4.39		
BDU30HP	7000	573 12.9 / 0.74	652 14.8 / 1.38	722 15.5 / 2.04	792 15.4 / 2.75	859 16.4 / 3.52	925 18.4 / 4.32			
BDU30HP	8000	655 16 / 1.11	725 17.2 / 1.84	788 17.3 / 2.57	849 18.5 / 3.35	910 17.7 / 4.18				
BDU30HP	9000	737 19 / 1.58	800 19.6 / 2.40	857 21 / 3.22	912 20 / 4.06	966 21 / 4.95				
BDU30HP	10000	819 22 / 2.17	877 23 / 3.09	929 23 / 3.99	979 23 / 4.91					
BDU30HP	11000	901 24 / 2.88	954 27 / 3.90	1002 27 / 4.89						
BDU30HP	12000	983 29 / 3.74	1032 33 / 4.86							
BDU30HP	13000	1065 36 / 4.76								

Performance shown is for installation Type A; Free Inlet, Free Outlet. Power Rating (BHP) does not include Drive Losses. Performance Ratings do not include the effects of appurtenances in the air stream. The Sound Ratings shown are loudness values in fan sones at 5 ft. (1.5m) in a hemispherical free field calculated per AMCA Standards 301. Values shown are for installation Type A; Free inlet fan sone levels. The AMCA Certified Ratings Sound Seal applies to Sone Ratings only.

# BDU-HP

Belt Drive - High Pressure

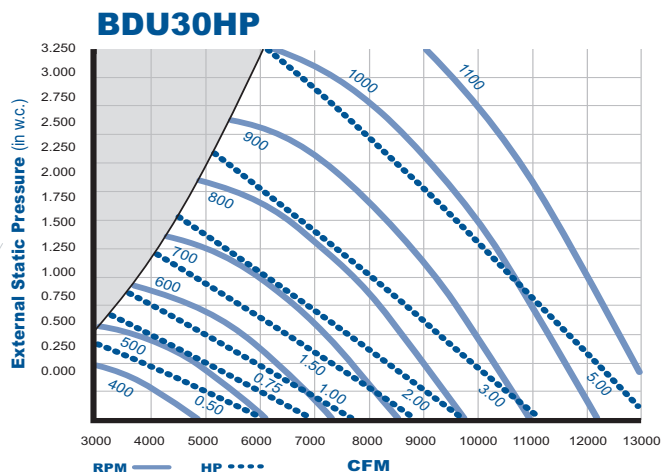
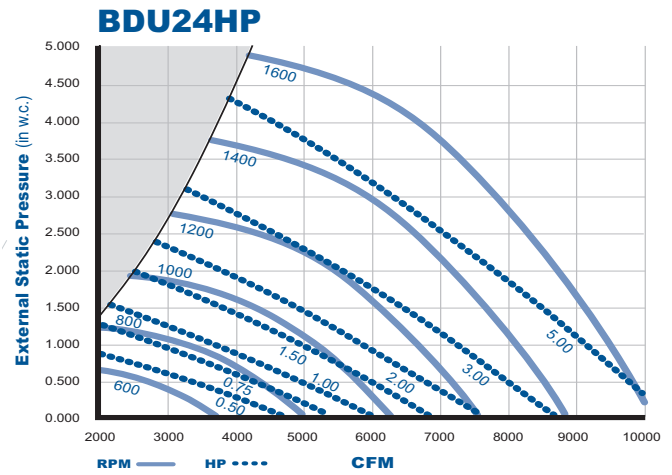
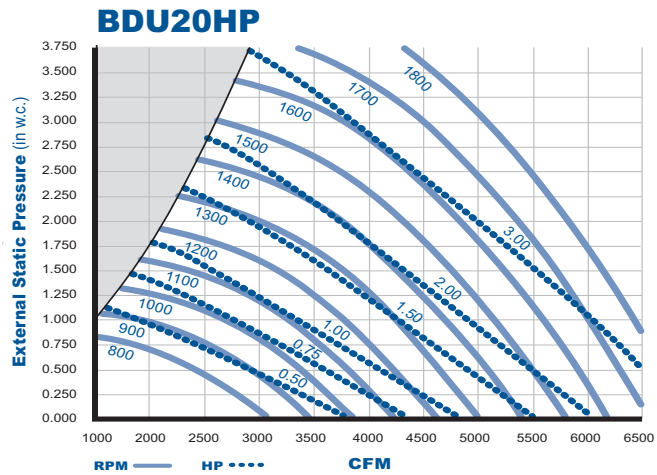
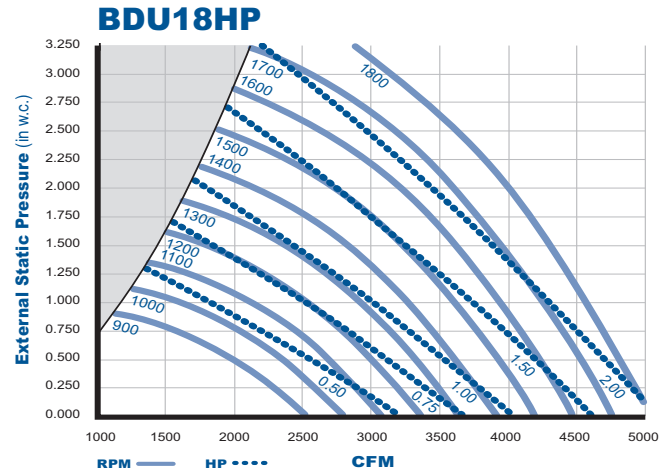
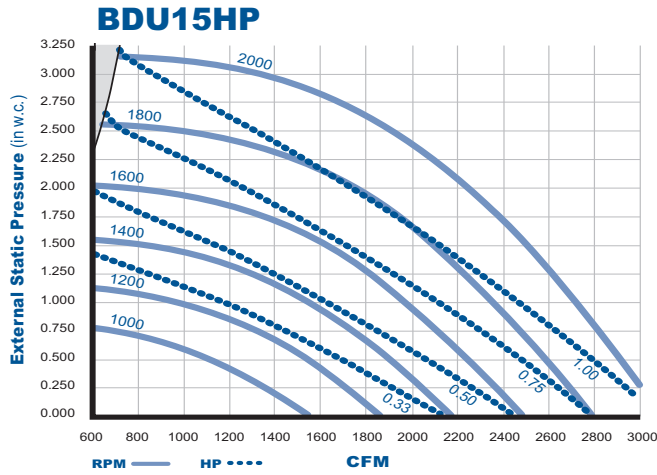



# DU

## Direct Drive - Centrifugal Up-Blast Fans

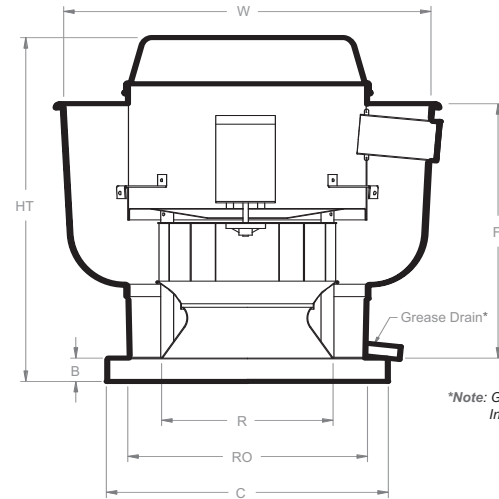

\*Note: Grease Drain Not Installed On DU10HFA

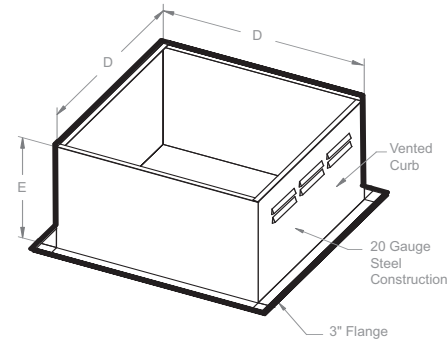

### Features & Benefits

- Completely enclosed drive compartment protects motor from airborne contaminants
- Forced fresh air through the motor compartment cools motor and ensures long motor life
- Variable speed control
- Non-overloading backward inclined wheels, blades and inlets fabricated from 3003-H14 aluminum
- All sizes can be wall mounted
- Quick release latches allow for easy access to motor compartment
- External disconnect switch
- Fully welded leak proof grease drain

### Options

- Gravity Damper (UL705 only)
- Motorized Damper (UL705 only)
- Wall Mount Sleeve
- Roof Curb (Vented and Non-vented)
- Grease Collection Box (size 12 and larger)
- Bird Screen (UL705 only)
- Base Hinging Kit or Hinged Sub Base (for NFPA96 compliance)

### Certifications



FloAire® certifies that Models DU10H thru DU85H shown herein are licensed to bear the AMCA seal. The ratings shown are based on tests & procedures in accordance with AMCA Publication 211 and Publication 311, and comply with the requirements of the AMCA Certified Ratings Program.



Models DU10H thru DU85H are ETL Listed and comply with UL 705 (electrical) Standards. Models DU12H thru DU85H comply with UL 762 Standards. All models comply with CSA Std. C22.2, No. 113.

### Measurements

MODEL	HT	W	B	C	D	E	F	R	RO	Weight Lbs	Damper Sq.
DU10H	14 1/2	17 3/4	2	19	17 1/2	12	9 1/2	8 1/8	13	30	12
DU12H	18	22	2	19	17 1/2	12	14 1/2	10 5/8	13	40	12
DU25H	25 1/4	25 1/2	2	21	19 1/2	12	18 1/2	12 1/8	16	50	15
DU30H	25 1/4	25 1/2	2	21	19 1/2	12	18 1/2	12 1/8	16	50	15
DU33H	25 1/4	25 1/2	2	21	19 1/2	12	18 1/2	12 1/8	16	50	15
DU50H	27 1/4	28 7/8	2	21	19 1/2	12	21 1/2	13 1/4	16	55	15
DU75H	30 1/2	31 7/8	2	24 3/4	23	12	23	14 7/8	20	60	19
DU85H	30 1/2	31 7/8	2	24 3/4	23	12	23	14 7/8	20	60	19

### Motor Availability

\*Variable Frequency Drive

Model	Single Phase Open - 115 Volts		Three Phase 280 - 230/460 Volts	
	1 Speed	Speed Control	1 Speed	VFD*
DU10H	.	.	na	na
DU12H	.	.	na	na
DU25H	.	.	na	na
DU30H	.	.	na	na
DU33H	.	.	.	.
DU50H	.	.	.	.
DU75H	.	.	na	na
DU85H	.	.	.	.

Note: Speed Controls are not shipped with three phase fans.  
Variable Frequency devices are required to adjust three phase motor speed (optional)

# DU

## Direct Drive - Centrifugal Up-Blast Fans



**BHP** (Brake Horsepower): The actual power developed by a motor as measured by the force applied to a shaft or flywheel. Performance shown is for installation Type A; Free Inlet, Free Outlet. Performance includes effect of bird screen in the air stream. Speed (RPM) shown is nominal and performance is based on actual speed of test.

### Performance

MODEL	RPM	Tip Speed	Motor HP	0.00 sp	0.125 sp	0.25 sp	0.375 sp	0.50 sp	0.625 sp	0.75 sp	1.00 sp	1.25 sp
				CFM Sone/BHP	CFM Sone/BHP	CFM Sone/BHP	CFM Sone/BHP	CFM Sone/BHP	CFM Sone/BHP	CFM Sone/BHP	CFM Sone/BHP	CFM Sone/BHP
DU10H	1000	2356	0.07	335 2.5 / 0.02	263 2.5 / 0.02	170 2.5 / 0.02						
DU10H	1100	2592	0.07	369 3.1 / 0.02	304 3.1 / 0.02	226 3.1 / 0.02	112 3.1 / 0.02					
DU10H	1200	2827	0.07	402 4 / 0.03	343 4 / 0.03	277 4 / 0.03	192 4 / 0.03	45 4 / 0.03				
DU10H	1300	3063	0.07	436 4.9 / 0.04	382 4.9 / 0.04	322 4.9 / 0.04	252 4.9 / 0.04	160 4.9 / 0.04				
DU10H	1400	3299	0.07	469 5.9 / 0.05	419 5.9 / 0.05	365 5.9 / 0.05	304 5.9 / 0.05	232 5.9 / 0.05	124 5.9 / 0.05			
DU10H	1500	3534	0.07	503 7.1 / 0.06	457 7.1 / 0.06	407 7.1 / 0.06	353 7.1 / 0.06	290 7.1 / 0.06	215 7.1 / 0.06	99 7.1 / 0.06		
DU10H	1600	3770	0.07	537 7.8 / 0.07	493 7.8 / 0.07	447 7.8 / 0.07	398 7.8 / 0.07	343 7.8 / 0.07	280 7.8 / 0.07	204 7.8 / 0.07		
DU12H	900	2474	0.14	459 3 / 0.03	350 3 / 0.03	201 3 / 0.03						
DU12H	1000	2749	0.14	510 3.7 / 0.04	415 3.7 / 0.04	288 3.7 / 0.04	150 3.7 / 0.04					
DU12H	1100	3024	0.14	561 4.6 / 0.06	476 4.6 / 0.06	371 4.6 / 0.06	244 4.6 / 0.06	114 4.6 / 0.06				
DU12H	1200	3299	0.14	612 5.6 / 0.07	536 5.6 / 0.07	445 5.6 / 0.07	331 5.6 / 0.07	217 5.6 / 0.07	84 5.6 / 0.05			
DU12H	1300	3574	0.14	663 6.6 / 0.09	593 6.6 / 0.09	514 6.6 / 0.09	417 6.6 / 0.09	308 6.6 / 0.09	203 6.6 / 0.09	67 6.6 / 0.04		
DU12H	1400	3848	0.14	714 7.8 / 0.11	650 7.8 / 0.11	579 7.8 / 0.11	495 7.8 / 0.11	395 7.8 / 0.11	297 7.8 / 0.11	198 7.8 / 0.11		
DU12H	1500	4123	0.14	766 9.2 / 0.14	705 9.2 / 0.14	640 9.2 / 0.14	567 9.2 / 0.14	481 9.2 / 0.14	385 9.2 / 0.14	294 9.2 / 0.14	75 9.2 / 0.06	
DU25H	750	2307	0.25	588 1.5 / 0.07	470 1 / 0.07	262 0.7 / 0.07						
DU25H	850	2615	0.25	666 2.1 / 0.10	566 1.7 / 0.10	430 1.3 / 0.10						
DU25H	950	2922	0.25	745 2.8 / 0.14	657 2.5 / 0.14	543 2.2 / 0.14	396 1.8 / 0.14					
DU25H	1050	3230	0.25	823 3.6 / 0.19	746 3.3 / 0.19	654 3.1 / 0.19	539 2.8 / 0.19	328 2.6 / 0.19				
DU30H	1000	3076	0.25	788 4.2 / 0.06	692 4.2 / 0.06	583 4.2 / 0.06						
DU30H	1100	3384	0.25	866 5 / 0.08	780 5 / 0.08	687 5 / 0.08	571 5 / 0.08					
DU30H	1200	3691	0.25	945 5.9 / 0.11	867 5.9 / 0.11	784 5.9 / 0.11	687 5.9 / 0.11	570 5.9 / 0.11				
DU30H	1300	3999	0.25	1024 7 / 0.13	951 7 / 0.13	876 7 / 0.13	793 7 / 0.13	697 7 / 0.13	583 7 / 0.13			
DU30H	1400	4307	0.25	1103 8.1 / 0.17	1035 8.1 / 0.17	966 8.1 / 0.17	894 8.1 / 0.17	809 8.1 / 0.17	712 8.1 / 0.17	606 8.1 / 0.17		
DU30H	1500	4614	0.25	1182 9.4 / 0.21	1119 9.4 / 0.21	1055 9.4 / 0.21	988 9.4 / 0.21	915 9.4 / 0.21	833 9.4 / 0.21	737 9.4 / 0.21		
DU30H	1600	4922	0.25	1261 10.7 / 0.25	1201 10.7 / 0.25	1143 10.7 / 0.25	1080 10.7 / 0.25	1016 10.7 / 0.25	942 10.7 / 0.25	864 10.7 / 0.25	677 10.7 / 0.25	
DU33H	1125	3461	0.33	875 4.4 / 0.09	795 4.1 / 0.09	698 3.8 / 0.09	591 3.6 / 0.09	450 3.4 / 0.09				
DU33H	1225	3768	0.33	953 5.3 / 0.12	879 5.1 / 0.12	794 4.8 / 0.12	701 4.6 / 0.12	594 4.3 / 0.12	435 4.1 / 0.12			
DU33H	1325	4076	0.33	1030 6.3 / 0.15	963 6.1 / 0.15	888 5.8 / 0.15	803 5.6 / 0.15	713 5.4 / 0.15	603 5.2 / 0.15	428 5 / 0.15		
DU33H	1425	4384	0.33	1108 7.4 / 0.19	1045 7.2 / 0.19	979 6.9 / 0.19	901 6.7 / 0.19	821 6.5 / 0.19	730 6.3 / 0.19	622 6.1 / 0.19		
DU33H	1525	4691	0.33	1186 8.6 / 0.23	1127 8.4 / 0.23	1067 8.2 / 0.23	996 7.9 / 0.23	922 7.7 / 0.23	847 7.5 / 0.23	757 7.3 / 0.23	474 6.9 / 0.23	
DU33H	1625	4999	0.33	1264 9.9 / 0.28	1209 9.7 / 0.28	1153 9.5 / 0.28	1090 9.3 / 0.28	1020 9 / 0.28	950 8.8 / 0.28	876 8.7 / 0.28	688 8.3 / 0.28	
DU33H	1725	5306	0.33	1342 11.2 / 0.33	1290 11 / 0.33	1237 10.8 / 0.33	1181 10.6 / 0.33	1116 10.4 / 0.33	1051 10.2 / 0.33	984 10.1 / 0.33	831 9.7 / 0.33	595 9.4 / 0.33
DU50H	1070	3852	0.50	1397 5.8 / 0.13	1296 5.8 / 0.13	1193 5.8 / 0.13	1074 5.8 / 0.13	926 5.8 / 0.13	736 5.8 / 0.13			
DU50H	1170	4212	0.50	1528 6.9 / 0.17	1436 6.9 / 0.17	1343 6.9 / 0.17	1246 6.9 / 0.17	1122 6.9 / 0.17	979 6.9 / 0.17	801 6.9 / 0.17		
DU50H	1270	4572	0.50	1658 8.1 / 0.22	1573 8.1 / 0.22	1489 8.1 / 0.22	1400 8.1 / 0.22	1301 8.1 / 0.22	1185 8.1 / 0.22	1047 8.1 / 0.22		
DU50H	1370	4932	0.50	1789 9.4 / 0.28	1710 9.4 / 0.28	1632 9.4 / 0.28	1551 9.4 / 0.28	1469 9.4 / 0.28	1366 9.4 / 0.28	1259 9.4 / 0.28	975 9.4 / 0.28	
DU50H	1470	5292	0.50	1919 10.7 / 0.34	1846 10.7 / 0.34	1773 10.7 / 0.34	1699 10.7 / 0.34	1622 10.7 / 0.34	1542 10.7 / 0.34	1442 10.7 / 0.34	1217 10.7 / 0.34	910 10.7 / 0.34
DU50H	1570	5652	0.50	2050 12.2 / 0.42	1981 12.2 / 0.42	1913 12.2 / 0.42	1844 12.2 / 0.42	1773 12.2 / 0.42	1701 12.2 / 0.42	1619 12.2 / 0.42	1430 12.2 / 0.42	1191 12.2 / 0.42
DU50H	1670	6012	0.50	2181 13.8 / 0.50	2116 13.8 / 0.50	2052 13.8 / 0.50	1987 13.8 / 0.50	1922 13.8 / 0.50	1854 13.8 / 0.50	1786 13.8 / 0.50	1615 13.8 / 0.50	1418 13.8 / 0.50

# DU

## Direct Drive - Centrifugal Up-Blast Fans



**BHP** (Brake Horsepower): The actual power developed by a motor as measured by the force applied to a shaft or flywheel. Performance shown is for installation Type A; Free Inlet, Free Outlet. Performance includes effect of bird screen in the air stream. Speed (RPM) shown is nominal and performance is based on actual speed of test.

### Performance

MODEL	RPM	Tip Speed	Motor HP	0.00 sp	0.125 sp	0.25 sp	0.375 sp	0.50 sp	0.625 sp	0.75 sp	1.00 sp	1.25 sp
				CFM Sone/BHP	CFM Sone/BHP	CFM Sone/BHP	CFM Sone/BHP	CFM Sone/BHP	CFM Sone/BHP	CFM Sone/BHP	CFM Sone/BHP	CFM Sone/BHP
DDU75H	775	3196	0.75	1712 4.4 / 0.21	1525 4.4 / 0.21	1314 4.4 / 0.21	1066 4.4 / 0.21					
DU75H	875	3608	0.75	1933 5.5 / 0.31	1770 5.5 / 0.31	1591 5.5 / 0.31	1392 5.5 / 0.31	1162 5.5 / 0.31	433 5.5 / 0.31			
DU75H	975	4020	0.75	2154 6.7 / 0.42	2007 6.7 / 0.42	1851 6.7 / 0.42	1683 6.7 / 0.42	1498 6.7 / 0.42	1288 6.7 / 0.42	709 6.7 / 0.42		
DU75H	1075	4433	0.75	2375 8 / 0.57	2242 8 / 0.57	2104 8 / 0.57	1957 8 / 0.57	1797 8 / 0.57	1625 8 / 0.57	1435 8 / 0.57		
DU75H	1175	4845	0.75	2596 9.4 / 0.74	2474 9.4 / 0.74	2352 9.4 / 0.74	2218 9.4 / 0.74	2083 9.4 / 0.74	1931 9.4 / 0.74	1772 9.4 / 0.74	1348 9.4 / 0.74	
DU85H	1025	4226	0.75	2135 10 / 0.17	2008 10 / 0.17	1871 10 / 0.17	1722 10 / 0.17	1546 10 / 0.17	1339 10 / 0.17	1047 10 / 0.17		
DU85H	1125	4639	0.75	2344 11.7 / 0.23	2228 11.7 / 0.23	2109 11.7 / 0.23	1974 11.7 / 0.23	1831 11.7 / 0.23	1667 11.7 / 0.23	1474 11.7 / 0.23		
DU85H	1225	5051	0.75	2552 13.6 / 0.29	2446 13.6 / 0.29	2338 13.6 / 0.29	2218 13.6 / 0.29	2094 13.6 / 0.29	1955 13.6 / 0.29	1804 13.6 / 0.29	1409 13.6 / 0.29	
DU85H	1325	5463	0.75	2760 15.5 / 0.37	2662 15.5 / 0.37	2563 15.5 / 0.37	2458 15.5 / 0.37	2343 15.5 / 0.37	2228 15.5 / 0.37	2094 15.5 / 0.37	1790 15.5 / 0.37	1369 15.5 / 0.37
DU85H	1425	5876	0.75	2969 17.7 / 0.46	2878 17.7 / 0.46	2785 17.7 / 0.46	2693 17.7 / 0.46	2587 17.7 / 0.46	2480 17.7 / 0.46	2373 17.7 / 0.46	2114 17.7 / 0.46	1809 17.7 / 0.46
DU85H	1525	6288	0.75	3177 20 / 0.57	3092 20 / 0.57	3006 20 / 0.57	2920 20 / 0.57	2827 20 / 0.57	2727 20 / 0.57	2627 20 / 0.57	2404 20 / 0.57	2147 20 / 0.57
DU85H	1625	6700	0.75	3385	3306	3225	3144	3063	2969	2875	2685	2457

### DU10H

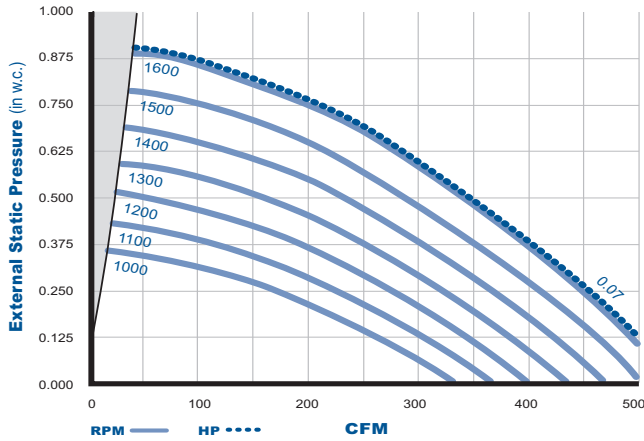

### DU12H

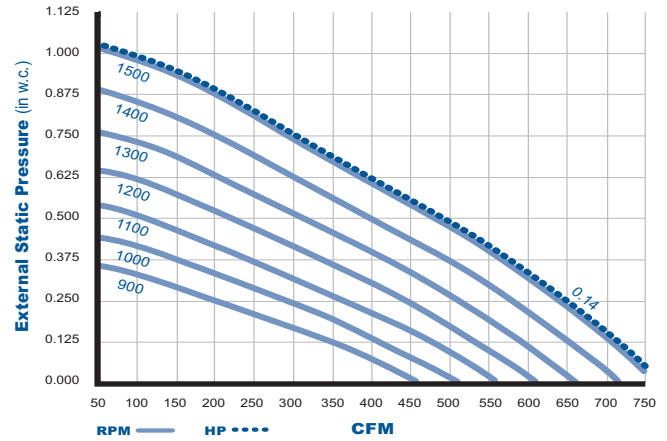

### DU25H

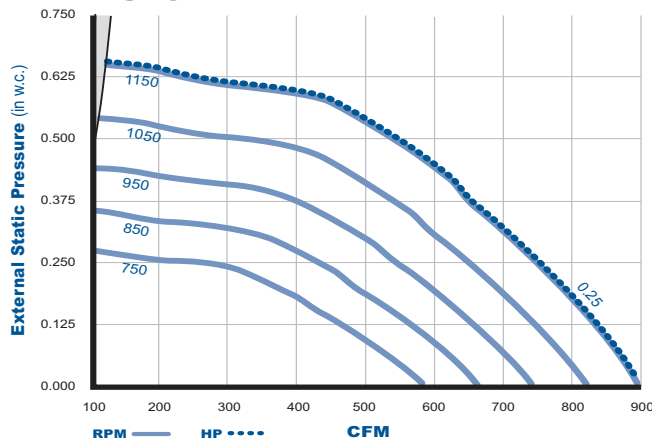

### DU30H

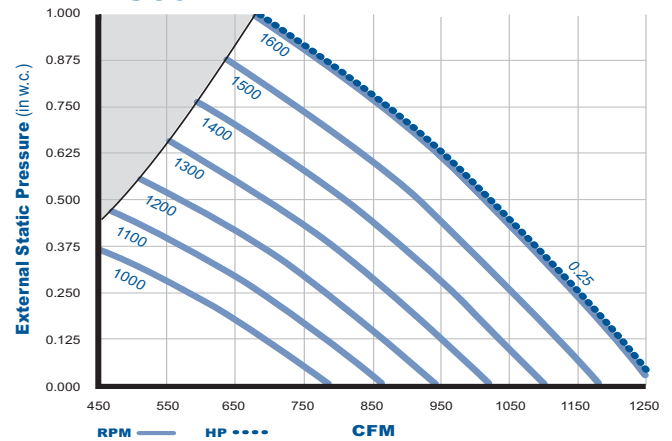

# DU

## Direct Drive - Centrifugal Up-Blast Fans

