

Multiple Applications



Water Management Solutions, Inc.

Going the extra mile starts here!™

Construction

Wellpoint

Sock Dewatering

Remediation

Recharge

Multiple Fluid Transfer

Capabilities



RotoFlo™ RWP010 10" Wellpoint Pump



MWI's RotoFlo is the perfect pump for construction dewatering, combining reliability, low operating costs, flexibility, and the best performance of any wellpoint pump on the market.

Whether you are using a wellpoint or sock system, the air/water handling capabilities of the RotoFlo will work trouble-free and with minimum use of fuel. The pump is designed to elimi-

nate the need for complicated vacuum priming, floats, and air/water separation systems, which are known for failures. When you combine this pump with WMS's 24/7 service plans, you are guaranteed a hassle-free experience. Contact us about using this pump today!

Features

- High performance (450 GPM & 210 FT. TDH)
- Dry running mechanical seals
- Pumps slurries and brackish waters
- Choice of diesel engines, electric, or hydraulically driven motors
- Integral fuel tank with gauge and lockable fuel cap
- Fuel efficient
- Pulsation free design
- Skid or trailer available
- Rotary lobes, wear plates and seals are easily replaceable on site
- Silent enclosures available (67dB @ 23 ft) for residential areas

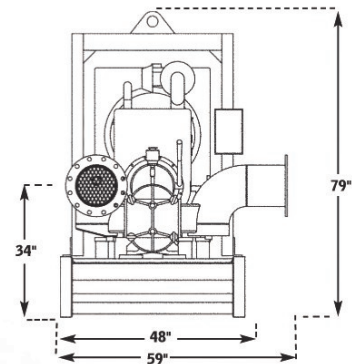
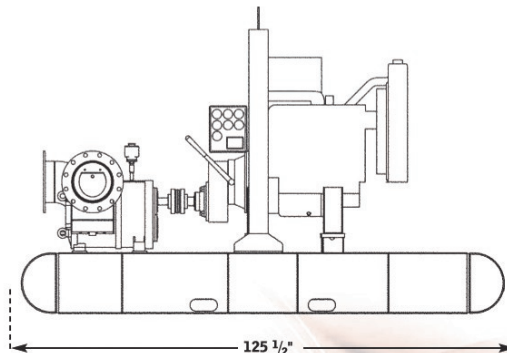

Model	Size	Max. Capacity (GPM)	Max CFM	Max Head (FT)
RWP010	10"/10"	2260	302	210



Ask us about the Silent Partner™ for your RotoFlo™ pump - a great addition for quiet pump operation.

Contact Us!

434-664-8845

mark@watermngt.com

wendy@watermngt.com

www.watermngt.com