

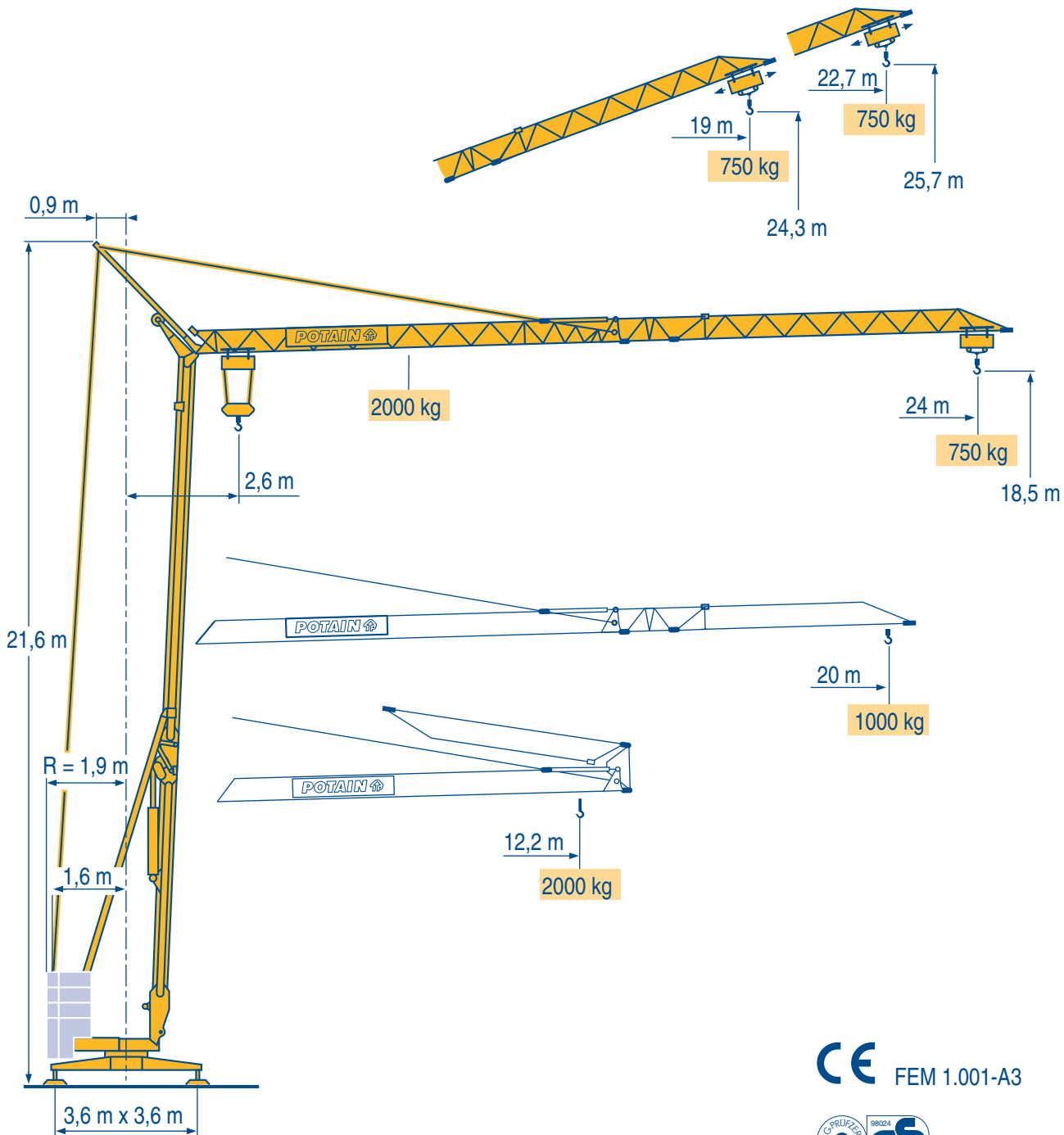

# HD 16 C



LMN 4

- Igo HD HDM
- HDT
- GTMR
- CITY CRANE
- TOPKIT MD MAXI MD
- MAXI TOPKIT
- Topless MDT
- MR

CE FEM 1.001-A3



Courbes de charges  
Lastkurven



Load diagrams  
Curvas de cargas



Curve di carico  
Curva de cargas

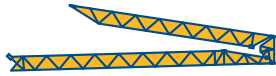

24 m	2,6 ▶	12,2 m	11,1	12	13	14	15	16	17	18	19	20	21	22	23	24 m
		2000 kg	2000	1815	1640	1490	1365	1260	1165	1085	1015	950	890	840	795	750 kg
20 m	2,6 ▶	12,2 m	11,5	12	13	14	15	16	17	18	19	20 m				
		2000 kg	2000	1905	1720	1570	1440	1325	1230	1145	1065	1000 kg				

LMN 3

Flèche relevée  
Ausleger in Steilstellung



Luffing jib  
Flecha izada



Braccio impennato  
Lança inclinada

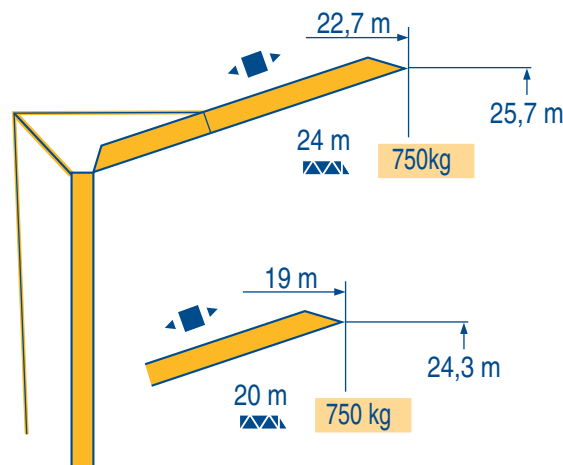

LMN 3



Chariot distributeur



Verfahrbare laufkatze



Traversing trolley



Carro distribuidor



Carrellino distributore



Carro distribuidor



HD 16 C



POTAIN

Réactions  
Eckdrücke



Reactions  
Reacciones



Reazioni  
Reações

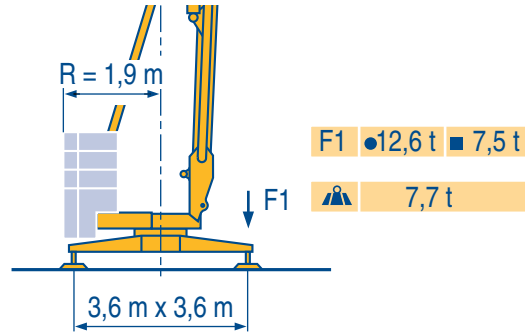

LMN 1



Réactions en service  
Réactions hors service  
A vide sans lest (ni train de transport) avec flèche et hauteur maximum



Reaktionskräfte in Betrieb  
Reaktionskräfte außer Betrieb  
Ohne Last, Ballast (und Transportachse), mit Maximalausleger und Maximalhöhe.



Reactions in service  
Reactions out of service  
Without load, ballast (or transport axles), with maximum jib and maximum height.



Reacciones en servicio  
Reacciones fuera de servicio  
Sin carga, sin lastre, (ni tren de transporte), flecha y altura máxima.



Reazioni in servizio  
Reazioni fuori servizio  
A vuoto, senza zavorra (ne assali di trasporto) con braccio massimo e altezza massima.



Reações em serviço  
Reações fora de serviço  
Sem carga (nem trem de transporte)-sem lastro com lança e altura máximas.



Mécanismes  
Antriebe



Mechanisms  
Mecanismos



Meccanismi  
Mecanismos



					ch - PS hp	kW	
	9 PC 10	m/min	6,6	20	8,2	6	
		kg	2000	2000			1000
	2 D2 V4	m/min	18 - 36			2	1,5
	RVF 30	tr/min U/min rpm	0 → 1			1,5	1,1
CEI 38		IEC 38	kVA				
400 V(+6% -10%) 50 Hz		9 PC : 12 kVA		84/534 - 87/405			

LMN 3



Levage  
Distribution  
Orientation  
Conforme aux directives CEE 84/534 et 87/405 sur le niveau acoustique



Heben  
Katzfahren  
Schwenken  
Gemäss EWG-Richtlinien 84/534 und 87/405 für den Schall-Leistungspegel



Hoisting  
Trolleying  
Slewing  
In compliance with the EEC 84/534 and 87/405 Instructions on noise level



Elevación  
Distribución  
Orientación  
Conforme con las directivas CEE 84/534 y 87/405 sobre el nivel acustico



Sollevamento  
Distribuzione  
Rotazione  
Conforme alle direttive CEE 84/534 e 87/405 sul livello acustico



Elevação  
Distribuição  
Rotação  
Conforme as directivas CEE 84/534 e 87/405 sobre o nível acústico



HD 16 C



POTAIN

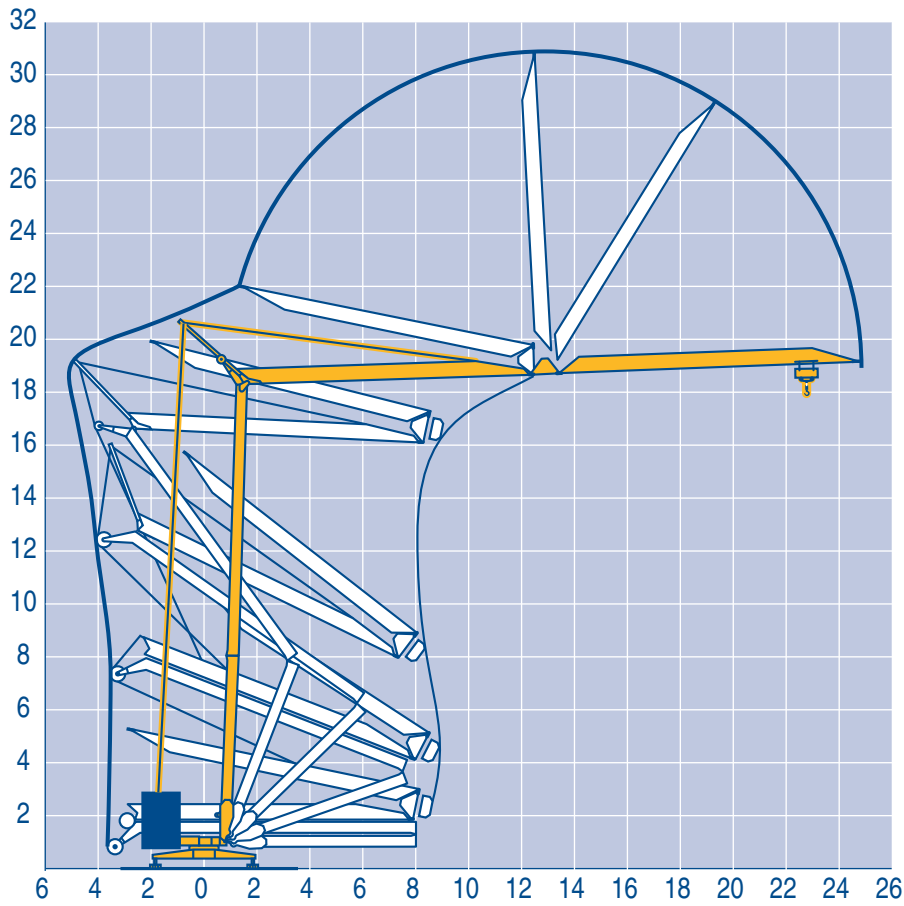

LMN 1

- DS51/S70 ○
- DS60/S80 ○
- DS60/S105
- DS95/S105
- DJ126M/S105

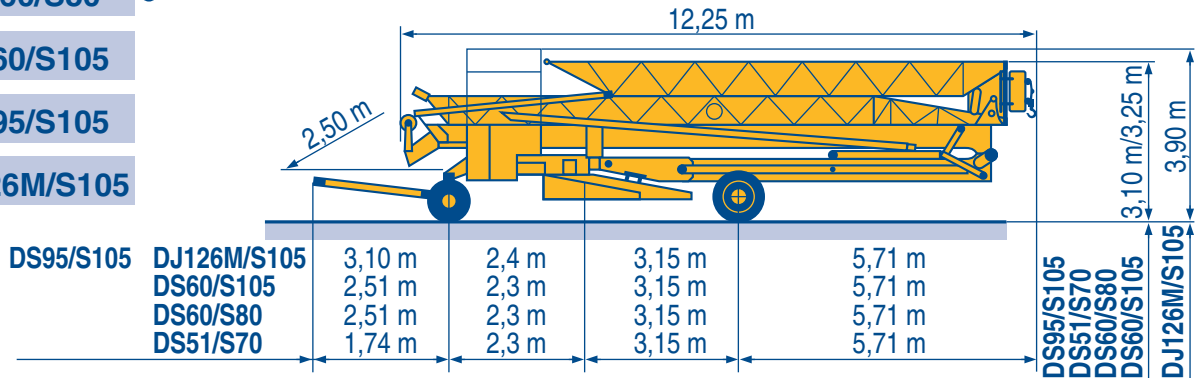

LMN 1



Document commercial non contractuel. Pour toute information technique se référer à la notice correspondante

Unverbindliches Vertriebsdokument. Für technische Informationen, siehe die entsprechenden Anweisungen.

This commercial document is not legally binding. For any technical information, please refer to the corresponding instructions.

Documento comercial non contractuel. Para cualquier información técnica, ver la noticia correspondiente.

Documento commerciale non vincolante, per tutte le informazioni tecniche fare riferimento al catalogo istruzioni

Documento comercial não contratual. Para qualquer informação técnica complementar consultar as respectivas instruções



**POTAIN**   
 18.Rue de Charbonnières, B.P. 173  
 F-69132 ECULLY Cedex  
 Tél. (33)04.72.18.20.20  
 Fax (33)04.72.18.20.00  
 http://www.potain.com  
 E-mail : mkt@potain.fr



**Deutschland**  
 POTAIN GmbH Tel : 06.1.05.70.40  
**Italia**  
 POTAIN S.p.A. Tel : 0.331.49.33.11  
**Portugal**  
 POTAIN Portugal Tel : 22.968.08.89  
**Singapore**  
 MANITOWOC POTAIN PTE LTD Tel : 227.15.50

Copyright.Reproduction interdite © POTAIN 1997

**HD 16 C**  
 Réf. 1997.44 LMN 8

Reserva de modificaciones / Modifiche riservate / Modificaciones reservadas / Subject to modification / Änderungen vorbehalten / Modifications réservées

Printed in France / Réalisation HeadLines