



## **PSI Waste Equipment Services, Inc.**



**Versa-Bale V3 SUPPORT**

**PSI Waste Equipment Services, Inc.  
31130 Industry Dr. Bldg A, Tavares, FL 32778  
Phone: 352-742-4774 Fax: 407-992-9389**

**E-mail: [repairs@psiwaste.com](mailto:repairs@psiwaste.com)**

**[www.versa-bale.net](http://www.versa-bale.net)**

# Versa-Bale V3.35

The Versa-Bale is a universal baler control system that will run virtually any vertical baler from most any manufacturer. It is a timer shifting unit and, in most cases, has smart-shift, which shifts the baler UP if it deadheads for more than a few seconds. This system is easy to install, troubleshoot, and understand. It's best to read the included information so you get the most out of your system. There are a lot of great features for field techs such as indicator lights and control buttons in the panel to bypass the remote and run the unit from the ZEN.

## Compatibility

- Marathon machines that shut off when the ram opens the gate- This is ok but you need to install a Ram UP limit switch. You'll also need to set T5 to 03.00.
- Prox switches that use 2 wires may need to actuate a relay to get the input. Call us and we'll help you out.
- If you have trouble with the motor starting immediately under load you can set T9 to 03.00.
- Any other problems, give us a call.

## Navigating the Zen Controller

- Get familiar with the ZEN by studying the drawings included. It will not only save you time, but there are a lot of great features you'll want to use. Refer to it frequently.
- You will use OK, Esc, Up, Down, Left, and Right Keys
- Most user adjustable settings are in PARAMETERS. Press OK, Select PARAMETERS using Down arrow.
- You change digits not numbers. In other words, if the number is 10 and you press down one time it will be 19 because the 0 will turn into a 9.
- When changing settings or navigating through PARAMETERS you will use OK a lot. OK indicates you want to change the setting or parameter or you are done changing the setting or parameter.

Down Time (1-2 secs less than full extension) - T0

Full Time (Time it takes to get to top of door +3sec) - T1 (decrease time for bigger bale)

Auto Shut Down (2 X T0) - T3

Max Up Time (Same as T0) - T4

These are the ONLY timers that should be set in the field.

- The loading gate MUST be opened at least 1 time between cycles. This is a safety feature to prevent the interlock from being bypassed.
- The UP button is momentary. When you let go, unit shuts off.
- There is no "Auto/ Manual"- It's not needed- simplifies operation and troubleshooting (less is more!).
- Ram must be all the way up to press start. This prevents workers from "beating up" the machine by hitting down repeatedly to get a tighter bale.
- Unit goes down on a timer and shifts before it hits the end of the stroke. As the bale gets bigger the ram will start to deadhead. If it hits pressure for 2 secs before T0 times out it will shift. This prevents the cylinder from deadheading and beating up the components in the system (cylinder head, cylinder base, piston seals, pump, hoses, etc) unnecessarily, reducing maintenance and repair.

As always, if you have any problems, please visit [www.versa-bale.net](http://www.versa-bale.net) or call me at 352-742-4774 Opt 4!

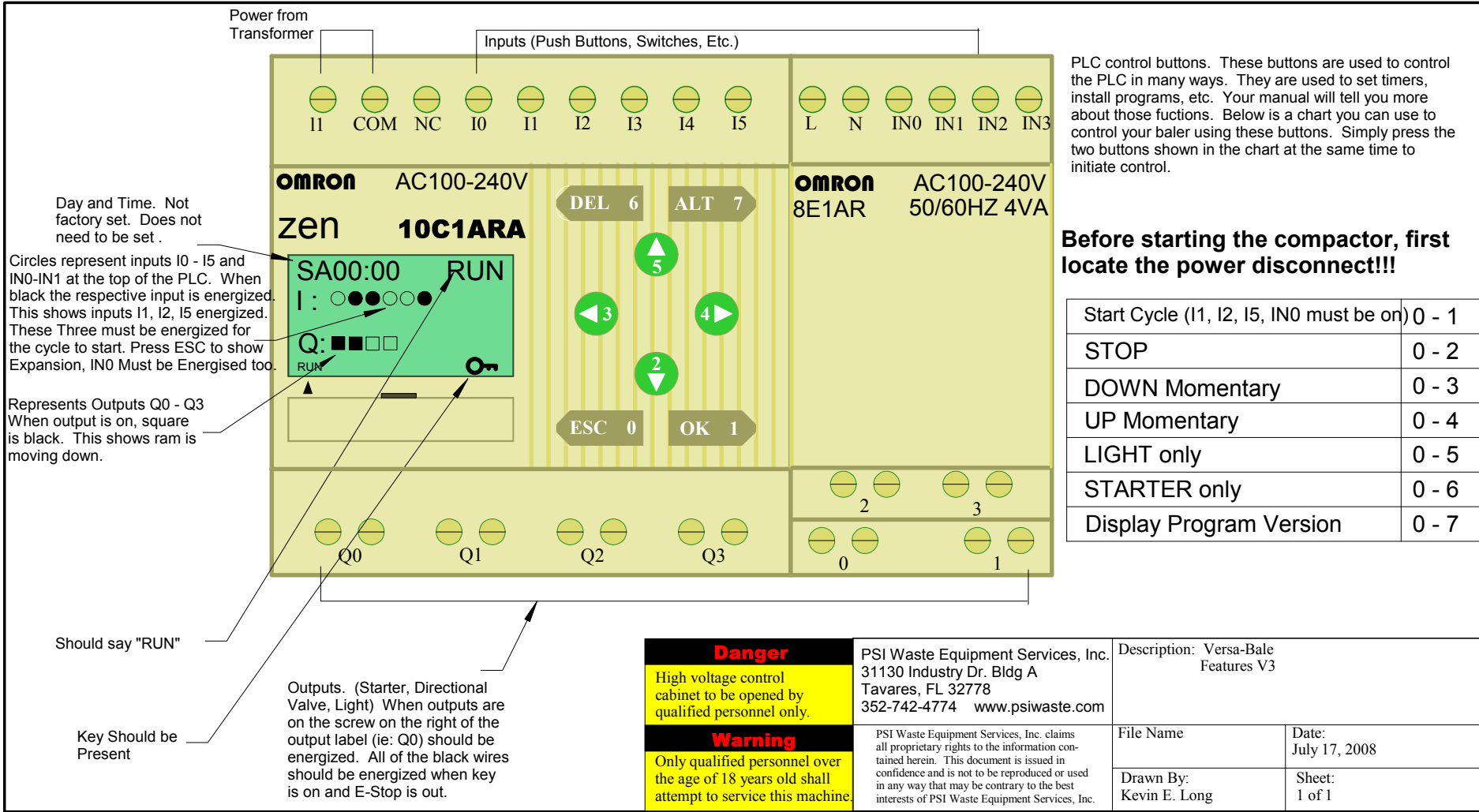

Notes:

- Must open gate between cycles or start will not work (If gate interlock is bypassed unit will not run after the 1st cycle)
- Ram must be in home (all the way up) position to start.
- UP is momentary. Can be operated any time.
- Ram stops when bale is full. Light comes on.
- If unit stops and light flashes there is an error. Check limit switches and proper operation. See if T3, 4 and 5 are set correctly.
- If ram deadheads 2 secs at full pressure before bale is ready, ram retracts.

\*\*For single phase jump T2 to L3 on starter, connect motor to T1 and T3

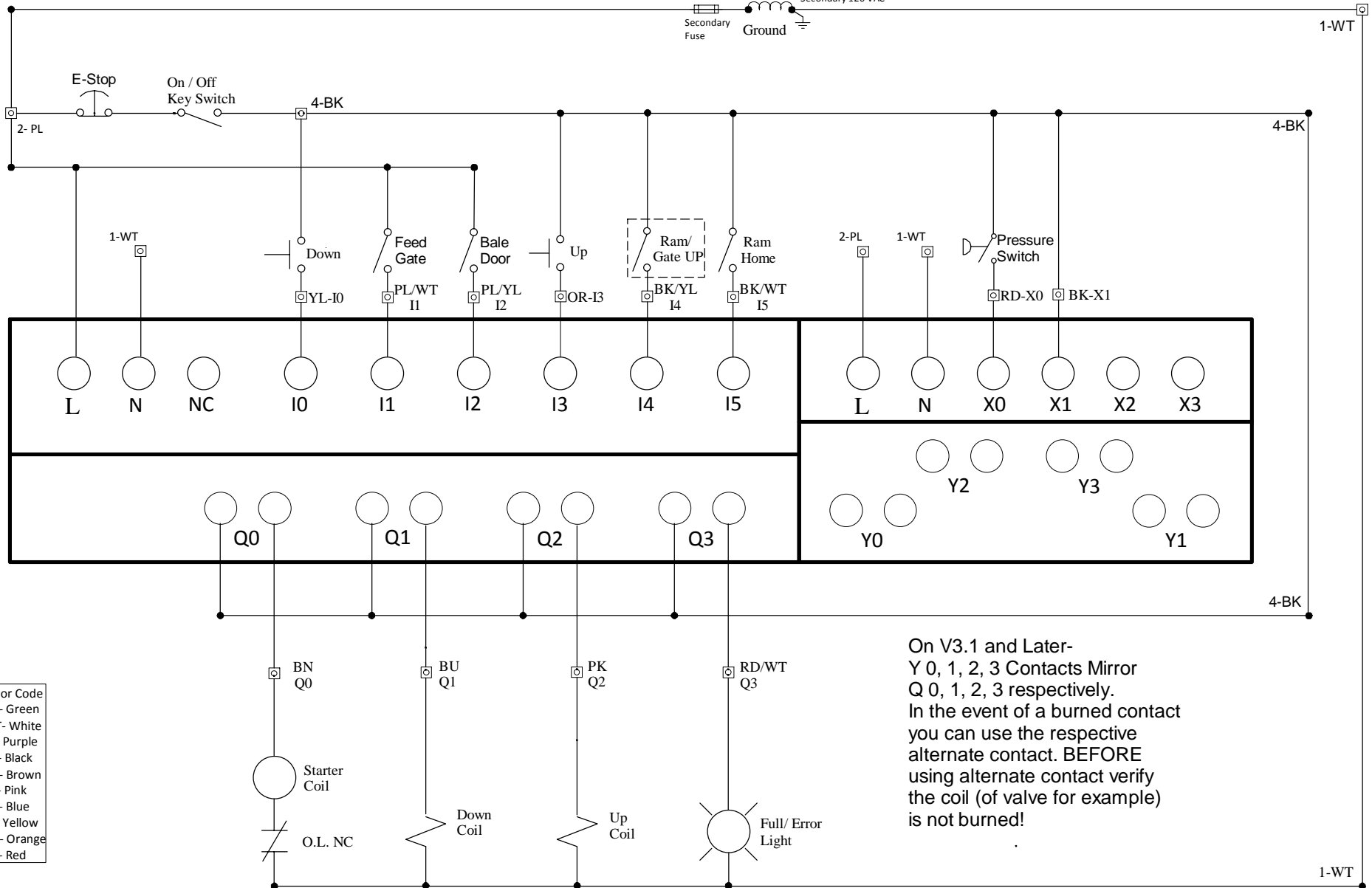
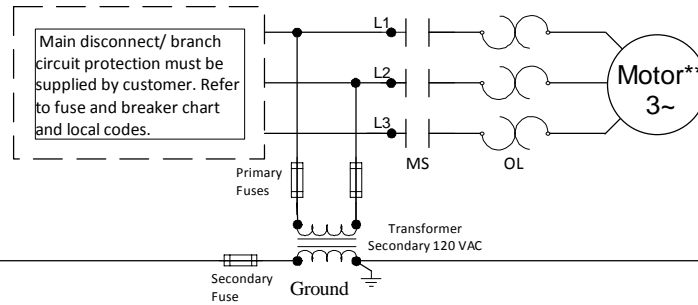

Color Code
GR- Green
WT- White
PL- Purple
BK- Black
BN- Brown
PK- Pink
BU- Blue
YL- Yellow
OR- Orange
RD- Red

On V3.1 and Later-  
Y 0, 1, 2, 3 Contacts Mirror  
Q 0, 1, 2, 3 respectively.  
In the event of a burned contact  
you can use the respective  
alternate contact. BEFORE  
using alternate contact verify  
the coil (of valve for example)  
is not burned!