

WOOTEN AUTOMOTIVE AND TOWING LLC.  
MODIFIEDS 2023 RULES

BASE WEIGHT FOR ALL CARS 2500 LBS. AT 57% LEFT SIDE WEIGHT  
ALL CARS HAVE A 4" RIDE HEIGHT

\*DEDUCT 100 LBS FOR SB SPECIFIC SHOCKS/ SPRINGS /LOCKED REAR END, PLUS  
ADD 1% LEFT SIDE WEIGHT.

\*2400 LB CARS MAX 58% LEFT SIDE WEIGHT. MINIMUM FRONT SPRING RATE 500 LBS.  
SWAY BAR MAX DIAMETER OF 1 1/8". MANDATORY LOCKED REAR END. MUST WEIGH  
A MINIMUM OF 2400 BEFORE QUALIFYING AND AFTER FEATURE.

\*2500 LB OPEN SHOCK CARS MAX 57% LEFT SIDE WEIGHT. SWAY BAR MAX  
DIAMETER OF 1 3/8"

2500 LB PLUS CARS CAN RUN SHOCKS OTHER THAN WHAT IS LISTED FOR SHADY  
BOWL CARS AND BUMP STOP TECHNOLOGY IS PERMITTED. 50 LB DEDUCTION FOR  
LOCKED REAR END. ALL MINIMUM WEIGHTS MUST BE MET BEFORE QUALIFYING  
AND AFTER FEATURE, EITHER 2450 LBS. OR 2500 LBS.

WEIGHTS AND PERCENTAGES MUST MEET REQUIREMENTS BEFORE QUALIFYING  
AND/OR AFTER 30 LAP FEATURE FOR EACH RULE PACKAGE BEING USED. FEATURE  
RACES OVER 30 LAPS WILL ALLOW 1 LB FUEL BURN OFF PER LAP OVER 30 LAPS (EX.  
50 LAPS - 20LBS.) CAUTION LAPS DO NOT COUNT.

NO TITANIUM PRODUCTS, PARTS, COMPONENTS OR GUN-DRILLED, HOLLOW BOLTS  
OR STUDS ALLOWED ON CHASSIS OR SUSPENSION.

11" MOTOR HEIGHT WILL BE MEASURED AT A 4" RIDE HEIGHT.

ALL LEAD (NO TUNGSTEN) MUST BE MOUNTED ABOVE FRAME/INSIDE FRAME RAIL  
WITH A MINIMUM OF TWO (2) 1/2 INCH BOLTS. ALL WEIGHTS MUST BE PAINTED WHITE  
OR FLORESCENT WITH THE CAR # PAINTED ON EACH PIECE. ANY DRIVER THAT  
LOSES ANY LEAD FROM THEIR CAR WILL BE FINED \$10 PER POUND PAYABLE PRIOR  
TO ANY FURTHER COMPETITION. THIS RULE IS IN EFFECT FOR ALL RACES.

MIRRORS AND RADIOS

NO MIRRORS AND/OR TWO-WAY RADIOS ARE PERMITTED IN THE CAR OR IN THE  
DRIVERS EQUIPMENT. THIS DIVISION MUST HAVE A ONE CHANNEL ONE WAY RACE  
RECEIVER FOR COMMUNICATIONS FROM RACE CONTROL AT ALL TIMES. NO OTHER  
ELECTRONIC DEVICES, CELL PHONES PERMITTED TO BE IN CAR OR ON THE DRIVERS  
PERSON. NO TRACTION CONTROL DEVICES OF ANY KIND. IF ANY TRACTION  
CONTROL DEVICE IS FOUND, THE DRIVER AND CAR OWNER WILL BE DISQUALIFIED  
FROM THE EVENT WITH LOSS OF ALL POINTS FOR THE SEASON AND A \$1000 FINE  
THAT MUST BE PAID BEFORE RACING AGAIN.

FRAME/CHASSIS

1964 OR NEWER OEM PERIMETER AMERICAN MADE REAR WHEEL DRIVE PASSENGER  
CAR FRAME ONLY. NO SPORTS CAR FRAMES. NO STRUT FRONT SUSPENSION OF  
ANY KIND ALLOWED. OEM STOCK FULL CHASSIS, CLIPS OR FABRICATED/TUBULAR  
FRAMES (MUST BE APPROVED BY TECH) REPRODUCTION 68-72 FRAME APPROVED.

2002 FORD CROWN VICTORIA OR SIMILAR FRAMES ALLOWED. SQUARE TUBE FRONT CLIPS WILL BE ALLOWED BUT MUST BE SQUARE TUBE CHASSIS/CLIPS UNALTERED HOWE PART # 358-09 OR HOWE PART # 358-10 2X4 OR 3X4 ONLY. TUBE CLIPS MUST HAVE 50 LBS IN FRONT OF FLY WHEEL. FRAME CAN NOT BE WIDENED OR NARROWED. EXCEPTIONS: WEIGHT JACK IN ORIGINAL CENTER LINE OF SPRING TOWER; FRAME MAY BE CUT A MAXIMUM 36 INCHES FORWARD FROM CENTER OF REAR HOUSING; HORNS MAY BE REMOVED IN FRONT TO STEERING BOX; FRONT CROSS MEMBER MAY BE NOTCHED AND BOXED FOR RADIATOR AND/OR STEERING CLEARANCE BUT NOT RAISED; MAXIMUM 7 INCH WIDE OPENING IN SIDE OF SPRING TOWER FOR SPRING REMOVAL. OEM UPPER A MOUNTS MAY BE REPLACED WITH AFTERMARKET MOUNTS. MINIMUM WHEELBASE 108 INCHES, MAXIMUM 112 INCHES, BOTH SIDES WITHIN 1/2 INCH OF EACH OTHER. MAXIMUM OVERALL WIDTH, FRONT AND REAR, SHALL NOT EXCEED 80 INCHES FROM OUTSIDE OF TIRE TO OUTSIDE OF TIRE AT HUB HEIGHT. NO WIDE FIVE HUBS PERMITTED. NO PART OF FRAME OF BODY SHALL BE LOWER THAN 4 INCHES FROM GROUND, EXCEPT THE FRONT CROSS MEMBER, IN RACE TRIM. LEFT SIDE FRAME RAIL MUST RUN TO INTERIOR FOOT BOX.

( THIS IS NOT AN OPPORTUNITY TO BE CREATIVE!)

#### SUSPENSION AND STEERING

1. STEERING: NO RACK AND PINION. ALL COMPONENTS MUST BE STEEL, UNALTERED OEM, IN OEM LOCATION. EXCEPTIONS: TIE ROD ENDS AND ADJUSTER SLEEVES MAY BE REPLACED BY A MINIMUM .625 INCH STEEL ROD ENDS AND STEEL OR ALUMINUM TUBES; OEM SPINDLES CAN BE MODIFIED FOR BALL JOINTS AND TIE ROD ENDS; PASSENGER CAR DROP SPINDLES ALLOWED BUT MUST BE SAME DROP PER SIDE; (NO MADE FOR RACING OR FABRICATED SPINDLES ON 2400 LB CARS.)

2500 LB CARS OEM AND FABRICATED SPINDLES PERMITTED, MUST BE STEEL. BOTTOM A-FRAMES CAN NOT BE ALTERED OR MOVED. BOLT ON SPINDLE SAVERS ALLOWED; SPINDLES MUST BE RIGHT AND LEFT, AND OF THE SAME DESIGN; STEEL STEERING SHAFTS AND KNUCKLES ONLY; STEERING QUICKNER, STEERING WHEEL AND QUICK RELEASE MAY BE ALUMINUM; DRIVER COMPARTMENT STEERING MAY BE MODIFIED, BUT MUST BE KEPT ON LEFT SIDE. OEM CENTER LINK OR OEM AFTERMARKET TYPE CENTERLINKS ALLOWED.

2. FRONT SUSPENSION: ALL COMPONENTS MUST BE STEEL, UNALTERED OEM, IN OEM LOCATION, AND REPLACEABLE BY OEM PARTS. EXCEPTIONS: TIE ROD SLEEVES OR TUBES CAN BE ALUMINUM. TUBE TYPE UPPER A-FRAMES WITH OR WITHOUT ALUMINUM OR STEEL CROSS SHAFT, AND MOUNTS CAN BE MOVED; STAMPED STEEL OEM REPLACEMENT LOWER A-FRAMES; RUBBER, NYLON, OR STEEL LOWER A-FRAME BUSHINGS; NO OFFSET BUSHINGS; WELDED OR BOLTED SHOCK MOUNTS ON LOWER A-FRAMES. LOWER A-FRAMES MUST BE RIGHT AND LEFT, AND OF THE SAME DESIGN. "NO MANIPULATION" OF LOWER A-FRAME MOUNTS AND BOLT HOLES ON FRAME MUST BE IN OEM LOCATION. "NO MANIPULATION" . OEM TYPE BALL JOINTS ONLY. SWAY BAR MUST BE OEM TYPE, NO SPLINED BARS.

3. SPRINGS/FRONT: MINIMUM OF 500 LB. SPRING RATE AND ABSOLUTELY NO BUMP-STOPS (ON CARS THAT WEIGH 2400 LBS.) ALL CARS- NO COIL BINDING, SHORT SHOCK SHAFTS OR CHASSIS STOPS OF ANY TYPE. CARS WILL BE CHECKED

BY PUTTING FRONT TIRES ON 1/2" BLOCKS AND CROSS MEMBER/NOSE ON THE GROUND. SPRING HEIGHTS MINIMUM 10". .5" DIAMETER MINIMUM. NO TENDER/PROGRESSIVE RATE SPRINGS. NO TAKE UP SPRINGS OF ANY KIND. 1 SPRING PER WHEEL ONLY. ALL SPRINGS MUST BE VISIBLE/NO COVERS. NO TORSION BARS OR AIR BAGS.

4. SPRINGS/REAR: STEEL COIL SPRINGS OR STEEL LEAF SPRINGS ONLY. COIL OVER KITS WITH MINIMUM OF 4.5" SPRINGS ON REAR ONLY. A MAXIMUM 2 SPRING RUBBERS ALLOWED PER SPRING. NO DRIVER ADJUSTMENTS WILL BE ALLOWED FROM COCKPIT EXCEPT BRAKE BIAS KNOB.

5. REAR SUSPENSION: NO INDEPENDENT REAR SUSPENSION. ALL COMPONENTS MUST BE STEEL. NO COVERS ALLOWED. ALL TRAILING ARMS/LINK BARS MUST BE MADE OF STEEL TUBING. REAR OF FRAME MAY BE ALTERED TO ACCEPT LEAF OR COIL SPRINGS. PULL BAR MAY UTILIZE SMALLER O.D. SPRING. ONE (1) MECHANICAL TRACTION BAR ONLY. NO REAR SWAY BARS. ALUMINUM PANHARD BAR ADJUSTER ALLOWED. NO BIRD CAGE TYPE SUSPENSION OR MULTIPLE MOUNTING POINTS.

WISH BONE, 4 LINK, OR ANY ACTIVE SYSTEM IS NOT ALLOWED. RACE TRACK RESERVES ALL RIGHTS TO APPROVE/DISAPPROVE ANY SYSTEM. WEIGHT PENALTIES MAY APPLY.

6. SHOCKS: (2400 LB. CARS ONLY) (SHADY BOWL SPECIFIC SHOCK RULES FOR 100 LB. WEIGHT BREAK) STEEL, FACTORY SEALED, NON-REBUILDABLE. PRO WB SERIES OR AFCO #14 SERIES ONLY. RATES 3 THROUGH 5, 50/50 VALVING. NO SPLIT VALVE SHOCKS. 7" OR 9" LENGTHS ALLOWED. RIGHT FRONT SHOCK MUST BE HEAVIEST RATE. ONE (1) SHOCK PER WHEEL, WITH ONE (1) ADDITIONAL SHOCK ALLOWED IN THE LIFT/PULL BAR AREA. NO AIR SHOCKS. NO SHOCK COVERS. NO CHASSIS LIMITING DEVICES..(EX. FRAME STOPS, FRAME EXTENSIONS) ABSOLUTELY NO BUMP STOPS. FINE FOR LIMITING DEVICES WILL BE THE SAME AS SHOCK ALTERING.

SHOCK CLAIM: (2400 LB. CARS ONLY) SHOCKS CAN BE CLAIMED BY RACE TRACK OR AN OTHER DRIVER FINISHING IN THE TOP 5 IN COMPETITION IN THIS CLASS THAT NIGHT FOR \$100 PER SHOCK.

NO SALE PENALTY: \$250.00 FINE, LOSS OF POINTS AND MONEY FOR THAT NIGHT, CAN NOT COMPETE IN THE FOLLOWING TWO (2) RACES,(RAIN OUT DO NOT COUNT) AND THEN CAN NOT COMPETE UNTIL SHOCKS HAVE BEEN TECHED AND FOUND TO BE LEGAL.

ALTERING SHOCKS: 1ST OFFENSE...\$250.00 FINE PLUS CAN NOT COMPETE IN THE FOLLOWING TWO (2) RACES, (RAIN OUTS DO NOT COUNT) 2ND OFFENSE...\$1000.00 FINE PLUS ONE (1) YEAR SUSPENSION.

(OPEN SHOCK RULES): (2500 LB. CARS ONLY) ONE (1) SHOCK PER WHEEL MAY BE STEEL OR ALUMINUM . ALL SHOCKS MUST BE NON-ADJUSTABLE OR SINGLE ADJUSTABLE ONLY. SINGLE SHAFT BLEED ADJUSTMENT THROUGH A TAPERED NEEDLE INTO A JET IN THE HOLLOW SHAFT ALLOWED. NO BLOW OFF SHAFTS OR HIGH SPEED REBOUND SHAFTS ALLOWED. NO EXTERNAL RESERVOIRS OF ANY KIND. (BUMP STOP TECHNOLOGY PERMITTED) ANY CAR WITH NO BUMP STOPS MAY BE CHECKED FOR LIMITING DEVICES BY PUTTING FRONT TIRES ON 1/2" BLOCKS AND CROSS MEMBER/NOSE ON GROUND.

ALTERING OF A MANUFACTURING PART NUMBER(S) WILL NOT BE PERMITTED. ANY PART FOUND WITH AN ALTERED PART NUMBER(S) WILL BE DISALLOWED IN COMPETITION. NO GRINDING OFF PART NUMBERS OR PAINTING SPRINGS OR SHOCKS. ALL MUST MAINTAIN ORIGINAL PAINT AND COLOR BY MANUFACTURER. THE TRACK INSPECTION EQUIPMENT USED BY AN OFFICIAL WILL BE THE STANDARD OF THE RACE TRACK AND ALL TESTS WILL BE FINAL.

7. REAR END: ANY STEEL APPROVED OEM PASSENGER CAR OR TRUCK REAR END ALLOWED. CLOSED, STEEL TUBE QUICK CHANGES ALLOWED. SAFETY HUBS (FLOATER) MANDATORY. STEEL AXLES ONLY. NO CAMBERED REAR ENDS. ONE (1) PIECE DRIVE FLANGE ONLY. ALL COMPONENTS MUST BE STEEL. EXCEPTIONS: LOWERING BLOCKS, AXLE CAPS, ROTOR PLATES, AND DRIVE FLANGES. NO ALUMINUM HUBS PERMITTED.

8. BRAKES: FRONT AND REAR BRAKES MUST CONSIST OF STOCK APPEARING COMPONENTS ONLY, SINGLE PISTON AND MUST LOCK UP ALL FOUR (4) WHEELS. DUAL PISTON ADD 25 LBS.

9. ROTORS: OEM OR HOWE STEEL 2 PIECE ROTOR AND HUB PART # 205351-IMPALA OR PART # 205350-PINTO. NO SCALLOPED OR DRILLED ROTORS, SIMILAR THICKNESS AS OEM ONLY.

#### ROLL CAGE

MUST CONSIST OF CONTINUOUS HOOPS, MINIMUM 1.75 INCH O.D. TUBING, WITH A MINIMUM WALL THICKNESS OF .095 INCH FOR MAIN CAGE. FRAME MOUNTED IN AT LEAST 6 PLACES, LOW CARBON OR MILD STEEL RECOMMENDED. MUST CONSIST OF A CONFIGURATION OF FRONT, REAR AND TOP HOOPS CONNECTED BY TUBING ON THE SIDES OR SIDE HOOPS. DRIVERS HEAD MUST NOT PROTRUDE OUTSIDE CAGE WITH HELMET ON. ROLL CAGE MUST BE SECURELY SUPPORTED AND BRACED WITH MINIMUM 1 CROSS BAR IN TOP HALO. FOOT PROTECTION BAR(S) REQUIRED. MAIN CAGE NO FURTHER FORWARD THAN REAR OF ENGINE. ALL BARS FORWARD OF THE CAGE MUST BE LOWER THAN THE HOOD.

#### DOOR BARS

ALL DRIVER SIDE DOOR BARS AND UPRIGHTS MUST BE A MINIMUM 1.75 INCH AND .095 INCH WALL THICKNESS. MINIMUM 4 DRIVER SIDE DOOR BARS, PARALLEL TO THE GROUND AND PERPENDICULAR TO THE DRIVER, AND WELDED TO THE FRONT AND REAR ROLL CAGE. PASSENGER SIDE MUST HAVE AT LEAST 1 CROSS DOOR BAR, HORIZONTAL OR ANGLED, AND 1 TOP DOOR BAR, MINIMUM 1.5 INCH O.D. STEEL DOOR PLATE, 16 GAUGE (.065) MINIMUM THICKNESS, MUST BE SECURELY WELDED TO OUTSIDE OF THE DRIVER SIDE DOOR BARS AND COVER THE AREA FROM TOP DOOR BAR TO BOTTOM DOOR BAR AND FROM REAR HOOP DOWN POST TO FRONT CAGE DOWN POST.

#### BODY

1. FULL ROOF IS MANDATORY AND MUST COVER COMPLETE HALO BAR. NO DRIP RAILS ALLOWED. BODIES MUST BE ALUMINUM OR FIBERGLASS ONLY. NO CARBON FIBER OR PLASTIC, EXCEPT NOSE. TOPS CAN BE ALUMINUM OR FIBERGLASS NOT BOTH.

2. BODY SIDES MUST MOUNT STRAIGHT ON CHASSIS (PARALLEL TO OEM FRAME) (MEASURED WITH 6' STRAIGHT EDGE ON RR (RIGHT REAR) WHEEL AND BE EQUAL), WITH A MAXIMUM LENGTH OF 120" STARTING FROM BACK OF ENGINE, MAXIMUM WIDTH OF 66" AND MAXIMUM BODY RAKE OF 6" MUST BE STRAIGHT FRONT TO REAR AND FLAT.

3. SAIL PANELS MUST BE STRAIGHT FROM ROOF TO QUARTER PANEL AND END AT LEAST 2 INCHES FROM SPOILER.

4. 12" X 18" WINDOW OPENING (HEIGHT AND WIDTH) MEASURED AT CENTER OF WINDOW. BETWEEN LOWEST POINTS AT TOP OF WINDOW WHETHER ROOF OR ROLL CAGE AND THE HIGHEST POINT AT BOTTOM OF WINDOW WHETHER INTERIOR OR BODY.

5. NOSES:

ALUMINUM YOU MUST RUN FULL UPPER AND LOWER NOSE. YOU MAY RUN A MAXIMUM 1.50 INCH LIP ON THE TOP SIDES OF NOSE, AND 3 INCHES AROUND THE BOTTOM OF NOSE.

PLASTIC NOSE PERMITTED IF THEY MEET BODY DIMENSIONS OUTLINED BELOW.

A. ALL CARS MUST RUN FULL UPPER AND LOWER NOSE.

B. NOSES WILL BE ALLOWED A MAXIMUM 3" FRONT LOWER VALANCE/SPLITTER AROUND THE BOTTOM OF THE NOSE.

ALL CARS MAXIMUM FRONT NOSE/BUMPER LENGTH IS 42 INCHES FROM CENTER OF FRONT WHEEL.

6. REAR MEASUREMENT FROM CENTER OF WHEEL TO END OF BODY MAXIMUM 48".

7. A 12" MAXIMUM LENGTH TRIANGULAR ENCLOSURE AT THE "A" PILLAR WILL BE ALLOWED. NO INTERIOR OR EXTERIOR WINGS, BELLY PANS, DOUBLE SKINNED ROOFS, FINS, WINGS, VANES, VERTICAL LEDGES, RAMPS OR ANY OTHER AIR DIRECTING DEVICES ARE PERMITTED.

8. ENGINE COMPARTMENT MUST REMAIN OPEN. ALL CARS MUST HAVE STEEL SIDE NERF BARS MOUNTED EVEN WITH OUTSIDE OF TIRE. MUST MAINTAIN 4" GROUND CLEARANCE AT ALL TIMES.

9. 8" PANEL REQUIRED IN REAR / 90 DEGREES TO THE GROUND. MUST BE SOLID, ATTACHED TO THE DECK AND EXTEND TO THE QUARTER PANELS, SECURELY FASTENED. MUST DISPLAY CAR NUMBER.

10. SPOILER:

\*OPTION 1: 5" X 60" REAR SPOILER CENTERED ON BODY WITH MAXIMUM OF 4 STRAIGHT FORWARD BRACES NO LONGER THAN 16 " AND NO TALLER THAN SPOILER. MAY USE REAR "LATE MODEL" BRACES. GURNEY FLAPS OR CURLS ARE ALLOWED BUT WILL BE INCLUDED IN ALL MEASUREMENTS. CLEAR POLY CARBONATE OR "LEXAN" SPOILERS HIGHLY RECOMMENDED.

\*\*OPTION 2: 4 " X 66" REAR SPOILER 45 DEGREE TO THE DECK IS ALLOWED WITH ALL BRACES TO THE REAR OF SPOILER.

11. BUMPERS: HEIGHT 20" MAX - 16" MIN (GROUND TO CENTER OF BUMPER FRONT AND REAR.)

12. DRIVER COMPARTMENT: MUST HAVE A MINIMUM 3 WINDSHIELD BARS IN FRONT OF DRIVER. (NO FULL WINDSHIELDS) LEXAN OR ALUMINUM COWL PANEL IN FRONT

OF THE DRIVER CAN BE NO WIDER THAN THE COCKPIT AND NO FARTHER BACK THAN THE STEERING WHEEL. MINIMUM .125" ALUMINUM, OR 22 (.035") GAUGE STEEL, COMPLETE FLOOR PLAN REQUIRED. MANDATORY ALUMINUM HIGH BACK SEAT ONLY (FULL CONTAINMENT SEAT HIGHLY RECOMMENDED) AND MUST BE BOLTED IN SECURELY, INSIDE THE LEFT OEM FRAME AND AHEAD OF THE REAR TIRES. BOTTOM OF SEAT CAN BE NO LOWER THAN BOTTOM OF FRAME. (NASCAR STYLE RIGHT AND LEFT HEAD, SHOULDER SUPPORTS AND LEG RESTRAINTS HIGHLY RECOMMENDED.)

DRIVER MUST BE SEALED OFF FROM TRACK, DRIVE LINE, ENGINE, FUEL CELL, BATTERY AND PUMPS. NO DRIVER ADJUSTABLE DEVICES ALLOWED IN COCKPIT EXCEPT BRAKE ADJUSTERS. NO ACCUSUMP SYSTEMS MOUNTED IN DRIVERS COMPARTMENT.

13. GAUGES/ELECTRONICS: NO ELECTRONIC MONITORING COMPUTER DEVICES CAPABLE OF STORING OR TRANSMITTING INFORMATION IS PERMITTED. EXCEPTION: ANALOG TACH. NO ADJUSTABLE IGNITION CONTROL BOXES. ONE (1) 12/16 VOLT IGNITION BOX ALLOWED, WITH REV CHIP. ANY REV LIMITER MUST HAVE A STRAIGHT LINE TIMING CURVE, MUST BE OUT OF REACH OF DRIVER. NO ADDITIONAL IGNITION ACCESSORIES ALLOWED. NO MAGNETOS. NO TRACTION CONTROL DEVICES. ALL BODY RULES ARE AT THE DISCRETION OF TECH OFFICIALS AND MUST BE MET OR A MINIMUM OF 50 LBS. PER INFRACTION MAY BE ACCESSED.

#### ENGINE

ANY AMERICAN MADE ENGINE ALLOWED. STEEL BLOCK. NO MACHINE WORK TO THE OUTSIDE OF BLOCK (LIGHTENING). MINIMUM OIL PAN DEPTH IS 6 1/2 ". ONE (1) NATURALLY ASPIRATED TWO (2) OR FOUR (4) BARREL CARBURETOR ONLY. (NO FUEL INJECTION). NO MAGNETOS. INTAKE MUST BE STEEL OR ALUMINUM. NO DRY SUMP SYSTEMS ALLOWED. SINGLE STAGE EXTERNAL PUMP ALLOWED. (NO EXTERNAL TANKS)

#### ENGINE COMPARTMENT

REAR OF ENGINE MUST BE MOUNTED AT LEAST 72" FORWARD FROM CENTERLINE OF REAR AXLE. ENGINE OFFSET MUST BE KEPT WITHIN 2" OF CENTERLINE OF FRONT CROSS MEMBER WITH ENGINE LEVEL. MINIMUM 11" FROM CENTERLINE OF CRANK SHAFT TO GROUND. RADIATOR MUST BE MOUNTED IN FRONT OF ENGINE. COOLING SYSTEM MAY BE MODIFIED. NO ANTI-FREEZE.

#### EXHAUST

ROUND TUBE HEADERS ONLY. ALL PRIMARY TUBES MUST ENTER INTO 1 COLLECTOR AT THE END OF THE HEADER. MUFFLERS REQUIRED. RIGHT SIDE EXHAUST MUST EXIT UNDER THE CAR. (NOT OUT RIGHT SIDE DOOR.)

#### TRANSMISSION

MUST HAVE AT LEAST TWO (2) FORWARD GEARS AND ONE (1) REVERSE GEAR, PLUS A NEUTRAL POSITION. WITH ENGINE RUNNING AND CAR IN STILL POSITION, MUST BE ABLE TO ENGAGE CAR IN GEAR AND MOVE FORWARD, THEN BACKWARD. OEM PRODUCTION TYPE OR APPROVED AFTERMARKET TRANSMISSIONS (BERT, BRINN, FALCON) ALLOWED.

(2-SPEED, 3-SPEED, 4-SPEED AND AUTOMATIC) NO 5-SPEED OR MORE TRANSMISSIONS. NO "IN AND OUT" BOXES ALLOWED. STANDARD CLUTCH TYPE

TRANSMISSIONS MUST HAVE A BLOW PROOF BELL HOUSING (STEEL OR ALUMINUM).  
AUTOMATIC TRANSMISSIONS MUST HAVE AN APPROVED SCATTER SHIELD.

#### DRIVE SHAFT

MINIMUM 2.5" DIAMETER, STEEL OR ALUMINUM DRIVE SHAFT, PAINTED WHITE. STEEL  
SLIP-YOKES ONLY. 360 DEGREE DRIVE SHAFT LOOP REQUIRED AND MUST BE  
CONSTRUCTED OF AT LEAST .25" BY 2" STEEL OR EQUIVALENT, MOUNTED 6" BACK  
FROM FRONT U-JOINT.

#### FUEL SYSTEM

MECHANICAL OR BELT DRIVEN PUMP ONLY AND MUST BE MOUNTED ON FRONT OF  
MOTOR. RACING FUEL CELL REQUIRED, 22 GALLON MAXIMUM CAPACITY, SQUARE OR  
RECTANGLE IN SHAPE (NO TEAR DROP, WEDGE, OR EXOTIC F-1 TYPE FUEL CELLS  
ALLOWED) MUST BE IN A MINIMUM 22 GAUGE STEEL CONTAINER. CELL MUST BE  
SECURELY MOUNTED BEHIND THE REAR AXLES AND BETWEEN THE REAR TIRES.  
CELL MUST BE NO LOWER THAN BOTTOM OF REAR END HOUSING. CELL MUST BE  
MOUNTED WITH A MINIMUM 2 SOLID STEEL STRAP AROUND ENTIRE CELL, 2 INCHES  
WIDE AND .125 INCHES THICK OR EQUIVALENT. ALL CELL MOUNTS MUST BE STEEL  
AND SECURELY WELDED OR BOLTED TO THE FRAME. PROTECTIVE TUBING MUST  
COVER REAR OF CELL AND EXTEND PAST BOTH ENDS OF THE CELL. NO PART OF THE  
CELL IS TO LOWER THAN THE PROTECTIVE TUBING. VENTS AND LIDS MUST HAVE  
CHECK VALVES. FUEL LINE PICK UP MUST BE ON TOP OF CELL. NO COOL CAN AND  
(1) FUEL FILTER ONLY.

#### FUEL

RACING GASOLINE. NO ALCOHOL ALLOWED

#### BATTERY/STARTER

ONE 12/16 VOLT BATTERY ONLY, MUST BE SECURELY MOUNTED BETWEEN FRAME  
RAILS, BEHIND CROSS MEMBER, IN FRONT OF REAR END AND OUTSIDE OF DRIVER  
COCKPIT, WITH POSITIVE TERMINAL COVERED.

CAR MUST HAVE THE CAPACITY OF STARTING WITHOUT BEING PUSHED OR PULLED.  
STANDARD OR REVERSE MOUNT STARTERS ALLOWED.

#### WHEELS

EIGHT (8) INCH STEEL WHEEL ONLY, MEASURED FROM INSIDE BEAD TO INSIDE BEAD.  
NO BEAD LOCKS, SCREWS, OR RIM MOUNTED BLEEDER VALVES. STEEL AND  
ALUMINUM WHEEL SPACERS ARE ALLOWED.

#### TIRES

AMERICAN RACER 970 (UNLESS OTHERWISE TOLD BY TECH) (PURCHASED AT SHADY  
BOWL). NO SOFTENING, SOAKING, CONDITIONING, SIPPING, OR GROOVING OF TIRES.  
NO RE-CAPS. SOAKING OF TIRES IS STRICTLY PROHIBITED. (THIS RULE APPLIES TO  
ALL TIRES IN THE PITS, ON THE CAR, IN THE TRAILER OR HAULER, ALL TIRES) TIRES  
MAY BE CHECKED AT ANY TIME. ALL RACE TIRES MUST HAVE BABY POWDER IN  
THEM. AFTER FEATURE THE TOP 3 FINISHERS, ALONG WITH UP TO 3 RANDOM CARS  
MAY BE ASKED TO BREAK DOWN ONE (1) OR TWO (2) TO CHECK FOR POWDER. TIRE  
SAMPLES MAY BE SENT OUT TO A LAB FOR TESTING. IF TIRES ARE FOUND BY LAB TO  
BE ALTERED, DRIVER WILL LOSE ALL POINTS FOR THE SEASON, ALL MONEY FOR THE

NIGHT, 4 RACE SUSPENSION,(RAIN OUTS DO NOT COUNT) AND \$500 FINE TO BE PAID BEFORE DRIVER OR CAR CAN RETURN TO RACE.

ONE (1) NEW TIRE PER NIGHT OF RACING.

#### NUMBERS/DECALS

ALL NUMBERS MUST BE IN CONTRASTING COLOR FROM BODY, AFFIXED TO BOTH DOORS AND TOP, BE AT LEAST 4 INCHES THICK AND 20 INCHES TALL, AND BE READABLE FROM THE PASSENGER SIDE OF CAR. COMPETITORS ARE TO RESERVE THE FRONT 24 INCHES OF EACH DOOR AND THE FIRST 6 INCHES OF THE ROOF FOR SANCTIONING BODY AND/OR TRACK SPONSORS.

#### SAFETY EQUIPMENT

SNELL-RATED SA2015 OR NEWER HELMET IS MANDATORY. ROLL BAR PADDING MANDATORY IN DRIVERS COMPARTMENT (FIRE RETARDANT HIGHLY RECOMMENDED) SFI FULL FIRE SUIT IS MANDATORY. FIRE RETARDANT NECK BRACE, GLOVES AND SHOES MANDATORY. (FIRE RETARDANT HEAD SOCK AND UNDERWEAR; HEAD AND NECK RESTRAINTS; COLLAPSIBLE STEERING SHAFT; HIGHLY RECOMMENDED) DRIVER SIDE WINDOW NET MANDATORY AND MUST BE MOUNTED SO THAT THE LATCH IS AT THE TOP FRONT OF WINDOW. MINIMUM THREE (3) INCH WIDE, FIVE POINT SAFETY BELT ASSEMBLY MANDATORY AND MUST BE MOUNTED SECURELY TO THE ROLL CAGE AND MUST BE LESS THAN 3 YEARS OLD. FIRE EXTINGUISHER HIGHLY RECOMMENDED (MINIMUM 10 LB. FIRE EXTINGUISHER IN PIT AREA) KILL SWITCH MANDATORY AND WITHIN EASY REACH OF DRIVER AND MUST BE MARKED "OFF" AND "ON". ANY VARIANCE OF THESE RULES BY PARTICIPANTS THAT MAY ULTIMATELY LEAD TO REDUCTION IN SAFETY, OR AN INCREASED RISK TO ANY PARTICIPANT, WHETHER ENFORCED BY THE CHIEF TECH INSPECTOR OR OTHERWISE, SHALL BE THE EXCLUSIVE RESPONSIBILITY AND LIABILITY OF THE PARTY OR PARTIES RESPONSIBLE FOR THE VARIANCE. THE MANAGEMENT OF THE SPEEDWAY AND THE PROMOTERS SHALL NOT BE RESPONSIBLE OR LIABLE FOR ANY VARIANCE FROM THESE RULES AS PROVIDED. TRACK OFFICIALS MUST APPROVE ALL SAFETY EQUIPMENT.

RULE ENFORCEMENT: THE CHIEF TECH INSPECTOR SHALL BE AUTHORIZED TO MAKE CHANGES FROM ANY SPECIFICATIONS CONTAINED WITHIN THESE RULES AS A SITUATION MAY DICTATE. ANY INFRACTION NOT SPECIFIED IN THESE RULES MAY INCUR A WEIGHT PENALTY. FURTHERMORE, THE CHIEF TECH INSPECTOR MAY IMPOSE RESTRICTIONS IN AN ATTEMPT TO MAINTAIN FAIRNESS. UNDER NO CIRCUMSTANCES MAY THE TECH INSPECTOR ALTER ANY SAFETY RULE TO LESS THAN STIPULATED. CARS MUST QUALIFY AND RACE ON THE SAME TIRES. A USED TIRE OUT OF YOUR "RACE TIRES INVENTORY" (SEE TIRE RULES) MAY BE USED IN CASE OF A FLAT.

RULES ARE SUBJECT TO CHANGE. ANY PART FOUND TO BE ILLEGAL COULD BE CONFISCATED BY TECH AND BECOME PROPERTY OF THE SPEEDWAY IF TECH SO DESIRES. IF CAR IS FOUND ILLEGAL AT POST RACE TECH (EXCLUDING TIRES) DRIVER WILL LOSE ALL POINTS AND ONLY RECEIVE TOW MONEY FOR THE NIGHT. ASPHALT BODY DIAGRAM AND DIMENSIONS (DIAGRAM PICTURED BELOW)



- A. 20" MAX. - 16" MIN. (GROUND TO CENTER OF BUMPER FRONT AND REAR)
- B. 6.5" MIN. (CENTER TO CENTER)
- C. 52" MAX. - 42" MIN.
- D. 6" MAX. HOOD SIDES - 3" MAX. RAKE IN HOOD
- E. 42" MAX. (BUMPER & NOSE)
- F. 6" MAX. (SCOOP/DEFLECTOR)
- G. 4" MIN. AT NOSE AND SIDES - 8" MIN. AT QUARTERS
- H. 19" MAX. (SAME BOTH SIDES)
- I. 112" MAX - 108" MIN.
- J. 29" MAX. - 22" MIN.
- K. 72" MAX. OR NOT PAST BACK OF BLOCK, RIGHT SIDE. LEFT SIDE MAY EXTEND FORWARD TO COVER FOOT BOX IF NECESSARY.
- L. 18" MAX. - 12" MIN. OPENING, BOTH SIDES
- M. WITH 4' LEVEL, MUST HAVE 2" GRADUAL CLEARANCE AT REAR AND NO MORE THAN 5" AT FRONT
- N. 120" MAX. - 106" MIN.
- O. 45" MAX. - 34" MIN.
- P. 3" MAX. HEIGHT AT REAR OF SAIL PANEL, GRADUAL SLOPE FROM ROOF TO THIS POINT
- Q. INTERIOR SLOPE IS 6" MAX. FRONT TO REAR AND FLAT ACROSS. IF FLAT AT FRONT HALF OF INTERIOR YOU HAVE TO USE UP 50% OF YOUR 6" SO FROM BEHIND THE DRIVER TO THE REAR YOU ONLY HAVE 3" OF SLOPE. TOP OF INTERIOR MUST BE FLUSH WITH TOP OF DOORS AND QUARTER PANELS.
- R. 38" MAX. - 28" MIN.
- S. 38" MAX. - 24" MIN.
- T. 66" MAX. - 24" MIN. NO NARROWER THAN RADIATOR
- U. 52" MAX. - 44" MIN.
- V. 56" MAX. - 41" MIN.
- W. TIRES MUST BE THE WIDEST PART OF THE CAR. MUST BE ABLE TO SEE SIDE WALL OF TIRE FROM FRONT, TOP AND REAR.
- X. 66" MAX. - 53" MIN.
- Y. 8" PANEL / 90 DEGREES TO GROUND. MUST BE SOLID, ATTACHED TO THE DECK AND EXTEND TO THE QUARTER PANELS, SECURELY FASTENED.
- Z. ALUMINUM "I" BEAM OR TUBULAR STEEL REAR BUMPERS ALLOWED, MUST BE ROUNDED NERF BARS THAT FOLLOW QUARTER PANEL AND CONNECT BACK TO FRAME ON BOTH SIDES.

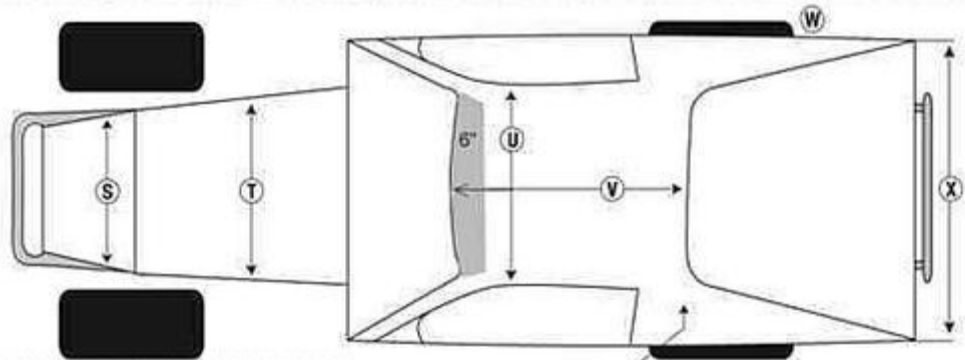

**SAIL PANELS:** Must not be wider than the body and must attach to the quarters in a single stock appearing plane that angles inward to the roof. No fins or lips on sail panels, body, or nose.

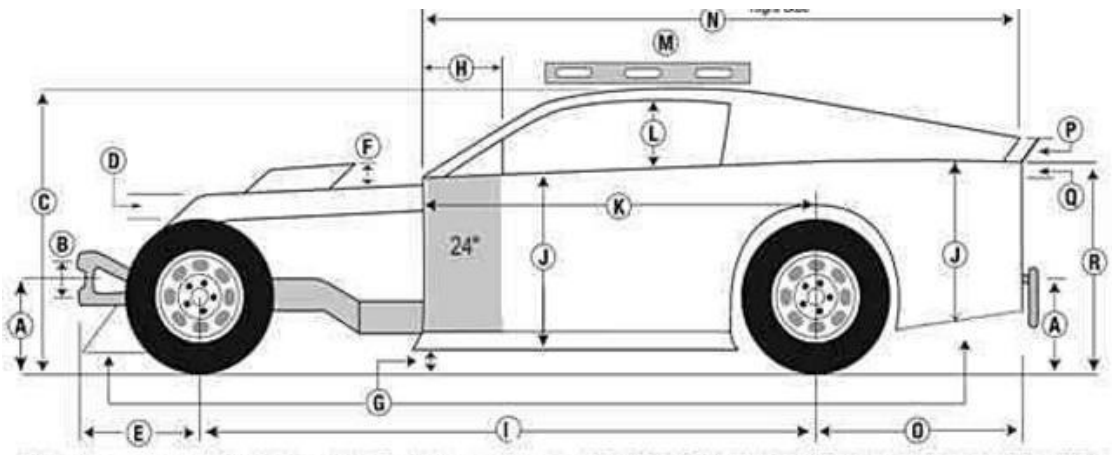

**Shaded area reserved for Series and/or Track Sponsor Decals. MUST DISPLAY DECALS TO BE ELIGIBLE FOR FULL PURSE.**