

# **FP14KCX-ALIGNKIT**

## **FP14KC-X**

### **Runway 'Bolt-On' Alignment Kit**

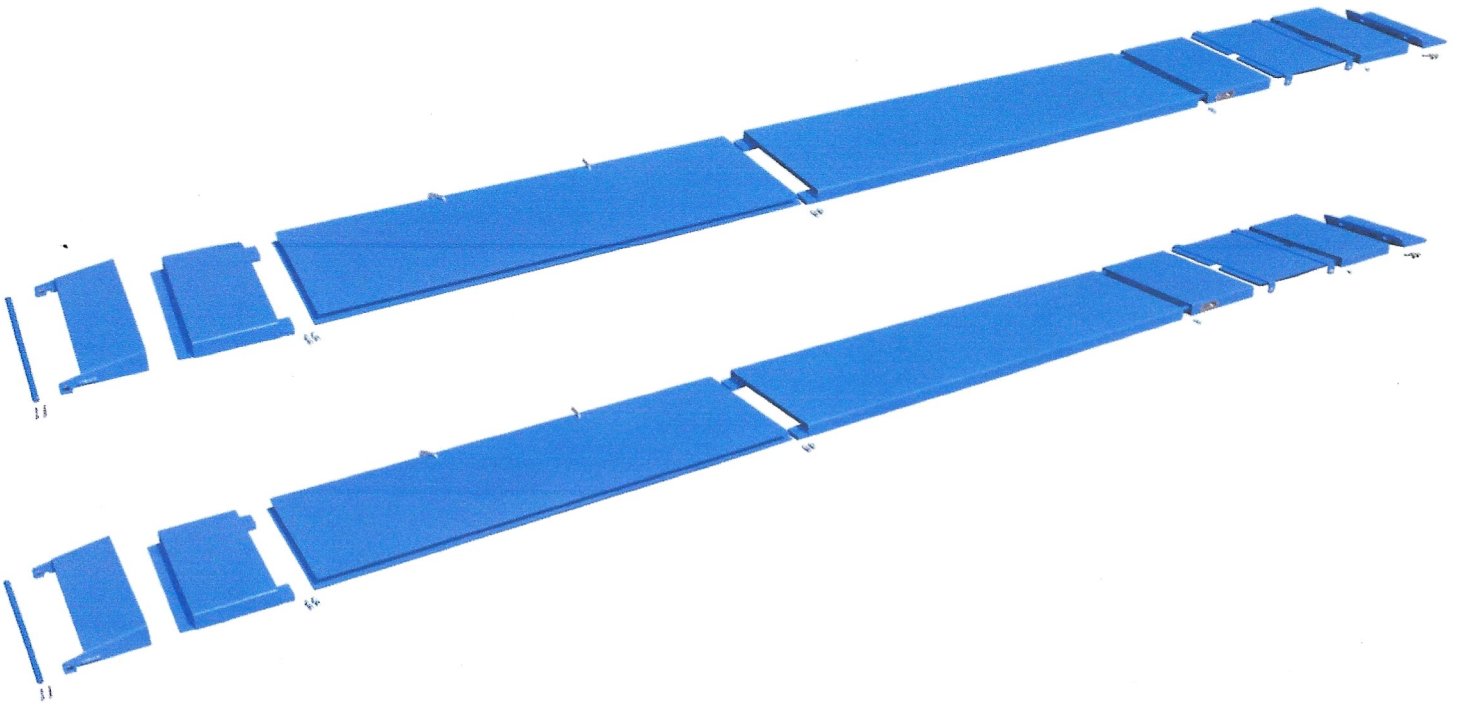

## **Installation Instructions**

### **IMPORTANT!!**

**READ MANUAL THOROUGHLY BEFORE ASSEMBLING, INSTALLING, OPERATING, OR MAINTAINING ALIGNMENT KIT. WHEN DONE WITH INSTALLATION BE SURE TO RETURN DOCUMENTS TO PACKAGE AND GIVE ALL MATERIALS TO LIFT OWNER / OPERATOR.**

# FP14KCX-ALIGNKIT

## FP14KC-X Runway 'Bolt-On' Alignment Kit

### Product Description:

The iDEAL Runway 'Bolt-On' Alignment Kit (FP14KCX-ALIGNKIT) is designed to be applied to the FP14KC-X four post, closed front Service Lift model, allowing to easily convert into a premium Alignment Lift. The FP14KCX-ALIGNKIT will increase the Runway height by 2 inches. Alignment Turntables not included in Kit.

**NOTE:** Mounting holes are already predrilled in Runways for quick Runway Alignment Kit installation.

### Main Kit Components:

1. Alignment Wheel Stop
2. Front Spacer
3. 'Sliding' Turntable Pad
4. 'Movable' Spacer
5. Long Spacer
6. Rear Slip Plate
7. Ramp Support
8. Ramp Extension
9. Ramp Pivot Pin

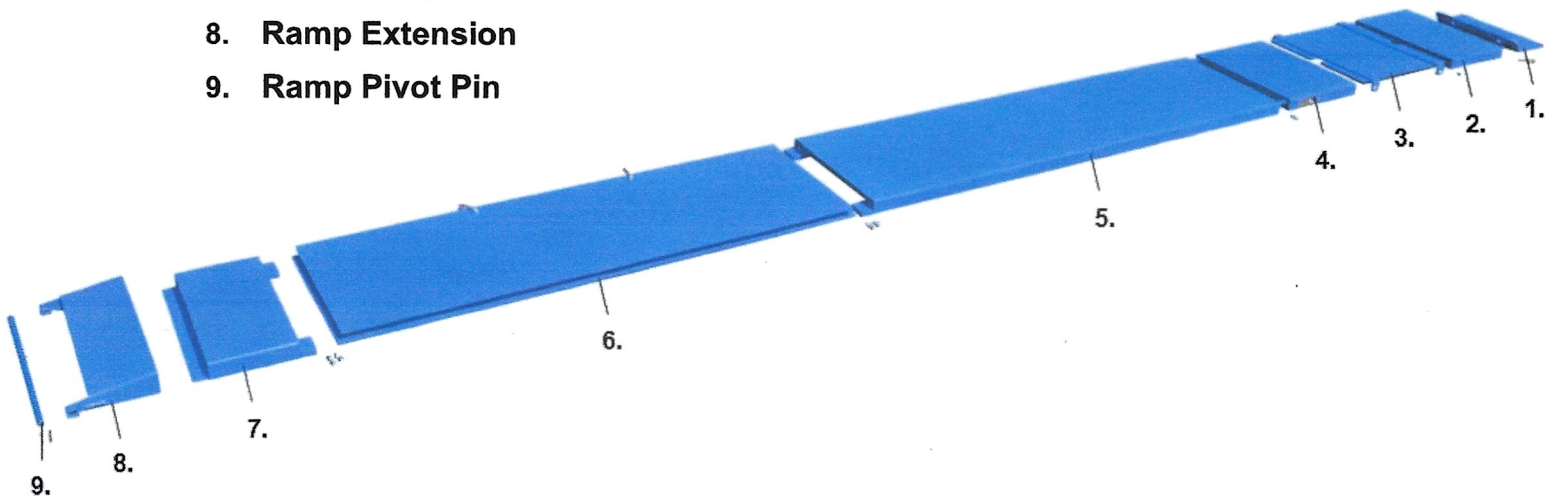

Fig. 1

### Required Tools:

- Fork Lift (Recommended to offload Kit package upon delivery & installation assist)
- Crow Bar
- Metric Sockets or Open Wrench Set (13mm thru 18mm)
- Medium Flat & Philip Screwdrivers
- Needle Nose Pliers
- Safety Glasses
- Gloves

## Installation Instructions:

- 1) Remove bolts that attaches the Wheel Stop & Runway to the Front Crossbeam, if required.
- 2) Position the Front Spacer (#2) on Runway, so the bolt holes align with the Wheel Stop holes and the center hole in Runway - Fig. 2.

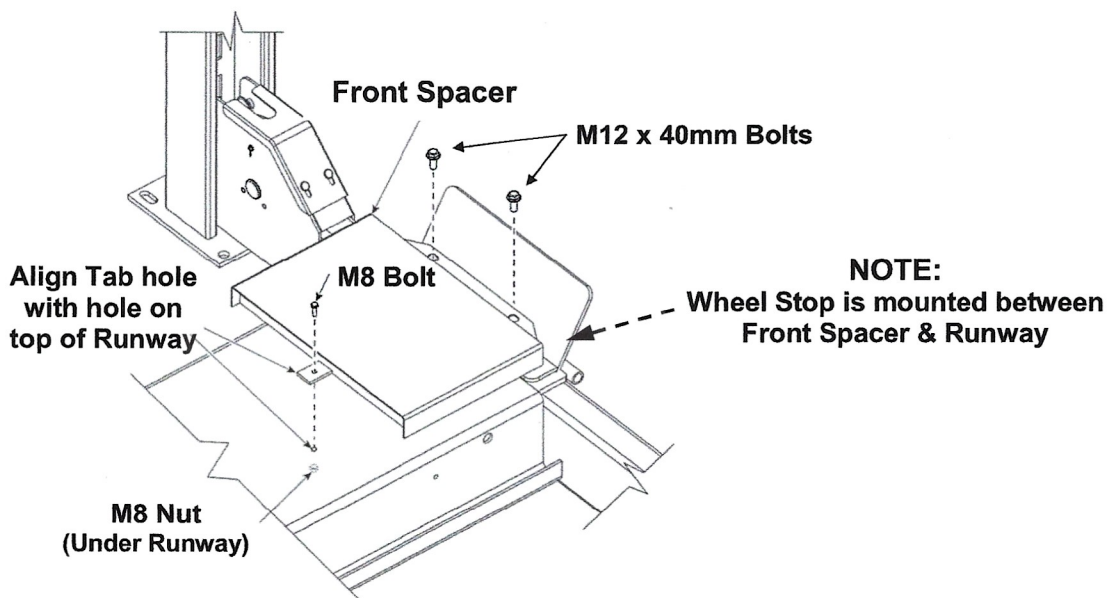

Fig. 2

- 3) Secure back of Front Spacer to Runway using M8 Bolt & Nut, while also securing the front using M12 x 40mm Bolts - Fig. 2. **NOTE:** Alignment Wheel Stop is mounted between Front Spacer & Runway.
- 4) Position the 'sliding' Turntable Pad (#3), so the front edge is positioned against the rear of the Front Spacer - Fig. 3.

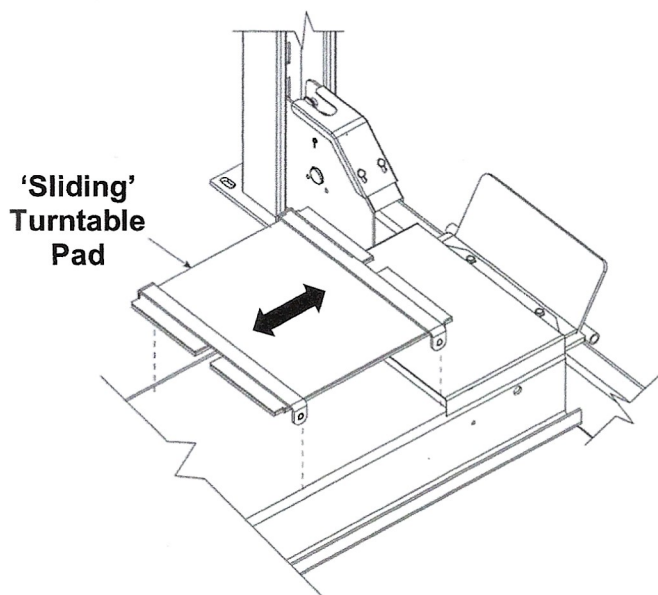

Fig. 3

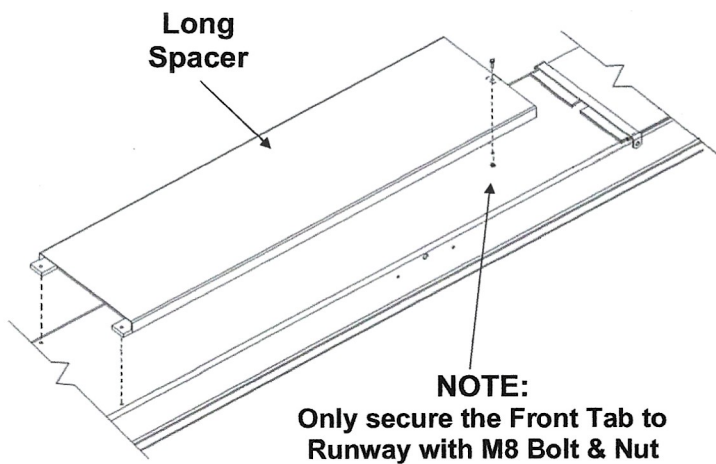

Fig. 4

- 5) Center and square the Long Spacer (#5) on Runway. Align the Tab Holes, bolting only the Front Tab to the Runway, secure using M8 Bolt & Nut - Fig. 4.

- 6) Position Movable Spacer (#4) on Runway behind Turntable Pad. Insert the hooks of Movable Spacer into the holes of the Long Spacer - Fig. 5.
- 7) Carefully, center and square the Rear Wheel Slip Plate (#6) on Runway - Fig 6. **NOTE: Slip Plate Tabs to be positioned above the top of the Long Spacer Tabs. Also Ensure Pins are positioned to the outside of Runway.**
- 8) Remove the Slip Plate L-Pins to gain access to the front holes by angling the front of the Slip Plate. Align the Slip Plate holes to the Tab Holes for the Long Spacer & Runway, secure using M8 Bolts & Nuts noted for - Fig. 6. **NOTE: DO NOT Bolt the back end of Slip Plate at this time.**

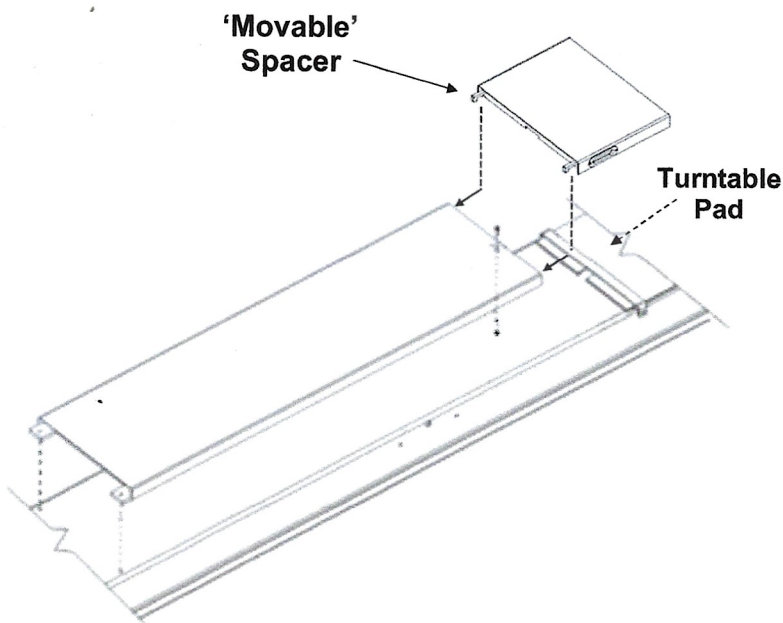

Fig. 5

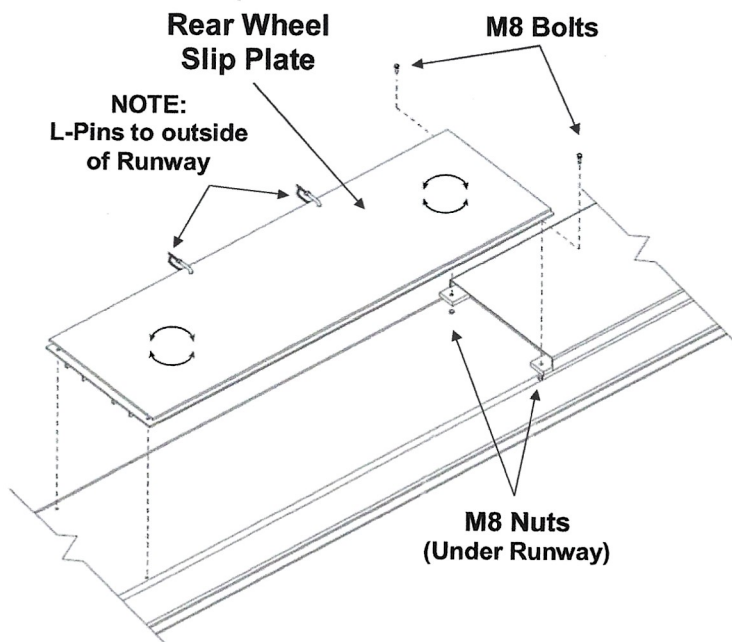

Fig. 6

- 9) Position and slide the Ramp Support (#7) Tabs under the rear of the Slip Plate. Access the rear Slip Plate holes by angling the rear of the Slip Plate. Align the rear Slip Plate holes to the Tab Holes for the Ramp Support & Runway, secure using M8 Bolts & Nuts - Fig. 7.

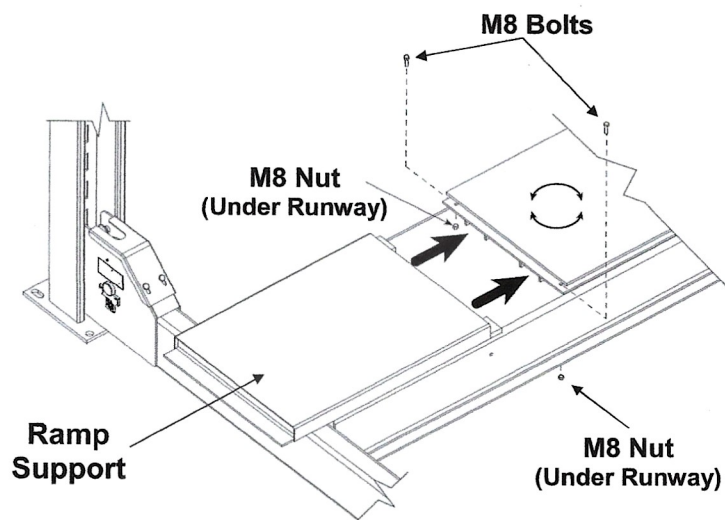

Fig. 7

10) Insert L-Pins back in Slip Plate holes to secure - Fig 6.

11) Remove the Pivot Pin (#9) from Ramp - Fig. 8.

12) Position the Ramp Extension (#8) bracket holes to align to the outside of the pivot tube holes on end of Runway. Insert Pivot Pin to secure Ramp Extension & Spacer to end of Runway. Center & secure Pivot Pin with Cotter Pins at each end - Fig 8.

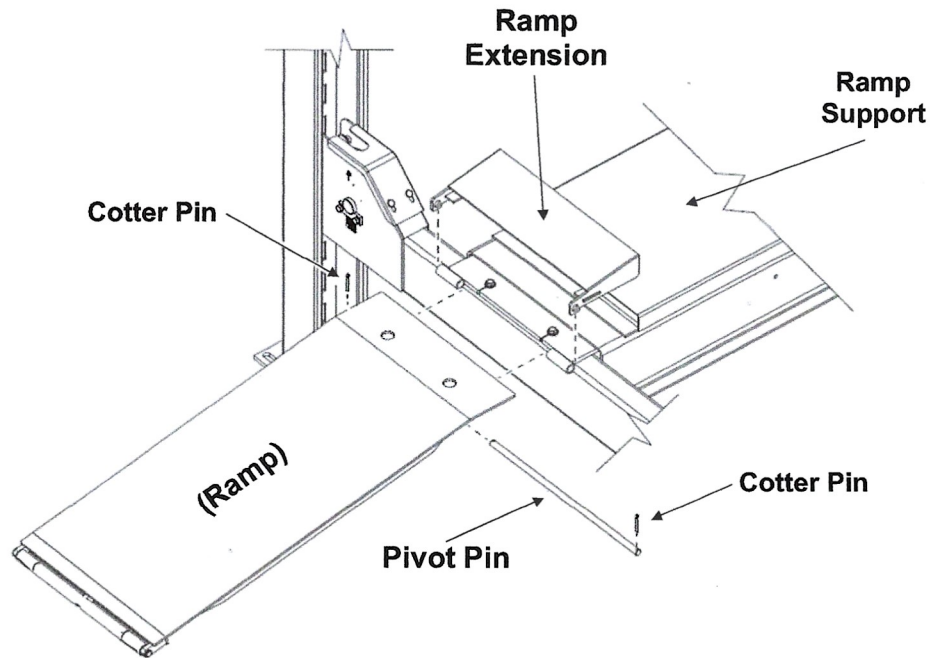
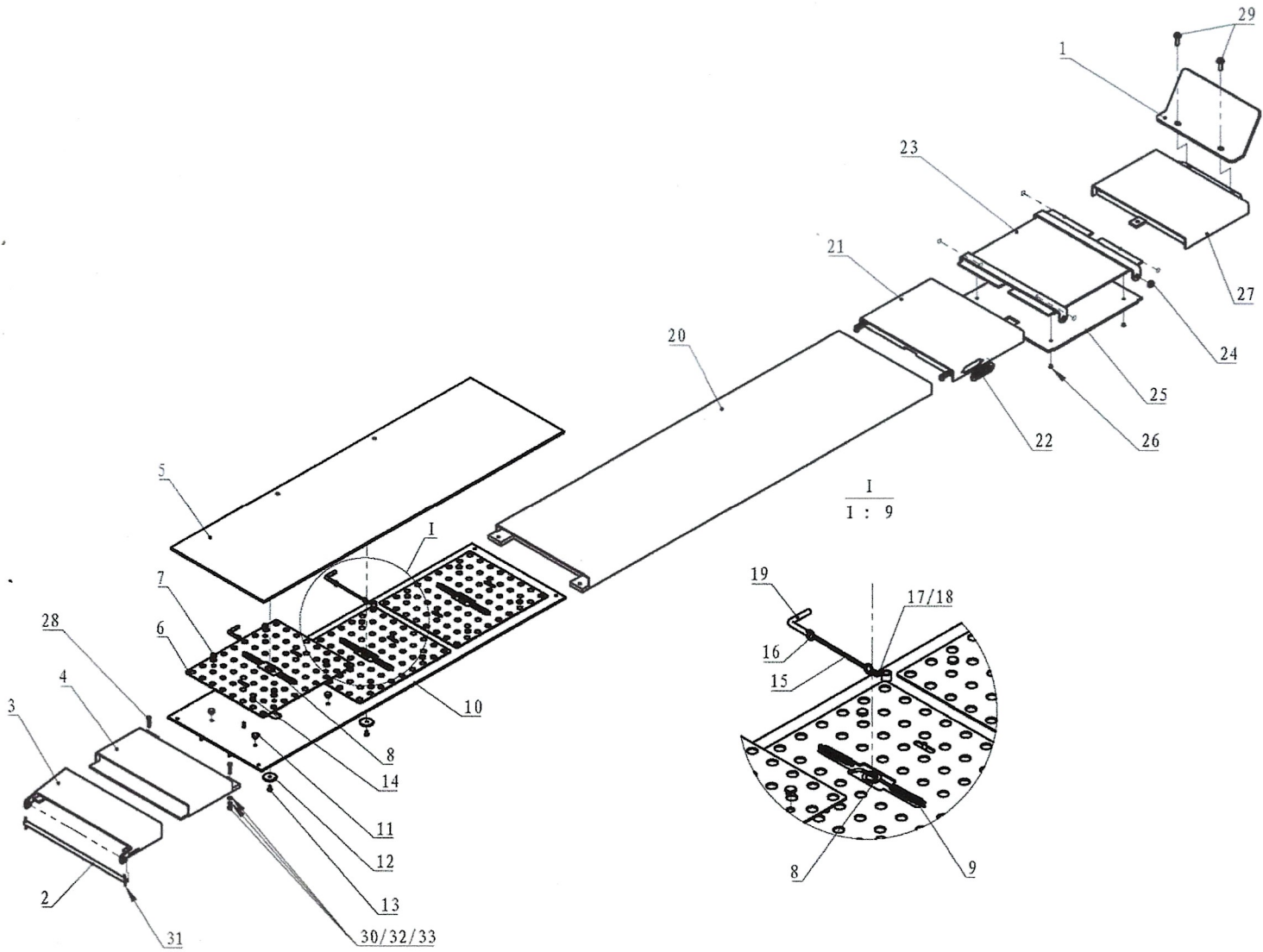

Fig. 8

13) Ensure all 'bolt-on' Alignment Kit components are properly aligned & fully tightened to Runway.

14) Apply the same installation steps for the other Runway.

# Exploded View



## Parts List

ITEM	Tux P/N	M-REF P/N	DESCRIPTION	QTY
1	FP14KCX-ALIGNKIT-001	TT-8861-700-01	'Align' Wheel Stop (9.8" Ht.)	2
2	FP14KCX-ALIGNKIT-002	TT-8861-700-02	'Align' Pivot Pin (Long) 21.7"L	2
3	FP14KCX-ALIGNKIT-003	TT-8861-700-03-HJ	Ramp Extension	2
4	FP14KCX-ALIGNKIT-004	TT-8861-700-05-HJ	Ramp Support	2
5	FP14KCX-ALIGNKIT-005	TT-8861-700-06-HJ	Top Plate	2
6	FP14KCX-ALIGNKIT-006	TT-8861-700-07	Roller Ball Retainer	6
7	FP14KCX-ALIGNKIT-007	TT-8861-700-08	Pin Plug	24
8	FP14KCX-ALIGNKIT-008	TT-8861-700-09	Retainer Ring	6
9	FP14KCX-ALIGNKIT-009	TT-8861-700-10	Spring	12
10	FP14KCX-ALIGNKIT-010	TT-8861-700-11-HJ	Base Plate	2
11	FP14KCX-ALIGNKIT-011	TT-8861-700-12	Nylon Pin	24
12	FP14KCX-ALIGNKIT-012	TT-8861-700-13	Nylon Washer	6
13	FP14KCX-ALIGNKIT-013	GB70.3-2000 M8X16	Screw, M8 x 16mm	6
14	FP14KCX-ALIGNKIT-014	TT-8861-700-14	Roller Balls	396
15	FP14KCX-ALIGNKIT-015	TT-8861-700-15	Link Chain	4
16	FP14KCX-ALIGNKIT-016	TT-8861-700-16	Ring	8
17	FP14KCX-ALIGNKIT-017	TT-8861-700-17	Terminal Ring	4
18	FP14KCX-ALIGNKIT-018	GB818-2000 M6X10	Screw, M6 x 10mm	4
19	FP14KCX-ALIGNKIT-019	TT-8861-700-18	L-Pin	4
20	FP14KCX-ALIGNKIT-020	TT-8861-700-19-HJ	Long Spacer	2
21	FP14KCX-ALIGNKIT-021	TT-8861-700-20-HJ	Movable Spacer	2
22	FP14KCX-ALIGNKIT-022	TT-8861-700-21	Plastic Handle Pocket	4
23	FP14KCX-ALIGNKIT-023	TT-8861-700-25-HJ	Sliding Turntable Pad	2
24	FP14KCX-ALIGNKIT-024	TT-8861-700-26	Nylon Guide Plug	8
25	FP14KCX-ALIGNKIT-025	TT-8861-700-27	Rubber Pad	2
26	FP14KCX-ALIGNKIT-026	GB819-2000 M6X10	Recessed Screw, M6 x 10mm	8
27	FP14KCX-ALIGNKIT-027	TT-8861-700-28-HJ	Front Spacer	2
28	FP14KCX-ALIGNKIT-028	GB5783/2000	Bolt, M8 x 40mm	12
29	FP14KCX-ALIGNKIT-029	GB/T5789-1986	Bolt, M12 x 40mm	4
30	FP14KCX-ALIGNKIT-030	GB6170-2000 M8	Nut, M8	12
31	FP14KCX-ALIGNKIT-031	GB/T91-2000 5X40	Cotter Pin	4
32	FP14KCX-ALIGNKIT-032	GB93-1987 D8	Lock Washer, D8	12
33	FP14KCX-ALIGNKIT-033	GB95-1985 D8	Flat Washer, D8	12