

# **Northern Colorado Riding Club**

Pattern Book #1

June 2nd 2019

# Hunt Seat Equitation

Novice Rider

Green Horse

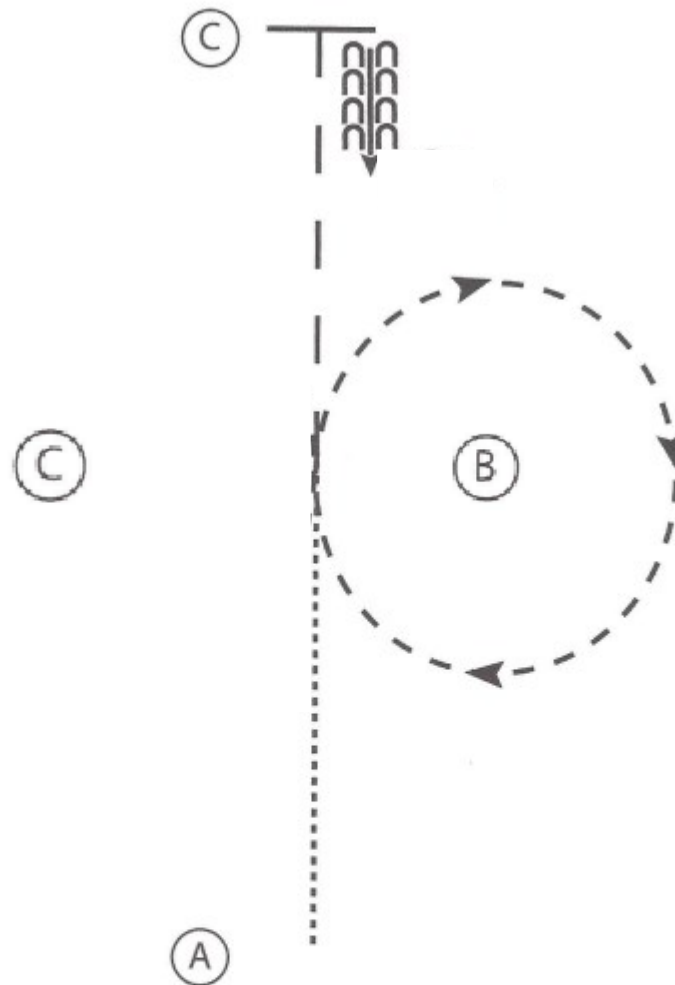

1. Walk from A to B
2. Between B and C, pick up sitting trot and circle B
3. At B, pick up posting trot, left diagonal to D
4. At D, stop and back 4 steps

Walk	.....
Trot	-----
Extended Trot	-----
Canter	—————
Leg Yield	
Lead Change	↘
Back	←←←←
Marker	Ⓚ
Sidepass	←-----→

# Hunt Seat Equitation

All Ages

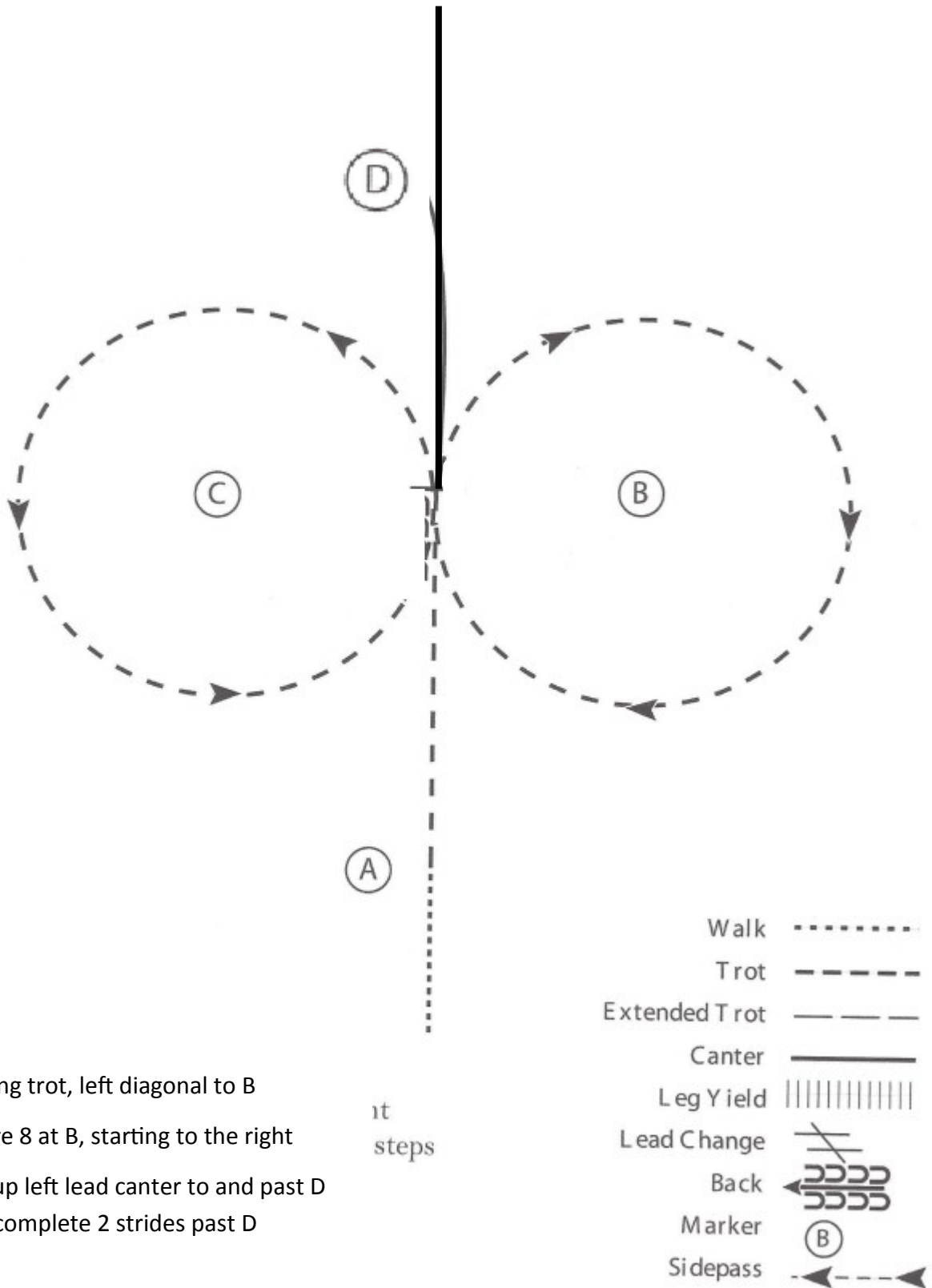

1. Walk to A
2. At A, Posting trot, left diagonal to B
3. Begin figure 8 at B, starting to the right
4. At B, pick up left lead canter to and past D  
Pattern is complete 2 strides past D

# Showmanship

Novice Rider

Green Horse

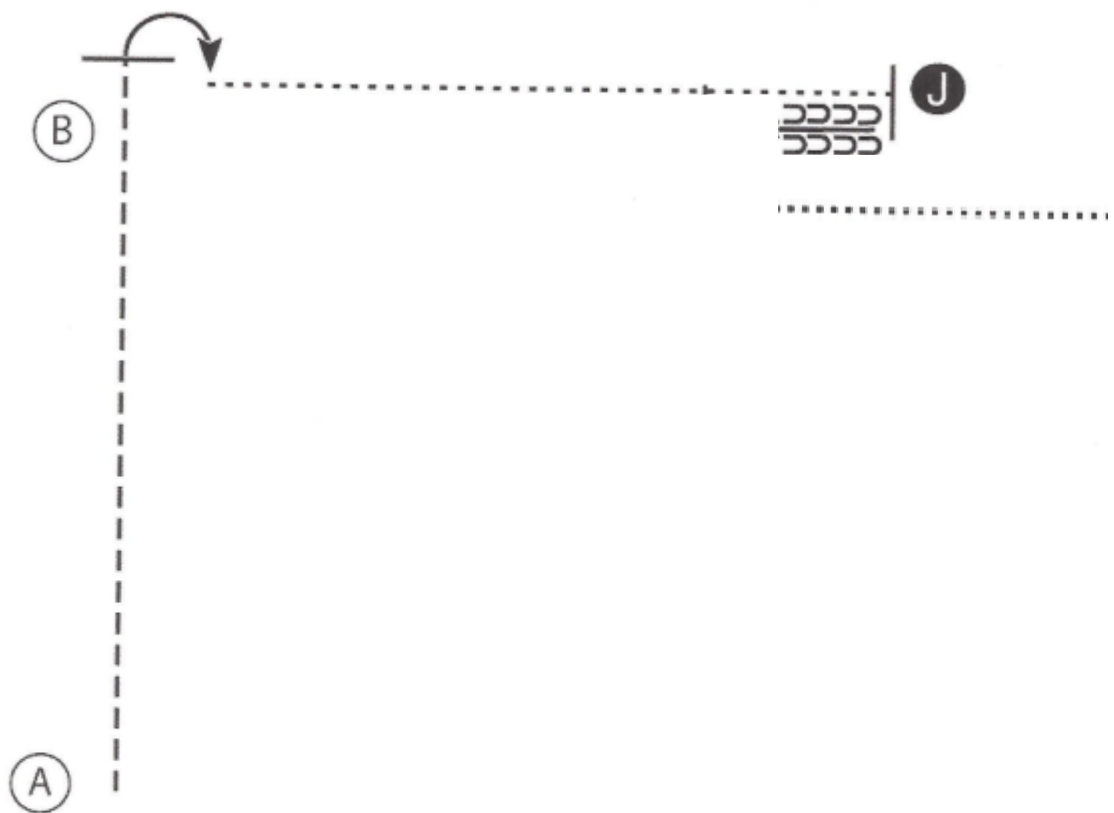

1. Begin at A. Trot from A, past B.
2. Stop and perform a 90 degree turn.
3. Walk to the Judge, stop and set up for inspection.
4. When dismissed back one horse length and walk past judge.

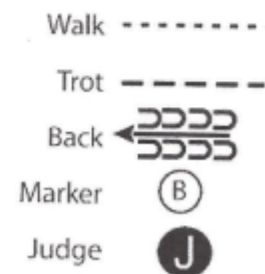

# Showmanship

All Ages

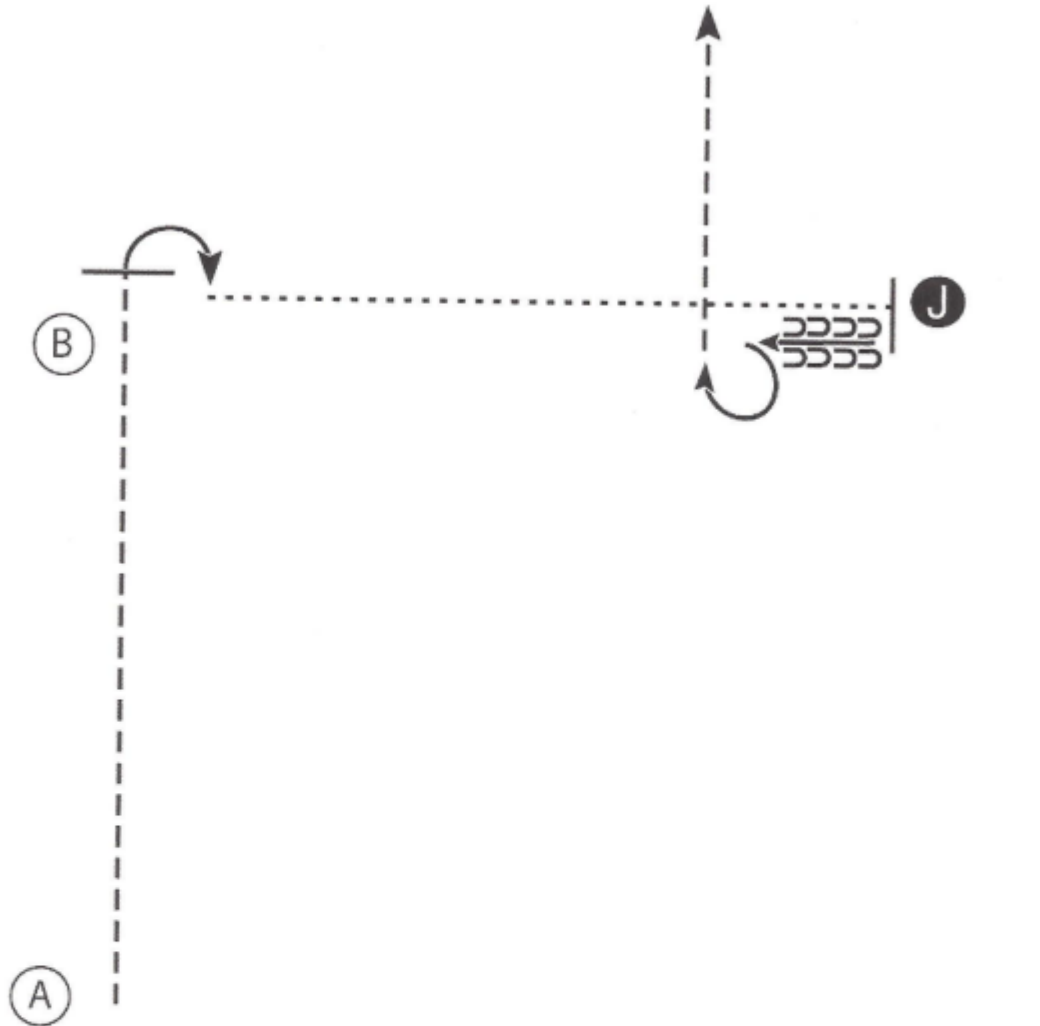

1. Begin at A. Trot from A past B
2. Stop and perform a 90 degree turn
3. Walk to the Judge, stop and set up for inspection
4. When dismissed back one horse length and perform a 270 degree turn
5. Trot to the line-up

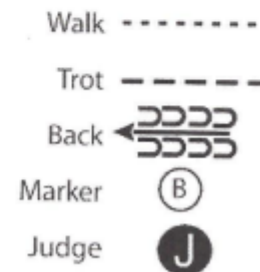

# Western Horsemanship

Novice Rider

Green Horse

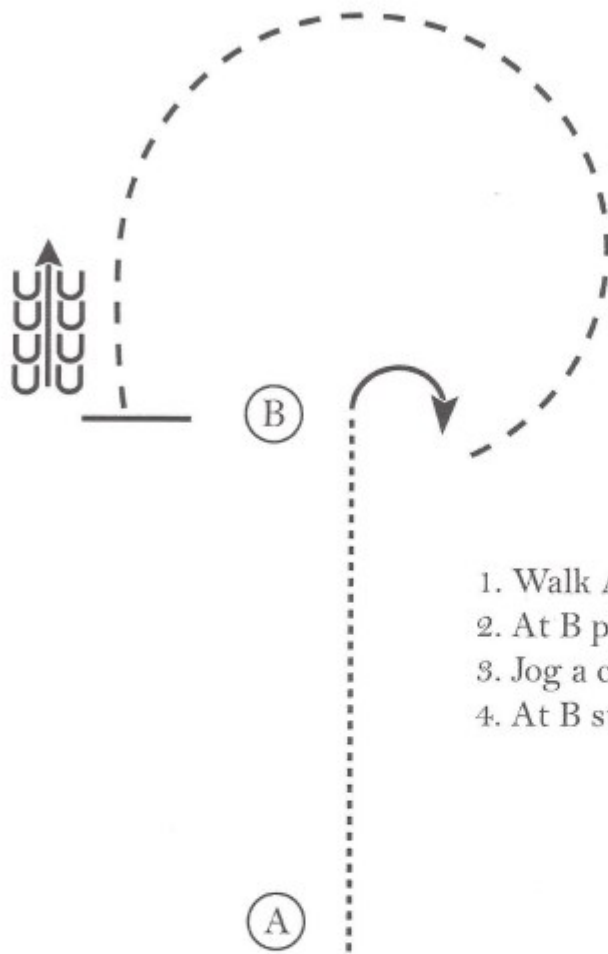

1. Walk A to B
2. At B perform a 90 degree turn to the right
3. Jog a circle around B
4. At B stop and back 4 steps

Walk	.....
Jog	-----
Extended Jog	- - - - -
Lope	—————
Leg Yield	
Lead Change	— / —
Back	←←←←←
Marker	ⓑ
Sidepass	← - - - - →

# Western Horsemanship

All Ages

1. Walk to A.
2. At A stop and back 3 steps.
3. Jog A to B.
4. Stop at B and perform a 360 degree turn to the right.
5. Jog a circle to the right
6. At B lope on the left lead, lope a circle to the left
7. Continue the lope
8. Stop

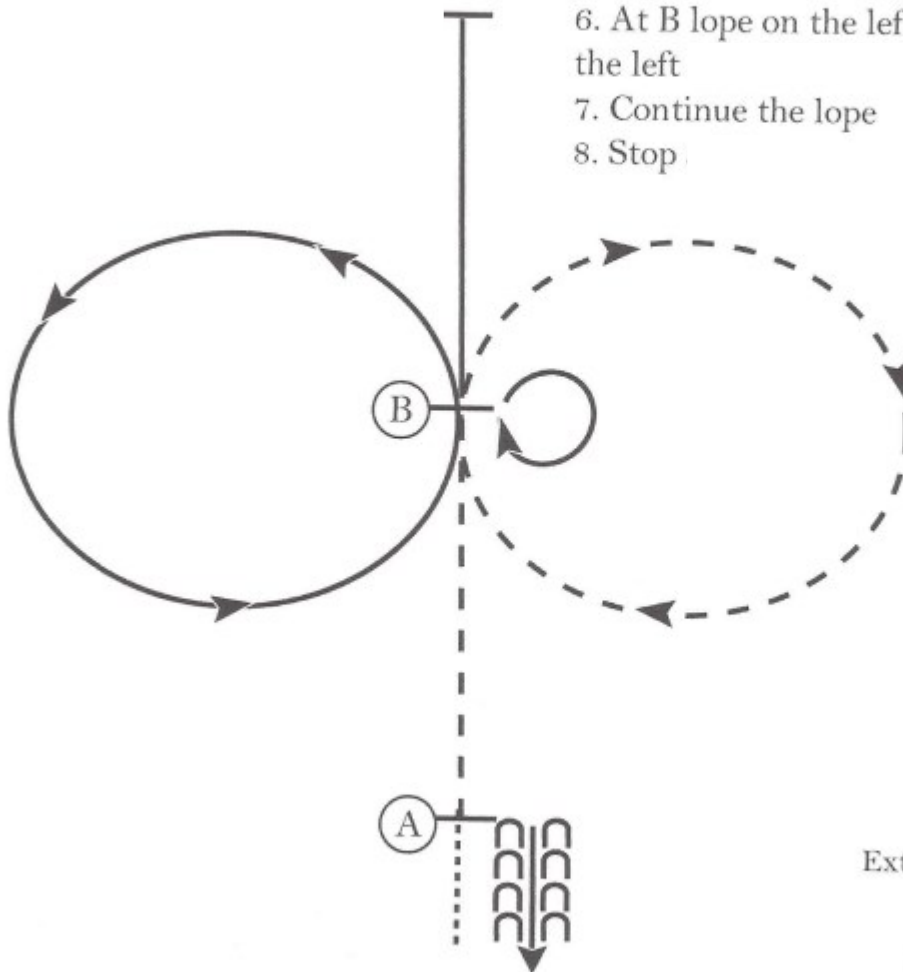

Walk	.....
Jog	-----
Extended Jog	—————
Lope	—————
Leg Yield	
Lead Change	—/—
Back	← C C C C
Marker	⊙ B
Sidepass	← - - - →

# Trail

Novice Rider

Green Horse

Leadline (gate optional)

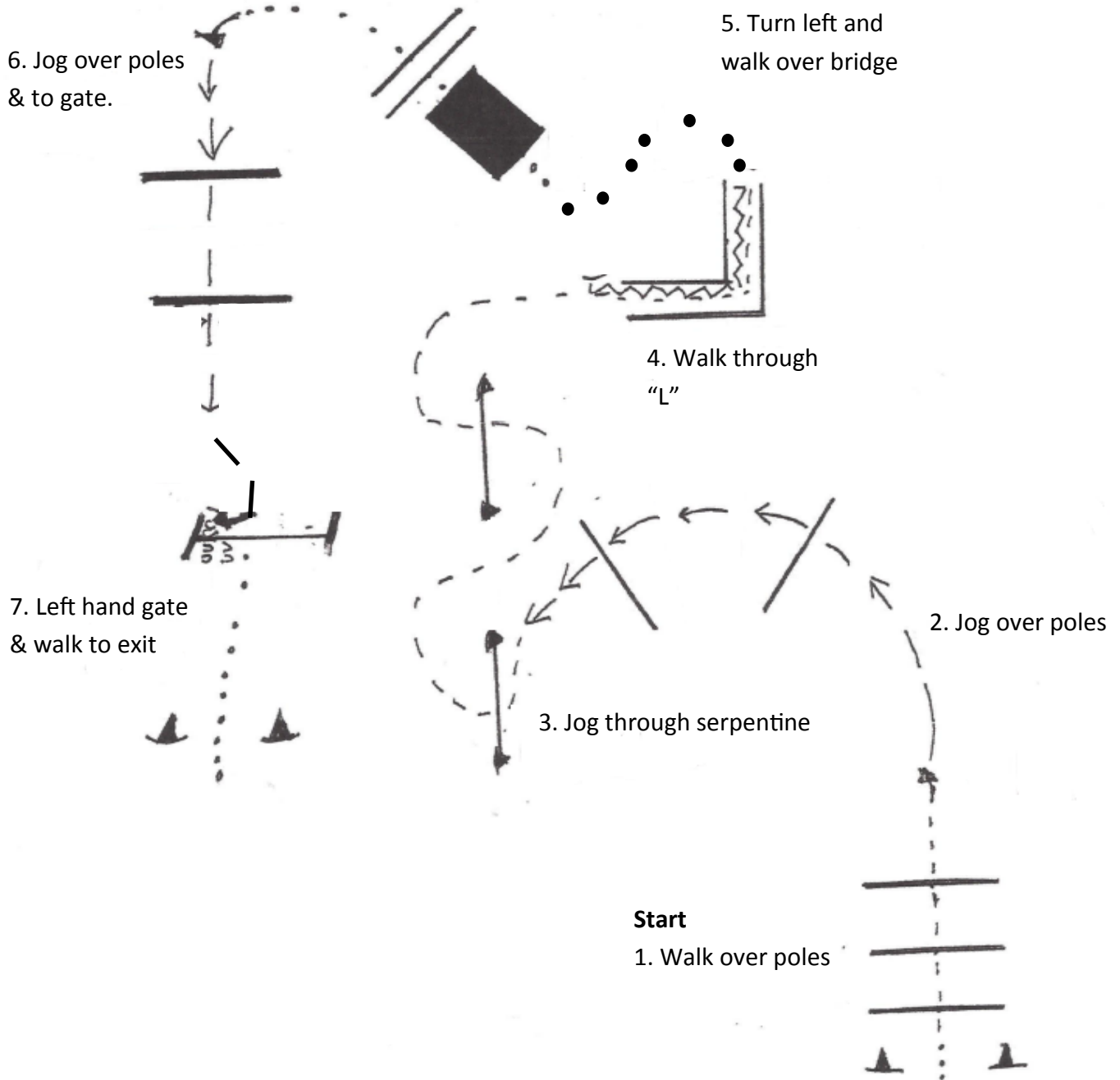



# Trail

All Ages

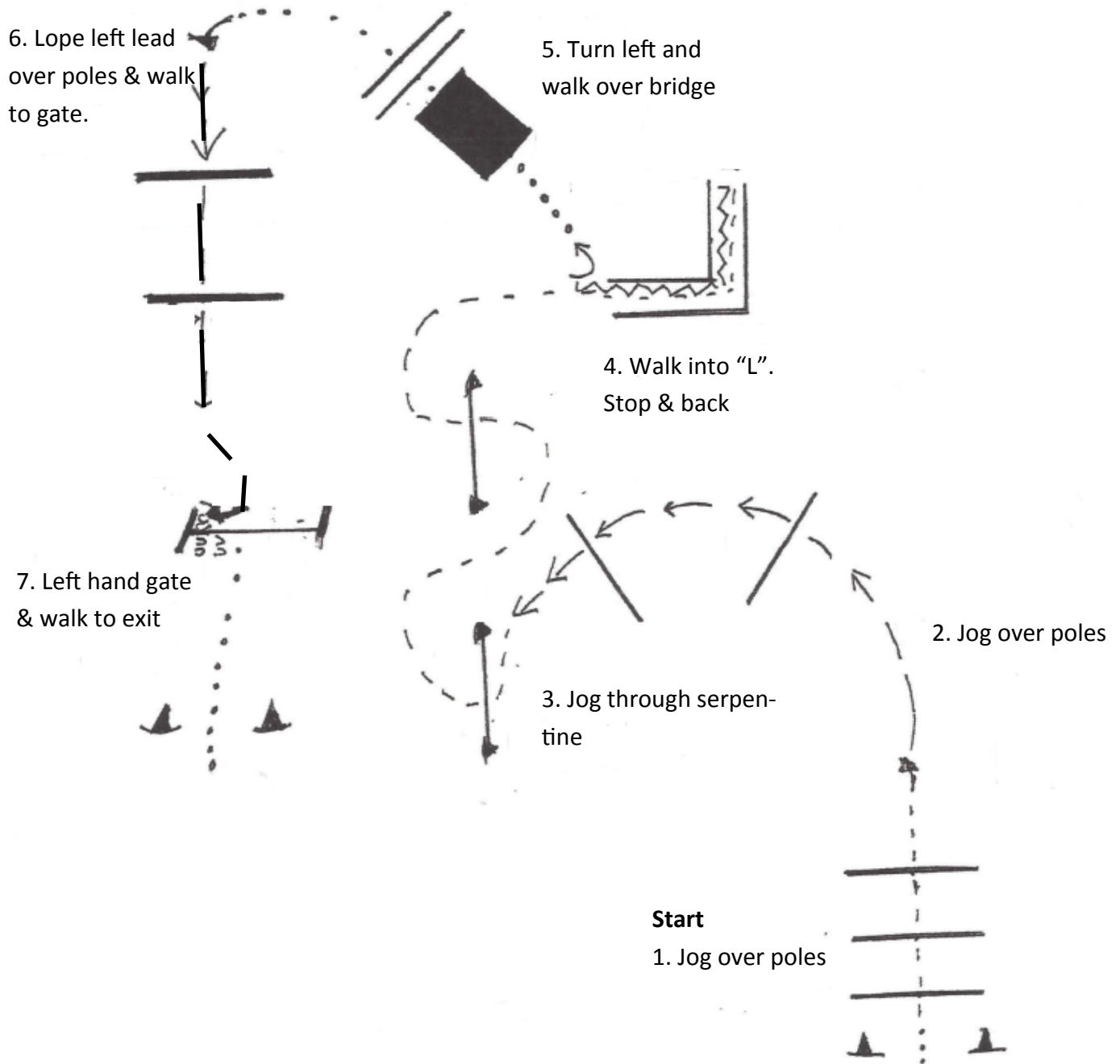

# Ranch Trail

All Ages

3. Break to walk & walk over poles and bridge

2. Pick up jog & jog over poles

**Start**

1. Walk to gate.  
Left handed gate.

4. Walk through the "L", then back the "L"

5. Pick up right lead, lope poles

6. Walk over poles

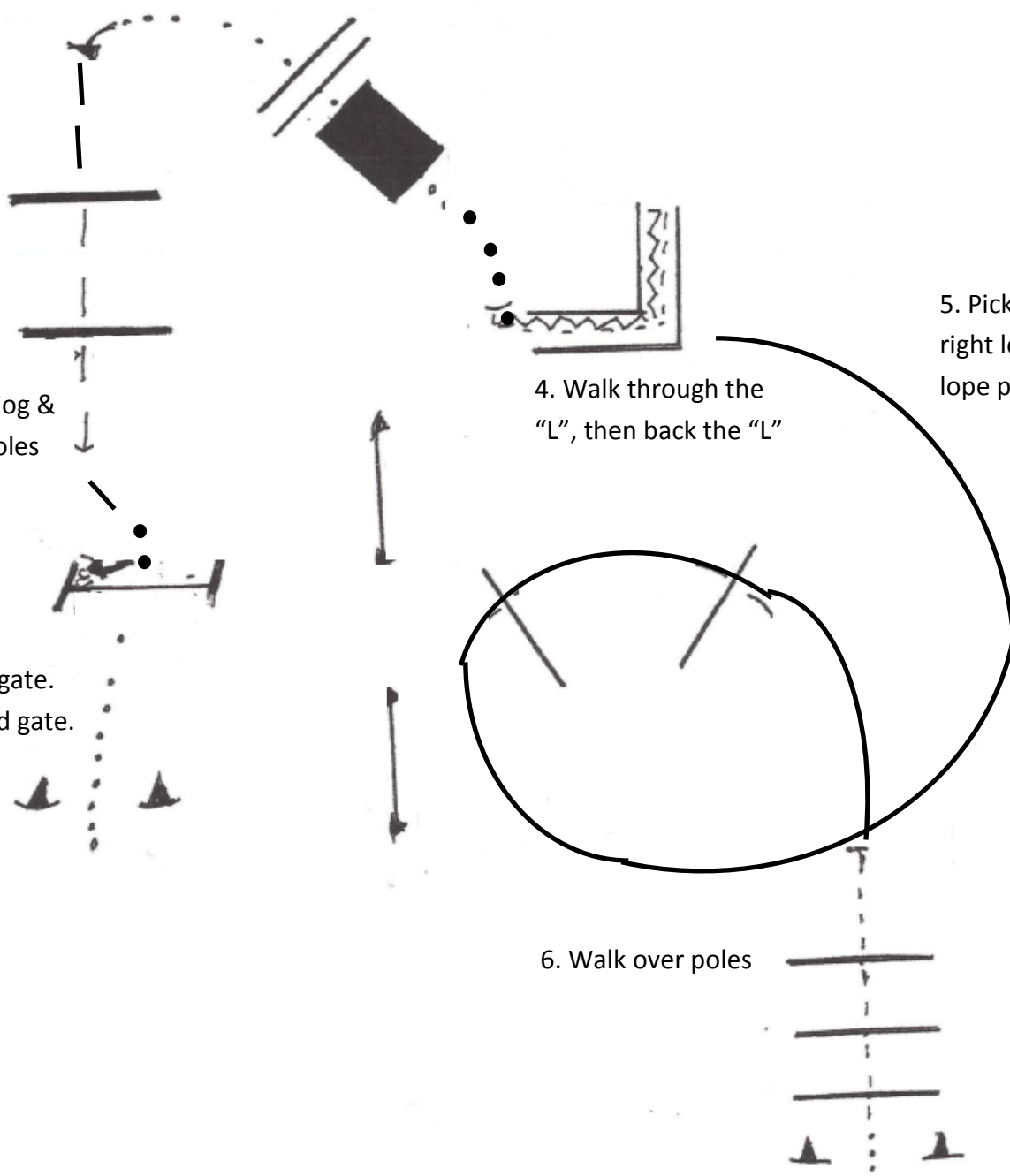

# Ranch Riding

All Ages

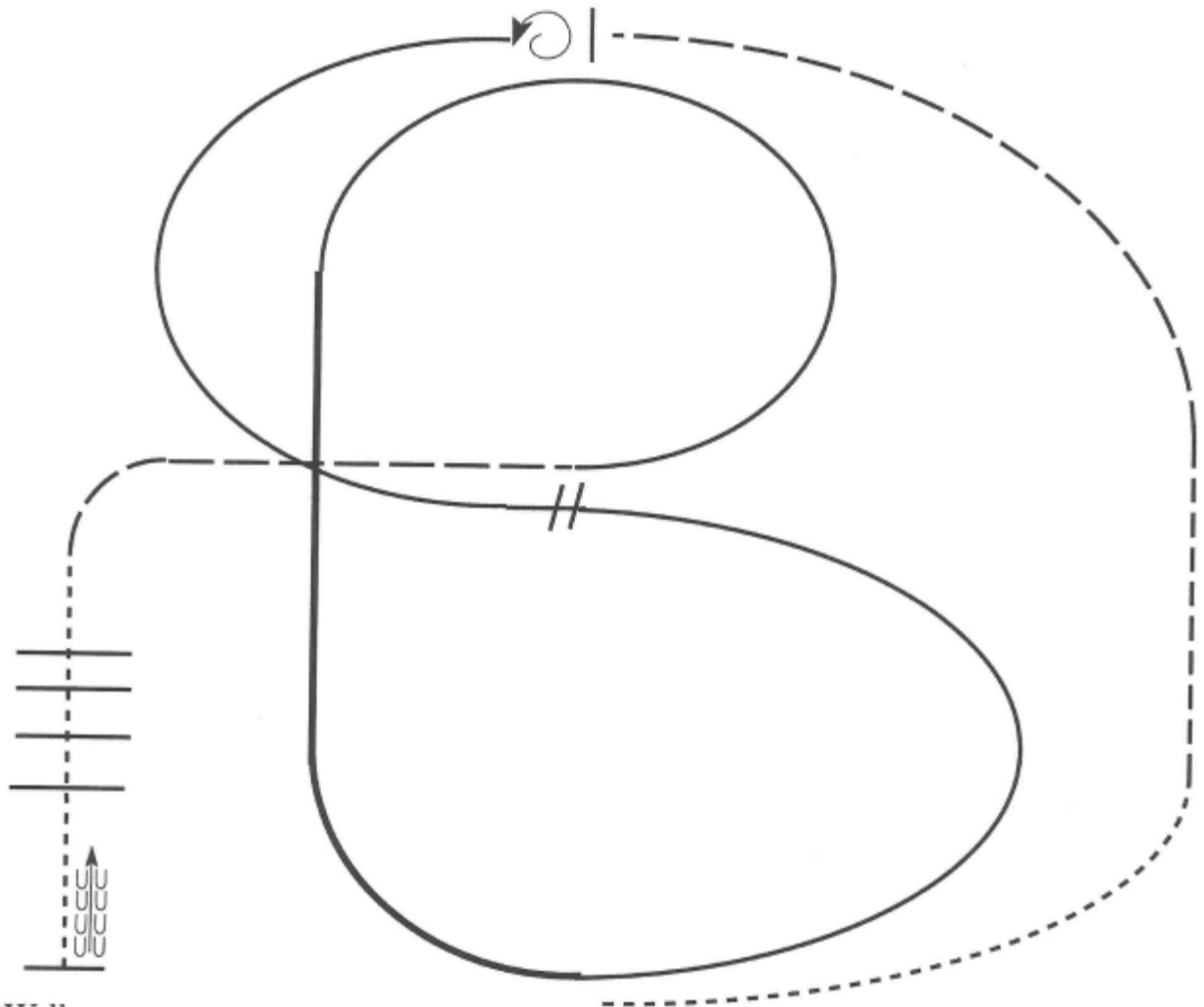

1. Walk
2. Trot
3. Extend the trot, at the top of the arena, stop
4. 360 degree turn to the left
5. Left lead 1/2 circle, lope to the center
6. Change leads (simple or flying)
7. Right lead 1/2 circle
8. Extended lope up the long side of arena (right lead)
9. Collect back to a lope around the top of the arena and back to center
10. Break down to an extended trot
11. Walk over poles.
12. Stop and back

Walk	-----
Jog	- - - - -
Extended Jog	— — — — —
Lope	—————
Lead Change	
Back	
Marker	(B)

# Reining

All Ages

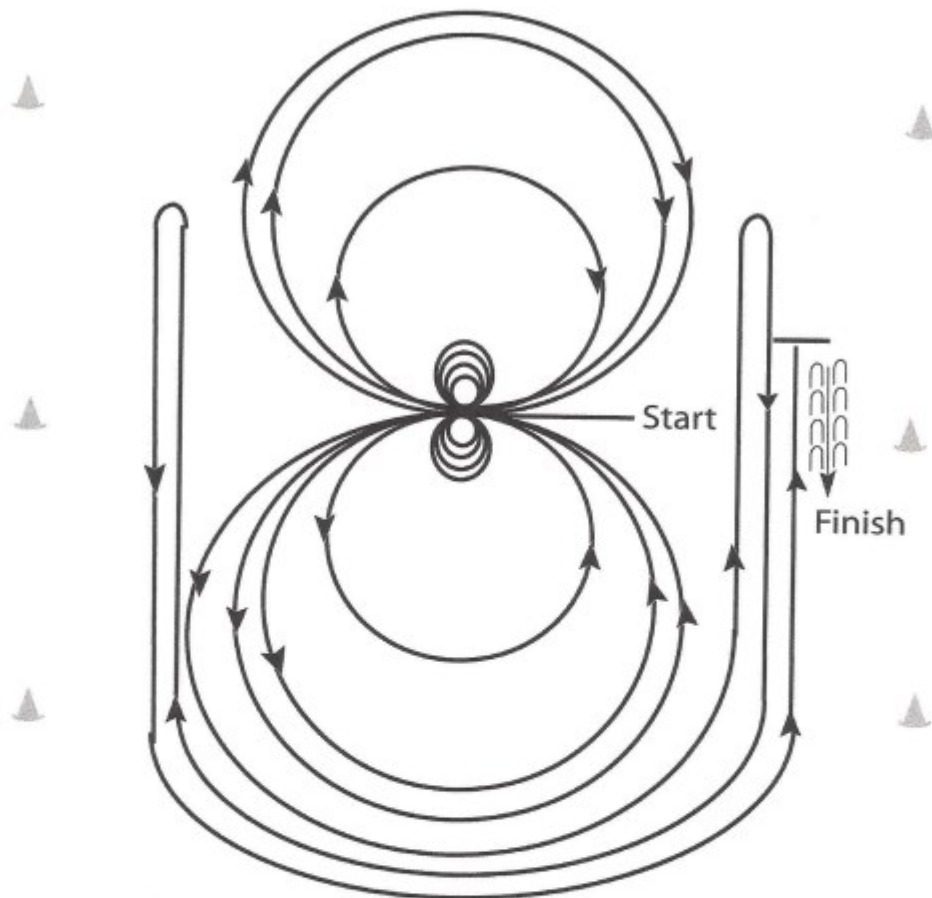

Horse must walk or stop prior to starting pattern. Beginning at the center of the arena facing the left wall or fence.

1. Complete four spins to the right.
2. Complete four spins to the left. Hesitate.
3. Beginning on the left lead, complete three circles to the left: the first two circles large and fast; the third circle small and slow. Change leads at the center of the arena.
4. Complete three circles to the right: the first two circles large and fast; the third circle small and slow. Change leads at the center of the arena.
5. Begin a large, fast circle to the left but do not close this circle. Run up the right side of the arena past the center marker and do a right rollback at least twenty feet (6.09m) from the wall or fence – no hesitation.
6. Continue back around previous circle but do not close this circle. Run up the left side of the arena past the center marker and do a left rollback at least twenty feet (6.09m) from the wall or fence – no hesitation.
7. Continue back around previous circle but do not close this circle. Run up the right side of the arena past the center marker and do a sliding stop at least twenty feet (6.09m) from the wall or fence. Back up at least ten feet (3m). Hesitate to demonstrate the completion of the pattern.