

PRAGA NORTH AMERICA | 2015 PRAGA PRODUCTS

Praga NORTH AMERICA



WWW.PRAGANORTHAMERICA.COM



The best materials make the best products

Based in Italy, the IPK engineering team designs their product line using the highest quality materials. The team is constantly developing and innovating to make their product more effective and efficient, along with the help of the official race teams.

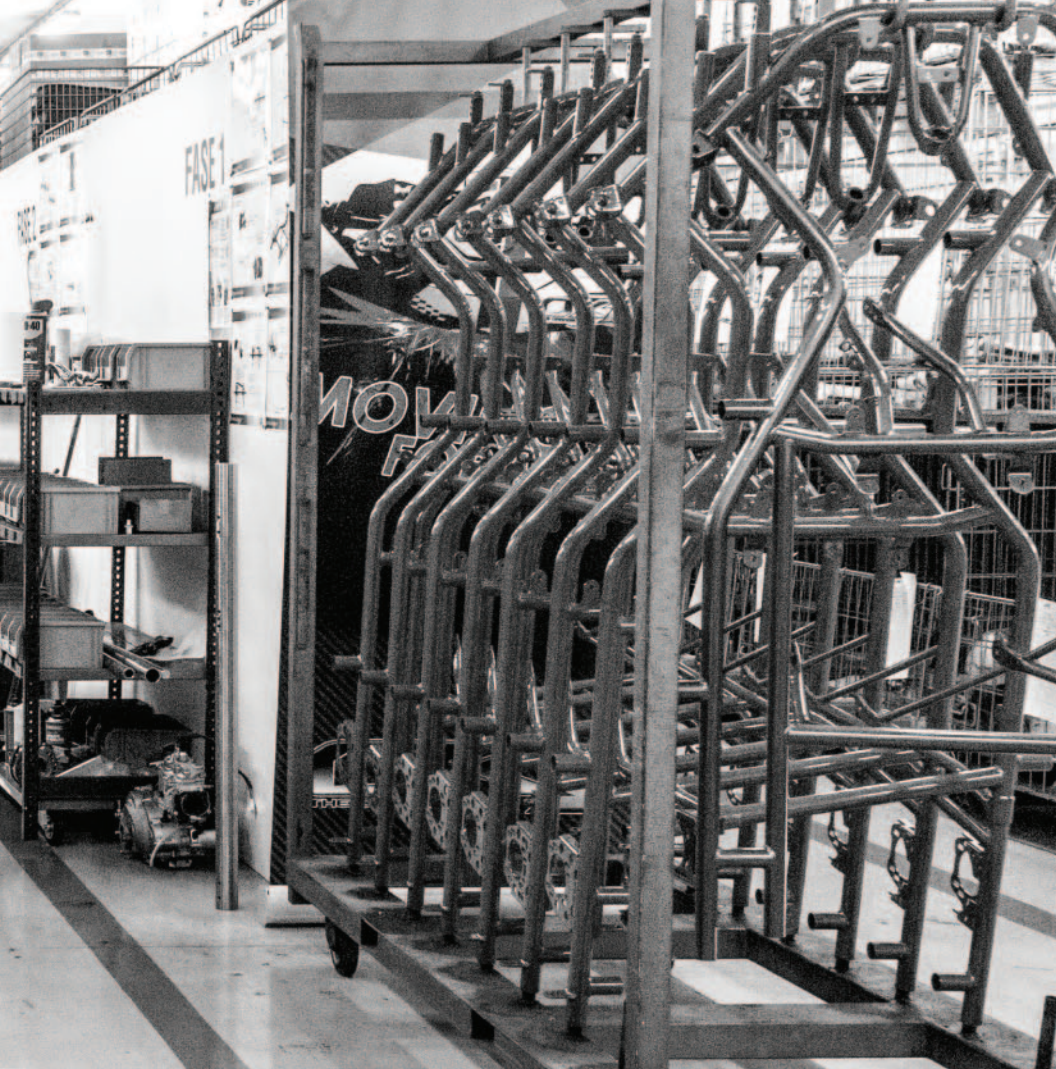

Table of Contents

4 <i>New for 2015</i>	14 <i>Praga Dark Dark 28</i>
6 <i>Praga Dragon EVO</i>	16 <i>Praga Baby</i>
8 <i>Praga Tacho</i>	18 <i>Comp Chart</i>
10 <i>Praga Invictus</i>	20 <i>Chassis Chart</i>
12 <i>Praga Piccolo</i>	22 <i>Team Praga</i>



Praga

All-New for 2015

Praga has 2 new chassis homologations, updated standard equipment, and new optionals for the 2015 season. The new Dragon EVO is composed of all 30mm tubes, and the Praga Invictus is a 32mm chassis perfect for low grip situations.



2015 Standard Equipment

Our redesigned brake system is lighter, with better ventilation. The new brakes come standard along with both the updated 5-hole spindle for finer Ackermann adjustments and a new sticker graphics kit.

The Optional Features

Praga also has several new optional features available for 2015, including a straight front steel stabilizer bar for use in high grip situations and a universal adjustable pedal system which can be mounted to any chassis model.

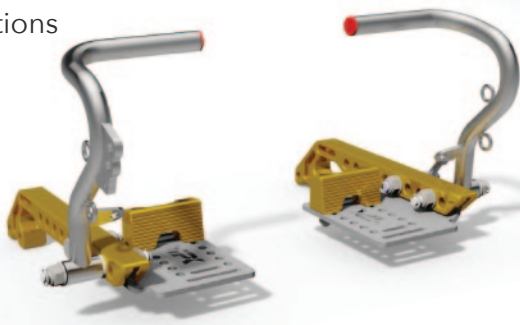

PRAGA NORTH AMERICA

The All-New Products for 2015

NEW MODEL
2015



About the Praga Dragon EVO

With a new 2015 homologation, the Dragon EVO is composed of all 30mm tubes and incorporates a design perfected over years of testing and evaluation.

The new chassis design is complimented by 5-hole spindles for greater Ackermann control, and a more efficient brake system. The Dragon EVO is available in TAG, Shifter, DD2, and Minimax models.



PRAGA DRAGON EVO

The New 30mm Race Line Chassis



30mm
Tubular Frame



25mm MOD. R
Spindle



50X2X1030mm
Axle

The Dragon EVO has been perfected over years of testing and evaluation.

NEW MODEL
2015



CIK-FIA
HOMOLOGATION
87/CH/20

About the Praga Tacho

The Tacho chassis is a tried-and-true chassis, having won races around the world including the 2012 World Championship. The frame design is a 30mm tubular frame with a 32mm center crossbar. It is comfortable to drive and great for drivers looking for lateral grip on the track. The Tacho is available in TAG and Shifter models.



PRAGA TACHO

The World Championship Chassis



30-32mm
Tubular Frame



25mm MOD. R
Spindle



50X2X1030mm
Axle



The Tacho is the tried-and-true chassis of the Praga family.



CIK-FIA
HOMOLOGATION
66/CH/15

About the Praga Invictus

The new Invictus chassis completes the race line, with an all 32mm frame, except for a 30mm front nose bar. This offers a solution for low grip situations or bigger drivers.

The Invictus is available in TAG and Shifter models.

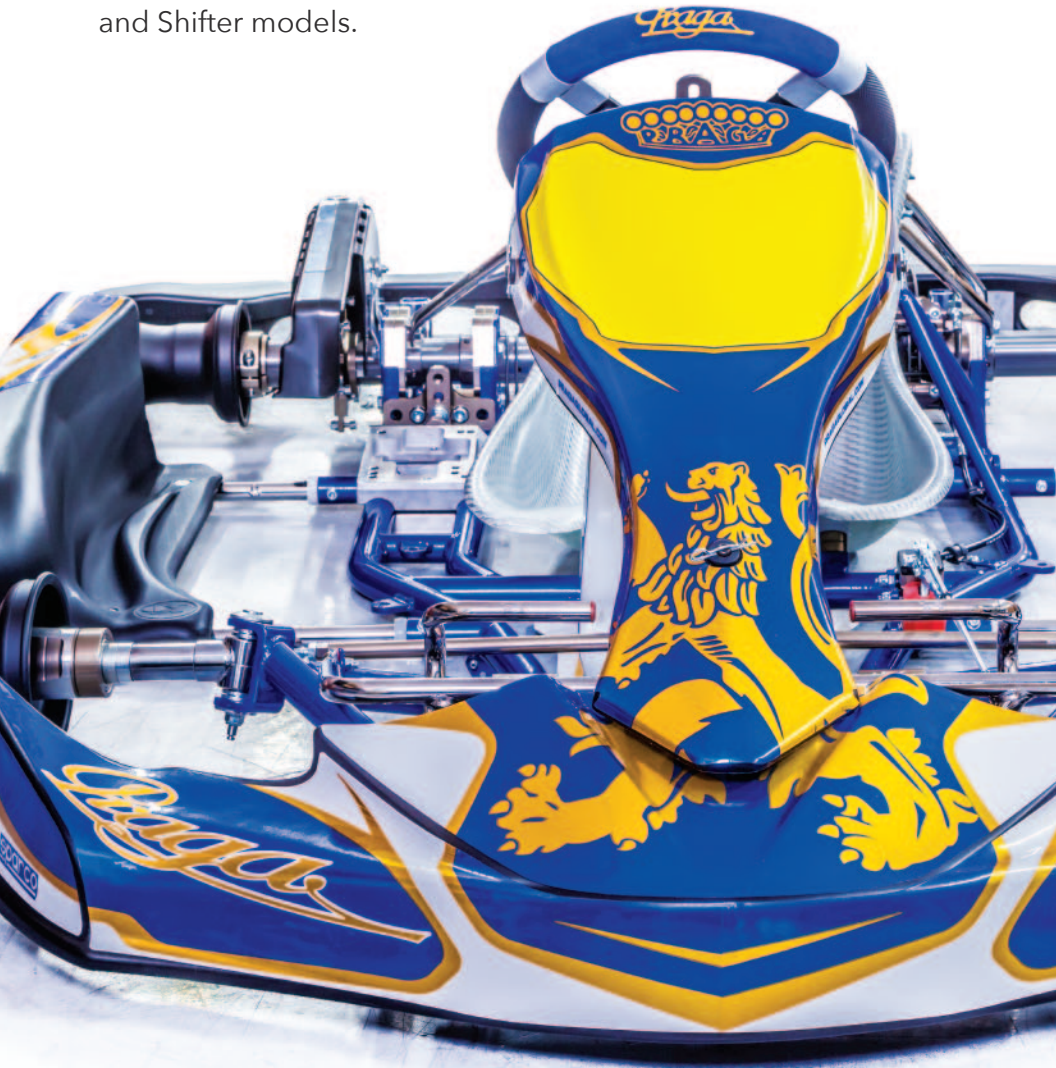

PRAGA INVICTUS

The New 32mm Race Line Chassis



30-32mm
Tubular Frame



25mm MOD. R
Spindle



50X2X1030mm
Axle



*The Invictus is a new 32mm
frame designed for low
grip tracks.*

NEW MODEL
2015

CIK-FIA
HOMOLOGATION
88/CH/20

About the Praga Piccolo

The Piccolo is the top chassis for young drivers worldwide. With a 28mm frame, and the same floating brake used on the shifter model, the Piccolo is designed to ensure the maximum efficiency and safety. Available in variable wheelbases.



PRAGA PICCOLO

The Premier Cadet Chassis



28mm
Tubular Frame



3.5 Liters
Tank

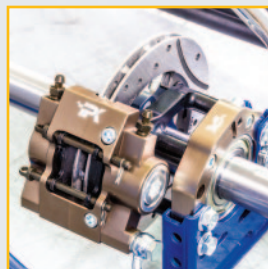

MKB-V1 System
Brakes



*The Piccolo is the top
chassis for young drivers
worldwide.*

CIK-FIA
HOMOLOGATION
22/CH/14

About the Praga Dark

Developed to the same standards as our top line chassis, the 30mm Dark utilizes basic components to keep the price point low. For those drivers working on a budget or just starting out, this is the perfect entry-level kart. Also available is the Dark 28, the 28mm counterpart developed specifically for 4-cycle racing.



PRAGA DARK | DARK 28

The Entry Level Chassis



Aluminum
Wheels



30mm or 28mm
Tubular Frame

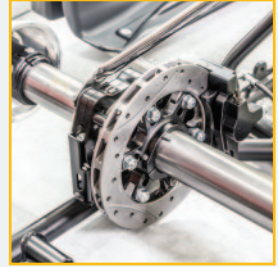

Hydraulic System
Brakes

The Praga Dark chassis is the solution to karting's high costs.



About the Praga Baby

The kart for young drivers who are just beginning their racing career. The Praga Baby is optimally designed for ease of use and maintenance, with the highest safety and efficiency standards. The kart has a 28mm frame, mechanical brake system, and adjustable seat and pedals.



PRAGA BABY

The Kid Kart Chassis



28mm
Tubular Frame



Honda GX35
Engine



Adjustable Footrest
Pedals

The Praga Baby is optimally designed for ease of use and maintenance.



	BABY	DARK	PICCOLO
FRAME	28mm High-Strength Steel Frame	30mm High-Strength Steel Frame	28mm High-Strength Steel Frame
BODYWORK	MK14 - Puffo Top Line Model with Rear Plastic Bumper	FP7 - Stilo Top Line Model with Rear Plastic Bumper	MK14 - Top Line Model With CIK-FIA Homologated Supports
BRAKES	Mechanical Brake System with 140.5mm Rear Disc	Hydraulic Brakes with Oil Recovery Tank, Iron Cast Brake Disc	MKB-V1 Brakes with Oil Recovery Tank, Floating 149mm Ventilated Disc
STEERING	Top Line Steering System with 300mm Wheel	Top Line Steering System with 300mm Wheel	Top Line Steering System with 330mm "Le Mans" Steering Wheel
TANK	0.63 Litre	8.5 Litres	3.5 Litres
WHEELS	Aluminum Alloy 5" 115mm (Front) 140mm (Rear)	Aluminum Alloy 5" 130mm (Front) 210mm (Rear)	Magnesium 5" 130mm (Front) 130mm (Rear)
SEAT	"Puffo" with Adjustable Seat Guide System	"F6" Size 1 1+ 2 3 4	"Racing Mini" Size 1 2
AXLE	25x960mm	50x2x1030mm	30x5x960mm S M H
SPINDLES	17mm With Ø8 Kingpins	25mm With Ø8 Kingpins	17mm with Ø8 Kingpins & Camber-Caster Regulation Plates
WEIGHT	43 Kg (with engine & tires)	47 Kg	36 Kg

BABY

DARK

PICCOLO

INVICTUS

TACHO

DRAGON EVO

32mm High-Strength Steel Frame
(with 30mm nose bar)

30mm High-Strength Steel Frame
(with 32mm center bar)

30mm High-Strength Steel Frame

FRAME

FP7 - Stilo Top Line Model With CIK-FIA Homologated Supports

FP7 - Stilo Top Line Model With CIK-FIA Homologated Supports

FP7 - Stilo Top Line Model With CIK-FIA Homologated Supports

BODYWORK

Hydraulic Brakes With Oil Recovery Tank, Iron Cast Brake Disc

Hydraulic Brakes With Oil Recovery Tank, Iron Cast Brake Disc

Hydraulic Brakes With Oil Recovery Tank, Iron Cast Brake Disc

BRAKES

Top Line Steering System with 330mm "Le Mans" Steering Wheel

Top Line Steering System with 330mm "Le Mans" Steering Wheel

Top Line Steering System with 330mm "Le Mans" Steering Wheel

STEERING

8.5 Litres

8.5 Litres

8.5 Litres

TANK

Magnesium 5" 132mm (Front) 212mm (Rear)

Magnesium 5" 132mm (Front) 212mm (Rear)

Magnesium 5" 132mm (Front) 212mm (Rear)

WHEELS

"Racing" Sizes: 1 | 1+ | 2 | 3 | 4

"Racing" Sizes: 1 | 1+ | 2 | 3 | 4

"Racing" Sizes: 1 | 1+ | 2 | 3 | 4

SEAT

50x2x1030mm S | MS | M | MH | H | EH | X

50x2x1030mm S | MS | M | MH | H | EH | X

50x2x1030mm S | MS | M | MH | H | EH | X

AXLE

25mm with Ø10 Kingpins & Camber-Caster Regulation Plates

25mm with Ø10 Kingpins & Camber-Caster Regulation Plates

25mm with Ø10 Kingpins & Camber-Caster Regulation Plates

SPINDLES

STR configuration: 54 Kg
RBS configuration: 50 Kg

STR configuration: 54 Kg
RBS configuration: 50 Kg

STR configuration: 54 Kg
RBS configuration: 50 Kg

WEIGHT

INVICTUS

TACHO

DRAGON EVO

2015 PRAGA CHASSIS

PRAGA PICCOLO

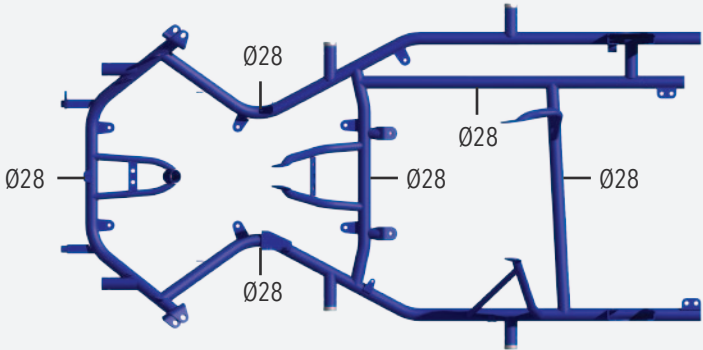

Wheelbase: 900mm, 950mm, and 1010mm

PRAGA DARK

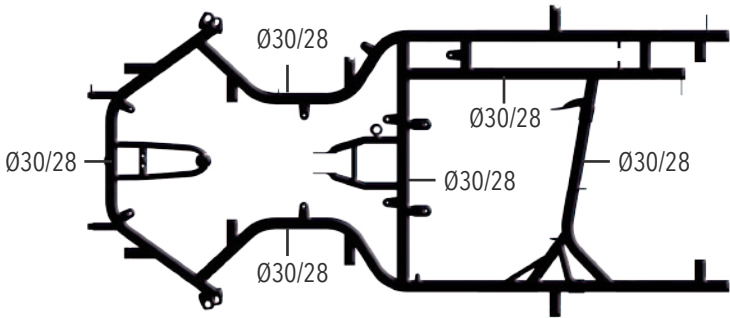

Wheelbase: 1055mm

PRAGA BABY

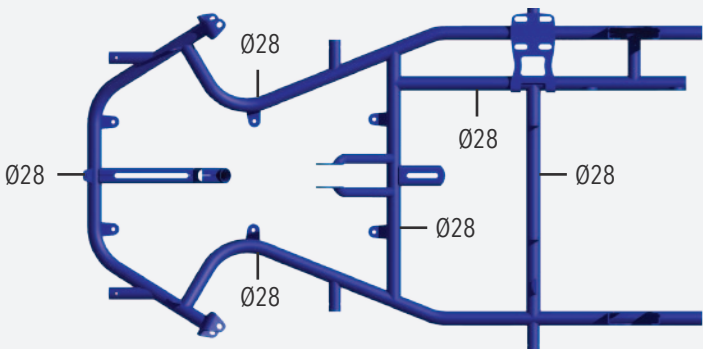

Wheelbase: 800mm

PRAGA NORTH AMERICA

2015 PRAGA CHASSIS

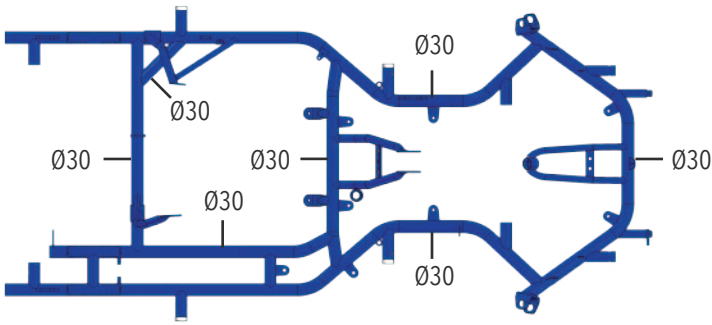

Wheelbase: 1010mm, 1045mm, and 1055mm

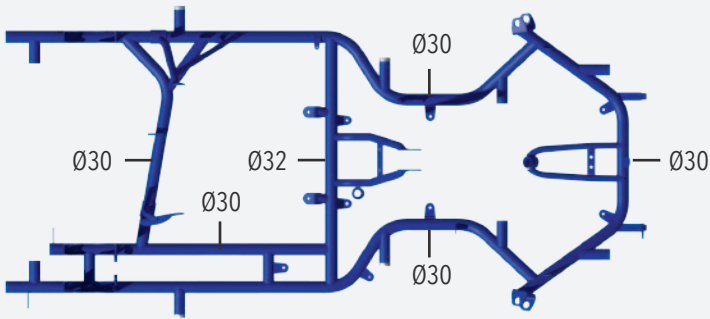

Wheelbase: 1055mm

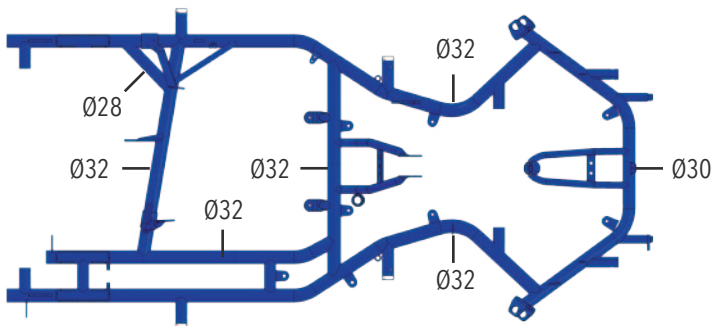

Wheelbase: 1055mm

PRAGA DRAGON EVO

PRAGA TACHO

PRAGA INVICTUS



Praga North America Race Team

The Praga North America Race Team will be attending a full schedule of national karting events for 2015, including the Florida Pro Kart Winter Series, SKUSA Pro Tour, USPKS, and Gearup F Series.

Visit our website for more information and updates on our official schedule at www.PragaNorthAmerica.com.

Arrive & Drive opportunities available throughout 2015. Experience top of the line Praga race karts and personalized service with Praga's

PRAGA NORTH AMERICA

TEAM PRAGA

Join Praga North America



Arrive & Drive program. Come be a part of the official Praga North America Race Team! Opportunities are available throughout the year for complete series and individual races. To find out more about our program and how you can sign up, contact us at (954) 326-2073 or email us at team@praganorthamerica.com.

Praga

WWW.PRAGANORTHAMERICA.COM



PRAGA MOTORS NA, LLC

2010 SW 31ST AVENUE | PEMBROKE PARK, FL 33009

T: +1 954-326-2073

E: INFO@PRAGANORTHAMERICA.COM

Praga

WWW.PRAGANORTHAMERICA.COM