

Normal Stresses, Seepage Forces and Pond Pressures in the Method of Slices or Columns

by Robert Pyke Ph.D., G.E.

April 20, 2017

Introduction

There are a number of variations of the simple, and thus approximate, method of analyzing slope stability known generically as the method of slices (or columns in 3D). The simplest of these, like the Ordinary Method of Slices (OMS), neglect side forces and define the factor of safety as the sum of the resisting forces divided by the sum of the driving forces. In 3D the OMS becomes the Ordinary Method of Columns (OMC). Then there are limit equilibrium methods, in which the factor of safety is defined as the number which, when used to factor the shear strengths, brings the driving and resisting forces into equilibrium. Limit equilibrium methods then fall into two classes, those like Bishop's Simplified Method, that do not fully satisfy both force and moment equilibrium and those, such as the Morgenstern and Price (1965) and Spencer (1967) methods, which do. But all of these methods use similar procedures to calculate the normal and shear stresses acting on the base of each slice (or column in a 3D analysis). This paper examines two alternate ways of accommodating the presence of water and pore pressures in computing the normal force on the base of a slice and thus the shear strength of frictional materials. That discussion leads to comments on how best to include seepage forces and pond pressures in these analyses.

Calculation of the Normal Effective Stress on the Base of a Slice

The classic way to compute the normal force or pressure on the base of a slice is shown in Figure 1. In order to make the impact of pore pressures clearer, this figure shows a slope that is completely submerged with a horizontal water surface located above the top of the slice. This is a hydrostatic condition. Common-sense suggests that the height of this water surface above the top of the slice should not matter because it will only increase the pore pressure at the center of the base of the slice and not the effective stresses. In this figure the "total weight of the slice" includes both the total weight of the slice itself and the weight of the slice of water

above it. The weight of the water must be included because the full depth of water will be accounted for in any normal calculation of the pore pressure. But care should be taken in subsequent calculations not to, for instance, apply a seismic coefficient to that full total weight, as was done in some early computer programs.

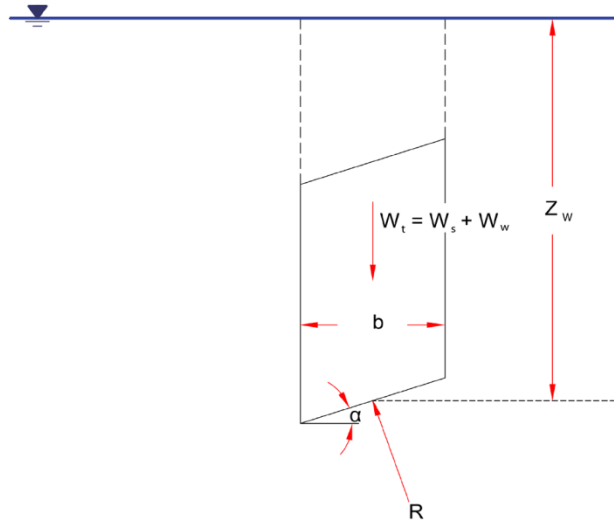

Figure 1 – Hydrostatic condition

The reaction normal to the base of the slice, R , is equal to the sum of the normal effective force and the water force acting on the base of the slice. If now we switch to stresses, the normal effective stress on the base of the slice is conventionally calculated as shown in Equation 1, where σ'_n is the normal effective stress, u is the pore pressure, equal to $\gamma_w z_w$, where γ_w is the unit weight of water and the other terms are as shown in Figure 1.

$$\sigma'_n = \frac{W_t \cos \alpha}{b / \cos \alpha} - u \quad (1)$$

However, as pointed out, for instance, by Whitman and Bailey (1967) and Duncan, Wright and Brandon (2014), this expression can lead to the calculation of negative normal forces when the angle of inclination of the base of the slice and/or the pore pressure are large. Duncan, Wright and Brandon provide a worked example to demonstrate this on their page 66. Both these sets of authors, and others, have pointed to this as a limitation of the OMS but it is equally true of all methods of analysis that use this expression. It just becomes more apparent in the OMS and it is obscured in other methods because of the way the factor of safety is defined and use of arbitrary interslice forces.

Both Whitman and Bailey and Duncan, Wright and Brandon, and others cited by them, suggest a workaround or alternate equation for the OMS in which only the buoyant unit weight of the slice is considered. The equation for the effective normal stress on the base of the slice then becomes as shown in Equation 2:

$$\begin{aligned}\sigma'_n &= \frac{(W_t - ub) \cos\alpha}{b/\cos\alpha} \\ &= \frac{W_t \cos\alpha}{b/\cos\alpha} - u \cos^2 \alpha\end{aligned}\quad (2)$$

It may be seen that the pore pressure term is now multiplied by a factor of $\cos^2\alpha$, which is unity when the base of the slice is horizontal and becomes increasingly small as the angle of inclination of the base of the slice, α , increases. This prevents the calculation of negative normal effective stresses on the base of the slices and provides results using the OMS that are closer to those obtained from limit equilibrium methods. Therefore, it would seem to make sense to use buoyant unit weights in conjunction with the OMS, but that leaves two questions hanging. One question is which of these expressions is “more correct” and the other is, if Equation 2 is the better answer for the OMS, would it not also be better in limit equilibrium methods?

The answer to the first question is simple. Equation 2 is more correct. In the first place it provides an answer that is consistent with common-sense. The normal effective stress on the base of the slice should only be a function of the buoyant unit weight of the slice itself and should not be a function of the elevation of any pond above it. The second reason is that there is a flaw in the development of Equation 1. Water is a fluid and fluid pressures act in all directions. You cannot resolve a fluid pressure or any forces derived from them into components. It is in doing that that the two $\cos\alpha$ terms get cancelled out in Equation 1.

The answer to the second question is more complex. It might well be “better” in some sense to use buoyant unit weights in limit equilibrium analyses also, but for most problems it may not make much difference, and there is accumulated experience that has been developed using these methods with total unit weights. Application of the pore pressures normal to the bases of the slices in conventional limit equilibrium analyses also gives the impression that this accounts for seepage forces in non-hydrostatic conditions. However, as explained in the next section this is not correct. The seepage forces that one assumes might be applied by using total unit weights and specifying the pore pressures along the slip surface do not actually make their way into the analysis. Thus, it is an open question whether or not it might be better to use

buoyant unit weights and omit the pore pressures on the bases of the slices in limit equilibrium analyses.

In the case of non-hydrostatic conditions, as shown in Figure 2, any seepage forces in the vertical direction have to be added or subtracted to the weight of the slice computed using buoyant unit weights because the pore pressure at the base of the slice is no longer equal to $\gamma_w z_w$. This difference may not be large. It can be approximately calculated as $\gamma_w z_w \sin^2 \theta$ so that the pore pressure u is then given by $\gamma_w z_w \cos^2 \theta$, when the slope of the phreatic surface, θ , is small, but it becomes larger as θ increases and should then probably be computed from a flownet or a numerical analysis. The vertical seepage force can then be calculated as, for instance, explained by Lambe and Whitman (1969) but in practice it might be more convenient to compute what we might call the “buoyant weight adjusted for seepage forces” by using the total unit weight and then subtracting the vertical water pressure that acts on the base of the slice. This procedure can also be used for cases like that shown in Figure 1 when there is water above the slice. Then the vertical water pressure on the top of the slice should be added and the vertical water pressure on the bottom of the slice should be subtracted from the weight of the slice calculated using total unit weights. But all this should be done before calculating the component of the weight of the slice that acts normal to the base of the slice. Either of these approaches is relatively simple to apply and is recommended for use with the OMS. Again, it is unclear what the effect will be and whether it is worth changing the traditional approach of just using the total unit weights and the pore pressures at the bases of the slices in limit equilibrium methods.

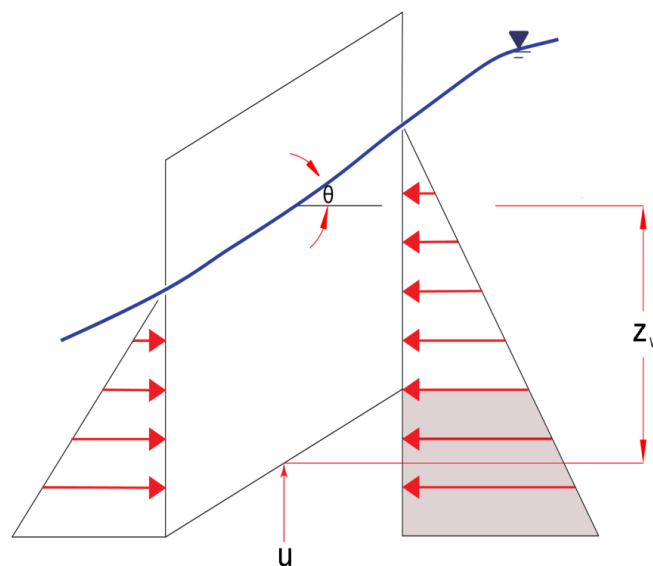

Figure 2 – Non-hydrostatic condition

Seepage Forces

The assertion made above that the seepage forces that one assumes might be applied by using total unit weights and specifying the pore pressures along the slip surface in non-hydrostatic conditions do not actually make their way into limit equilibrium analyses can easily be checked by running an analysis of a cohesive slope with varying phreatic surfaces. However steep the phreatic surface, it will make no difference to the computed factor of safety in a standard limit equilibrium analysis. The reason that a slope in which all the strengths are specified as fixed quantities such as cohesions or undrained shear strengths must be used is that the strength of frictional materials will vary with the normal effective stress, so that changing the phreatic surface will make a difference to the shear strengths, but it does not make a difference to the limit equilibrium problem. The writer and his then colleagues learnt this the hard way some years ago by trying to include excess pore pressures generated by earthquake loading in the second stage of a two stage analysis. Once the programming was completed we found that it made no difference to the calculated factor of safety!

This problem related to seepage forces was noted by King (1989) and is most simply explained by saying that if the seepage forces are pictured as boundary water pressures, the corresponding forces will be applied at the center of the base of each slice and they make no difference to the standard equations of equilibrium. They make no difference to the moment because the moment arm is zero and they are not included in the solution for force equilibrium parallel to the base of the slice. They make no overall difference to force equilibrium normal to the base of the slice because the force due to the weight of the slice is fixed and increasing the pore pressure simply reduces the effective stress, which may change the calculated shear strength, but doesn't impact the solution of the equations of equilibrium. King suggested a solution which involved calculating the distributed seepage forces and applying them at the appropriate height in each slice, but this is a little unwieldy and requires a companion seepage analysis, so that his proposed solution has never caught on.

In the OMS, however, it is easy to specify the seepage forces as horizontally applied loads on each slice, as shown in Figure 2. Note that the seepage forces in the vertical direction have already been taken into account as discussed above. The horizontal seepage forces could be applied over the full height of the portion of each slice that is below the phreatic surface, as shown in Figure 2, or, since the bulk of these forces will cancel out over the entire potential sliding mass, only the shaded portion acting on the base of the slide need be applied. The conventional wisdom is that one either uses buoyant unit weights and distributed seepage forces or total unit weights and boundary pressures, but that only applies to vertical flow as in the example given by Lambe and Whitman (1969) on their page 262. In this case where the seepage forces are applied horizontally it does not matter whether total or buoyant unit

weights have been used to compute the normal forces on the potential slip surface as they are separate calculations. If the forces corresponding to the shaded portion of the pressure distribution are then added vectorially, they will act in a direction that corresponds to the average direction of the seepage forces obtained from a flownet or numerical seepage analysis.

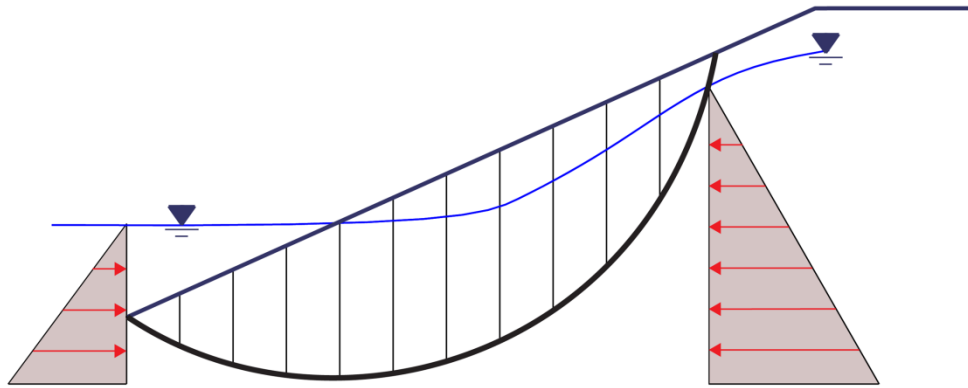

Figure 3 – Seepage Forces with Pond

In the case where there is a pond at the bottom of the slope, the seepage forces should be applied to both the bases of the slices that are coming up at the toe of the potential slide and to the tops of the slices that are below water, as shown in Figure 3. In Figure 3 all the seepage forces have been set back outside the potential slip surface for clarity, but they should be applied as forces acting at the center of the base or top of the relevant slice. These are “active” forces that should be added to or subtracted from the sum of the driving forces in the denominator of the equation for the factor of safety in the OMS or the OMC. In the hydrostatic case, whether the water surface runs through the potential slide or is located above it, all the seepage forces will of course cancel.

Pond Pressures

The fact that in Figure 3 a horizontal loading is applied to the tops of the slices might imply that the pressures exerted by a pond on the face of the slope are accounted for, but this is not necessarily the case. With the OMC such forces are readily accounted for, but it is less than clear whether and how they are applied in limit equilibrium methods.

For the special case of an impervious face such as a concrete-faced dam or a lined pond, where the water in the pond does not connect to a phreatic surface within the slope, the pond pressures need to be applied separately, and should now be applied as a passive support, increasing the resisting forces. In limit equilibrium methods it is difficult to impossible to know

what effect, if any, pond pressures might have on the normal stresses on the potential slip surface and hence the shear strengths, but with the OMS or the OMC the user can specify an appropriate distribution of pressures on the bases of affected slices for the purpose of computing the shear strengths, since that can be an independent calculation. The resulting loads are illustrated in Figure 4.

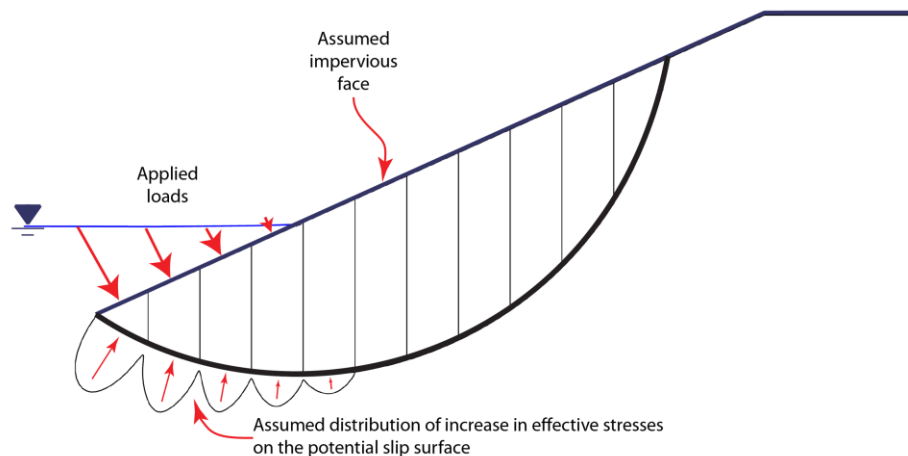

Figure 4 – Application of Pond Pressures

Conclusions

The apparent inconsistency between the two possible ways of applying the unit weight of the material involved in a potential slide has been discussed and resolved. It is more robust and accurate to use buoyant unit weights, particularly with the OMS. It is unclear what effect this might have on methods of analysis that fully satisfy equilibrium.

It is difficult to apply seepage forces in limit equilibrium analyses; however, it is relatively easy to apply them with the OMS.

The question of applying pond pressures is more complicated than is commonly assumed. Again, it is relatively easy to suggest ways of covering the extreme conditions of a porous face or an impervious face with the OMS. but it is unclear what happens when pond pressures are applied in a limit equilibrium analysis.

References

Duncan, J.M., Wright, S.G. and Brandon, T.L. "Soil Strength and Slope Stability, 2nd Edition", ISBN: 978-1-118-65165-0, Wiley, September 2014

King, G.J.W., "Revision of the effective-stress method of slices", Geotechnique, Vol. 39, No. 3, 1988

Morgenstern, N.R., and Price, V.E., "The Analysis of the Stability of General Slip Surfaces", Geotechnique, Vol. 15, No. 1, pp.79-93, 1965

Pyke, R., "Pros and Cons of the Analysis of Slope Stability by Various Methods of Slices or Columns", Draft Report posted on <http://rpce.us>, April 2017

Spencer, E., "A Method of Analysis of the Stability of Embankments Assuming Parallel Inter-Slice Forces", Geotechnique, Vol. 17, No. 1, pp. 11-26, 1967

Whitman, R.V., and Bailey, W.A., "Use of Computers for Slope Stability Analysis." Proc. ASCE, Vol. 93, No. SM4, July 1967

Lambe, T.W., and Whitman, R.V., "Soil Mechanics", John Wiley & Sons, Inc., New York, 1969