

NOTES FOR SHEET 1:

- 1) The architecture of this receiver is *loosely* based on a Drake 2-B front end up to the output of the second mixer (V4), and a Collins 75S-3 after this point. Hence the name "75S-2B".
- 2) Preselector range (C1A and C1B) is 3.5 to 30 MHz in four ranges (15 and 10 meters use same range).
- 3) First IF range (C2A and C2B) is 3.5 to 4.0 MHz.
- 4) VFO operating range (C2C) is 3.955 to 4.455 MHz.
- 5) "T" denotes parallel trimmer capacitor on sides of C1A&B and C2B&C.
- 6) V2A operates as a mixer on 40 thru 10 meters with injection from V2B xtal oscillator. On 80 meters xtal oscillator is disabled and V2A operates as a straight thru amplifier.
- 7) Second IF is 455 kHz.
- 8) An asterisk * denotes silver mica type capacitor.
- 9) Solid state/Arduino modules on sheet 2 provide digital frequency readout and BFO injection signal.

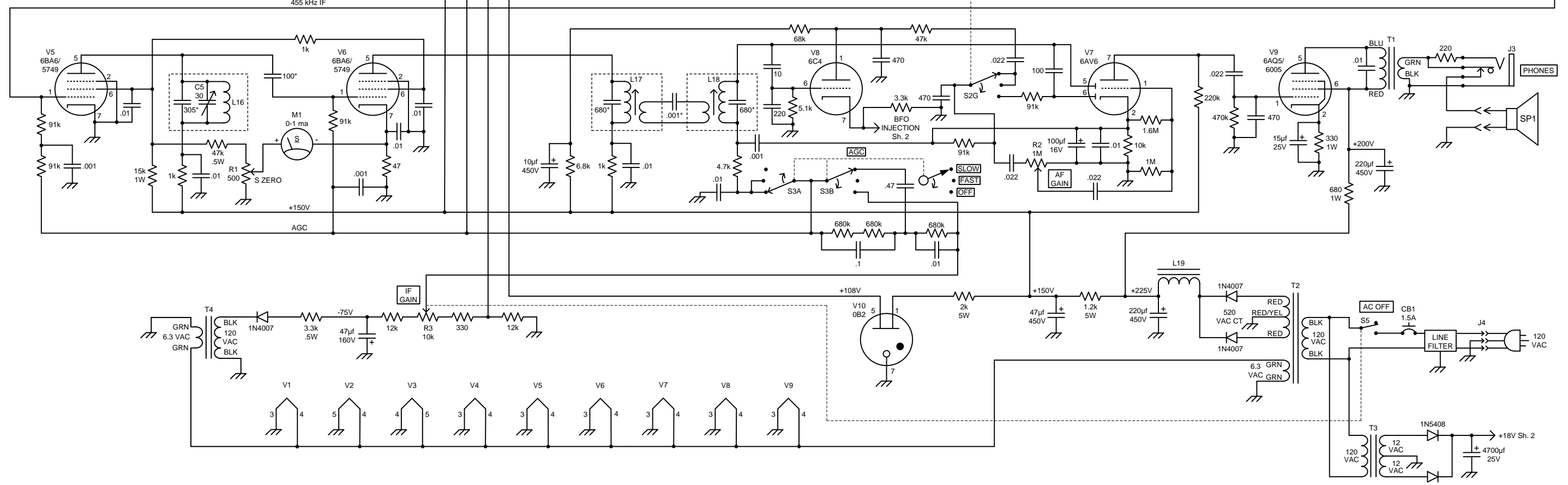

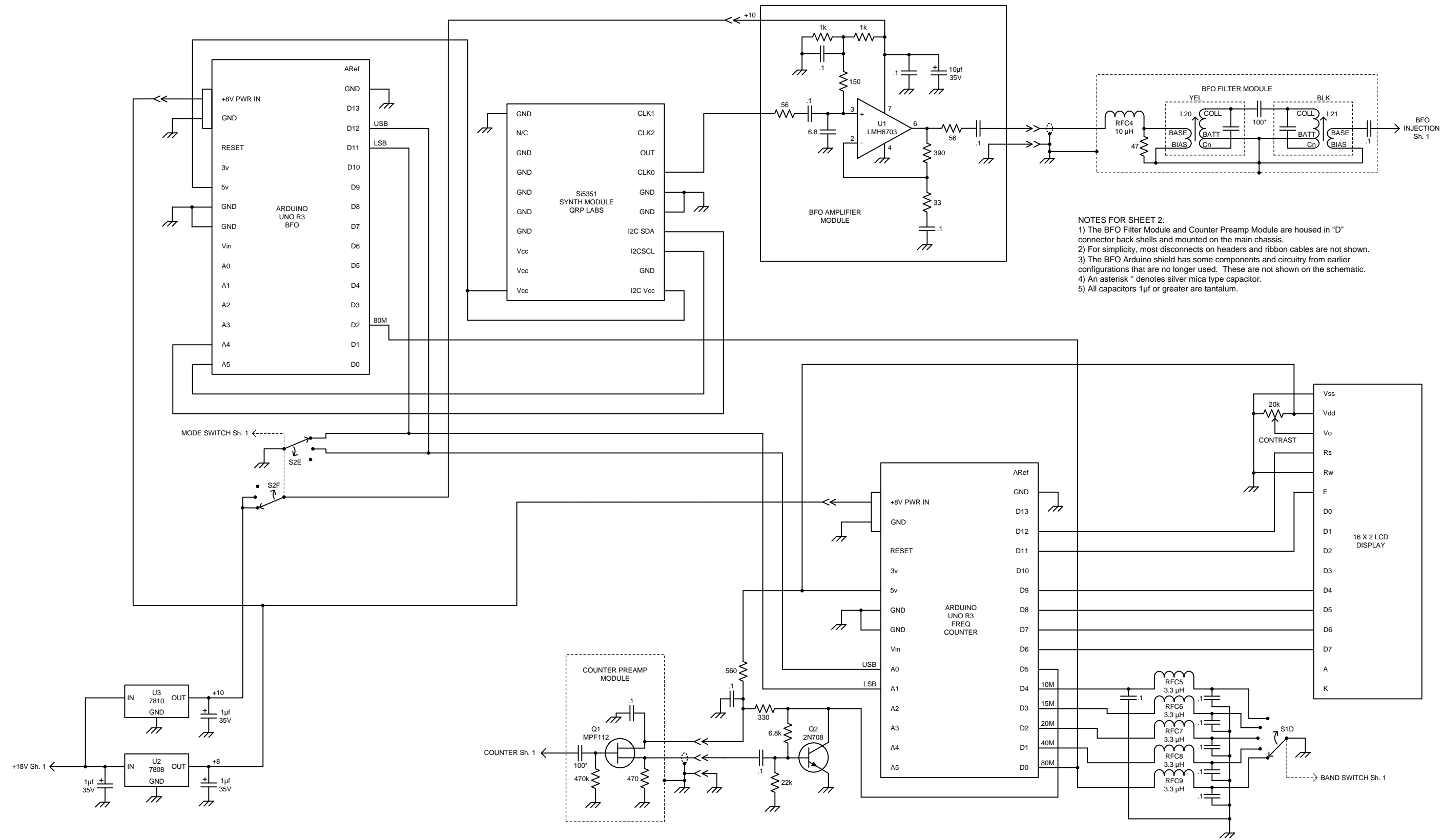

NOTES FOR SHEET 2:
 1) The BFO Filter Module and Counter Preamp Module are housed in "D" connector back shells and mounted on the main chassis.
 2) For simplicity, most disconnects on headers and ribbon cables are not shown.
 3) The BFO Arduino shield has some components and circuitry from earlier configurations that are no longer used. These are not shown on the schematic.
 4) An asterisk * denotes silver mica type capacitor.
 5) All capacitors 1µf or greater are tantalum.