

Agenda for the Regular Meeting of the Council of the Village of Gold River to be held Monday, February 4, 2019 in Council Chambers, Municipal Hall, 499 Muchalat Drive, Gold River B.C. commencing at 7:00 p.m.

CALL TO ORDER

Dale Frame – Hatchery Proposal Presentation

INTRODUCTION OF LATE ITEMS

APPROVAL OF AGENDA

ADOPTION OF MINUTES

Minutes of the Regular Council Meeting held January 21, 2019

REPORTS

Councillor B. Patrick – Vancouver Island Regional Library AGM Meeting

M. McLean, Deputy Treasurer – Payment of Accounts December 2018

M. McLean, Deputy Treasurer – Payment of Accounts January 2019

Reg Stratton, Straight Grain – Nimpkish Park Pavilion Proposal

COUNCIL INFORMATION ITEM

Mayor Unger – Family Day

BYLAWS

CORRESPONDENCE

1. Roger Steele – Regarding Cell Service Correspondence
2. Rachel Blaney, MP – Continuous Cellular Coverage Highway 19

NEW BUSINESS

MOTION TO ADJOURN IN CAMERA

RISE AND REPORT

TERMINATION

Minutes of the Regular Meeting of the Council of the Village of Gold River held Monday, January 21, 2019 in Council Chambers, Municipal Hall, 499 Muchalat Drive, Gold River B.C. commencing at 7:00 p.m.

PRESENT: Mayor B. Unger
Councillor K. Begon
Councillor R. Stratton
Councillor B. Patrick
Councillor J. Sinclair

STAFF: M. McLean, Deputy Corporate Officer

CALL TO ORDER

The meeting was called to order at 7:00 p.m.

APPROVAL OF AGENDA

MOVED and seconded that the agenda be approved as presented.

CARRIED

ADOPTION OF MINUTES

Minutes of the Regular Council Meeting held January 7, 2019.

MOVED and seconded that the minutes be adopted as circulated.

CARRIED

Minutes of the Special Council Meeting held January 15, 2019.

MOVED and seconded that the minutes be adopted as circulated.

CARRIED

REPORTS

R. Stratton, Economic Development Corporation – Funding Request

MOVED and seconded that the report be received.

CARRIED

MOVED and seconded that Council approve the funding request from the Economic Development Committee for up to \$600 to purchase large calendars to be used for Public Event notifications around town.

CARRIED

B. Unger, Mayor – Strathcona Regional District regarding letter from Gold River Chamber of Commerce

MOVED and seconded that the report be received.

CARRIED

MOVED and seconded that Mayor Unger respond to the President of The Chamber of Commerce regarding email/letter sent to the Strathcona Regional District.

CARRIED

L. Illes, Fire Chief – 4th Quarter 2018 – Fire Department Report

MOVED and seconded that the report be received.

CARRIED

Administrator/Emergency Coordinator – UBCM Grant – Emergency Operations Centre

MOVED and seconded that the report be received.

CARRIED

MOVED and seconded that the application for financial assistance under the Community Emergency Preparedness Fund Grant for Emergency Operations Centres be authorized for submission to the Union of BC Municipalities AND that the Village of Gold River agree to provide management of the grant funds if the application is successful.

CARRIED

COUNCIL INFORMATION ITEMS

Memorandum of Understanding with Mowachaht Muchalat First Nation for a Community Forest Licence Agreement was signed by Council.

CORRESPONDENCE

1. Ken Pringle, President CUPE 3399 – Request for employees to be granted free use of Anne Fiddick Aquatic and Sports Centre
2. Vancouver Island Regional Library – Library Budget and Levy to Members
3. West Coast Environmental Law – Local Climate Change Impacts and the Fossil Fuel Industry

4. AVICC – Resolutions Notice Request for Submissions
5. AVICC -- 2019 AGM & Convention, Call for Nominations for AVICC Executive
6. Island Health – B.C. Vision Zero Summit
7. RCBC, Recycling Council of British Columbia – 45th Annual Zero Waste / Circular Economy Conference 2019

MOVED and seconded that the Correspondence be received.

CARRIED

MOVED to provide free facility use of the Anne Fiddick Aquatic & Sports Centre to Village of Gold River Employees.

NO SECONDER

TERMINATION

MOVED and seconded that the meeting terminate.

Time: 7:40 p.m.

CARRIED

B. Unger

Mayor

M. McLean

Deputy Corporate Officer

Certified correct by the Deputy Corporate Officer

M. McLean

Deputy Corporate Officer

RECEIVED

JAN 25 2019

VILLAGE OF
GOLD RIVER

Report to Council

Councillor Patrick: Vancouver Island Regional Library, Annual General Meeting 2019

On January 19th, 2019 I attended the Vancouver Island Regional Library Annual General Meeting. As there has been a large turnover of members new executives were appointed. Three of these new appointees were at the same table I was at and have been with the board for some time. The reason I mention this is to comment how highly these people spoke of our former councillor and past VIRL Executive member Gordie Waterman.

The VIRL is moving in new directions and has implemented some very exciting goals and objectives. The 2019 Budget is themed as "INNOVATION AND INSPIRATION" and from what I witnessed, it is that! The library is to be recognized as a "vibrant civic space" that is relevant, responsive, and sustainable. Since 2011 there have been 11 branches that have either been renovated or built new. The VIRL website was updated November of last year and with your library card you will be able to access a variety of digital media which I look forward to exploring.

The financial information as presented shows that there is a per capita increase of \$1.48. For every dollar spent \$0.47 is on wages and benefits, \$0.03 on computer costs, \$0.04 on interest, \$0.05 is administrative costs, \$0.09 on library materials, \$0.12 projects funded by reserve, \$0.11 appropriations, and \$0.09 is branch facility costs. The 2019 budget identifies a levy increase of 4.74%: 2.6% to core services, 1.36% to facilities, and 0.77% to new budget requests.

Library demographic membership for the Village of Gold River is 15% kids, 17% teens, and 68% adults. The VIRL system wide demographic is 11% kids, 5% teens, and 84% adults. I found this very encouraging for our community's youth. The number of program attendees was 1,187, there were 14,886 physical items checked out, and a total of 10,114 visitors. WIFI access is recorded at 111 GB. This information shows a decline but is not given in a percentage or number.

The AGM meeting overall was very professional, informative, and quite enjoyable. I was able to visit the numerous booths that showcased some of the new technology being offered. I would recommend taking a look at the new website www.virl.bc.ca. The new items that are coming can be checked out and taken home or used during the visit to the library. There are new educational technical toys that many families would find too expensive to purchase. The virtual reality goggles that can be ordered to the library were on display and I was impressed with the experience. Interactive toys that promote hand-eye coordination, toys to assist children with autism to focus, or to learn mathematical processes with geometric magnetic pieces and using computer coding techniques to play were also on display.

If you do not have a library card, please visit the Gold River Library branch (take your identification) and get your library card.

Brenda Patrick

Village of Gold River
AP Cheque Listing for December 2018

Cheque #	Vendor Name	Paid Amount
Telus Nov 2018	Telus	1,339.73
Linde2100075437	Linde Canada Limited 15687	815.24
043141	ACKLANDS - GRAINGER INC.	3,793.26
043142	AlSCO	58.09
043143	Associated Engineering B.C. Ltd.	7,392.00
043144	A-Mais Technologies Inc.	5,918.08
043145	Carmac Diesel	1,256.97
043146	CROSS, DOUG	380.32
043147	Commercial Aquatic Supplies	223.90
043148	Fastenal Canada, LTD	236.11
043149	FINELINE GRAPHICS & COMPUTER SALES	102.38
043150	Five Star Uniforms	110.25
043151	FIRE CHIEFS' ASSOCIATION OF B.C.	742.49
043152	Gold River Revellers Seniors Society	250.00
043153	GUILLEVIN INTERNATIONAL	708.75
043154	Grant Illuminated Signs Ltd	111.45
043155	H.B. Energy	2,793.65
043156	Haines, Courtenay	20.00
043157	Inland Kenworth Campbell River	358.38
043158	Iridia Medical	105.00
043159	Innov8 Digital Solutions Inc.	170.18
043160	James R. Craven & Associates Ltd.	2,546.25
043161	Kal Tire	690.19
043162	Kargus, Kelsey	74.89
043163	Lott, Francesca	202.94
043164	McPherson, Tim	25.61
043165	North Island Communications Inc.	2,867.27
043166	O'REILLY, KATHLEEN	142.96
043167	Perchaluk, Linda	800.00
043168	PLOURDE, LARRY	98.28
043169	Raleigh Fire Safety Ltd.	419.56
043170	ROSE, JAN	67.01
043171	The Edge Sharpening Co.	140.33
043172	Uline Canada Corporation	1,904.45
043173	Vandenberg, Linda	290.39
043174	Williams, Victoria	175.00
043175	Watt, Lena	53.61
Xplor 24576562	Xplornet Communications Inc.	127.67
043176	Murphy, Kevin	1,000.00
MPP Dec14/18Pay	Municipal Pension Plan	5,207.30
SP Ord#135376	Superior Propane Inc.	2,095.92

Village of Gold River
AP Cheque Listing for December 2018

Cheque #	Vendor Name	Paid Amount
PBC Dec 2018	Pacific Blue Cross	6,901.31
MSP Dec 2018	Minister of Finance	900.00
SP Ord#141611	Superior Propane Inc.	3,120.29
043110	1st Class Driving School	660.00
043111	Alsco	110.10
043112	Conuma Cable Systems Ltd.	257.44
043113	Carmac Diesel	164.70
043114	Cloverdale Paint Inc.	364.67
043115	COMOX PACIFIC EXPRESS LTD.	51.87
043116	Churchill, Tony	250.70
043117	CANADA POST	525.00
043118	C.U.P.E. LOCAL 3399	1,712.21
043119	FINELINE GRAPHICS & COMPUTER SALES	68.25
043120	Fox, Matthew	400.70
043121	GOLD RIVER BUILDER'S SUPPLY LTD.	485.05
043122	GUILLEVIN INTERNATIONAL	76.79
043123	GOLD RIVER VOLUNTEER FIRE DEPARTMENT	20.16
043124	GOLD RIVER AUTO PARTS PLUS LTD.	3,701.31
043125	GAIGA, ROMEO	100.00
043126	Havers Design	115.50
043127	Inland Kenworth Campbell River	262.13
043128	Innov8 Digital Solutions Inc.	75.22
043129	Loomis Express	548.10
043130	LIFESAVING SOCIETY	192.39
043131	MacLeod, Desiree	37.65
043132	Mellis-Jones, Lisa	248.36
043133	Maxxam Analytics	2,640.75
043134	Neill, John	351.40
043135	Osborne Electro-Mechanics Ltd.	125.42
043136	QUINSAM COMMUNICATIONS GROUP	50.40
043137	Smith, Ken	2,173.00
043138	TRUEMAN, JAN	100.00
043139	A.C.E. Courier Services	75.54
043140	Trueman, Wayne	163.96
Act Fee Nov2018	RBC Royal Bank	97.70
MPP Nov30/18Pay	Municipal Pension Plan	5,301.65
PST Nov 2018	MINISTER OF FINANCE	82.85
Visa Dec 2018	Royal Bank Visa	5,000.00
CMF Inv692080	CR92 Holdings DBA Coastal Mountain Fuels	2,799.64
CRA Nov16/18Pay	Receiver General for Canada	11,669.83
CRA Nov30/18Pay	Receiver General for Canada	11,283.43

Village of Gold River
AP Cheque Listing for December 2018

Cheque #	Vendor Name	Paid Amount
CRA Dec14/18Pay	Receiver General for Canada	15,327.76
Hydro Nov 2018	BC Hydro	25,899.87
Dedj Nov 2018	Desjardins Card Services	1,294.40
SP Ord#237132	Superior Propane Inc.	2,436.45
BankFee Dec/18	Moneris Solutions	104.14
Visa Dec b 2018	Royal Bank Visa	771.06
		154,915.01

Respectfully Submitted



Maxine McLean
Deputy Treasurer

Village of Gold River
January 2019 AP Cheque Listing

Cheque #	Vendor Name	Paid Amount
043177	Alsco	179.92
043178	Associated Fire Safety	7,678.73
043179	ANDERSON REFRIGERATION LTD.	563.64
043180	Barbeau-Lafaci, Sarah	100.00
043181	Collins, Kyle	770.00
043182	Cole-Parmer Canada Company	805.04
043183	C.U.P.E. LOCAL 3399	1,177.64
043184	Commercial Aquatic Supplies	372.79
043185	FEDERATION OF CANADIAN MUNICIPALITIES	461.70
043186	George, Addison	45.95
043187	H.B. Energy	2,722.41
043188	ITM Instruments Inc	278.88
043189	Kargus, Kelsey	90.27
043190	Keywords Lock Service	315.33
043191	Loomis Express	116.07
043192	LIFESAVING SOCIETY	434.57
043193	Lott, Francesca	99.75
043194	Mellis-Jones, Lisa	100.41
043195	Maxxam Analytics	462.00
043196	Municipal Insurance Association of	8,394.00
043197	Planet Clean	517.95
043198	PETTY CASH	214.50
043199	R.H. Printing Ltd.	88.70
043200	Strathcona Regional District	1,113.30
043201	ACKLANDS - GRAINGER INC.	713.95
043202	Alsco	58.09
043203	Andrew Sheret Limited	346.24
043204	BRENNTAG CANADA INC.	4,933.81
043205	Conuma Cable Systems Ltd.	257.44
043206	DISCOVERY SPECIALTY ADVERTISING	1,050.95
043207	Fastenal Canada, LTD	155.75
043208	FIRE CHIEFS' ASSOCIATION OF B.C.	246.00
043209	GOLD RIVER BUILDER'S SUPPLY LTD.	1,539.05
043210	GFOA of BC	220.50
043211	GCS Technology Services Inc.	55.65
043212	Get-r-Done Plumbing	267.75
043213	GOLD RIVER VOLUNTEER FIRE DEPARTMENT	8,750.00
043214	Gold River Curling Club	1,124.40
043215	GOLD RIVER AUTO PARTS PLUS LTD.	1,336.05
043216	H.B. Energy	402.14
043217	Innov8 Digital Solutions Inc.	161.41

Village of Gold River
January 2019 AP Cheque Listing

Cheque #	Vendor Name	Paid Amount
043218	Kal Tire	357.56
043219	KOERS & ASSOCIATES ENGINEERING LTD.	3,348.85
043220	Loomis Express	324.89
043221	LIFESAVING SOCIETY	120.00
043222	LGMA Vancouver Island Chapter	69.99
043223	LGMA	157.50
043224	Maxxam Analytics	161.70
043225	Planet Clean	1,521.09
043226	R.H. Printing Ltd.	266.01
043227	Staples Advantage Canada	619.56
043228	Sinclair, Sandy	174.38
043229	Vimar Equipment Ltd.	1,360.86
043230	Comox Valley Regional District	4,787.50
043231	Gold River Revellers Seniors Society	224.39
043232	Alsco	121.83
043233	Andrew Sheret Limited	97.83
043234	Bohn, Chris	708.75
043235	BC Fire Training Officers Association	157.50
043236	Campbell River Boatland (1982) Ltd.	4,969.05
043237	CMJ EQUIPMENT LTD.	682.50
043238	C.U.P.E. LOCAL 3399	1,172.86
043239	CIVICINFO BC	143.85
043240	GOLD RIVER CARPET & UPHOLSTERY CLEANING	1,785.00
043241	GUILLEVIN INTERNATIONAL	119.21
043242	Grant Illuminated Signs Ltd	263.22
043243	Heart and Stroke Foundation	40.50
043244	Inland Kenworth Campbell River	191.36
043245	Irwin Air Ltd.	107.94
043246	KOERS & ASSOCIATES ENGINEERING LTD.	2,158.15
043247	Kelly, Mark	205.26
043248	Loomis Express	117.93
043249	Lorena P.D. Staples, Q.C.	405.13
043250	Lott, Francesca	118.18
043251	Mellis-Jones, Lisa	33.76
043252	Maxxam Analytics	242.03
043253	Osborne Electro-Mechanics Ltd.	604.80
043254	O'REILLY, KATHLEEN	71.48
043255	Raleigh Fire Safety Ltd.	3,639.77
043256	ROSE, JAN	436.97
043257	Steve Marshall Motors 1996 Ltd.	4,244.60
043258	SOCAN	117.52

Village of Gold River
January 2019 AP Cheque Listing

Cheque #	Vendor Name	Paid Amount
043259	Team Aquatic Supplies Ltd	435.68
043260	United Rentals of Canada Inc.	1,584.24
043261	Volunteer Firefighters Association of BC	140.00
043262	Vandenberg, Linda	201.04
043263	Watt, Lena	53.61
043264	Western Equipment Ltd.	54.43
Total Accounts Paid for January 2019		\$ 87,642.99

Respectfully Submitted,

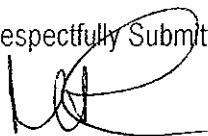

Maxine McLean
Deputy Director Finance

NIMPKISH PARK PAVILION
PROPOSAL 2019
18 feet X 22 feet
January 22 2019

Introduction

In the spring of 2017 I was approached by Gold River parks and recreation manager Micky Mann requesting assistance with the proposed Nimpkish Park pavilion project. There were a number of different pre-manufactured options which varied both in size and method of construction. I was asked to estimate construction costs and to consider suitability of design with respect to Gold Rivers geographic location. There were common issues with the pre-manufactured pavilions. Many of the suppliers were out of country which creates a number of potential shipping and Canadian Standards issues. However, the single biggest issue was engineering. Buildings from the south are not engineered for this location and therefore unsuitable for consideration.

The following year, July 2018, Micky was looking into another pavilion option through a company based out of Vancouver? This structure was 20 feet X 34 feet and steel frame. I believe this proposal went before council but was exceeding allowable budget? There may have also been an issue with having it built to meet our code requirements.

I will mention, I was not involved in sourcing manufactures or suppliers and did not speak directly with any of the companies considered. I was simply answering Micky's questions, and looking over plans as he provided them.

The pavilion project continues to interest me, and I believe it would be a valuable addition to Nimpkish park. I have provided drafted plans for counsels consideration incorporating both design and size similar to the pre manufactured structures previously considered. This plan is free of charge exclusively to the Village Of Gold River.

I am also proposing a joint construction effort to minimize costs. The Village can supply materials and equipment including labor as available. I have worked jointly with the Village in the past and understand labor and equipment availability can be limited. I would bill out a flat labor rate for myself, and additional help as needed. The labor rate includes insurance and WCB. My time spent corresponding with the Village and or engineer through the planning process will be at no cost to the Village. I have included an estimated cost of labor and materials as outlined above. I have also included a detailed list of materials.

If the Village wishes to move forward, the next process will be engineering. This cost would be covered by the Village and is essential for confirming structural design and expected cost. This structure is based on similar designs I've had engineered in the past and I do not expect any drastic changes.

Plan Details

To begin, I should explain our situation here in Gold River. We live in a region with moderate to heavy snow loading requirements. Not only for Vancouver Island, but BC in general. According to our regions climate data, snow loading (Ss) in combination with combined snow and rain (Sr) is 3.2 kpa. (67 psf), the same as Prince George. We also have regional seismic requirements to meet.

The size, 18' x 22' is for maximum efficiency. The spans and loading are at the maximum allowable in accordance with the BC Building Code. Increasing size will increase spans and require more posts, this in turn will dramatically increase costs.

18 x 22 is the footprint. 22 x 26 is the roof coverage.

Ground loading is also a consideration, this is the combined weight of the structure itself including all other forces such as rain, snow, wind and or any combination of the three. The required soil bearing capacity will be minimum, however, some ground improvement may be required. If required, the ground can be excavated, compacted and built up in a series of compacted lifts to footing grade.

All framing members are nominal size, Rough cut Fir. Timber connections are made with .25" steel plate and bolts. Complicated and time consuming timber joinery is at a minimum, however the structure will still retain a "Timber Frame" appearance.

There are a few options with the roofing, I have included hidden fastener standing seam metal for overall cost and functionality. This roof requires minimal labor to install, minimal maintenance, and has a service life equal to the structure itself.

Asphalt shingle will save on material cost, but adds weight and will require maintenance and or replacement at some point. This would be my second choice.

Cedar shakes are labor intensive to install, require maintenance and are a potential fire hazard.

The wood post to concrete connection is a moment resisting connection designed to resist side to side movement. I will need to discuss the connection details further with the engineer in order to estimate cost of fabrication. This connection is the most critical within the framework.

I would also recommend a solid concrete slab within the footprint.

Sincerely
Reg Stratton

Additional notes

Estimated pavilion size is 18 x 22 (396 sq') footprint and 22 x 26 (572 sq') covered roof area.

There are 3 options for increasing size.

(a) Supplied timber material as quoted through GRBS are longer than required. For example; 18 foot x 8" x 12" fir cross beams are supplied as 20 foot, as are the 2 x 10 collar ties etc. This timber will need to be cut down to the required 18 foot lengths.

Utilizing the full length of timber supplied, we could consider widening the building to 20feet instead of 18 feet. The only additional cost would be in the roofing. Pavilion size would be 20' x 22' (440 sq').

(b) Increasing the length by 11 feet. Assuming a rough square foot price of about \$80.00, and considering a joint construction effort with the Village, this would add \$16,000.00.

Original ball park estimate, \$32,000 for 396 sq'. Increase by 11' ~ 18 x 33 (594 sq') \$48,000.00. This would make the pavilion an 8 post structure.

(c) Combining the two options. Increase width and length. 20' x 33' 660 sq' footprint.

Increasing the size would need to be discussed further with the engineer. The options mentioned above are the absolute maximum with this structure design.

Materials 18' x 22' timber pavilion

Materials referenced as per NBCC. (National building code Canada).
(All materials to be confirmed suitable by structural engineer).

Rough Douglas Fir No.1 or select structural.
Posts to be FOHC
Beams HC acceptable

Acceptable species:

Western Hemlock ~ select structural. No.1
Amabilis Fir ~ select structural. No.1
Balsam Fir ~ select structural. No.1
Alpine Fir ~ select structural. No.1

6 ~ 8" x 8" x 8 foot
2 ~ 8" x 12" x 20 foot (actual 8x12x 18 foot)
4 ~ 8" x 12" x 16 foot (actual 8x12x 14 foot)
6 ~ 6" x 6" x 8 foot
10 ~ 2" x 10" x 20 foot (actual 2x10x 14 foot)
6 ~ 2" x 10" x 16 foot (actual 2x10x 14 foot)
26 ~ 2" x 8" x 16 foot (actual 2x8x 14 foot)
8 ~ 2" x 8" x 12 foot

2" x 6" T&G Roof decking. 1850 lin. Alternative, 1" x 6" or 1" x 8" Cedar 780 sq'

Total BF supplied 4260 (10m³) Available lengths.

Total BF custom cut 4040 (9.53m³) Actual lengths.

Custom milled (green) timber to be seasoned minimum 12 months.
All timber must be graded and have acceptable appearance.
FOHC. (free of heart center).

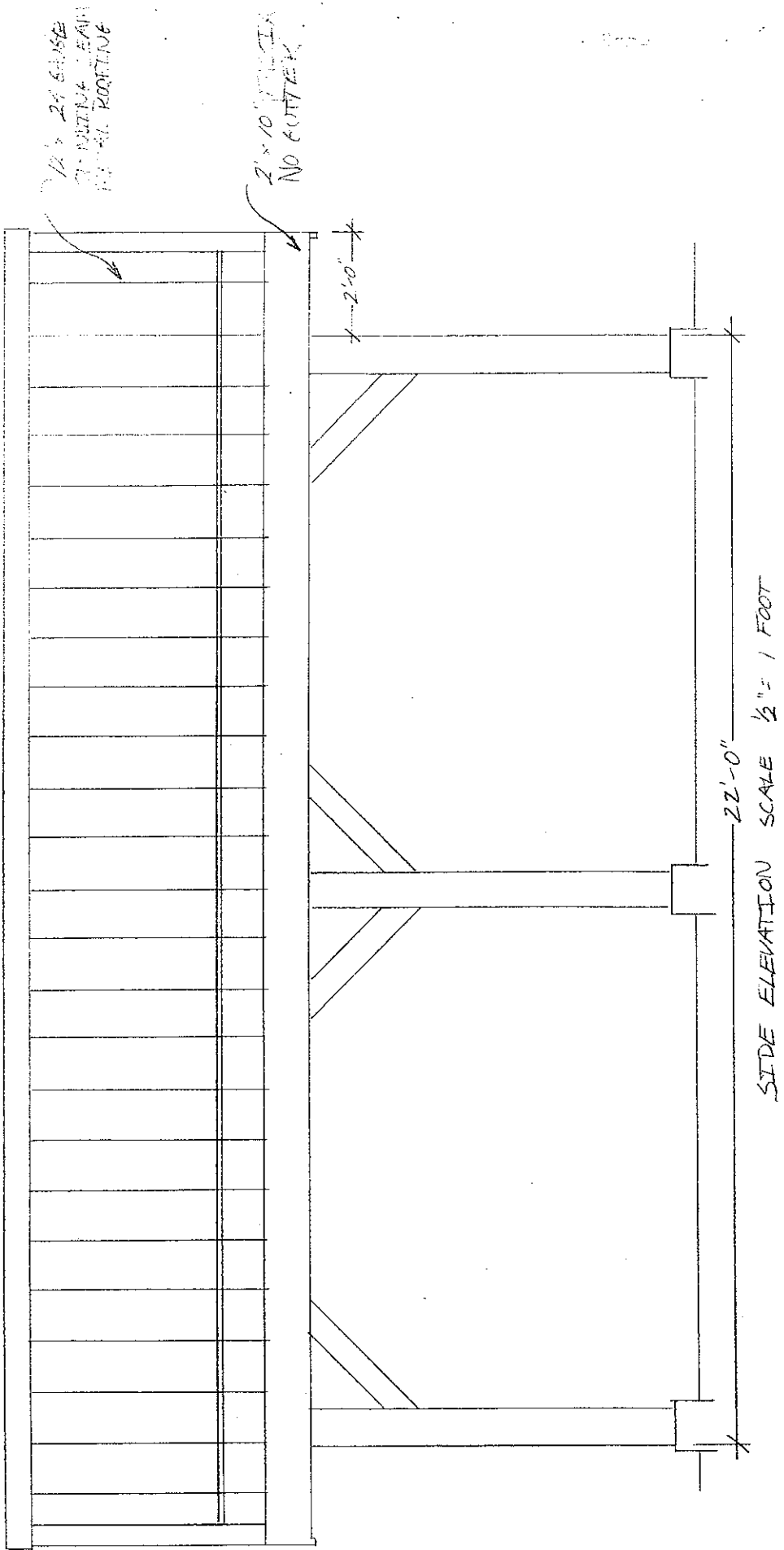

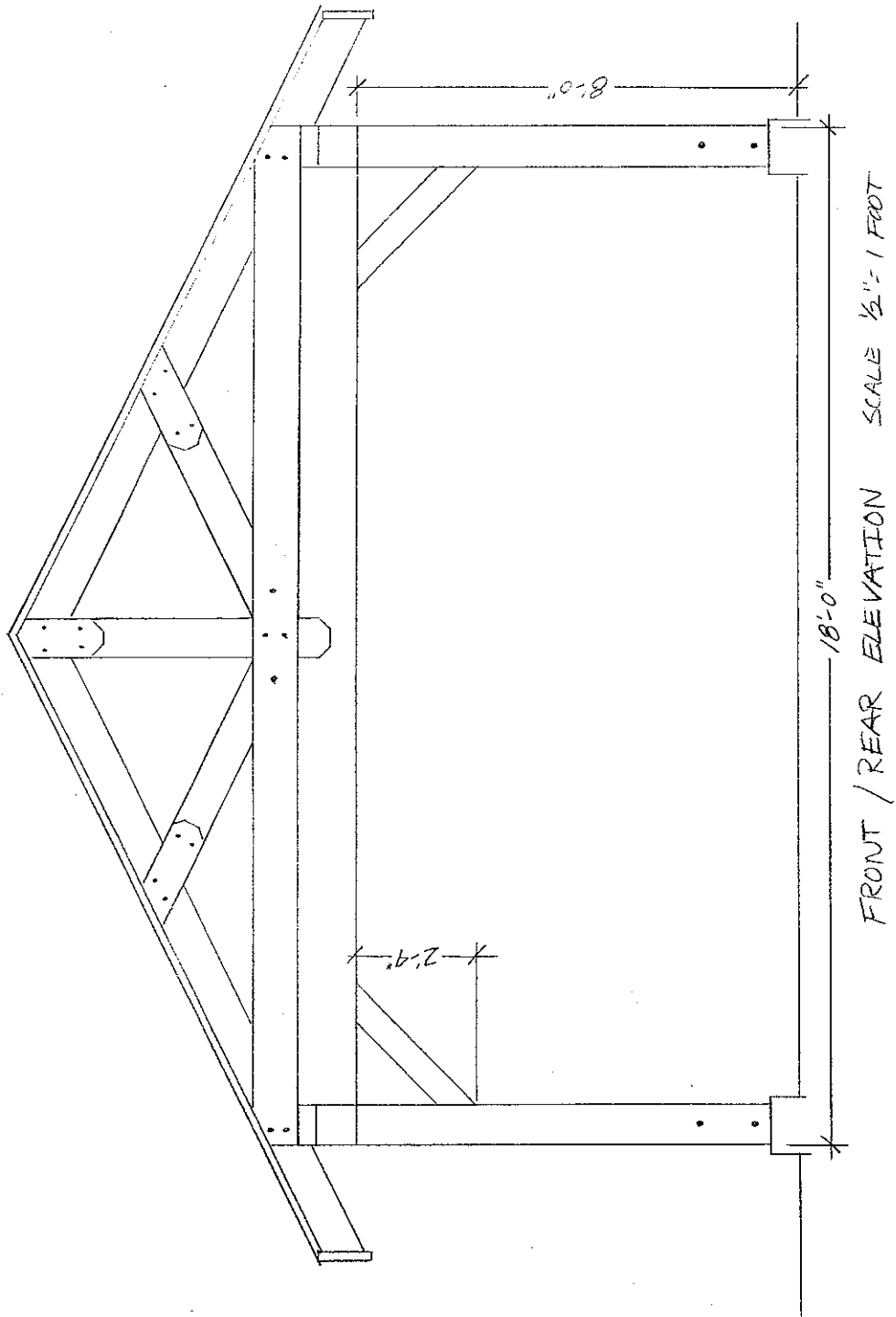

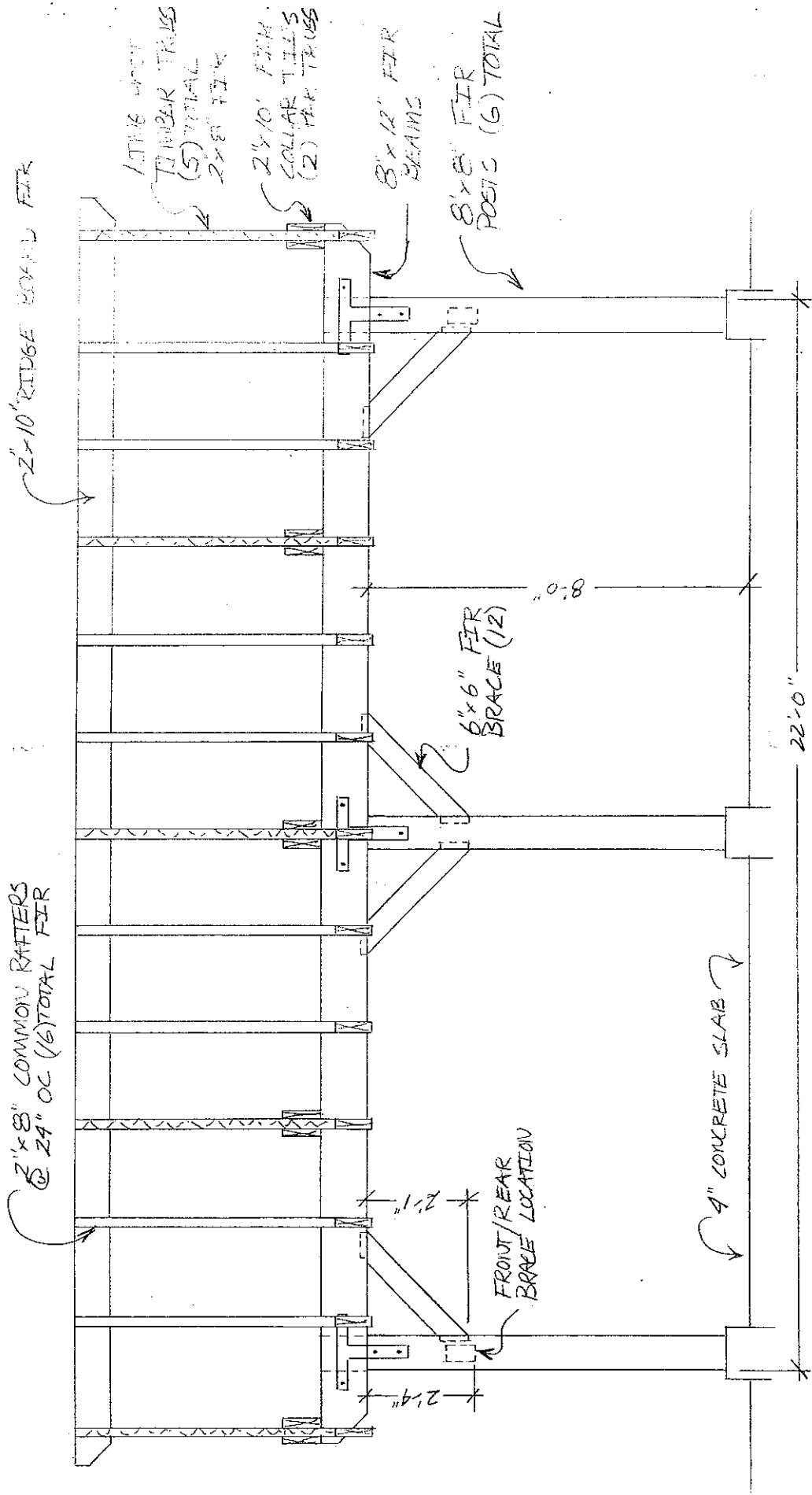

FRAMING DETAIL SCALE 1/2" = 1 FOOT

TIMBER TRUSS DETAIL
SCALE 1/2" = 1 FOOT

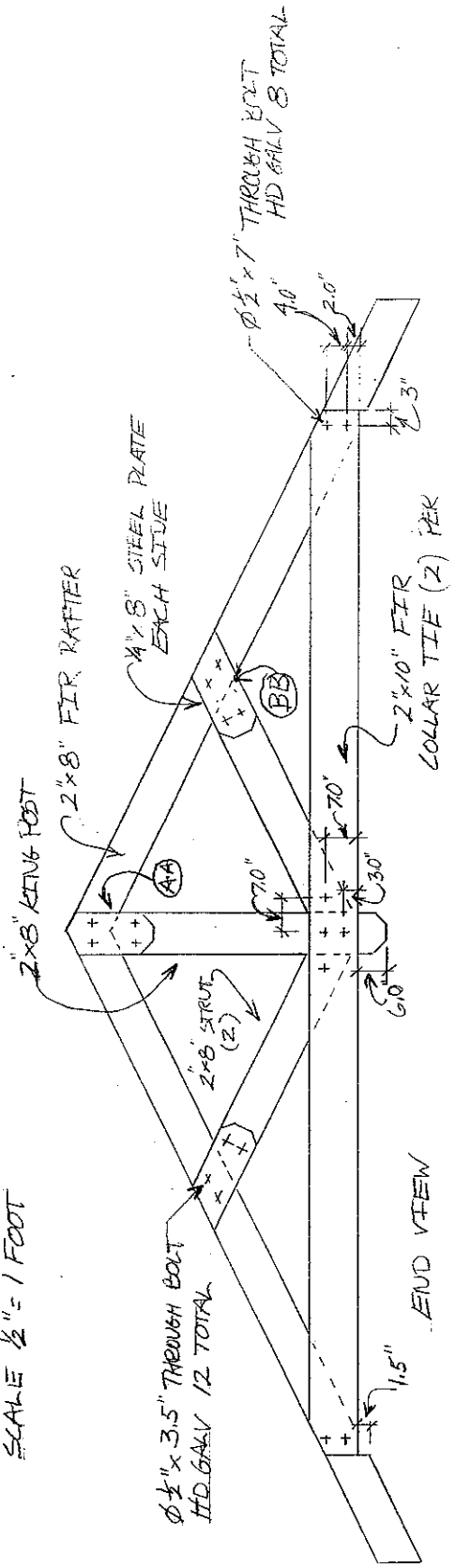

TOP VIEW

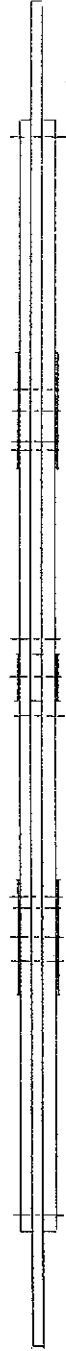

KING POST / STRUT CONNECTION DETAIL
SCALE 2" = 1 FOOT

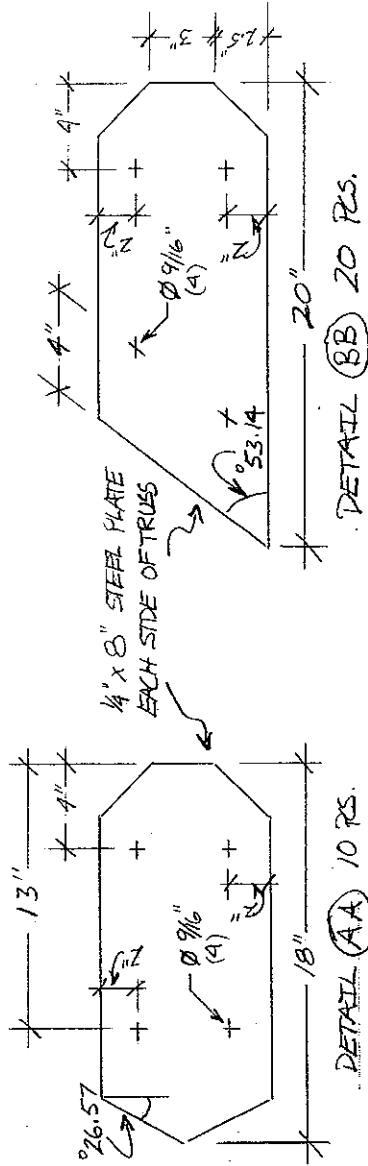

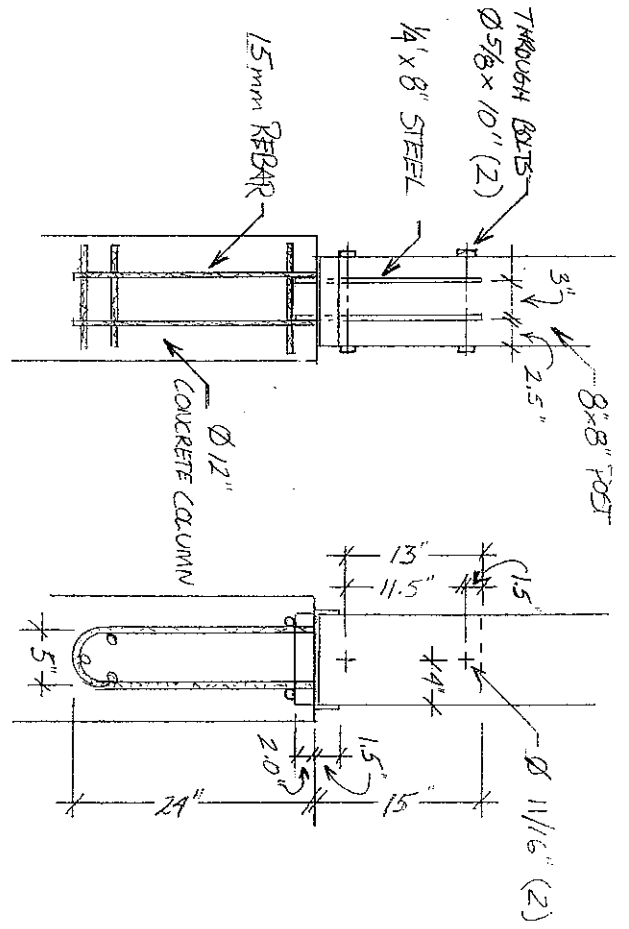
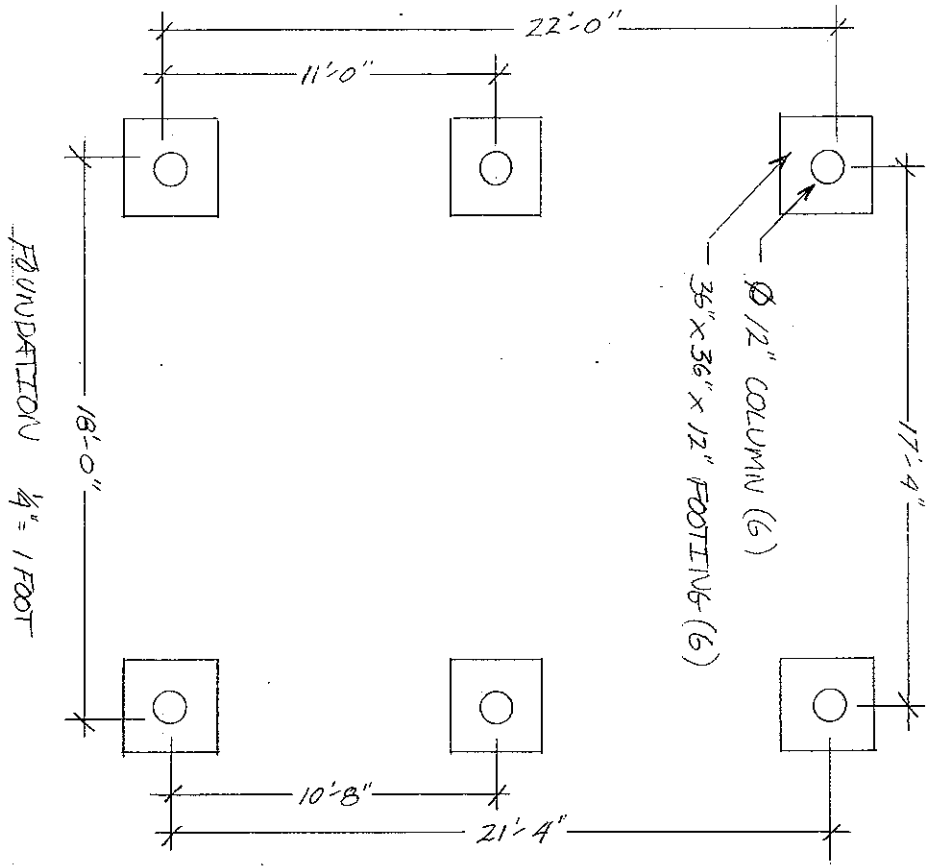

NOTES

FOOTING SIZE TBD. BY ENGINEER
 TO SUIT SOIL BEARING PRESSURE
 CONCRETE COLUMN AND FOOTING
 REINFORCING TBD BY ENGINEER

TIMBER CONNECTION DETAIL (D)
 8" x 8" POST TO 12" CONCRETE COLUMN
 SCALE 1" = 1 FOOT

ROGER STEELE
BOX 503, GOLD RIVER BC
V0P 1G0

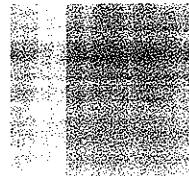

January 25, 2019

Mayor and Council
Gold River BC

Dear Mayor and Council,

It appears I have overstepped my boundaries as president of the Gold River Chamber of Commerce by writing a letter to the Strathcona authorities.

I wish to apologize for this overstep on my part as this letter did not represent the views of the Chamber.

This letter was written by me, and I take full responsibility. It was written due to my frustration at the lack of cell service, as this is a vital part of my business. It appears to me that the large telecommunication companies care nothing for small communities and their residents. I am a firm believer in the old adage that the squeaky wheel gets the grease and therefore we need to be very aggressive when dealing with these multinational telecommunication companies.

Sincerely,

ROGER STEELE

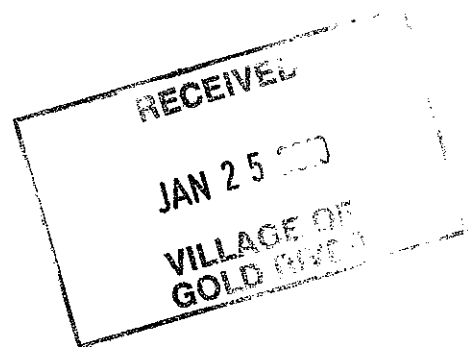



Member of Parliament
North Island-Powell River

January 21, 2019
Ottawa ON

Hon. Bernadette Jordan
Minister of Rural Economic Development
House of Commons
Ottawa, ON K1A 0A6
Via: Internal mail

RE: Continuous cellular coverage

Honorable Minister,

I am writing to express my concerns with the lack of continuous cellular service along Highway 19, connecting several communities in my riding.

The District of Port Hardy, the Sayward Futures Society, Sayward Tourism Committee and many others have contacted this government to request immediate attention to this matter. The inability to communicate along the northern portion of this route is a safety issue for its many commuters.

On January 17, 2018, the Government of Canada and the Government of British Columbia announced a combined investment of \$45.4 million to bring new or improved high-speed Internet to 154 rural and remote communities in British Columbia, including the communities of Tahsis, Tsaxana, Gold River, and Campbell River however nothing was mentioned for the communities of Port Hardy or Sayward.

Federal, provincial, and territorial ministers for economic development agreed to make broadband a priority and establish a long-term strategy to improve access to high-speed Internet services for all Canadians. Among other objectives, Ministers agreed to work towards improving access to the latest mobile wireless services along major roads.

I look forward to your collaboration to ensure that the northern communities in my riding are not forgotten. Please do not hesitate to contact my office should you require additional information.

Yours sincerely,



Rachel Blaney, MP
North Island-Powell River

c.c. communities of Tahsis, Port Hardy, Sayward, Port McNeill, Sayward, Gold River,
Tsaxana

Office
318 Confederation Building
House of Commons
Tel.613.992.2503

Campbell River Office
908 Highway Island
Campbell River, BC V9W 4B2
Toll free: 1 (800) 667.8404

Powell River Office
4697 Marine avenue
Powell River, BC V8A 2L2
Toll free: 1 (800) 667.8404

Rachel.Blaney@parl.gc.ca

