

SUBMITTAL



P.O. BOX 595, TROY, NEW YORK 12181  
TEL 518 274 0961 - FAX 518 274 0210  
[WWW.ROSSVALVE.COM](http://WWW.ROSSVALVE.COM)

## SUBMITTAL

**50RWR- Pilot Operated Pressure  
Relief Valve**

ROSS TECHNOLOGY PARK  
75 102ST STREET, TROY, NY 12181  
TEL 518.274.0961 - [WWW.ROSSVALVE.COM](http://WWW.ROSSVALVE.COM)





SUBMITTAL NOTES

PROJECT: \_\_\_\_\_

Ross Model 50RWR – Pilot Operated Pressure Relief Valve

Size: \_\_\_\_\_ inch / mm

Every Ross Valve shall be hydrostatically tested for body integrity and tight seating at the factory prior to shipment. Field operating conditions are simulated, and the controls are adjusted for proper operation. In order to design and test each valve under operating conditions similar to those in the field, please complete / confirm the following:

- Inlet (supply) pressure \_\_\_\_\_ psi
• Valve relieves to [ ] Atmosphere / Drain [ ] Pump Suction at \_\_\_\_\_ psi

The Ross Globe Body Style Valve can be installed in any position. In order to properly design the valve and orient the controls, please confirm the physical layout of the installation. (\*\* Designates standard valve orientation.)

Valve inlet & outlet (flow) : [ ] Horizontal \*\* or [ ] Vertical
Valve piston axis : [ ] Vertical \*\* or [ ] Horizontal [ ] Horizontal

The valve shall be furnished with:

- ANSI B16.1 Class 250 cast iron body & cap, with: [ ] Class 125 flanges [ ] Class 250 flanges
• Internal metal parts - Bronze construction
• Ross Model 50RWR Hydraulic Pressure Relief Pilot Valve (part #19).
Initial Setting (typically 15-20% above normal inlet pressure): \_\_\_\_\_ psi.
• Ross Model 5F2 Strainer (part #25) with Stainless Steel Filter Element and Blow -Off
• Ross Standard Coarse-Thread Needle Valve (part #17)
• Isolation valves: 0.5" Ball Valves, Bronze/Stainless Steel (part #18)
• Position Indicator, Bronze (part #20)
• Red brass pipe fittings and rigid control piping
• Tapped ports with gauge cocks on inlet & outlet (gauges by others)
• PAINTING: Ferrous surfaces of valve shall be coated with ANSI/NSF Standard 6 1 Certified Epoxy (Tnemec Series N140F)
- Meets the performance requirements of AWWA D102 Inside System No. 1.
• Operation & Maintenance Manual (shipped with the valve).
• [ ] Other (Code / Description) \_\_\_\_\_ / \_\_\_\_\_

(Please list any additional features that are required. A representative may need to contact you for any relevant operating data.)

The valve will be constructed with materials and options stated on this notes page & cut view drawing & quote only, any changes or adders will be reviewed by Ross Valve Mfg. Co., Inc. with possible additional charges to quoted valve pricing. All information following the cut view drawing is for general information. Any special submittal requirements will be an additional charge to purchaser. The Ross Valve Mfg. Co., Inc. reserves the right to modify valve construction which will result in equal or superior performance to existing designs. These modifications may be made at any time and at the sole discretion of the manufacturer.

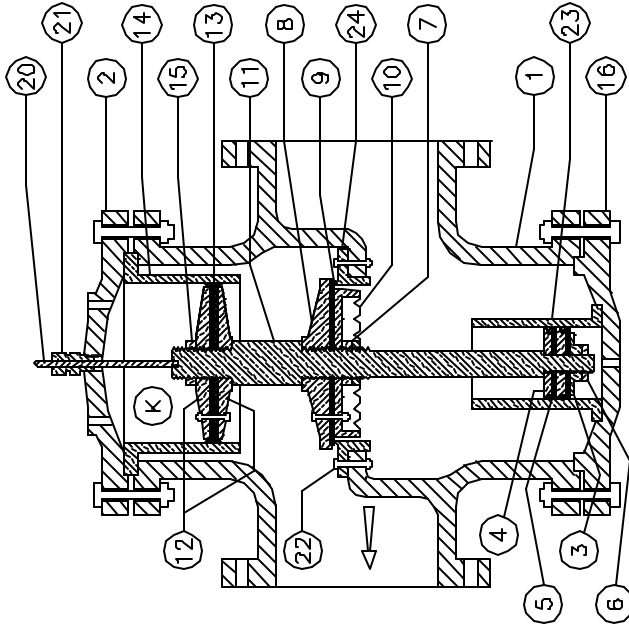
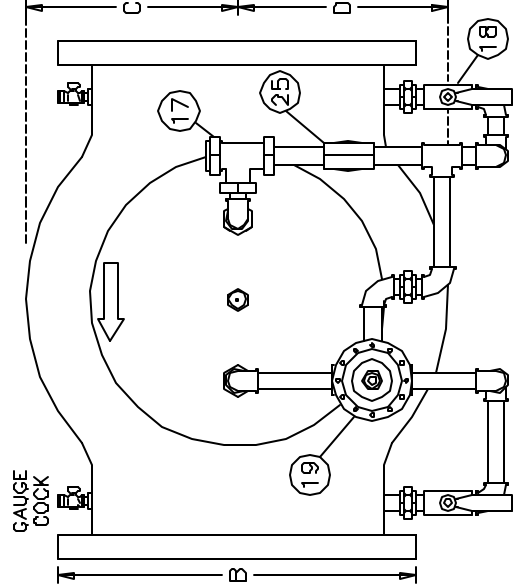
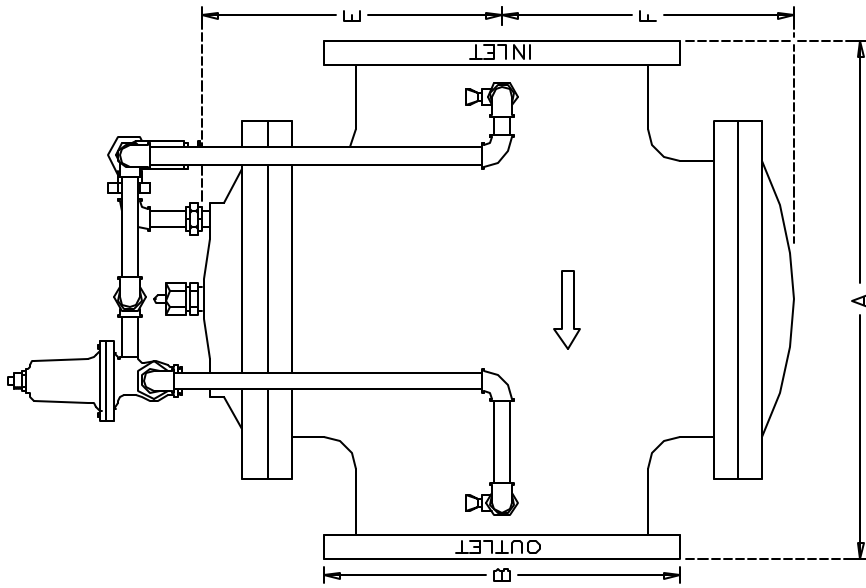

PART	DESCRIPTION	QTY.	MATERIAL
1	VALVE SHELL	1	CAST IRON
2	TOP CAP	1	CAST IRON
3	BOTTOM STEM GUIDE NUT	1	BRONZE
4	BOTTOM CUP FOLLOWERS (SET OF 2)	1	BRONZE
5	PISTON CUP PACKING	2	LEATHER
6	BOTTOM STEM LOCK NUT	1	BRONZE
7	STEM NUT	1	BRONZE
8	SEAT DISC	1	BRONZE
9	SEAT PACKING	1	COMPOSITION
10	SEAT PACKING SUPPORT	1	BRONZE
11	STEM	1	BRONZE
12	MAIN CUP PLATES (SET OF 2)	1	BRONZE
13	MAIN CUP PACKING	2	LEATHER
14	MAIN BUSHING	1	BRONZE
15	TOP STEM NUT	1	BRONZE
16	BOTTOM CAP	1	CAST IRON
17	NEEDLE VALVE	1	BRONZE
18	ISOLATION VALVE	2	BRONZE
19	PILOT - BACK PRESSURE SUSTAINING	1	BRONZE
20	INDICATOR ROD	1	BRONZE
21	INDICATOR STUFFING BOX	1	BRONZE
22	BOLTS & NUTS (SEAT RING)	VARY	BRONZE
23	BOTTOM CAP CYLINDER	1	BRONZE
24	SEAT RING	1	BRONZE
25	STRAINER	1	BRONZE/STAINLESS
	BOLTS & NUTS (TOP & BOTTOM CAP)	VARY	STEEL
	BOLTS & NUTS (CUP PLATES)	VARY	BRONZE
	BOLTS (BOTTOM CAP CYLINDER)	VARY	BRONZE
	INDICATOR ROD PACKING (SET)	1	TEFLON
	COVER & MAIN BUSHING GASKETS	3	COMPOSITION
	STEM GASKETS	3	COMPOSITION

VALVE SIZE (IN)	ASME B.16.1 CLASS	SHIPPING WEIGHT (LBS)	DIMENSIONS (INCHES)				
			A	B	C&D	E	F
2	125	235	14	6	4-3/4	7	7
	250	275	14-5/8	6-1/2	4-3/4	7	7
2.5	125	235	14	7	4-3/4	7	7
	250	275	14-5/8	7-1/2	4-3/4	7	7
3	125	235	14	7-1/2	4-3/4	7	7
	250	275	14-5/8	8-1/4	4-3/4	7	7
4	125	235	14	9	4-3/4	7	7
	250	275	14-5/8	10	4-3/4	7	7
6	125	375	17-3/4	11	6-5/8	9	9
	250	430	17-3/4	12-1/2	6-5/8	9	9
8	125	690	24	13-1/2	8-3/4	12-1/2	12-1/2
	250	750	24-13/16	15	8-3/4	12-1/2	12-1/2
10	125	920	24-7/8	16	10	14-1/4	14-1/4
	250	1000	28-1/4	17-1/2	10	14-1/4	14-1/4
12	125	1375	30	19	12	15-1/2	15-1/2
	250	1475	31-1/2	20-1/2	12	15-1/2	15-1/2
14	125	1770	34-1/4	21	14	18	18
	250	1850	38-3/4	23	14	18	18
16	125	2400	37-7/8	23-1/2	15	21-1/2	21-1/2
	250	2600	39-1/4	25-1/2	15	21-1/2	21-1/2
18	125	3300	41-7/8	25	18-3/8	24	24
	250	3500	41-7/8	28	18-3/8	24	24
20	125	3650	42-3/8	27-1/2	18-3/8	24	24
	250	3800	42-5/8	30-1/2	18-3/8	24	24
24	125	5200	47	32	20	25	25
	250	5500	47	38	20	25	25
30	125	9800	63-3/4	38-3/4	26-1/4	34	34
	250	10600	65-1/16	43	26-1/4	34	34
36	125	11800	85	48	28-1/4	34	34
	250	12800	85	50	28-1/4	34	34

**ROSS VALVE Mfg. Co., Inc.**  
 6 OAKWOOD AVENUE - TROY, NEW YORK, 12180 - TEL. (518) 274 0961  
 POST OFFICE BOX 595 - TROY, NEW YORK, 12181 - FAX (518) 274 0210  
 WEBSITE: www.rossvalve.com - E-MAIL: sales@rossvalve.com

DRAWING 50RWR GLOBE BODY 2" - 36" NO SCALE FIGURE 37  
 DATE 5-22-03 TJS

MODEL 50RWR  
 RELIEF OR BACK PRESSURE SUSTAINING VALVE

THIS PRINT CONTAINS CONFIDENTIAL INFORMATION WHICH IS THE PROPERTY OF ROSS VALVE BY ACCEPTING THIS INFORMATION THE BORROWER AGREES THAT IT WILL NOT BE USED FOR ANY PURPOSE OTHER THAN THAT WHICH IT IS LOANED.  
 NOTE: The Ross Valve Mfg. Co., Inc., reserves the right to modify valve construction which will result in equal or superior performance to existing designs. These modifications may be made at any time and at the sole discretion of the manufacturer.

# DIMENSIONS

## Globe Body Minimum Clearances

## Piston Valve Sizes: 4" - 48"

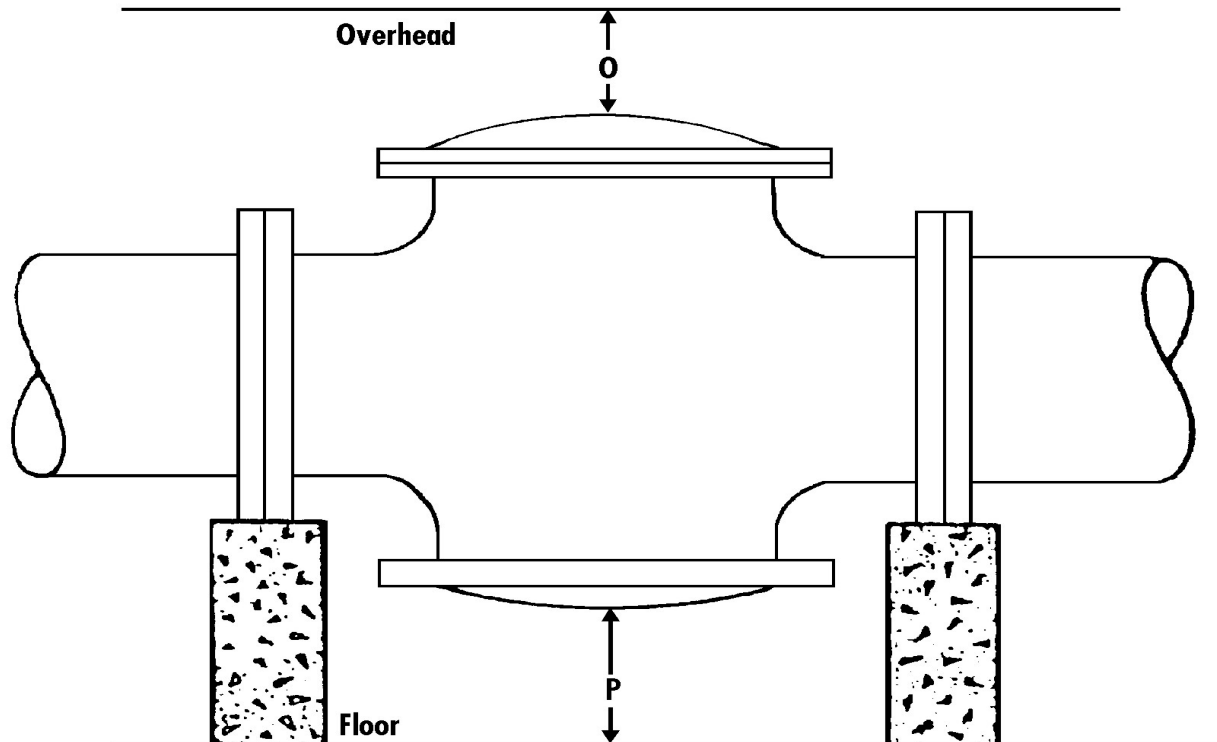

Size (Inches)	4"	6"	8"	10"	12"	14"	16"	18"	20"	24"	30"	36"	42"	48"
<b>O</b>	14	16	18	21	23	28	28	33	33	36	43	46	54	60
<b>P</b>	4 1/2	5 1/2	6 1/2	1	1	1	1	1	1	1	1	1	1	1

### Note

1. Dimension "O" is clearance for removal of the top cap and piston for repacking the main valve. Additional working space for the convenience of the service man should be considered above as well as around the valve.
2. Dimension "P" as listed is the desirable clearance under the valve for removal of the STANDARD bottom cap. This dimension may be reduced to 1 inch for all valves on special applications.

### Note

- A. **Do not obstruct vent hole located at the center of the bottom cap.**
- B. Consideration should be given for installation of valves 14" or larger under manhole in the roof of the valve vault or for additional clearance above the valve since a mechanical hoist will probably be required for removal of the piston. An eye bolt or hook cast in the cover slab over the center of the valve is useful.
- C. If clearance under the valve is limited, dimensions "O" and "P" can be modified. Consult the factory concerning special applications.

VIEW FROM PILOT INLET

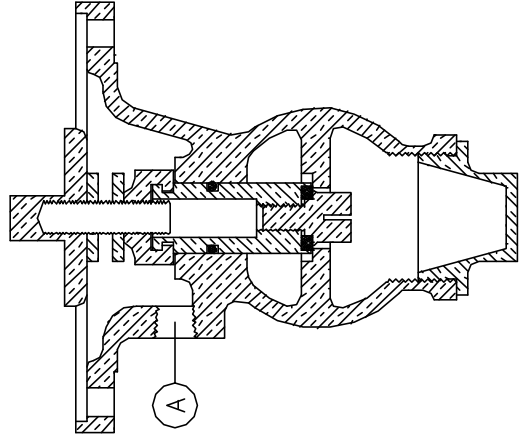

A - STATIC SENSING CONNECTION UNDER DIAPHRAGM TO REMOTE INLET PRESSURE SOURCE

PART	DESCRIPTION	QTY.	MATERIAL
2	ADJUSTING SCREW	1	BRONZE
3	LOCK NUT	1	BRONZE
4	SPRING CHAMBER	1	BRONZE
5	TOP SPRING WASHER	1	BRONZE
6	SPRING(S)	VARY	STEEL
7	BOTTOM SPRING WASHER	1	BRONZE
8	DIAPHRAGM BUTTON	1	BRONZE
*9	DIAPHRAGM(S)	VARY	BRONZE
10	DIAPHRAGM COVER	1	BRONZE
11	BOLT & NUT - DIAPHRAGM COVER	VARY	BRONZE
12	PILOT STEM	1	BRONZE
*13	O-RING - PILOT STEM	1	BUNA-N
14	DIAPHRAGM STEM	1	STAINLESS
15	SHELL	1	BRONZE
16	BOTTOM CAP	1	BRONZE
17	LOCK NUTS - DIAPHRAGM STEM	2	BRONZE
18	LINK NUT	1	BRONZE
*19	SEAT PACKING	1	POLYURETHANE
20	SEAT FOLLOWER & WASHER	1	BRONZE
*22	GASKET - BOTTOM CAP	1	COMPOSITION
*23	GASKET - DIAPHRAGM	1	COMPOSITION

\*INCLUDED IN STANDARD REPAIR KIT

The purpose of a pilot valve is to control the opening and closing of the main valve by trapping or releasing water from the main valve's "operating chamber" ("K" - the chamber above the main valve piston). The **Model 50RWR Relief or Back Pressure Sustaining Pilot Valve** uses this logic in order to control pressure upstream of the main valve.

The pilot valve operates by creating a pressure balance across the diaphragms (#9). Pressure above the diaphragms is set by the adjusting screw (#2) acting on the springs (#6). Pressure beneath the diaphragms is exerted hydraulically via a separate sensing port directly under the diaphragms, from a remote inlet pressure source.

When the pilot valve senses a low inlet pressure, the force of the springs (#6) causes the diaphragms (#9) and entire stem assembly to move down. This pushes the pilot seat packing (#19) into the seat, trapping water in the main valve operating chamber. This causes the piston of the main valve to close, resulting in an increase in the upstream pressure.

Once the upstream pressure rises above the setting of the springs (#6), the hydraulic force overcomes the spring force and the stem assembly is pulled upwards by the attached diaphragms (#9). This causes the pilot seat packing (#19) to come off of its seat, releasing water from the main valve operating chamber. This causes the piston of the main valve to open, resulting in a decrease in the inlet pressure.

This opening and closing sequence (commonly referred to as "throttling") is continuously taking place in order to control the inlet pressure of the main valve.

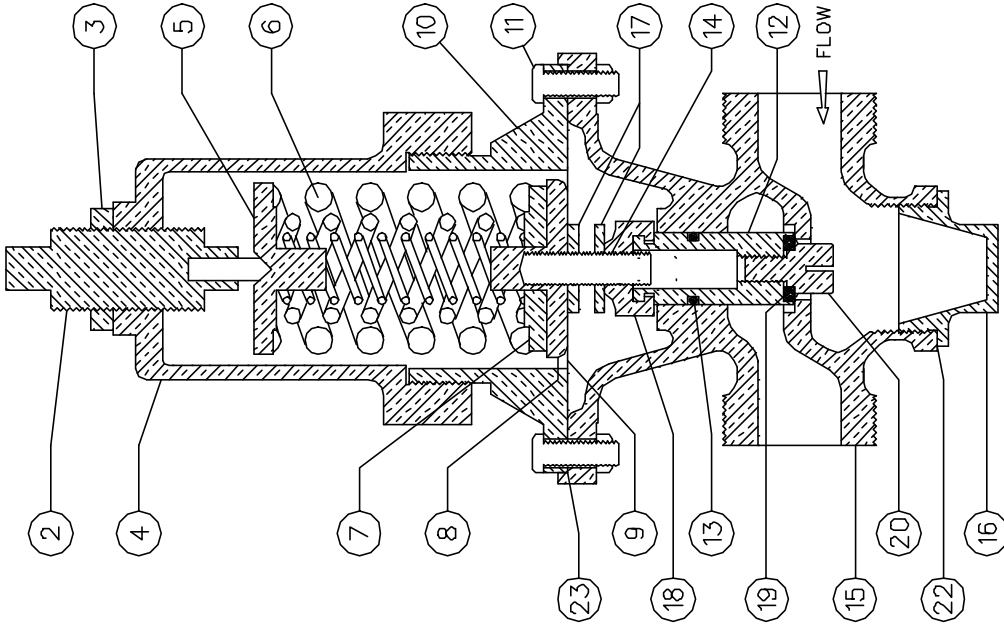

FILE: P50RWR	
<b>ROSS VALVE Mfg. Co., Inc.</b>	
6 DAKWOOD AVENUE - P.O. BOX 595 - TROY, NEW YORK, 12181 - TEL. (518) 274-0961	
NO SCALE	DRAWING 50RWR PILOT
DATE 10-1-81	REVISED 6-30-99 S.M
MODEL 50RWR PILOT VALVE RELIEF OR BACK PRESSURE SUSTAINING	

# STRAINER

Model Number: 5F-2

**Sizes:** ½" – 1"

**Located:** On any external piping

**Purpose:** To protect external piping and control devices from fouling or damage from foreign particles

**Screen:** Cylindrical Dutch weave stainless steel wire mesh

**Piping Connection:** Standard pipe thread

## Operation

1. Water enters the cylindrical screen (#2) from the top and passes out through the sides of the cylinder.
2. Any particle too large to pass through .012 inch openings gets trapped in the cylinder, where, unless there is unusual turbulence, they settle at the bottom.

## Recommendation

1. Strainer should be "blown down" frequently to remove collected foreign material from the sediment chamber.
2. Strainer screen should be removed occasionally for inspection and thorough cleaning.

## Note

1. To clean without shutting down the line, open the flush cock (#5) in the bottom cap (#4) for several seconds.
2. To remove the screen (#2), which requires shutting down the line, unscrew the bottom cap assembly (#5).

## Option

Two strainers installed in parallel (with the appropriate isolation valves) to permit uninterrupted service while cleaning.

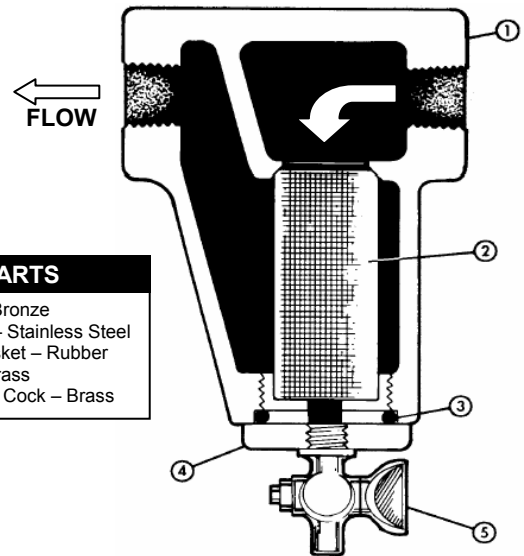

### PARTS

1. Body – Bronze
2. Screen – Stainless Steel
3. Cap Gasket – Rubber
4. Cap – Brass
5. Flushing Cock – Brass

# NEEDLE VALVE

**Sizes:** One size fits all piston valves

**Primarily Controlled By:** Manually Adjusted

**Located:** On external control circuit of the main valve

**Purpose:** To limit flow in and out of the operating chamber

**Standard Shipped Adjustment:**

**Course Needle:** 5/6 to 2 turns off the seat

**Fine Needle:** Based on individual specifications

## Operation

The simple construction reliably limits maximum flow through the external piping, depending on the position of the adjustable stem/needle (#4) relative to the seat.

1. When the needle (#4) is adjusted counter-clockwise to a raised position,
  - a. More water can pass through the needle valve.
  - b. Water enters (leaves) the operating chamber more quickly.
  - c. The main valve piston moves up and down more quickly.
2. When the needle (#4) is adjusted clockwise to a lowered position,
  - a. Less water can pass through the needle valve.
  - b. Water enters (leaves) the operating chamber more slowly.
  - c. The main valve piston moves up and down more slowly.

## Adjustment

To adjust needle valve, which can be done without shutting down the main valve:

1. Remove the hex cap (#2) and lock (#1).
2. With a screw driver;
  - a. Turn the needle (#4) counter-clockwise to raise it
  - b. Turn the needle (#4) clockwise to lower it
3. Once the optimum position is determined, no further adjustment of the needle should be required.

## Note

It is advisable to occasionally remove the cap (#2) and lock (#1) and change the position of the needle (#4) momentarily to insure against gradual plugging.

## Option

Two separate needle valves on one main valve – Provides independent control of opening and closing speeds.

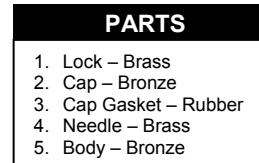

### PARTS

1. Lock – Brass
2. Cap – Bronze
3. Cap Gasket – Rubber
4. Needle – Brass
5. Body – Bronze

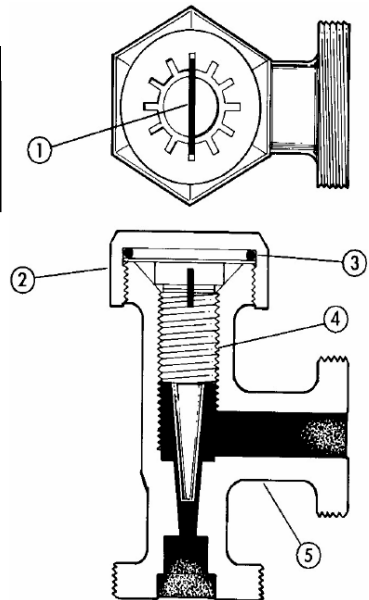

# (Factory Accelerated) Pota-Pox™ Plus

## SERIES N140F

### PRODUCT PROFILE

GENERIC DESCRIPTION	Polyamidoamine Epoxy
COMMON USAGE	Innovative potable water coating which offers high-build edge protection and allows for application at a wide range of temperatures (down to 35°F or 2°C). For use on the interior and exterior of steel or concrete tanks, reservoirs, pipes, valves, pumps and equipment in potable water service.
COLORS	F1211 Fast Cure Red, F1255 Fast Cure Beige, 11WH Fast Cure White, 15BL Fast Cure Tank White, 39BL Fast Cure Delft Blue, 35GR Fast Cure Black. <b>Note:</b> Epoxies chalk with extended exposure to sunlight. Lack of ventilation, incomplete mixing, miscatalyzation or the use of heaters that emit carbon dioxide and carbon monoxide during application and initial stages of curing may cause yellowing to occur.
SPECIAL QUALIFICATIONS	Certified by <b>NSF International</b> in accordance with <b>ANSI/NSF Std. 61</b> . Ambient air cured Series N140F is qualified for use on tanks and reservoirs of 1,000 gallons (3,785L) capacity or greater, pipes ten (10) inches (25 cm) in diameter or greater and valves two (2) inches (5 cm) in diameter or greater. Conforms to <b>AWWA D 102 Inside Systems No. 1 and No. 2</b> . Contact your Tnemec representative for systems and additional information.
PERFORMANCE CRITERIA	Extensive test data available. Contact your Tnemec representative for specific test results.



### COATING SYSTEM

PRIMERS	Self-priming, 20, FC20, 91-H2O
TOPCOATS	<b>Interior:</b> Series N140F <b>Exterior:</b> Series 27, 66, N69, 73, N140, 161, 175, 180, 700, 1074, 1075. Refer to COLORS on applicable topcoat data sheets for additional information. <b>Note:</b> When topcoating with Series 700, an intermediate coat of Series 73 or 1075 is required. <b>Note:</b> The following maximum recoat time applies when using Endura-Shield topcoats: Series 73, 175, 1074 or 1075, sixty (60) days. If this time limit is exceeded, Series N140F must be uniformly scarified or recoated with itself prior to applying Endura-Shield. When topcoating with Series 180, the N140F maximum recoat time is 90 days.

### SURFACE PREPARATION

STEEL	<b>Immersion Service:</b> SSPC-SP10/NACE 2 Near-White Blast Cleaning <b>Non-Immersion Service:</b> SSPC-SP6/NACE 3 Commercial Blast Cleaning
PRIMED STEEL	<b>Immersion Service:</b> Scarify the Series N140F, 20 or FC20 prime coat surface by abrasive-blasting with fine abrasive before topcoating if it has been exterior exposed for 60 days or longer and N140F is the specified topcoat.
CAST/DUCTILE IRON	Contact Tnemec Technical Services.
CONCRETE	Allow new concrete to cure 28 days. For optimum results and/or immersion service, abrasive blast referencing SSPC-SP13/NACE 6 Surface Preparation of Concrete and Tnemec's Surface Preparation and Application Guide. Fill all holes, pits, voids and cracks with 63-1500 Filler and Surfacers.
ALL SURFACES	Must be clean, dry and free of oil, grease and other contaminants.

### TECHNICAL DATA

VOLUME SOLIDS*	68.0 ± 2.0% (mixed)
RECOMMENDED DFT	3.0 to 8.0 mils (75 to 205 microns) per coat. <b>Note: Number of coats and thickness requirements will vary with substrate, application method and exposure. Contact your Tnemec representative.</b>

CURING TIME AT 5 MILS DFT

Temperature	To Handle	To Recoat	Immersion
75°F (24°C)	4 hours	5 hours	7 days
65°F (18°C)	7-8 hours	9-11 hours	8 days
55°F (13°C)	12-14 hours	16-20 hours	9-10 days
45°F (7°C)	18-22 hours	28-32 hours	12-13 days
35°F (2°C)	28-32 hours	46-50 hours	16-18 days

Curing time varies with surface temperature, air movement, humidity and film thickness. **Note:** For valve applications allow 14 days cure at 75°F (24°C) prior to immersion. For pipe applications allow 30 days cure at 75°F (24°C) prior to immersion.

VOLATILE ORGANIC COMPOUNDS*	<b>Unthinned</b> 2.29 lbs/gallon (274 grams/litre)	<b>Thinned 10%</b> 2.71 lbs/gallon (324 grams/litre)
THEORETICAL COVERAGE*	1,094 mil sq ft/gal (26.8 m <sup>2</sup> /L at 25 microns). See APPLICATION for coverage rates.	
NUMBER OF COMPONENTS	Two: Part A and Part B	
PACKAGING	5 gallon (18.9L) pails and 1 gallon (3.79L) cans — Order in multiples of 2.	
NET WEIGHT PER GALLON*	13.45 ± 0.25 lbs (6.10 ± .11 kg) (mixed)	
STORAGE TEMPERATURE	Minimum 20°F (-7°C)	Maximum 110°F (43°C)
TEMPERATURE RESISTANCE	(Dry) Continuous 250°F (121°C)      Intermittent 275°F (135°C)	

Published technical data and instructions are subject to change without notice. The online catalog at [www.tnemec.com](http://www.tnemec.com) should be referenced for the most current technical data and instructions or you may contact your Tnemec representative for current technical data and instructions.  
© March 2004, by Tnemec Company, Inc.

**TECHNICAL DATA continued**

**SHELF LIFE** 24 months at recommended storage temperature.  
**FLASH POINT - SETA** Part A: 82°F (28°C) Part B: 80°F (27°C)  
**HEALTH & SAFETY** Paint products contain chemical ingredients which are considered hazardous. Read container label warning and Material Safety Data Sheet for important health and safety information prior to the use of this product. **Keep out of the reach of children.**

**APPLICATION**

**COVERAGE RATES\***

	Primer			Intermediate / Topcoat		
	Dry Mills (Microns)	Wet Mills (Microns)	Sq Ft/Gal (m <sup>2</sup> /Gal)	Dry Mills (Microns)	Wet Mills (Microns)	Sq Ft/Gal (m <sup>2</sup> /Gal)
Suggested (1)	4.0 (100)	6.0 (150)	273 (25.4)	5.0 (125)	7.5 (190)	218 (20.3)
Minimum	3.0 (75)	4.5 (115)	364 (33.9)	4.0 (100)	6.0 (150)	273 (25.4)
Maximum	5.0 (125)	7.5 (190)	218 (20.3)	6.0 (150)	9.0 (230)	182 (17.0)

**(1) Note:** Roller or brush application requires two or more coats to obtain recommended film thickness. Series N140F can be spray applied to an optional high-build film thickness range of 6.0 to 8.0 dry mils (150 to 205 dry microns) or 8.5 to 11.5 wet mils (215 to 290 wet microns). Allow for overspray and surface irregularities. Film thickness is rounded to the nearest 0.5 mil or 5 microns. Application of coating below minimum or above maximum recommended dry film thicknesses may adversely affect coating performance.

**MIXING**

1. Start with equal amounts of both Parts A & B.
2. Using a power mixer, separately stir Parts A & B.
3. Add Part A to Part B under agitation, stir until thoroughly mixed.
4. Both components should be above 50°F (10°C) prior to mixing. For application to surfaces between 35°F to 50°F (2°C to 10°C), allow mixed material to stand thirty (30) minutes and restir before using. For optimum application properties, blended components should be above 40°F (4°C).

**POT LIFE**

4 hours at 35°F (2°C)                      2 hours at 77°F (25°C)                      1 hour at 100°F (38°C)

**THINNING**

Use No. 4 Thinner. For air spray, thin up to 10% or ¾ pint (380 mL) per gallon. For airless spray, roller or brush, thin up to 5% or ¼ pint (190 mL) per gallon. **Caution:** Series N140F NSF certification is based on thinning with No. 4 Thinner. Use of any other thinner voids ANSI/NSF Std. 61 certification.

**SURFACE TEMPERATURE**

Minimum 35°F (2°C)                      Maximum 135°F (57°C)  
 The surface should be dry and at least 5°F (3°C) above the dew point. Coating won't cure below minimum surface temperature.

**APPLICATION EQUIPMENT**

**Air Spray**

Gun	Fluid Tip	Air Cap	Air Hose ID	Mat'l Hose ID	Atomizing Pressure	Pot Pressure
DeVilbiss MBC or JGA	E	765 or 78	5/16" or 3/8" (7.9 or 9.5 mm)	3/8" or 1/2" (9.5 or 12.7 mm)	75-100 psi (5.2-6.9 bar)	10-20 psi (0.7-1.4 bar)

Low temperatures or longer hoses require higher pot pressure.

**Airless Spray**

Tip Orifice	Atomizing Pressure	Mat'l Hose ID	Manifold Filter
0.015"-0.019" (380-485 microns)	1800-3000 psi (124-207 bar)	1/4" or 3/8" (6.4 or 9.5 mm)	60 mesh (250 microns)

Use appropriate tip/atomizing pressure for equipment, applicator technique and weather conditions.  
**Note:** Application over inorganic zinc-rich primers: Apply a wet mist coat and allow tiny bubbles to form. When bubbles disappear in 1 to 2 minutes, apply a full wet coat at specified mil thickness.  
**Roller:** Roller application optional when environmental restrictions do not allow spraying. Use 3/8" or 1/2" (9.5 mm or 12.7 mm) synthetic nap covers.  
**Brush:** Recommended for small areas only. Use high quality natural or synthetic bristle brushes.

**CLEANUP**

Flush and clean all equipment immediately after use with the recommended thinner or MEK.

\*Values may vary with color.

WARRANTY & LIMITATION OF SELLER'S LIABILITY: Tnemec Company, Inc. warrants only that its coatings represented herein meet the formulation standards of Tnemec Company, Inc. THE WARRANTY DESCRIBED IN THE ABOVE PARAGRAPH SHALL BE IN LIEU OF ANY OTHER WARRANTY, EXPRESSED OR IMPLIED, INCLUDING BUT NOT LIMITED TO, ANY IMPLIED WARRANTY OF MERCHANTABILITY OR FITNESS FOR A PARTICULAR PURPOSE. THERE ARE NO WARRANTIES THAT EXTEND BEYOND THE DESCRIPTION ON THE FACE HEREOF. The buyer's sole and exclusive remedy against Tnemec Company, Inc. shall be for replacement of the product in the event a defective condition of the product should be found to exist and the exclusive remedy shall not have failed its essential purpose as long as Tnemec is willing to provide comparable replacement product to the buyer. NO OTHER REMEDY (INCLUDING, BUT NOT LIMITED TO, INCIDENTAL OR CONSEQUENTIAL DAMAGES FOR LOST PROFITS, LOST SALES, INJURY TO PERSON OR PROPERTY, ENVIRONMENTAL INJURIES OR ANY OTHER INCIDENTAL OR CONSEQUENTIAL LOSS) SHALL BE AVAILABLE TO THE BUYER. Technical and application information herein is provided for the purpose of establishing a general profile of the coating and proper coating application procedures. Test performance results were obtained in a controlled environment and Tnemec Company makes no claim that these tests or any other tests, accurately represent all environments. As application, environmental and design factors can vary significantly, due care should be exercised in the selection and use of the coating. **FOR INDUSTRIAL USE ONLY.**



# ROSS VALVE SUPPORT SERVICES

PROVIDES PERSONAL SERVICE IN EVERY PHASE OF DEVELOPMENT,  
INSTALLATION AND MAINTENANCE.

We are always available to provide answers to any questions. No sale is ever "final"



## DEDICATED SUPPORT LINES

Sales engineers available Monday through Friday 7am to 5:00pm EST

Phone to help with any questions — (518) 274-0961

Fax machine – (518) 274-0210

After Hours Support – (518) 279-4373

E-Mail – sales@rossvalve.com



## TRAINING

Factory Training — Ross Valve believes that our customers should know as much as possible about our products. That is why we periodically host Customer Training seminars at our Ross Technology Park in Troy, NY. Here, our customers learn the workings of the valves, how to correctly maintain them, and how they are manufactured.

In addition, Ross representatives are often in the field giving product seminars for your convenience.

## FIELD SERVICE

When a repair, upgrade, or modification is required for an existing Ross Valve, Factory Authorized Ross Service Technicians offer the best service available, including:

Technical assistance for start-up or continuing training.

Fully inventoried service vehicles to allow replacement of necessary parts.

Confined Space/OSHA trained with latest equipment

On-site / hands-on training for your staff.

Ability to return older valves to "like-new" condition.

## YEARLY CONTRACTS AVAILABLE

## WARRANTY

All valves and materials are guaranteed free from defects for 1 year from the date shipped.

Ross Valves are economically rebuilt. Every internal part is replaceable through the top of the valve, without removing it from the line. All seals and internal packings are replaceable, which contributes to the valve's longevity.

Ross Valve stocks a wide variety of repair parts which can be received by the customer as early as the next day. In-house computer links track packages to ensure timely delivery.

Detailed historical record keeping gives us a full report of all maintenance or upgrades that have been made on each valve. This allows us to evaluate performance in the past and maximize performance in the future.



# ROSS VALVE

Automatic Control Valves & Pre-Packaged  
Vaults for Water & Wastewater

[www.rossvalve.com](http://www.rossvalve.com)

P.O. Box 595,

Troy, New York 12181, USA

Phone: (518) 274-0961 Fax: (518) 274-0210

E-Mail: sales@rossvalve.com