

The Real McCoy  
**SOM SSB TRANSMITTER**  
 HOME BREWED BY KG7TR

Sheet 1 of 2  
 TRANSMITTER  
 CIRCUITS  
 2 MAR 2019

See sheet 2 for notes.

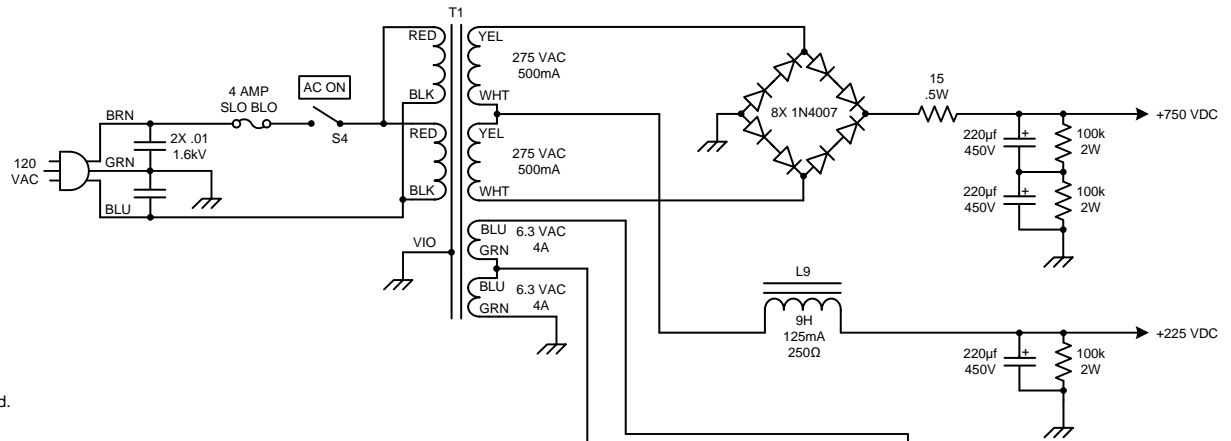

**NOTES:**

1. Relays shown in deenergized (receive) position.
2. Text boxes identify front or rear panel controls.
3. Asterisks identify silver mica capacitors.
4. All fixed resistors are .25 watt, 5% unless otherwise noted.
5. Capacitors with no decimal point are in pf, except for electrolytics/tantalum, which are in µf.
6. Capacitors with decimal point are in µf.

