

## Hampden SIM-200 Virtual Controls

### Purpose

The **Model SIM-200** Virtual AC/DC Controls computer program allows students to develop typical motor control and electrical generation experiments on their computer with “drag and drop” component placement.

### Recommended Equipment

The **MODEL SIM-200** will run on any Windows XP-based PC with 256Mb RAM.

Requires 20Mb of Hard Drive space, and is best viewed on a 17" monitor (800/600 resolution).

### Description

An essential line-up of Hampden Series 100 Motors, Machines, Loads, & Controls are computer modeled, allowing unlimited flexibility for students.

In a typical session, a student selects the required components, assembles them on the computer screen's workbench and makes connections to virtual power supplies and meters of all ranges and inputs—allowing complete analysis of relevant signals.

Analysis software tools are provided for graphing, such as V-Curves, Torque curves, etc. Real-world replication is stressed by using full-color renditions of the Hampden Series 100 Fractional Horsepower AC and DC Motors and Machines, ACC-100 AC Controls, DCC-100 DC Controls, and emphasizing connections to all appropriate terminals.

### Software

The Hampden **MODEL SIM-200** allows the students to explore motor control and troubleshooting, with interactive prompting on the computer screen.

The provided lesson plan consists of 20 preprogrammed experiments. If incorrect steps are performed, a help screen pops up to immediately help the student understand and make the needed corrections.

The software includes an instructor's set-up program complete with password.

Instructor access to student progress reports and quick quiz results are password protected under the program maintenance menu. Optional network setup centralizes instructor database information.



The Hampden SIM-200 Virtual Motors and Machines Software provides a “Virtual Workbench,” allowing students to assemble, test and analyze a large range of equipment.

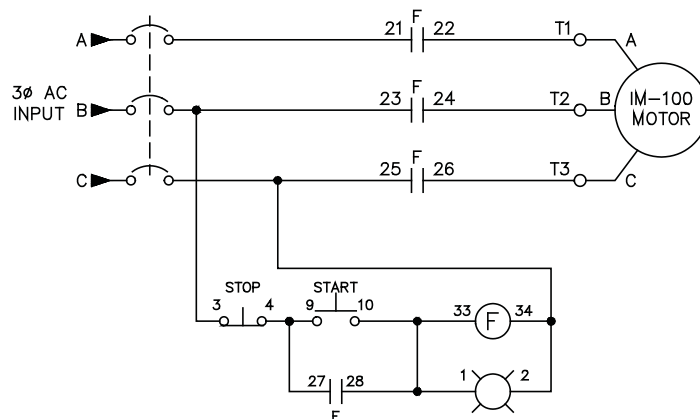

IM-100 Diagram

All Hampden units are available for operation at any voltage or frequency.

**Hampden**  
ENGINEERING CORPORATION