

WARNINGS

Tension Leg Chains Must Be Set To Correct Lengths

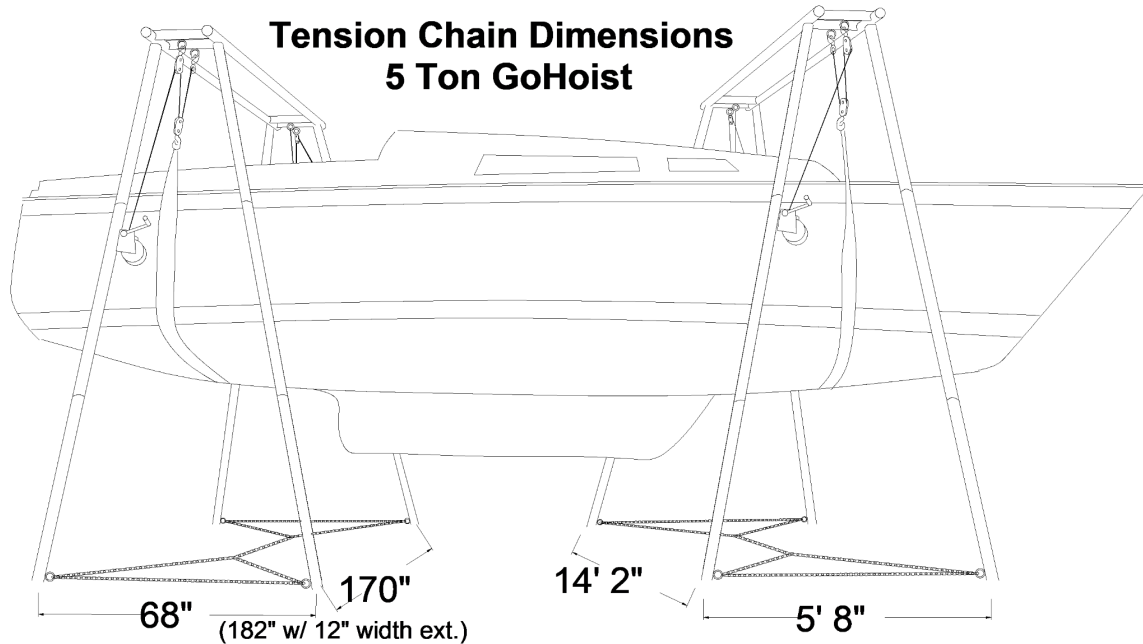

Oil All Rigging Pulley Blocks Before Every Lift

Check that all pulley wheels turn freely.

Frozen/locked pulley wheels will wear and break cables.

Use any chain, motor or heavy oil.

Purchase new pulley blocks at www.GoHoist.com

FIG. 3

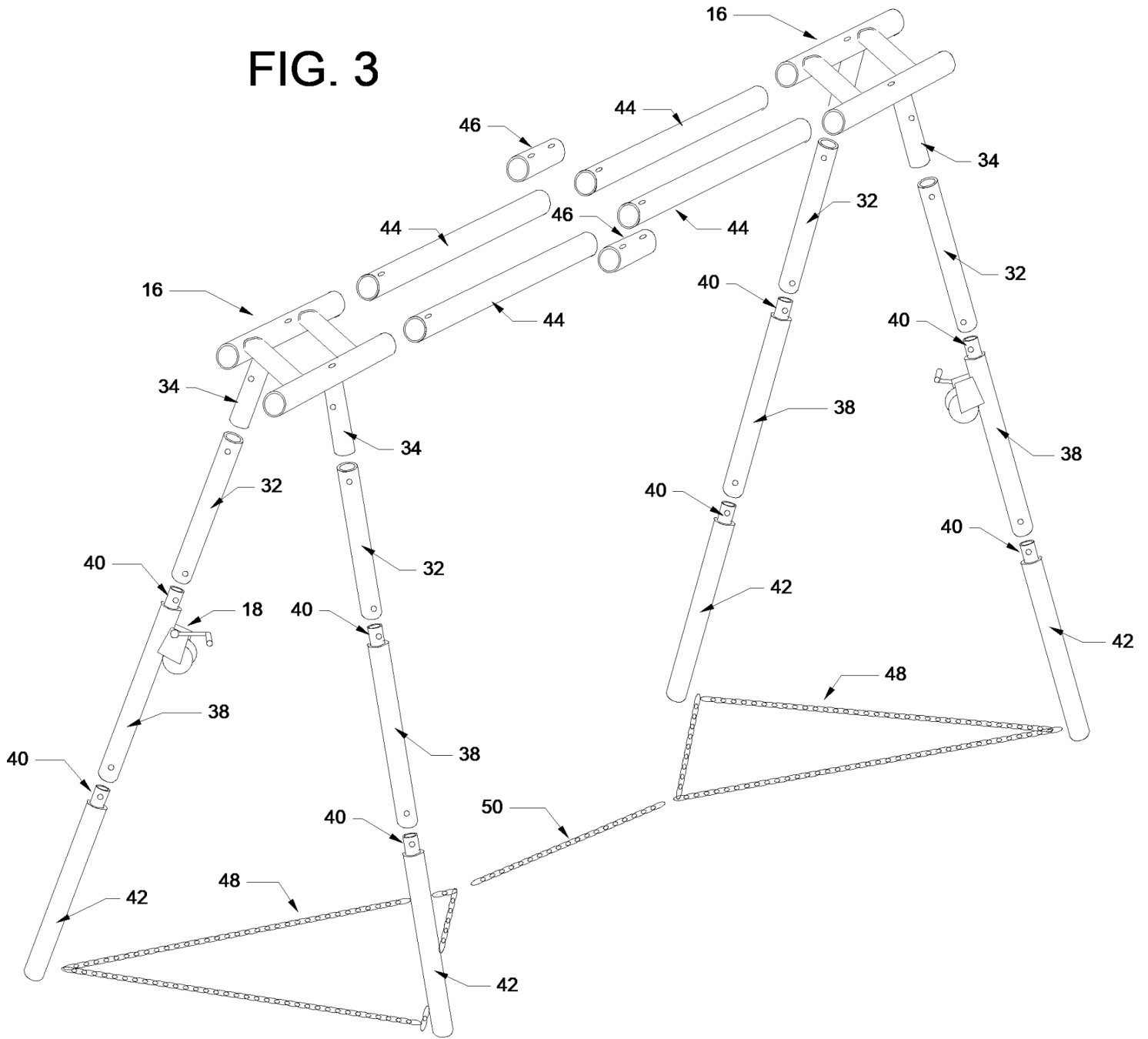

- | | | |
|------------------------------------|-------------------------|-------------------------|
| 16 - Shoulder Section | 32 - Top Leg Section | 36 - Middle leg Section |
| 38 - Middle Leg Section with Winch | 42 - Bottom Leg Section | 44 - Cross Beam |
| 46 - Cross Beam Sleeve | 48 - Tension Chain | |

Assembly Instructions for 5 ton and 3 ton GoHoist Lite Units

Step 1. Place two shoulder sections approximately 8 feet apart. Make sure that GoHoist decals are facing outwards.

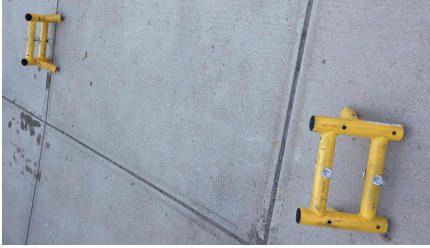

Step 2. Insert two aluminum cross brace sections into the inside slots on shoulder sections, lining up pin holes and placing locking pins in both holes.



Step 3. Insert two more aluminum cross sections into the opposing shoulder section. Next join the middle of the cross sections with the 9" red sleeves using locking pins



Insert locking pins with bend up, once in rotate down. To remove rotate bend up and pull out



Step 4. Now lift one end of the cross brace assembly and insert the red top leg sections, lining up the pinholes and inserting pins.



Step 5. Insert the red top leg sections on the opposite side of the cross brace assembly.



Step 6. The middle leg sections are next. The right side section will have a winch, make sure the winch handle is facing out and the winch drum is on the inside.



Step 7. Insert the middle way sections on the opposite side, once again the winch section going on the right with the handle facing out. Making sure you insert locking pins in each section.

Step 8. Unwind the winch giving you slack on the snatch blocks and end hook. Attach the end hook onto the internal eyebolt on the shoulder, then attach the internal snatch block hook onto the external eyebolt on the shoulder unit. Do this for both winches on each end.

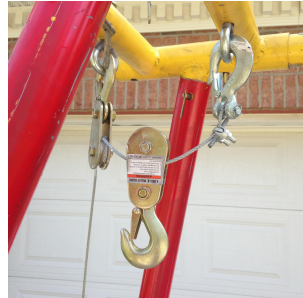

Step 9. Now insert the bottom leg segments making sure that the eyebolts on the bottom are facing inward so that tension chains can be attached. For this step two people are needed, one to hold the unit up, the other to insert the bottom leg segments. Note there are no locking pins for the bottom leg sections.

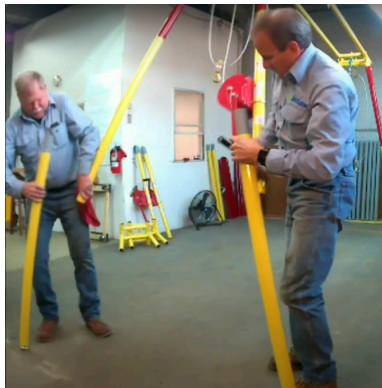

Step 10. The unit is now assembled and is ready to attach the tension chain between the four legs.



The two chain loops, now attached to the legs, pull the middle chain sections towards each other and attach the third chain segment, using the hook on one loop and hook on the middle chain as shown.

Step 11. Last step is to attach a lifting strap to both winch hooks, with the straps under the boat hull. The lifting strap may need shortening to fit shallower hulls. Shorten the strap by adding a simple loop knot at one end of the strap and place the knotted loop end on the winch hook. Do not cut the lifting straps.

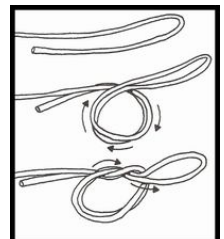

For newest GoHoist manuals and how-to videos go to www.gohoist.com

Using the Tension Chains

Tension chains must be attached to the bottom of each leg of the lifting hoist. The tension chains should have no slack and have a 5' 2" distance between each right and left foot. The tension chains between the port and starboard side hoist should be connected also. Do not lift without tension chains properly secured to each foot of the lifting hoist.

Tension chains are critical so that the legs do not slip and spread out causing failure of the lifting hoist. Do not use GoHoist without tension chains correctly attached.

How to Attach the Tension Chains

The tension chains come in two pieces for each hoist. Each section forms a triangle, and one triangle has a tail of chain on one of its corners. This additional tail on one piece can be seen in the photo on the left side chain section. The two sections of chains are laid out for use as shown in the photo on the left. At each of the four corners (shown circled in red) is a quick link fastener. The two sections of chains are attached in the middle with a quick link fastener. The blue circle in the left photo, shows where the tail section of chain attaches to the other section of chain. Make sure there is no slack when attaching the tail section of chain to the other section of chain.

Each one of corner quick link fasteners will attach to the bottom of the four legs on one hoist unit. Each bottom leg of the hoist has an eyebolt attached to the foot. This is shown on the photo to the left. Attached the tension chain corners to the legs first, then attached the middle section as shown above.

It is also highly recommended that a pad of wood, preferably plywood, be placed under each foot for stability on smoother surfaces and also preventing the foot from sinking into soft ground.

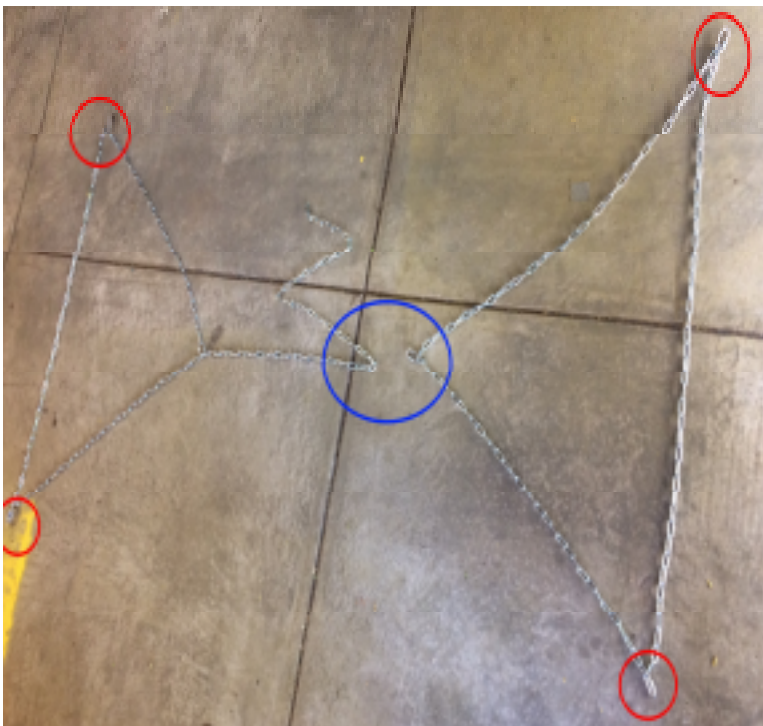



GoHoist.com Safety Notes

The same safety procedures and lift process should be followed for GoHoist as with a stationary boat hoist.

Use tension chains

Tension chains must be attached to the bottom of each leg of the lifting hoist. The tension chains should have no slack between each right and left foot. The tension chains between the port and starboard side hoist leg should be connected also, with no slack. Do not lift without tension chains properly secured to each foot of the lifting hoist. Tension chains are critical so that the legs do not slip and spread out causing failure of the lifting hoist.

Lift both front and back hoists evenly

Use GoHoist to lift the boat evenly. Do not lift one end completely up, this could cause the lifting strap to slip off. Using GoHoist two (2) hoist lift is the same as using a stationary hoist, both front and back must be lifted evenly. When lifting with GoHoist with two people, lift the back hoist first 3 inches, then move to the front hoist and lift it 6 inches, and move to the back hoist and lift another 6 inches. Continue this alternating lifting until the boat is at the needed height.

Block up boat

Once GoHoist.com lifts the boat and trailer is removed, always support the boat with lifting blocks or boat stands. Do not go under the boat or work on the boat while GoHoist.com alone is lifting the boat. Cinder blocks are never recommended for blocking up boats, wood timbers stacked on sides are recommended.

Align lifting points

Make sure that the lifting hooks on the hoist are aligned directly over the lifting point on the boat, both front to back and side to side. Do not lift a boat using one lift point per hoist. Use two lifting points for hoist and a line the lifting hooks on the hoist directly over the lifting point on the boat.

Use foot supports

When using hoist on smooth/slippery surfaces such as polished concrete or on a soft/wet surface such as grass or dirt use wooden support pads under each foot. Pads should be approximately 1 to 2 inches thick and big enough not to allow the foot to slip off.

Lift on level ground

Lifting hoists should not be used on an unlevel surface where one set of legs are more than 3 inches higher or lower than the opposing legs side to side. Front to back hoists can be higher or lower no more than 3 inches. Always lift the lower sides/ends first to level boat

Check fasteners

There are several key fasteners that must be checked and tightened. Quick links that secure the tension chains to the hoist feet, the snatch blocks on the winch pulley cable and the lifting eyebolts on the shoulder sections. To not tighten the lifting eyebolt knots completely, they should be loose so that the eyebolts turn freely, but completely threaded onto the eyebolt.

Instructions for Lifting Strap Placement

Lifting strap placement is essential for safe lifting of your boat. Some manufacturers place strap location marks on a boat's side deck. For sailboats the weight of the lifting straps should be evenly distributed between the straps. However, boat positioning usually results in some minor variations. A safe practice is for the straps to be attached at a slight inward angle (no more than 2 or 3 degrees, that is about 3" to 4" difference from bottom of strap to top of strap on boat rail) towards the center of the boat. This helps to counteract any tendency for the straps to slip forward or backwards. Extreme hull rise or other limiting design features required the straps be tied together in order to prevent slipping.

Moderate keel.

Safety lines may be used to prevent slipping. Lifting straps angled to prevent slippage towards the ends of the boat. Do not angle the straps inwards more than a few degrees. Just a few inches difference in strap placement from bottom to top of boat rail.

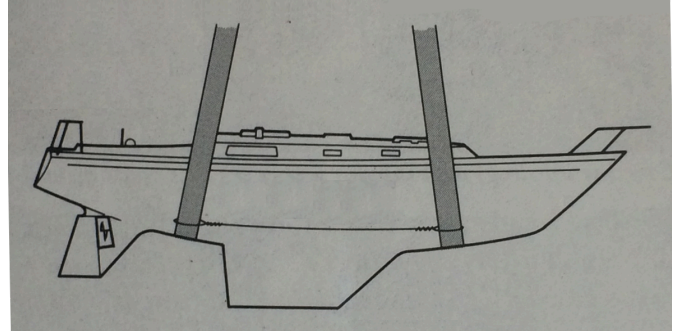

Fin keel.

A 90° angle at the strap to hull contact point makes the most effective anti-slip placement. Avoid steeply sloping keel/haul intersections. Do not angle the straps inwards more than a few degrees. Just a few inches difference in strap placement from bottom to top of boat rail.

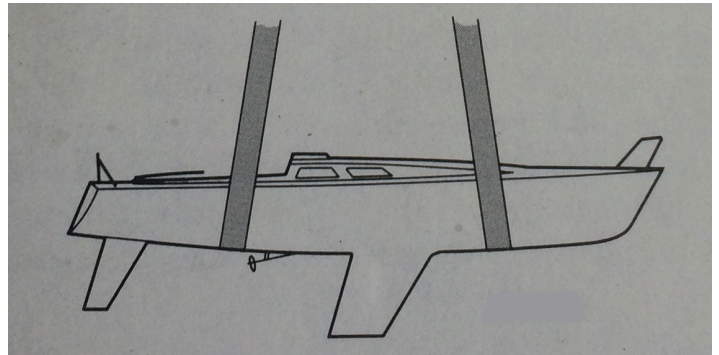

Traditional full keel.

Keep straps clear of fragile trailing edges on the keels and rudder and propeller shaft. Do not angle the straps inwards more than a few degrees. Just a few inches difference in strap placement from bottom to top of boat rail.

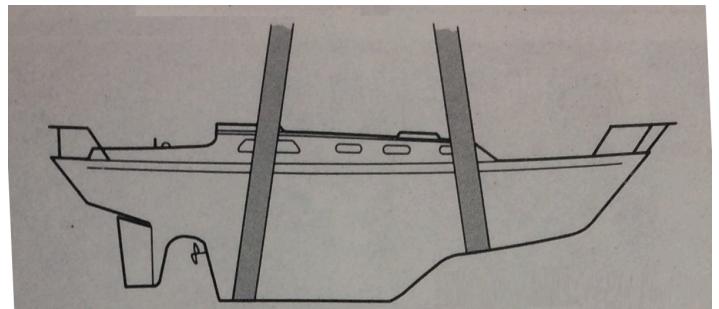

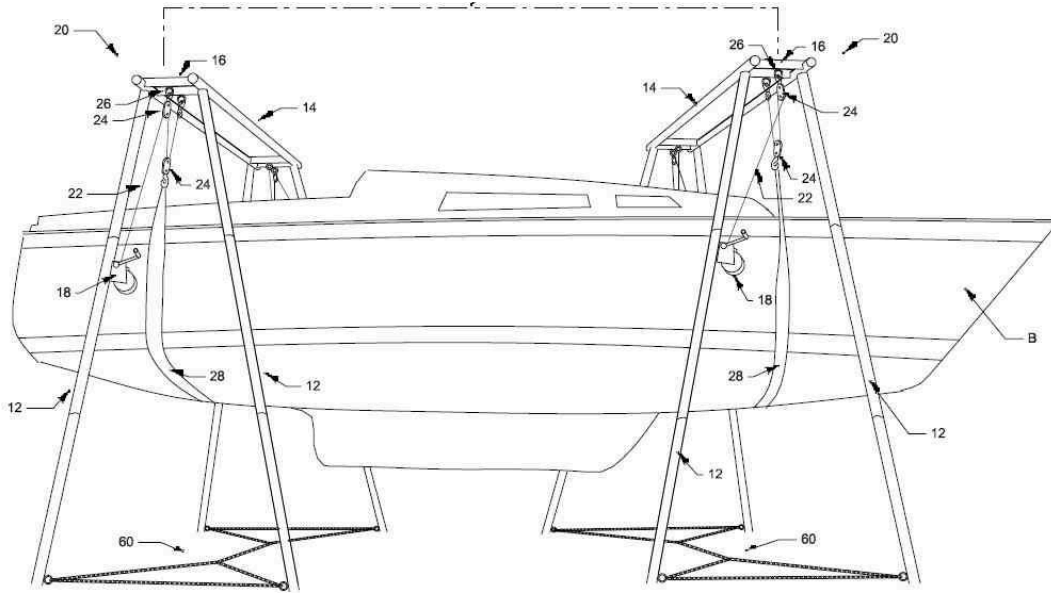

The image above shows the lifting straps centered over each hoist from the side. As the images from page one show the straps can be slightly angled inward from bottom to top.

When placing the lifting straps under the hull, make sure that the straps are centered under each hoist as follows.

When the hoists are in place over the boat, and the lifting straps are attached under the hull, view the boat from both the front and the back. Make sure that the center of the boat is under the center of both the back and front hoists. Move the hoists as needed till they are centered.

If the location of the boat or items around the boat do not allow for the hoist to be centered over the hull, you can still lift the boat. But be aware that as soon as the boat is lifted it will swing and move to be centered over each hoist.

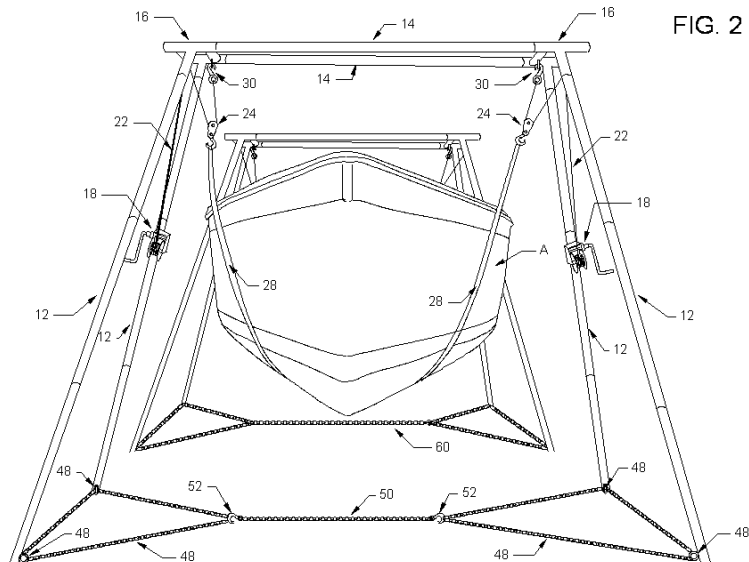

FIG. 2

The image above shows the hull not centered under the hoists. The boat can be lifted but will swing to the right.

GoHoist.com Lifting Chains Notes (Optional)

Use of lifting chains.

The GoHoist lifting chains are used when the lifting straps cannot be positioned under the hull of the boat. This is typically found on the transom (back) of powerboats and the bow and/or transom of pontoons.



Safety Notes:

The quick links that come on the end of the lifting chains are rated at half the strength of the chains and hooks. Always double over and loop the end of the chain with the quick link, and use the loop for attaching and lifting. This doubles the lifting capacity of the quick link because it is only lifting half the weight when looped.

Always completely screw in and close the quick link when lifting. Make sure that all the screw threads on the quick link are covered by the bolt sleeve. See photo of chain with end loop below.



Lifting Beam (Optional)

If you need to lift a boat or other load from a single point that does not allow you to load both right and left winches vertically and with the same weight, you can use a lifting beam, as shown in the image below. This lifting beam is a 6' GoHoist unit for use with GoHoist lifts for loads up to 2 tons.



GoHoist Lifting Beam is a 4"x 3" I beam 6' width and comes with one lifting chain(s) and hook. Lifting eyes are 1/8" steel welded to the beam.

Note: Without Lifting Beam loads with the rigging angled inwards reduces lifting capacity and also stresses the hoist in ways it was not designed for. The GoHoist is designed to lift loads vertically straight up from the shoulders.

GoHoist.com Foot Pad Notes (Optional)

Use of foot pads.

The GoHoist foot pads are made to go on either right or left legs on each side of the GoHoist. The notch/seam on the foot pad sleeve is positioned on the inside of each leg.

The GoHoist foot pads are manufactured so that they have the same 12 degree angle as the legs. Make sure that the higher part of the foot pad sleeve is facing the outside of the hoist leg - the side where the tension chain nut and washer is positioned. View the images below.

Attach the foot pads by loosening the tension chain eyebolt nuts enough for the castor foot cap to slip on to the bottom of the leg and completely over the eye bolt shaft, when lined up with the notches on the top of the foot pad. Make sure that the washer is on the outside of the foot pad and hand tighten the bolts so that the foot pad does not slip down off the leg. The eyebolt nuts do not have to be tight for lifting. Review images below.



Viewing one hoist from side.



GoHoist Warranty

GoHoist boat hoists are warranted to be free from defects in material and workmanship for the life of the product. This warranty is for the GoHoist structure only and does not include wear components, such as winches, rigging or hardware. All non-structure components have a 30 days warranty from date of purchase. Please report any such defects to GoHoist for verification. If such defects are verified, GoHoist will replace or repair that structure part at no charge.

All GoHoist warranties are void if damage to the GoHoist structure or wear components is the result of improper use or storage of the GoHoist.

Contact us for more information:

Call or text: (937) 404-1818

7am-4pm EST, Monday-Friday

Email: info@gohoist.com