

**UN MÉTODO CONSTRUCTIVO INNOVADOR PARA TÚNELES  
basado en el control de las deformaciones del frente**



**Gianfranco Perri**  
[www.gianfrancoperri.com](http://www.gianfrancoperri.com)

# Túneles excavados de manera convencional mediante el método ADECO

*prof. Gianfranco Perri*

[www.gianfrancoperri.com](http://www.gianfrancoperri.com)



*Bogotá 9 de Noviembre 2014*



# Túneles excavados convencionalmente mediante el método ADECO

*prof. Gianfranco Perri*

[www.gianfrancoperri.com](http://www.gianfrancoperri.com)



*Bogotá 19 de Junio 2015*



# Túneles excavados convencionalmente mediante el método “ADECO”

Un método constructivo innovador para túneles en condiciones críticas basado en el control de las deformaciones del frente

*prof. Gianfranco Perri*

[www.gianfrancoperri.com](http://www.gianfrancoperri.com)



**Bogotá 6 de Agosto 2016**



# *Cómo se puede comportar una excavación?*

- ◆ Muy bien
- ◆ Medianamente bien
- ◆ Medianamente mal
- ◆ Muy mal

# POSIBLES CONDICIONES GEOESTATICAS DURANTE LA EXCAVACION DE UN TUNEL

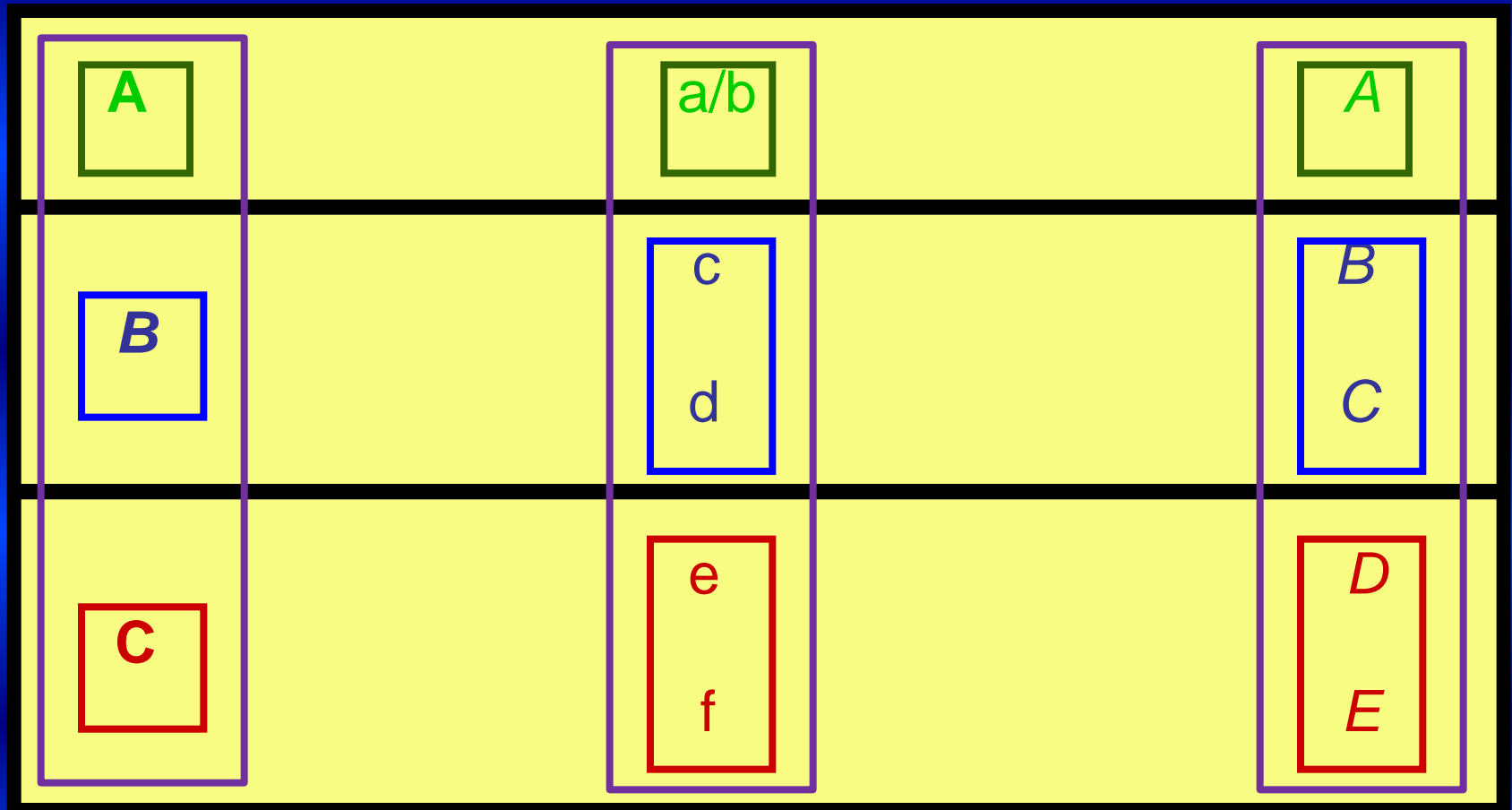

# Escenarios o Clases de Comportamiento de una Excavación

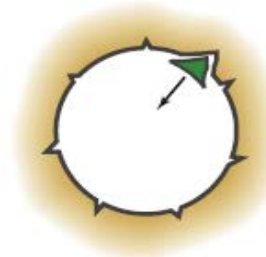
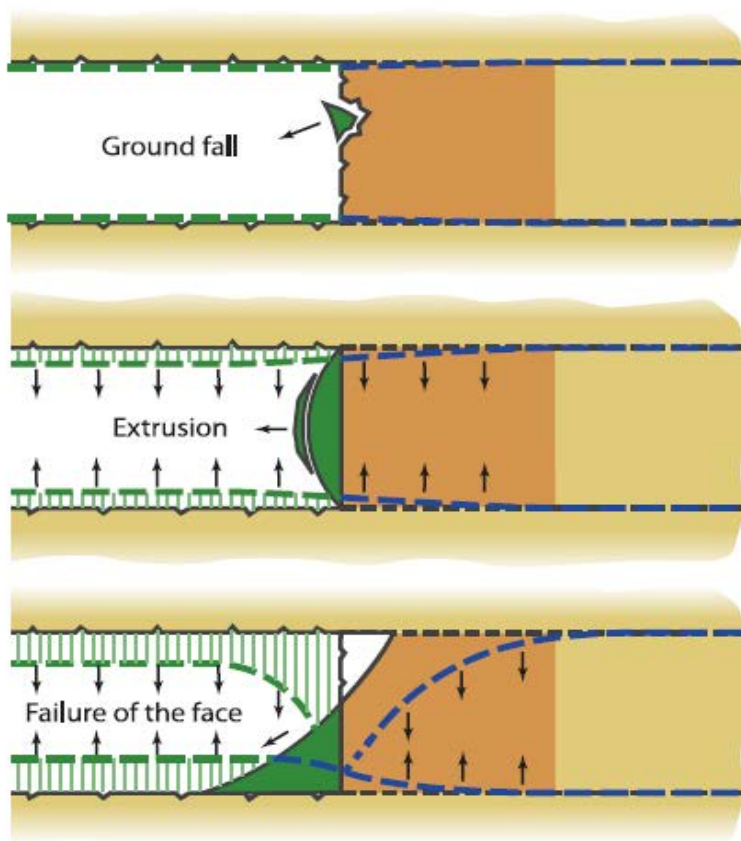

Ground fall

A

Stable face



Preconvergence and convergence

B

Face stable in the short term



Collapse of the cavity

C

Unstable face

## **A** Comportamiento a frente estable o, de tipo lapídeo

*La concentración de esfuerzos en el terreno al frente y al contorno de la cavidad no supera la resistencia del medio.*

*Los fenómenos de deformación evolucionan en campo elástico, son inmediatos y de orden centimétrico.*

*El frente de excavación es globalmente estable y se pueden producir solamente inestabilidades localizadas de caída de bloques aislados debido a desfavorables circunstancias geométricas y estructurales del terreno.*

*Las **intervenciones de protección** o estabilización están principalmente dirigidas a evitar eventuales desprendimientos localizados del terreno.*



Clase de Comportamiento " A-1 "



21 6 2005



Clase de Comportamiento "A-2"

## **B Comportamiento a frente estable a corto plazo o, de tipo cohesivo**

*La concentración de esfuerzos al frente y al contorno de la cavidad, supera el límite del campo elástico del medio.*

*Los fenómenos de deformación evolucionan en campo elástico-plástico, son algo diferidos en el tiempo, son de orden decimétrico y no condicionan la estabilidad ya que el terreno está aún en condición de movilizar resistencia suficiente.*

*Los fenómenos de inestabilidad, bajo la forma de desprendimientos localizados presentes en el frente y contorno de la cavidad, dejan en general el tiempo de actuar después de un relativamente limitado alejamiento del frente, mediante **intervenciones tradicionales de contención radial** aunque, en raras circunstancias, puede resultar necesario recurrir al empleo de algunas acciones de pre-consolidación y/o de pre-contención.*

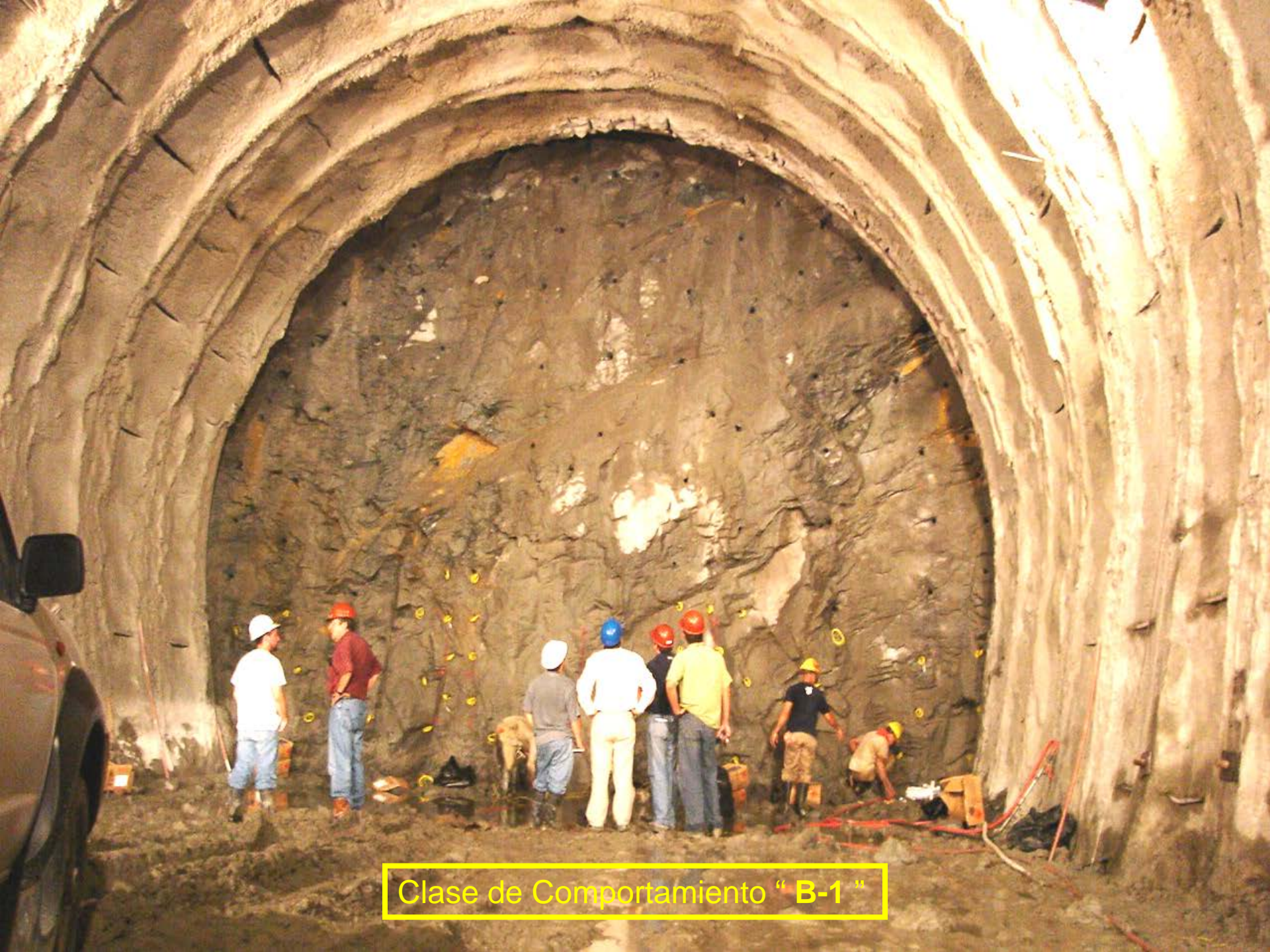

Clase de Comportamiento "B-1"



Clase de Comportamiento " B-2 "

# Las intervenciones tradicionales de contención radial

## RESISTENCIA O CAPACIDAD DE CONTRASTE DE SOPORTES para túneles de aproximadamente 10m de diámetro

<i>Tipo de Soporte</i>	<i>Concreto Proyectado</i>	<i>Costillas Metálicas</i>	<i>Pernos Metálicos 20 t</i>	<i>Capacidad (Kg/cm<sup>2</sup>)</i>
<b>SP-a</b>	10 cm	-	eventuales	1,5
<b>SP-b</b>	14 cm	2 IPN140 @ 150 cm	2 x 4 m @ par de costillas	2,5
		o, alternamente 7 pernos x 4m @ 150 cm (sin costillas)		
<b>SP-c</b>	16 cm	2 IPN160 @ 125 cm	4 x 6 m @ par de costillas	3,5
		o, alternamente 11 pernos x 6m @ 125 cm (sin costillas)		
<b>SP-d</b>	20 cm	2 IPN200 @ 100 cm	6 x 6 m @ par de costillas	4,5
		o, alternamente 15 pernos x 6m @ 100 cm (sin costillas)		
<b>SP-e</b>	20 cm	2 IPN200 @ 075 cm	10 x 6 m @ par de costillas	6,5

## **C Comportamiento a frente inestable o, de tipo incoherente**

*La concentración de esfuerzos al frente y al contorno de la cavidad, supera la resistencia del medio.*

*Los fenómenos de deformación resultan inaceptables ya que evolucionan rápidamente hacia la ruptura dando lugar a graves manifestaciones de inestabilidad hasta la caída del frente y el colapso de la cavidad, sin dejar el tiempo de actuar con intervenciones de contención radial.*

*Se requieren por lo tanto siempre intervenciones especiales a monte del frente de excavación, por ejemplo:*

***parcialización de la sección  
pre-consolidación - pre-soporte - “pre-contención”***

# CLASE DE COMPORTAMIENTO DE LA EXCAVACIÓN

## I Intervenciones de protección

- \* *Concreto proyectado*
- \* *Pernos aislados*

## II Intervenciones tradicionales de contención radial

- \* *Concreto proyectado y Pernos sistemáticos*
- \* *Concreto proyectado y Costillas (eventualmente con Pernos)*

## III Intervenciones de pre-consolidación y/o pre-contención y/o pre-soporte

- \* *Concreto proyectado costillas y pernos*
- \* *Vidrioresinas de consolidación del núcleo*
- \* *Pernos en avance*
- \* *Arco troncocónico de micropilotes o, de jet grouting*
- \* *Arco troncocónico en pre-corte de concreto*
- \* *Solera temporal (eventualmente a media sección)*
- \* .....



# DE QUE DEPENDE LA CLASE DE COMPORTAMIENTO DE UNA EXCAVACIÓN?

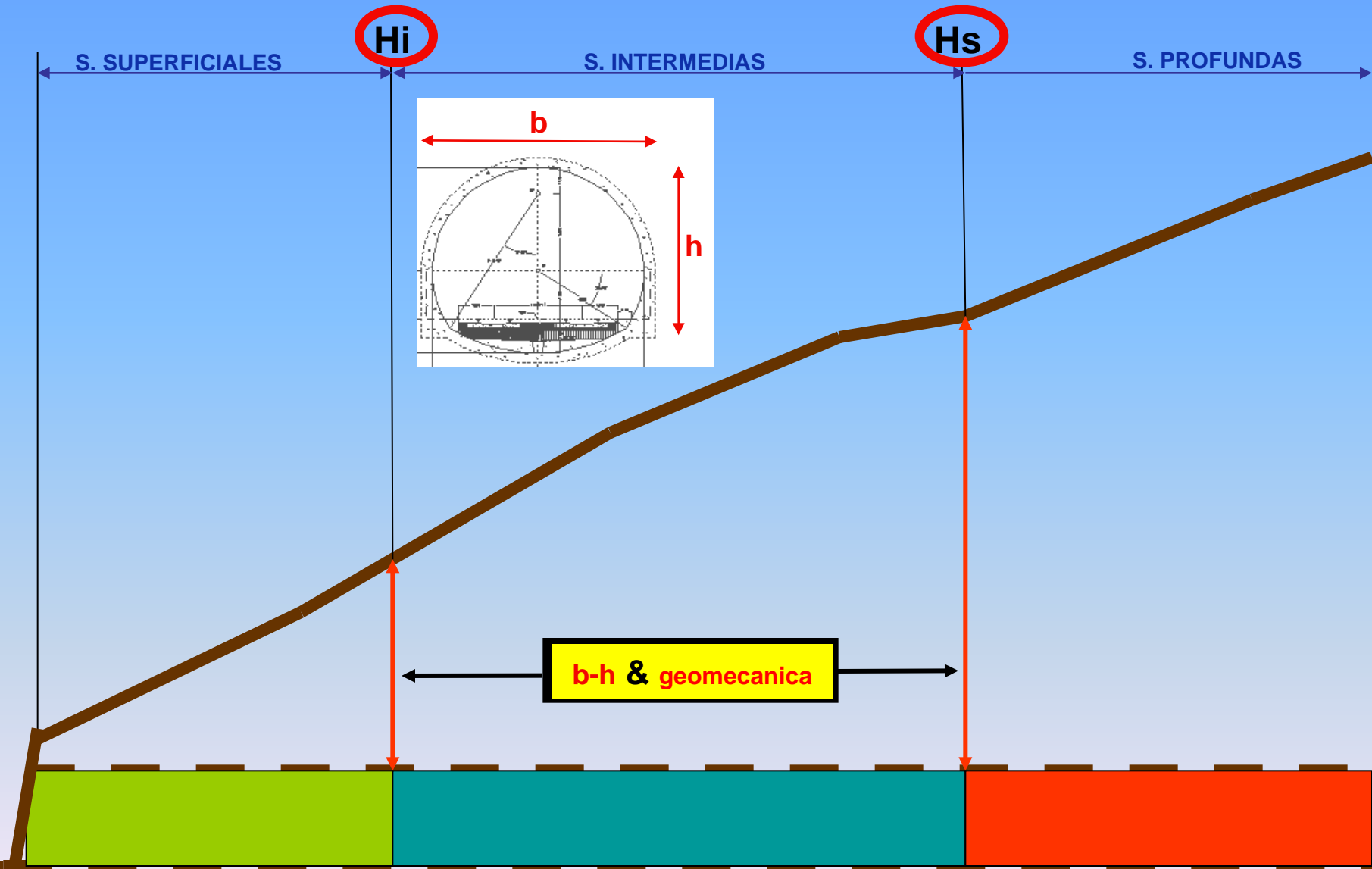

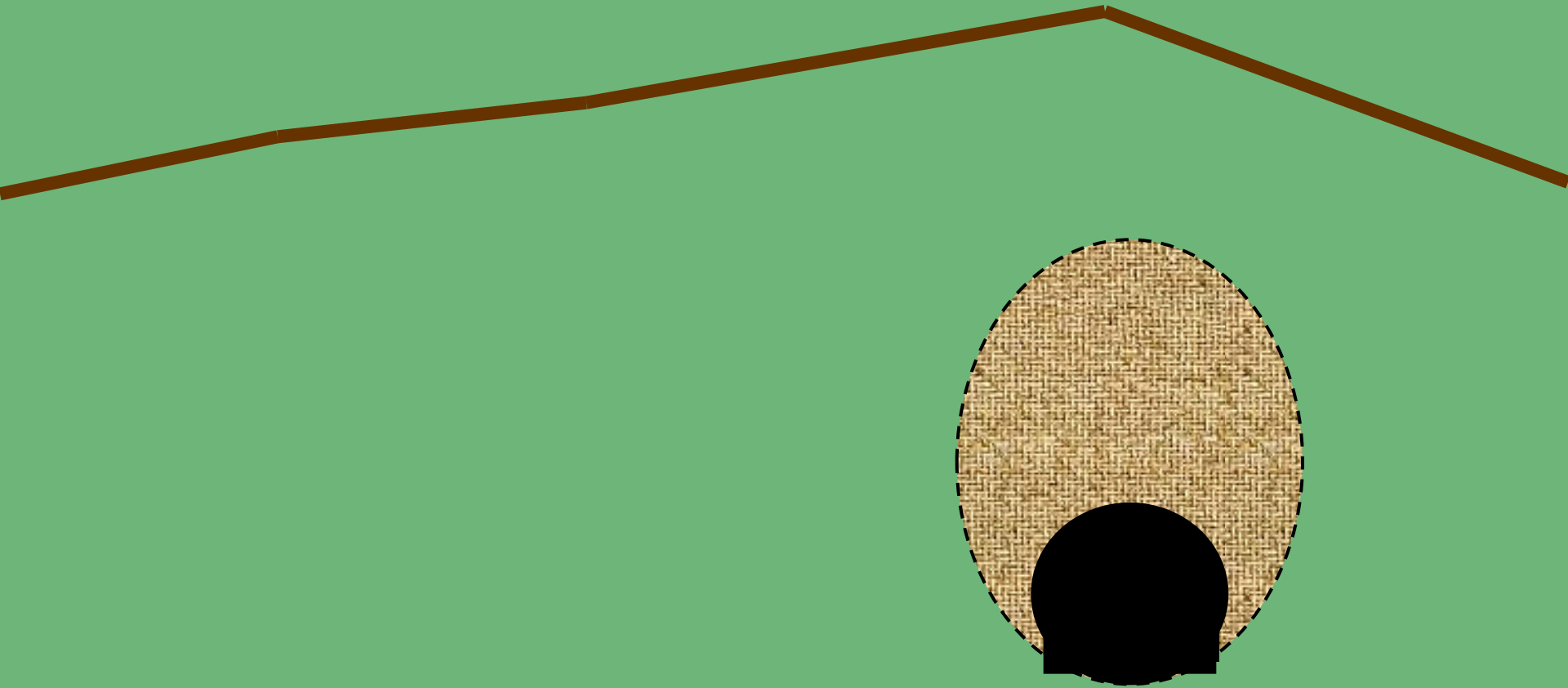

**Comportamiento Geomecánico de las Secciones Intermedias**



**RMR** de Bieniawski

**Q** de Barton

**RMi** de Palmstron

**GSI** de Hoek

...

**Comportamiento Geomecánico de las Secciones Intermedias**

# PRINCIPALES CLASIFICACIONES GEOMECAICAS

Name of classification	Form and Type*)	Main applications	Reference
The Terzaghi rock load classification system	Descriptive and behaviouristic form Functional type	For design of steel support in tunnels	Terzaghi, 1946
Lauffer's stand-up time classification	Descriptive form General type	For input in tunnelling design	Lauffer, 1958
The new Austrian tunnelling method (NATM)	Descriptive and behaviouristic form Tunnelling concept	For excavation and design in incompetent (overstressed) ground	Rabcewicz, Müller and Pacher, 1958 - 64
Rock classification for rock mechanical purposes	Descriptive form General type	For input in rock mechanics	Patching and Coates, 1968
The unified classification of soils and rocks	Descriptive form General type	Based on particles and blocks for communication	Deere et al., 1969
The rock quality designation (RQD)	Numerical form General type	Based on core logging; used in other classification systems	Deere et al., 1967
The size-strength classification	Numerical form Functional type	Based on rock strength and block diameter; used mainly in mining	Franklin, 1975
The rock structure rating (RSR) classification	Numerical form Functional type	For design of (steel) support in tunnels	Wickham et al., 1972
The rock mass rating (RMR) classification	Numerical form Functional type	For use in tunnel, mine and foundation design	Bieniawski, 1973
The Q classification system	Numerical form Functional type	For design of support in underground excavations	Barton et al., 1974
The typological classification	Descriptive form General type	For use in communication	Matula and Holzer, 1978
The unified rock classification system	Descriptive form General type	For use in communication	Williamson, 1980
Basic geotechnical classification (BGD)	Descriptive form General type	For general use	ISRM, 1981
The Geological Strength Index (GSI)	Numerical form Functional type	For design of support in underground excavations	Hoek, 1994
The Rock Mass index (RMI) system	Numerical form Functional type	For general characterisation, design of support, TBM progress	Palmström, 1995

**Parámetros de clasificación**

1	Resistencia de la matriz rocosa (MPa)	Ensayo de carga puntual	> 10	10-4	4-2	2-1	Compresión simple (MPa)		
		Compresión simple	> 250	250-100	100-50	50-25	25-5	5-1	< 1
	Puntuación		15	12	7	4	2	1	0
2	RQD		90 %-100 %	75 %-90 %	50 %-75 %	25 %-50 %	< 25 %		
	Puntuación		20	17	13	6	3		
3	Separación entre diaclasas		> 2 m	0,6-2 m	0,2-0,6 m	0,06-0,2 m	< 0,06 m		
	Puntuación		20	15	10	8	5		
4	Estado de las discontinuidades	Longitud de la discontinuidad	< 1 m	1-3 m	3-10 m	10-20 m	> 20 m		
		Puntuación	6	4	2	1	0		
		Abertura	Nada	<0,1 mm	0,1-1,0 mm	1-5 mm	> 5 mm		
		Puntuación	6	5	3	1	0		
		Rugosidad	Muy rugosa	Rugosa	Ligeramente rugosa	Ondulada	Suave		
		Puntuación	6	5	3	1	0		
		Relleno	Ninguno	Relleno duro <5 mm	Relleno duro >5 mm	Relleno blando <5 mm	Relleno blando >5 mm		
		Puntuación	6	4	2	2	0		
		Alteración	Inalterada	Ligeramente alterada	Moderadamente alterada	Muy alterada	Descompuesta		
		Puntuación	6	5	3	1	0		
5	Agua freática	Caudal por 10 m de túnel	Nulo	< 10 litros/min	10-25 litros/min	25-125 litros/min	> 125 litros/min		
		Relación: Presión de agua/Tensión principal mayor	0	0-0,1	0,1-0,2	0,2-0,5	> 0,5		
		Estado general	Seco	Ligeramente húmedo	Húmedo	Goteando	Agua fluyendo		
	Puntuación		15	10	7	4	0		

**Corrección por la orientación de las discontinuidades**

Dirección y buzamiento		Muy favorables	Favorables	Medias	Desfavorables	Muy desfavorables
Puntuación	Túneles	0	-2	-5	-10	-12
	Cimentaciones	0	-2	-7	-15	-25
	Taludes	0	-5	-25	-50	-60

**RMR = A1 + A2 + A3 + A4 + A5 + B**

**Clasificación de BENIAWSKI – 1974 - 1989**

Estimación de parámetros que intervienen en el índice Q (simplificado de Barton et al., 1974)

Índice de diaclasado $J_n$ (*)		Índice de rugosidad $J_r$	
Roca masiva	0,5-1,0	Diaclasas rellenas	1
Una familia de diaclasas	2	Diaclasas limpias (*)	
Id. con otras diaclasas ocasionales	3	— Discontinuas	4
Dos familias de diaclasas	4	— Onduladas, rugosas	3
Id. con otras diaclasas ocasionales	6	— Onduladas, lisas	2
Tres familias de diaclasas	9	— Planas, rugosas	1,5
Id. con otras diaclasas ocasionales	12	— Planas, lisas	1,0
Cuatro o más familias, roca muy fracturada	15	Lisos o espejos de falla	
Roca triturada	20	— Ondulados	1,5
		— Planos	0,5

(\*) En embocaduras  $2 \times J_n$

$$Q = \frac{RQD}{J_n} \cdot \frac{J_r}{J_a} \cdot \frac{J_w}{SRF}$$

(\*) O cuyas caras entran en contacto bajo la sollicitación

Índice de alteración $J_a$	Coficiente reductor por la presencia de agua $J_w$	Presión de agua (Kg/cm <sup>2</sup> )
Diaclasas de paredes sanas	0,75-1	Excavaciones secas o con < 5 l/min localmente
Ligera alteración	2,0	
Alteraciones arcillosas	4,0	Afluencia media con lavado de algunas diaclasas
Con detritus arenosos	4,0	
Con detritus arcillosos preconsolidados	6,0	Afluencia importante por diaclasas limpias.
Id. poco consolidados	8,0	
Id. expansivos	8-12	Id. con deslavado de diaclasas
Milonitos de roca y arcilla	6-12	
Milonitos de arcilla limosa	5	Afluencia excepcional inicial, decreciente con el tiempo.
Milonitos arcillosos-gruesos	10-20	
		Id. mantenida

Parámetro SRF

— Zonas débiles:		
Multitud de zonas débiles o milonitos	10,0	
Zonas débiles aisladas, con arcilla o roca descompuesta (cobertura $\leq 50$ m)	5,0	
Id. con cobertura > 50 m	2,5	
Abundantes zonas débiles en roca competente	7,5	
Zonas débiles aisladas en roca competente (c. $\leq 50$ m)	5,0	
Id. con c. > 50 m	2,5	
Terreno en bloques muy fracturado	5,0	
— Roca competente:		
Pequeña cobertura	2,5	
Cobertura media	1,0	
Gran cobertura	0,5-2,0	
— Terreno fluyente:		
Con bajas presiones	5-10	
Con altas presiones	10-20	
— Terreno expansivo:		
Con presión de hinchamiento moderada	5-10	
Con presión de hinchamiento alta	10-15	

# CLASIFICACIÓN GEOMECANICA Vs. GSI (Geological Strength Index)

*Hevert Hoek 1994*

Condición de las Discontinuidades	MUY BUENA (VG)	BUENA (G)	REGULAR (F)	POBRE (P)	MUY POBRE (MP)
<b>Macizo Rocosó EN BLOQUES (B)</b>	> 65	55 - 75	45 - 65	35 - 55	25 - 45
<b>Macizo Rocosó FRACTURADO (VB)</b>	55 - 75	45 - 65	35 - 55	25 - 45	15 - 35
<b>Macizo Rocosó FALLADO Y PLEG. (BF)</b>	45 - 65	35 - 55	30 - 45	20 - 40	10 - 30
<b>Macizo Rocosó TOT. FRACTURADO (C)</b>	40 - 55	30 - 45	25 - 40	15 - 30	< 20

# El "Geological Strength Index" (GSI)

En 1994, Evert Hoek publicó en el noticiero de la Sociedad Internacional de Mecánica de Rocas, el artículo "*Strength of Rock and Rock Masses*" en el cual introdujo, definiéndolo "Geological Strength Index", un nuevo índice de calidad geomecánica para los macizos rocosos cuyo rango numérico, comprendido entre 0 y 100, se basa en la identificación y clasificación en campo de dos de las características físico-mecánicas de un macizo rocoso: la macroestructura y la condición de las superficies de las discontinuidades presentes.

Hoek recomienda hacer siempre referencia a un rango numérico y nunca a un solo valor del GSI y también sugiere la posibilidad, a falta de una apreciación directa en campo y solo para macizos rocosos caracterizados por un  $GSI > 25$ , de estimar este a partir del RMR de Bieniawski, depurándolo del factor orientación de las discontinuidades y asignando 10 al factor agua. También se propone estimar el GSI a partir del índice Q de Barton, depurándolo del factor de tensión (SRF) y asignando 1 al parámetro agua ( $J_w$ ), obteniendo luego, de acuerdo con la preexistente correlación entre Q y RMR:  $GSI = 9 \lg Q' + 44$ .



Rock Type:

General

GSI Selection:

31

**SURFACE CONDITIONS**

VERY GOOD

GOOD

FAIR

POOR

VERY POOR

**STRUCTURE**

DECREASING SURFACE QUALITY 

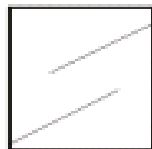

**INTACT OR MASSIVE** - intact rock specimens or massive in situ rock with few widely spaced discontinuities

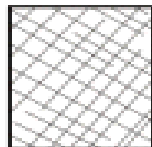

**BLOCKY** - well interlocked undisturbed rock mass consisting of cubical blocks formed by three intersecting discontinuity sets

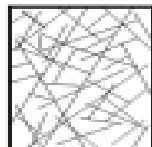

**VERY BLOCKY**- interlocked, partially disturbed mass with multi-faceted angular blocks formed by 4 or more joint sets

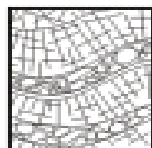

**BLOCKY/DISTURBED/SEAMY** - folded with angular blocks formed by many intersecting discontinuity sets. Persistence of bedding planes or schistosity

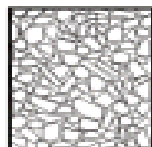

**DISINTEGRATED** - poorly interlocked, heavily broken rock mass with mixture of angular and rounded rock pieces



**LAMINATED/SHEARED** - Lack of blockiness due to close spacing of weak schistosity or shear planes

DECREASING INTERLOCKING OF ROCK PIECES 

	90			N/A	N/A
	80				
		70			
		60			
			50		
			40		
				30	
					20
					10
	N/A	N/A			

# EL "R<sub>Mi</sub>" (Rock Mass index) DE PALMSTROM - 1996

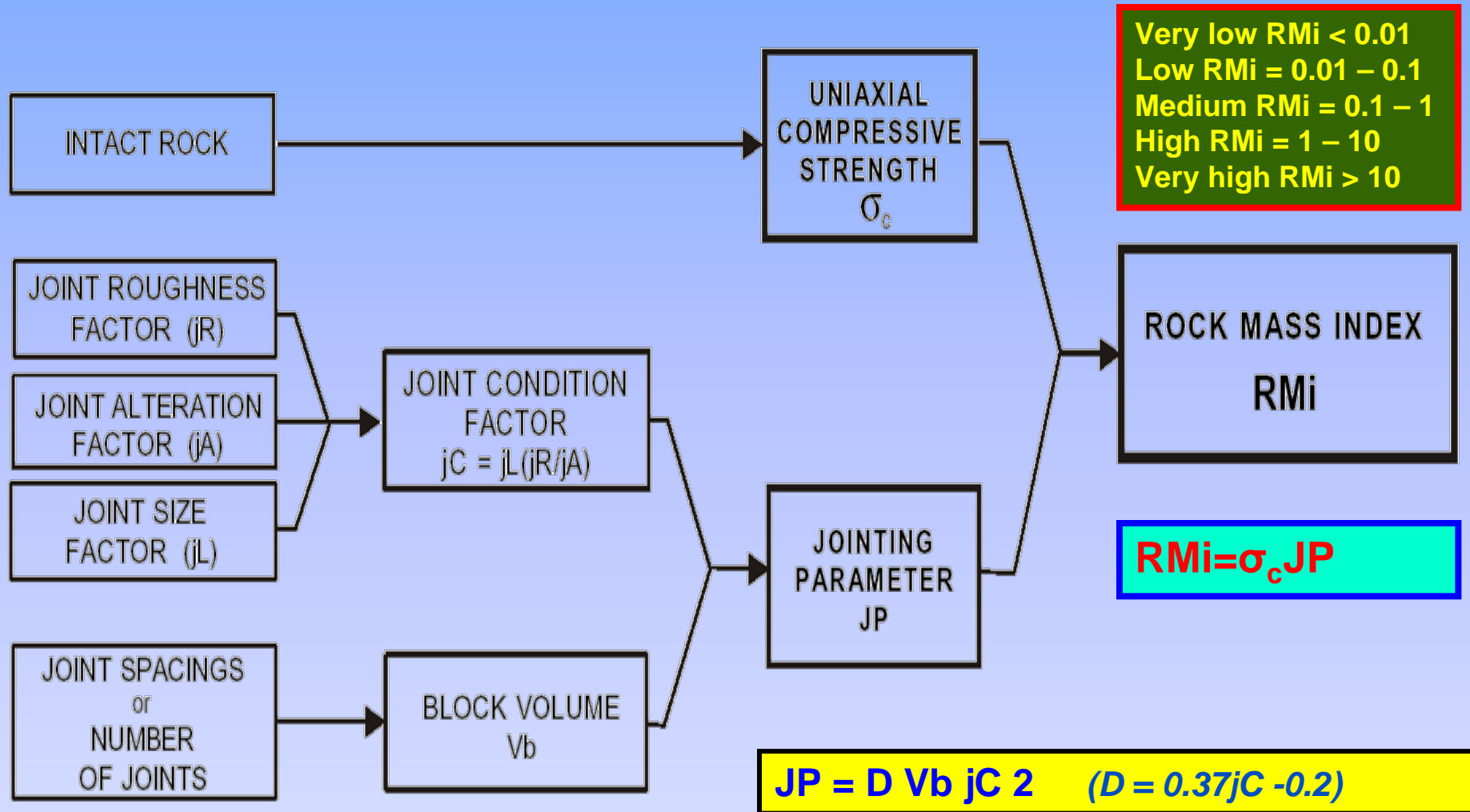

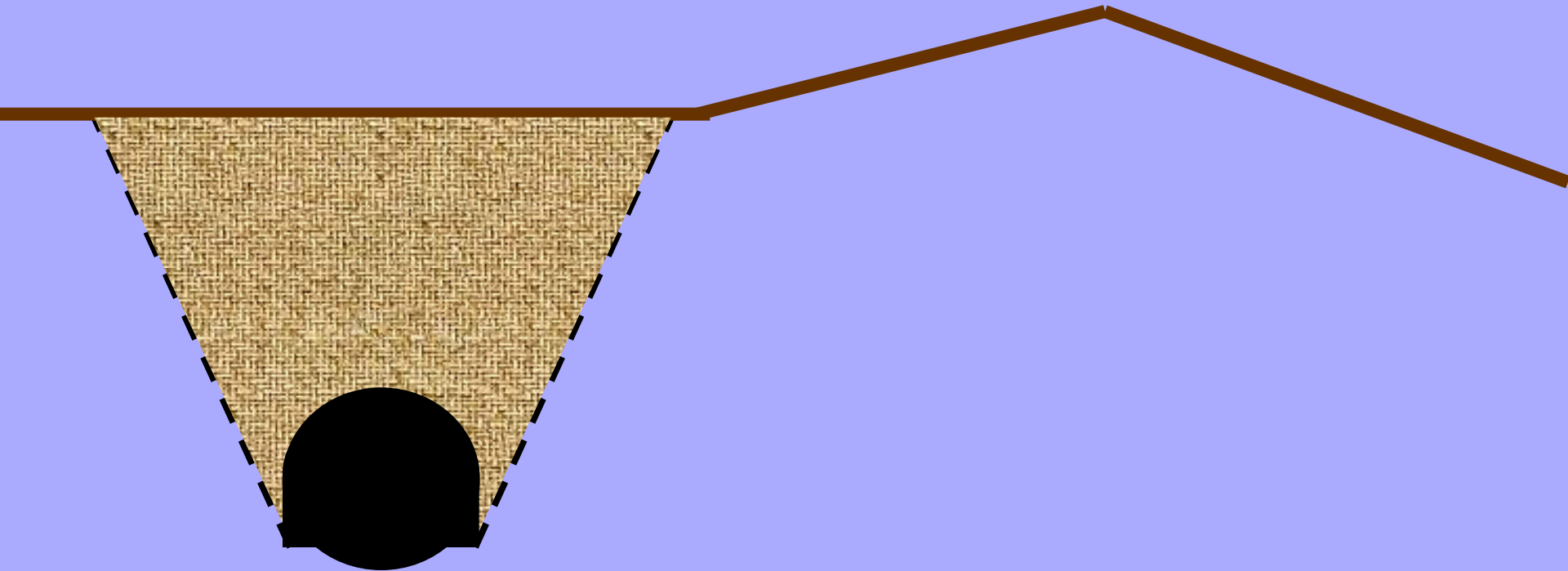

**Comportamiento Geomecánico de las Secciones Superficiales**

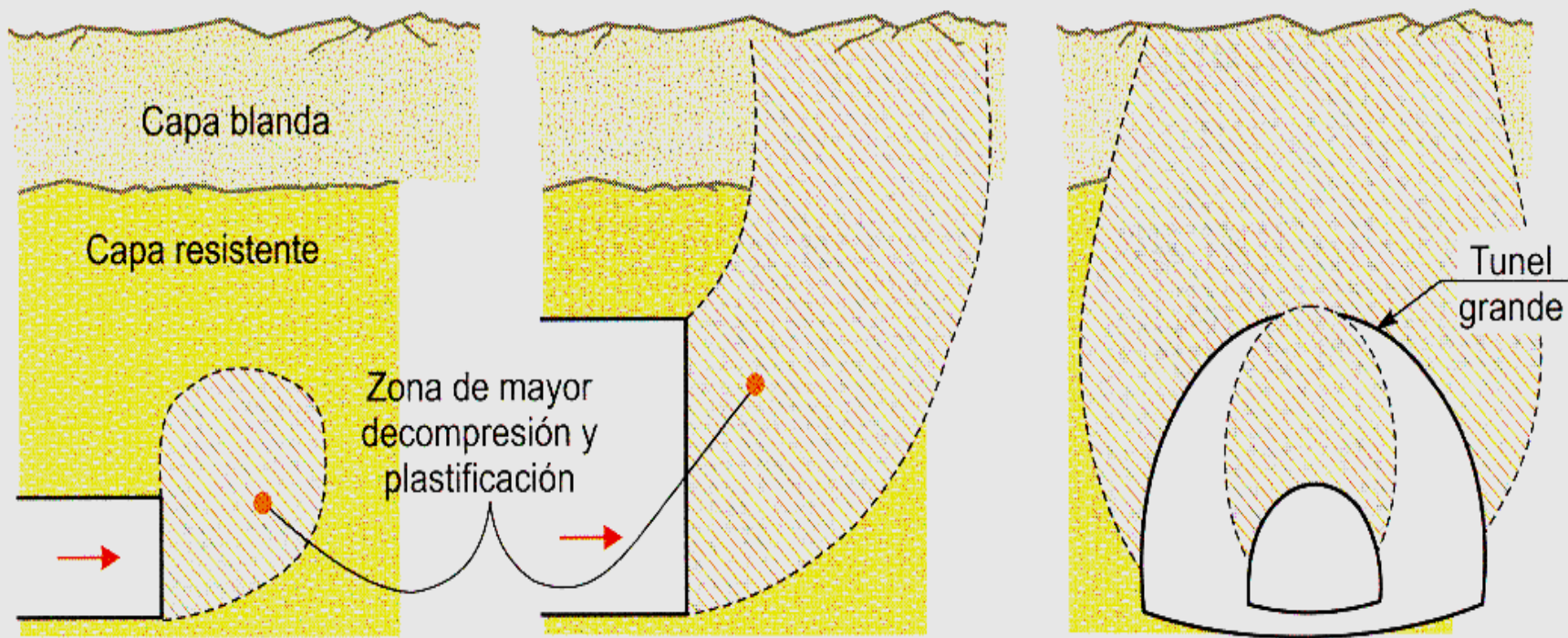

## Comportamiento Geomecánico de las Secciones Superficiales

# Comportamiento Geomecánico de las Secciones Superficiales

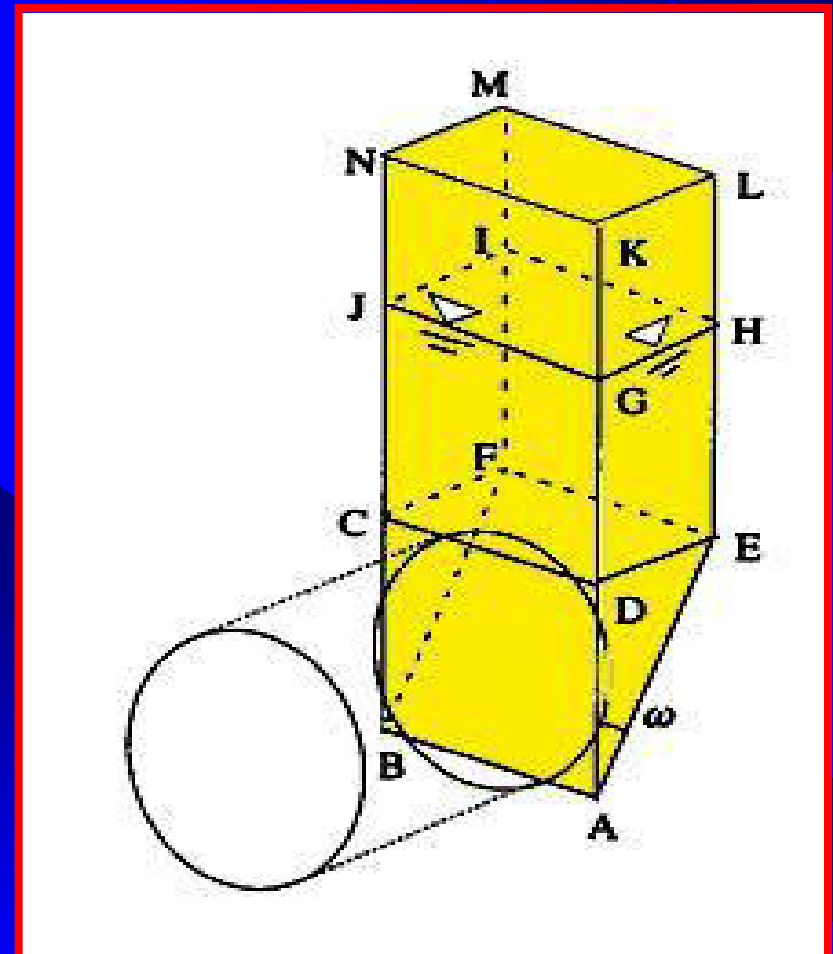
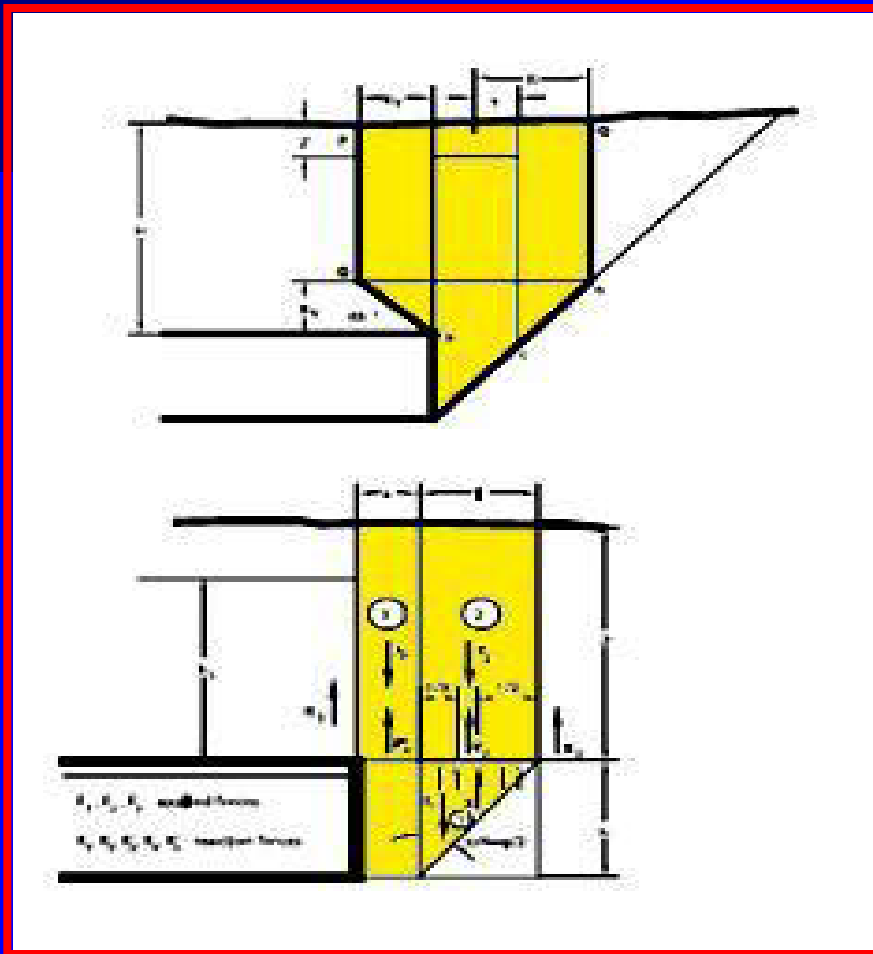

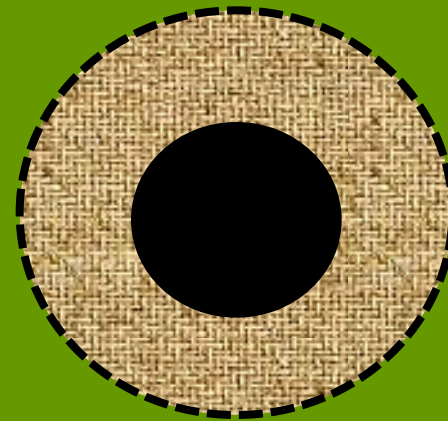

**Comportamiento Geomecánico de las Secciones Profundas**

# Comportamiento Geomecánico de las Secciones Profundas

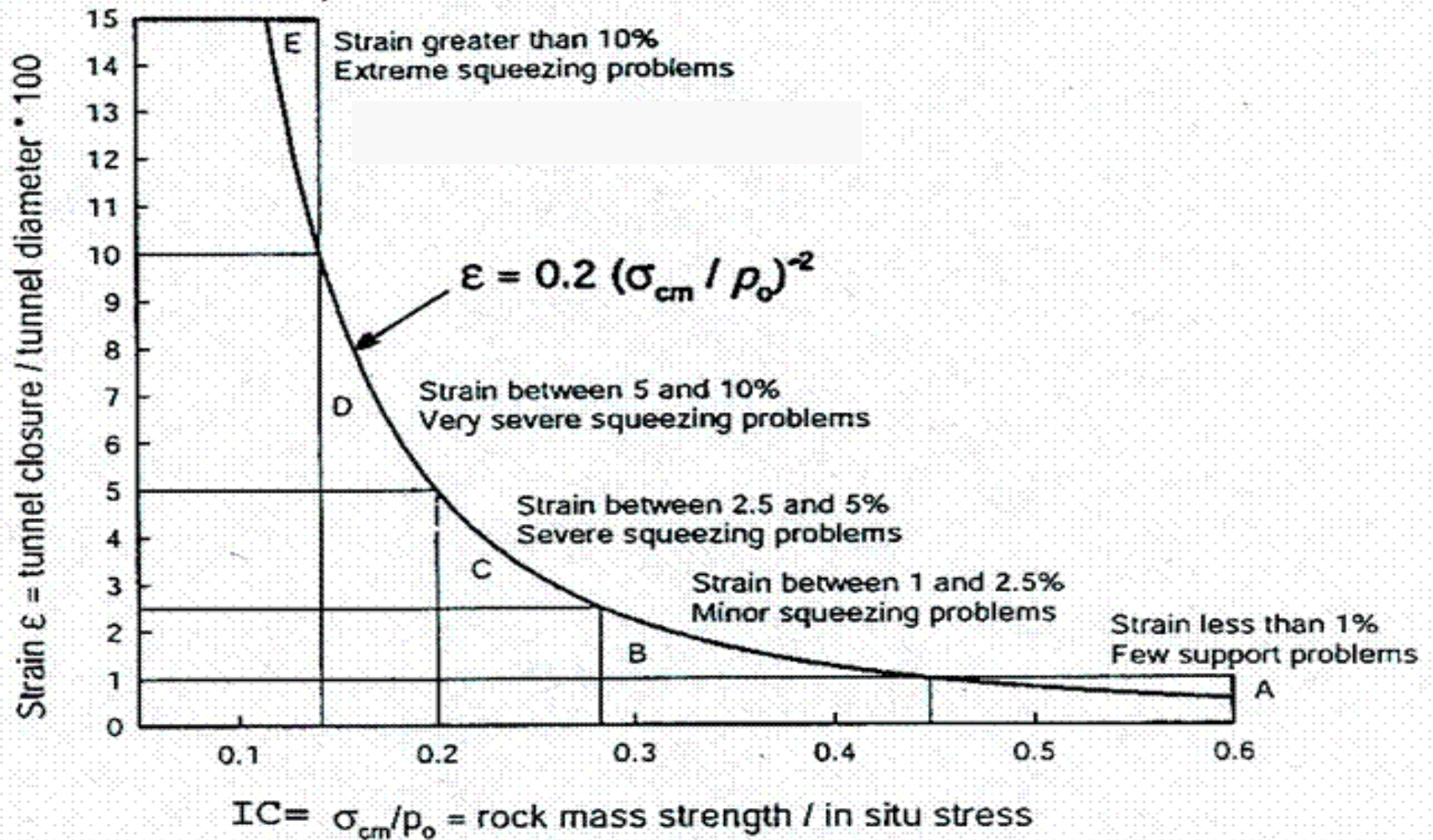

$$IC = \sigma_{cm} / \gamma H = (0.0034 m^{0.8}) \sigma_{ci} [1.029 + 0.025 e^{-0.1 m}] GSI / \gamma H$$

# CARGAS SOBRE EL SOPORTE Vs LA COBERTURA (H) Y EL TIPO DE ROCAS ( $\alpha$ -GSI)

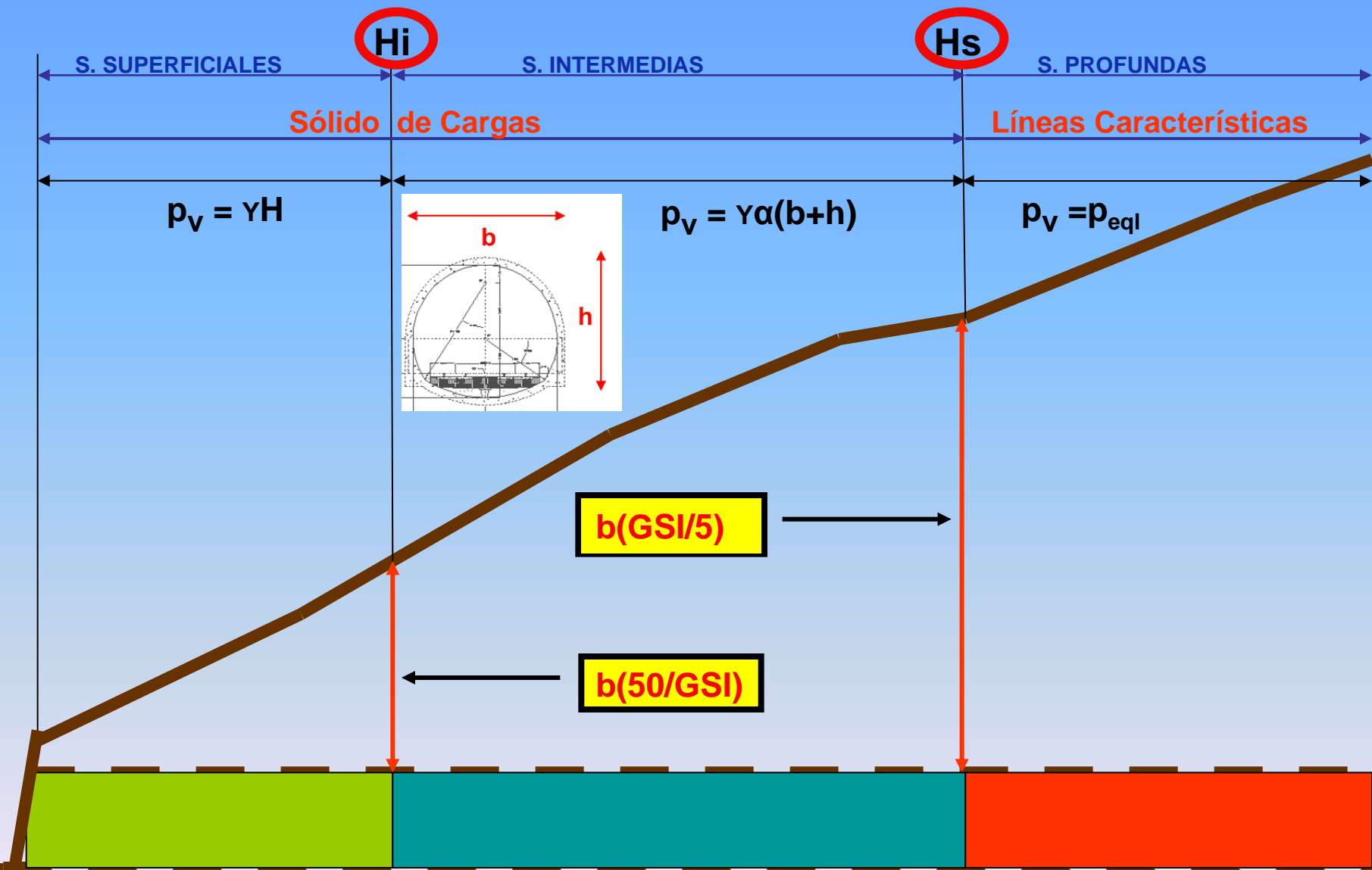



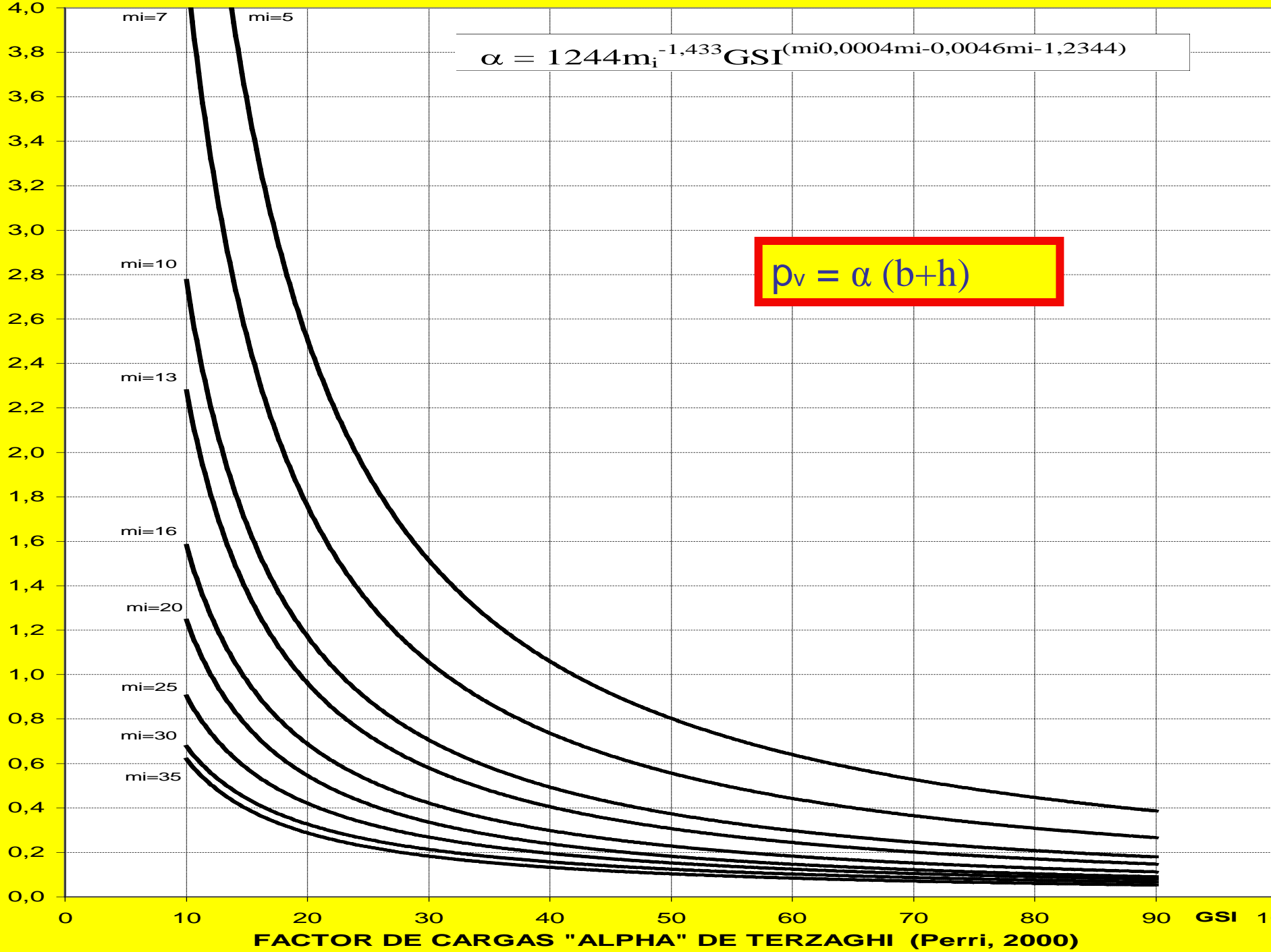

# Curvas de Interaccion Soporte - Terreno y Extencion de la Plastificacion

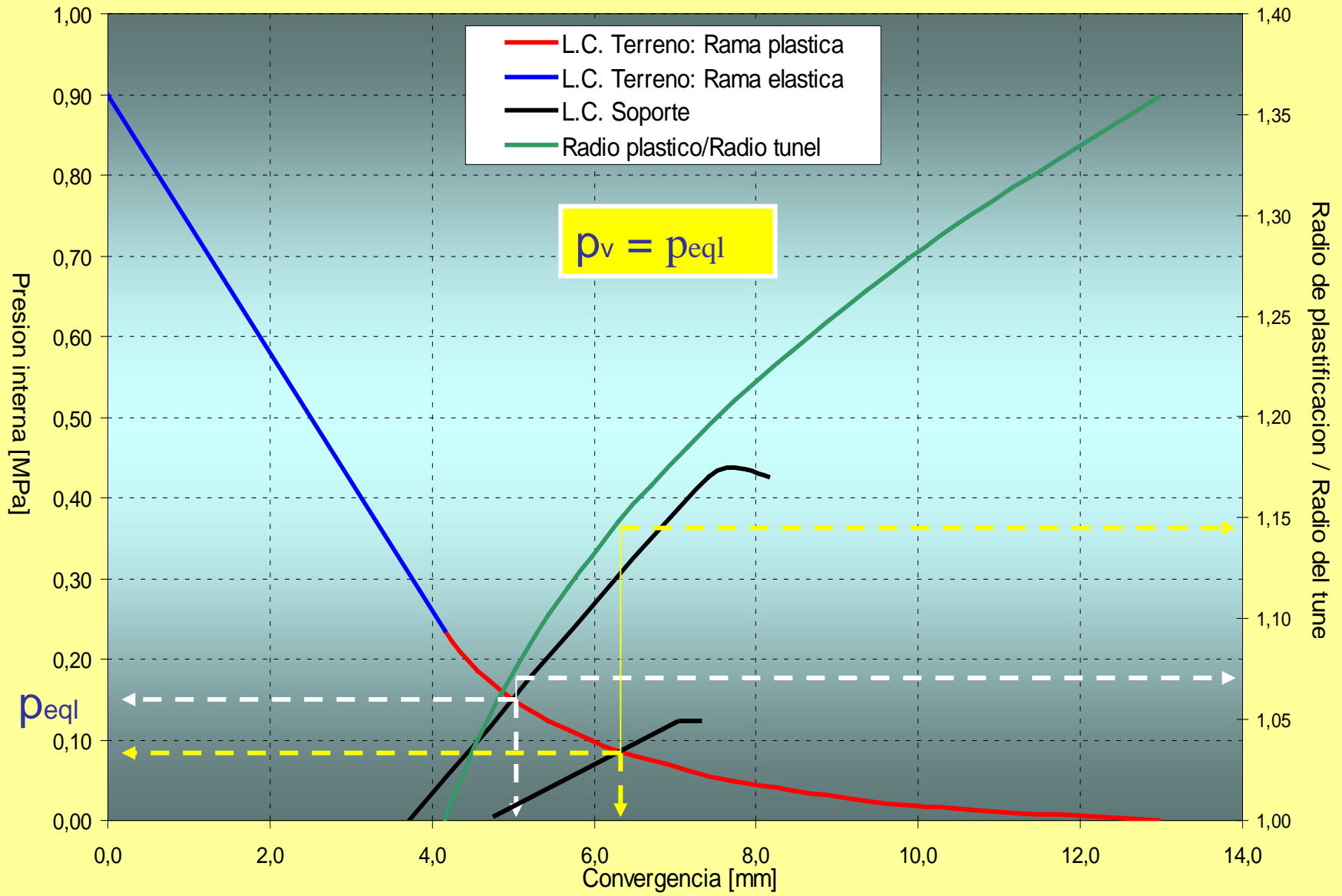

# Clases de Comportamiento de la Excavación

<i>Lunardi</i>		<b>I</b>	<b>II</b>		<b>III</b>	
<i>Hoek y Marinós</i>		<b>A</b>	<b>B</b>	<b>C</b>	<b>D</b>	<b>E</b>
<i>Russo y Otros</i>		a-b	c	d	e	f
Secciones <b>Profundas</b>	<i>Convergencia</i>	$\varepsilon < 1\%$ $\delta < 0.5\%$	$(1\% < \varepsilon < 2.5\%) \delta < 0.5\%$	$(2.5\% < \varepsilon < 5\%)$ $(0.5\% < \delta < 1\%)$	$(5\% < \varepsilon < 10\%) \delta > 1\%$	$\varepsilon > 10\%$ $\delta > 1\%$
	<i>Índice de Competencia</i>	$IC > 0.45$	$(0.45 > IC > 0.3)$	$(0.3 > IC > 0.2)$	$(0.2 > IC > 0.15)$	$IC < 0.15$
	<i>Radio Plástico</i>	$R_p/R_o = 1$	$(1 < R_p/R_o < 2)$	$(2 < R_p/R_o < 4)$	$R_p/R_o > 4$	$R_p/R_o \gg 4$
Secciones <b>Intermedias</b>	<b>GSI</b> <i>(RMR-Q-RSR-Rmi)</i>	$GSI > 70$	$70 > GSI > 50$	$50 > GSI > 25$	$25 > GSI > 15$	$GSI < 15$
Secciones <b>Superficiales</b>	<i>(GSI-RMR-Q-RSR-Rmi)</i> <i>Geometría Sección</i> <i>Estabilidad Frente</i>	<b>GSI &gt; 50</b>			<b>GSI &lt; 50</b>	

# ***Cómo se puede controlar una excavación crítica?***

***Complementando los soportes con intervenciones especiales:***

- ◆ **Parcializando la sección**
- ◆ **Pre-consolidando el medio**
  - **Inyecciones de cemento o silicatos u otros productos**
  - **Inyecciones jet grouting o congelamiento del terreno**
- ◆ **Pre-soportando la excavación**
  - **Pernos o tubos en avance (spiling o marciavanti)**
  - **Arcos tronco-cónicos de concreto en un pre-corte**
  - **Arcos de micropilotes (forepoling) o de jet grouting**
- ◆ **Controlando (conteniéndolo o estabilizándolo) el frente**



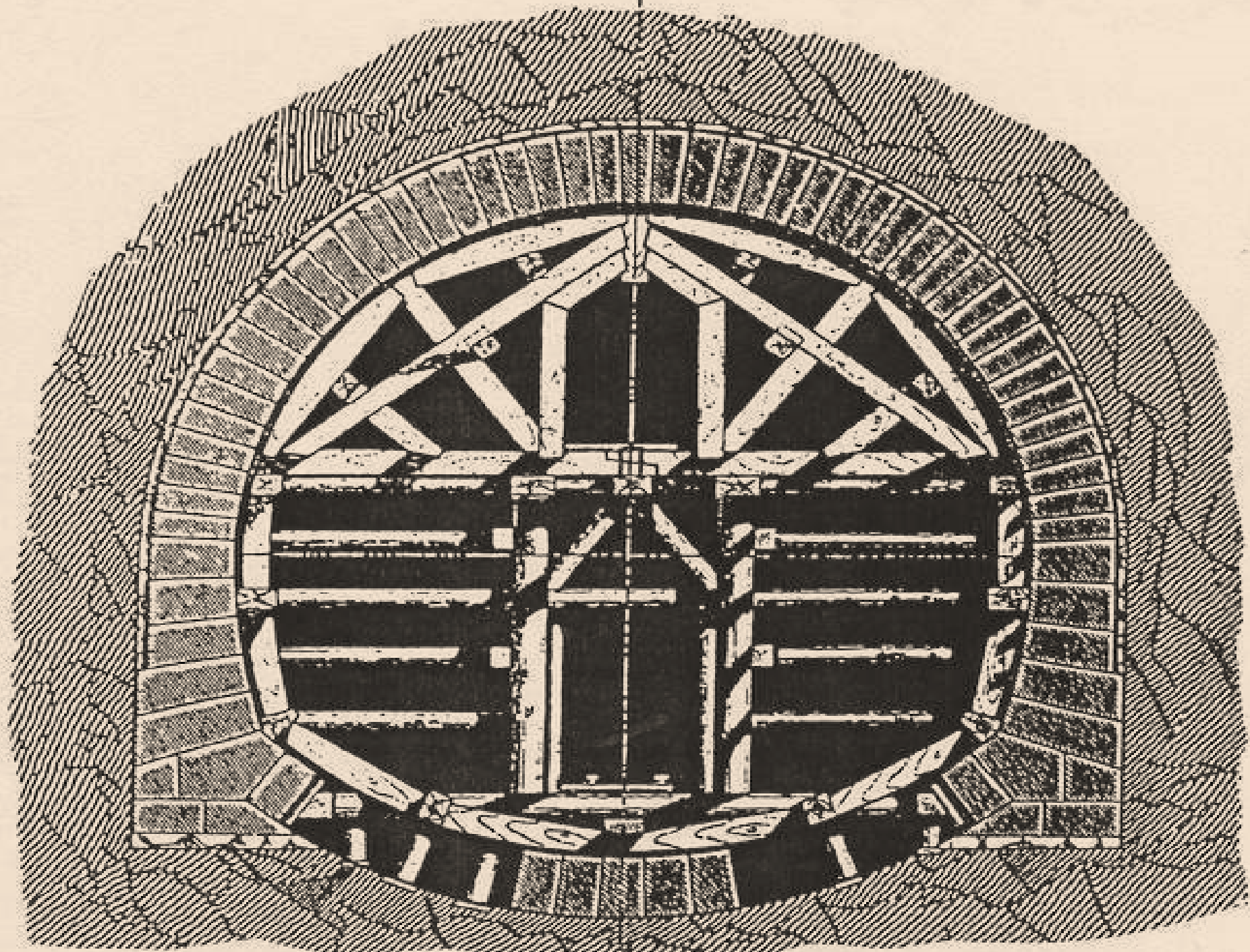



# Construcción de la Ferrovía Bologna-Firenze

1856-1864

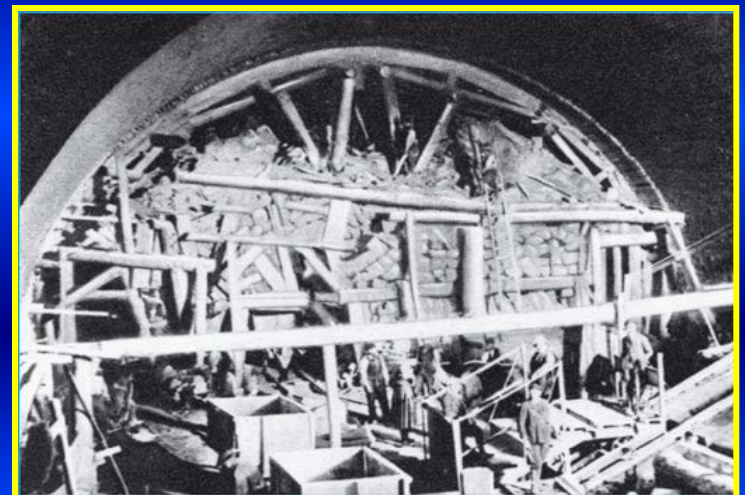



**Parcializacion de la seccion**

Full-face excavation

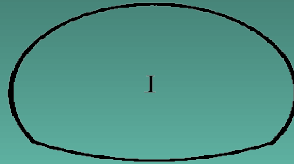

Short bench

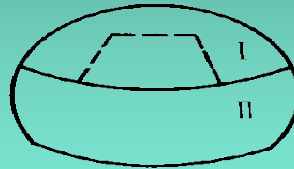

Mini-bench

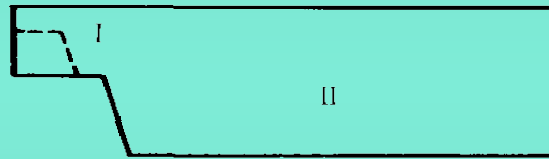
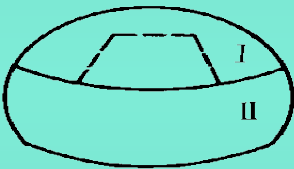

Multiple-stage bench

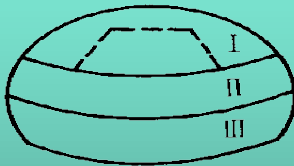

Side pilot

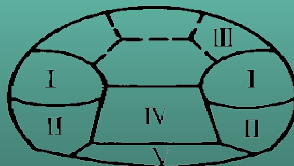

***Típica moderna excavación a sección parcializada en terrenos muy inestables***



# Inyecciones de consolidación

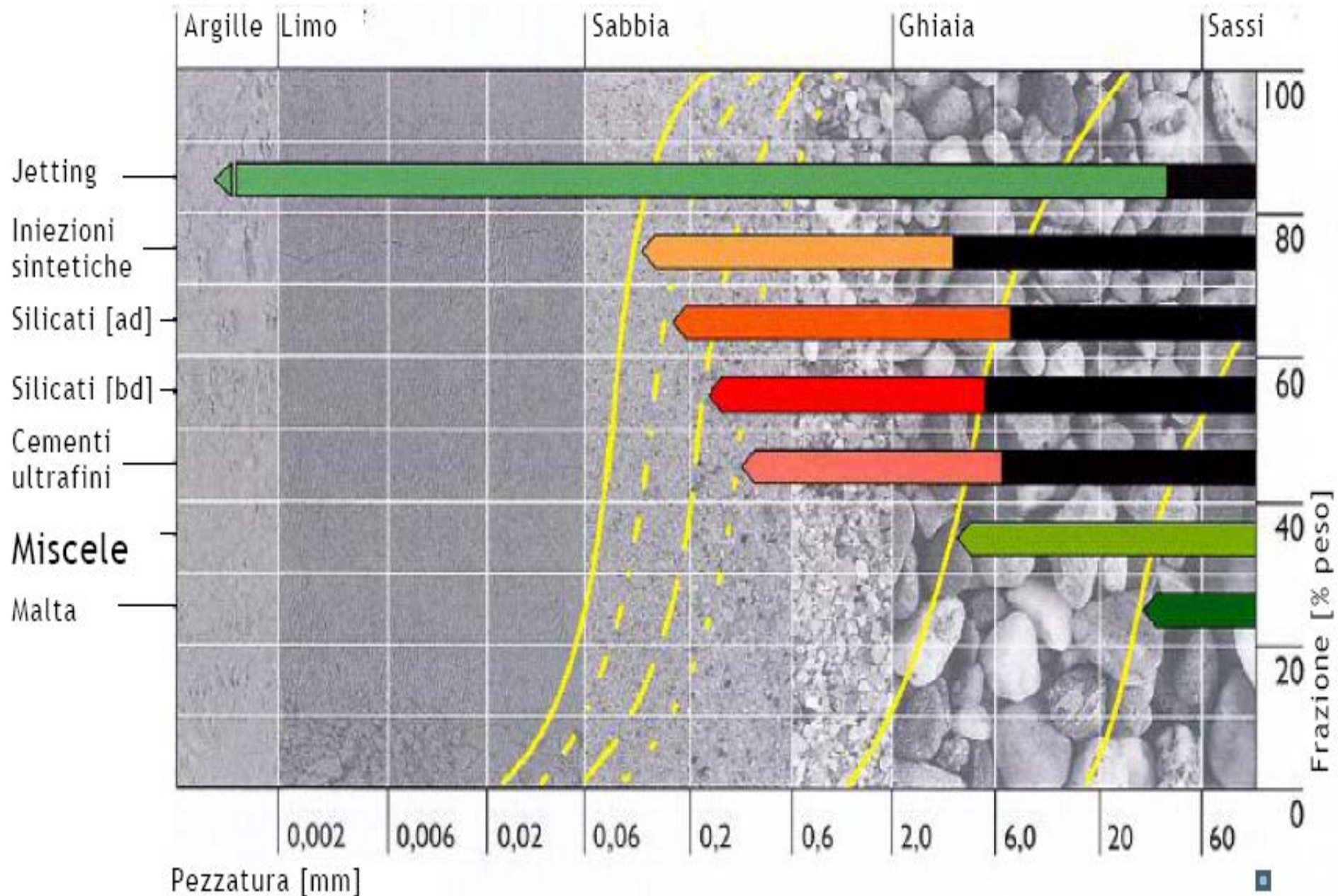

# *Inyecciones de consolidación*

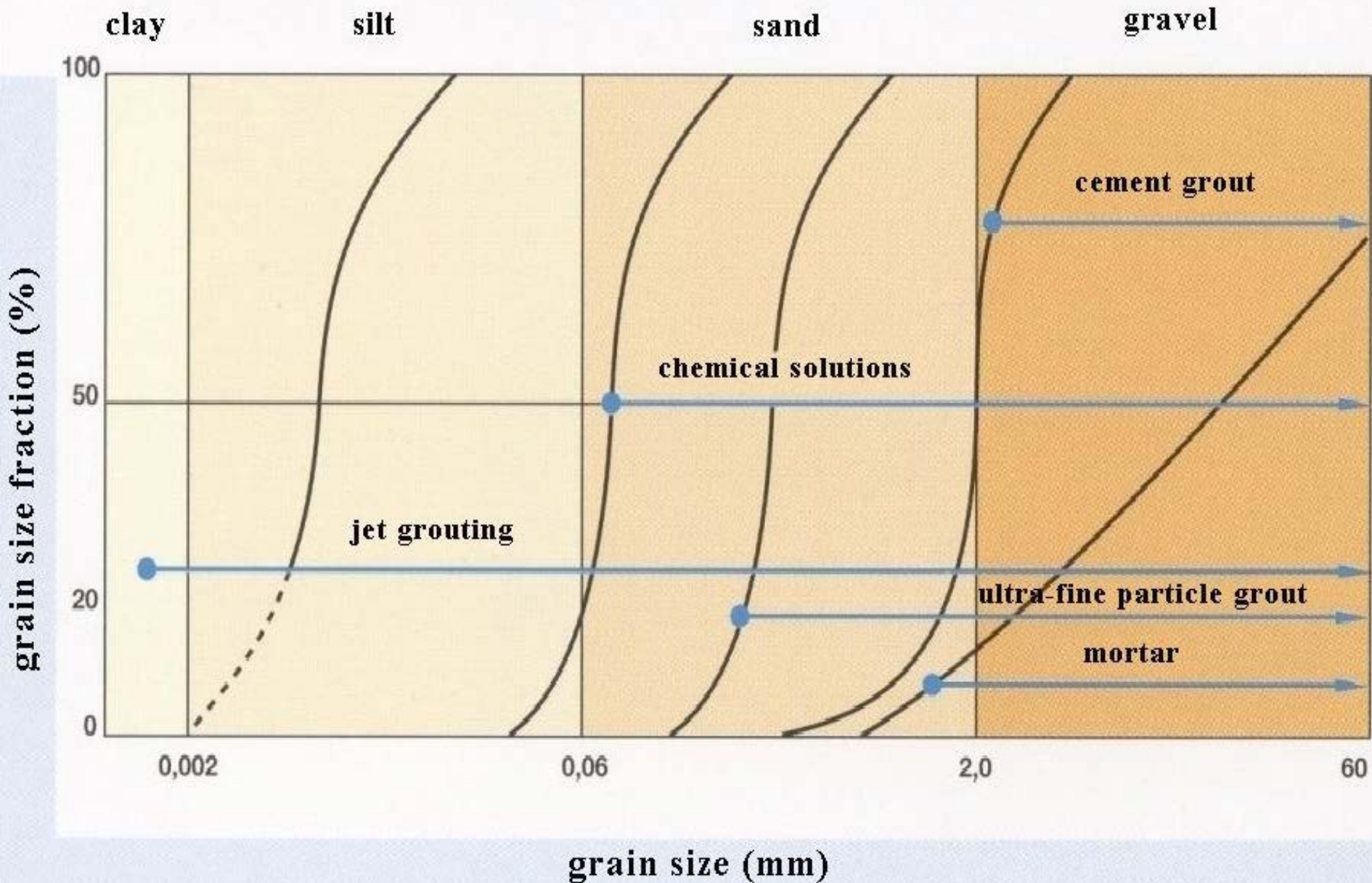

# *Inyecciones de consolidación*



# *Inyecciones de consolidación*



# Inyecciones de consolidación

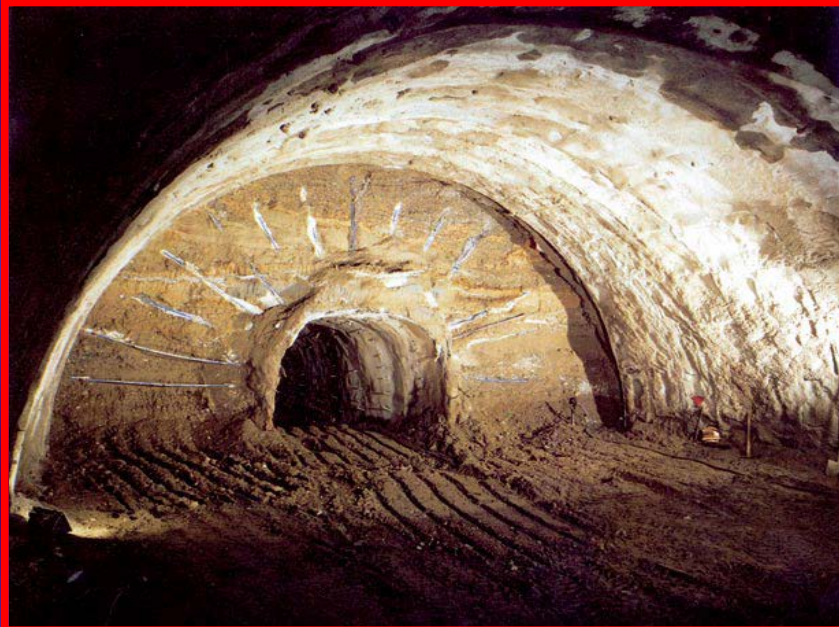
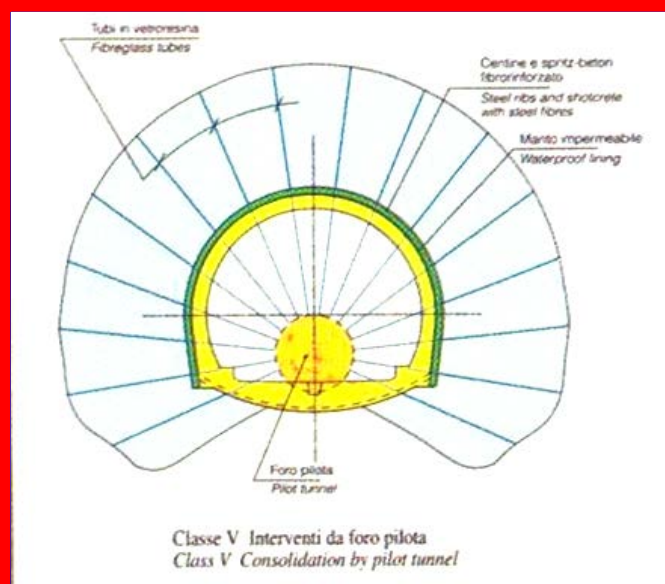

# *Inyecciones de consolidación*





# *Jet grouting technology*

**Drilling with  
water support**

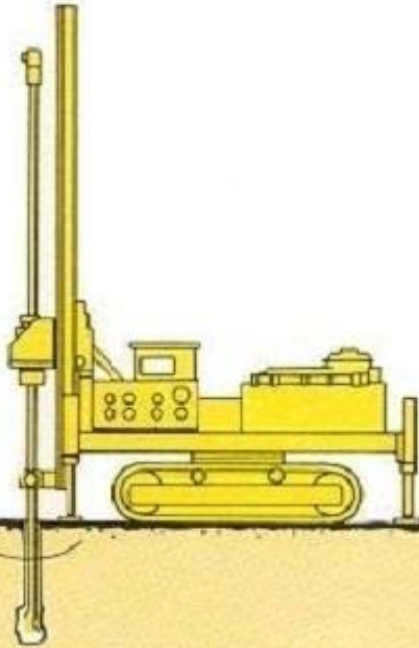

**Starting high-  
pressure-grouting**

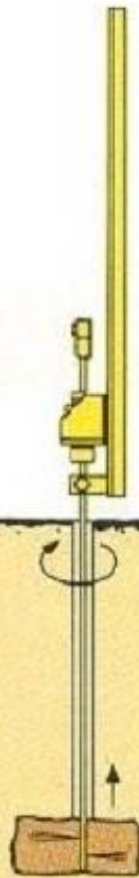

**Finished  
grout structure**



**Repeating with  
interlocking**

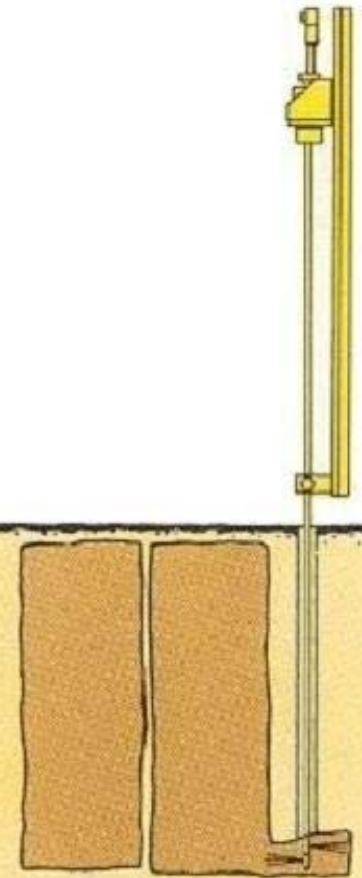

**Execution of a jet grout body**

# *Jet grouting technology*

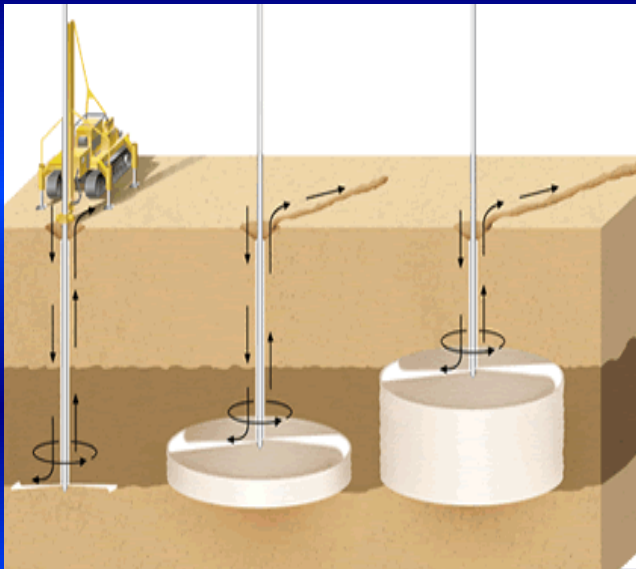
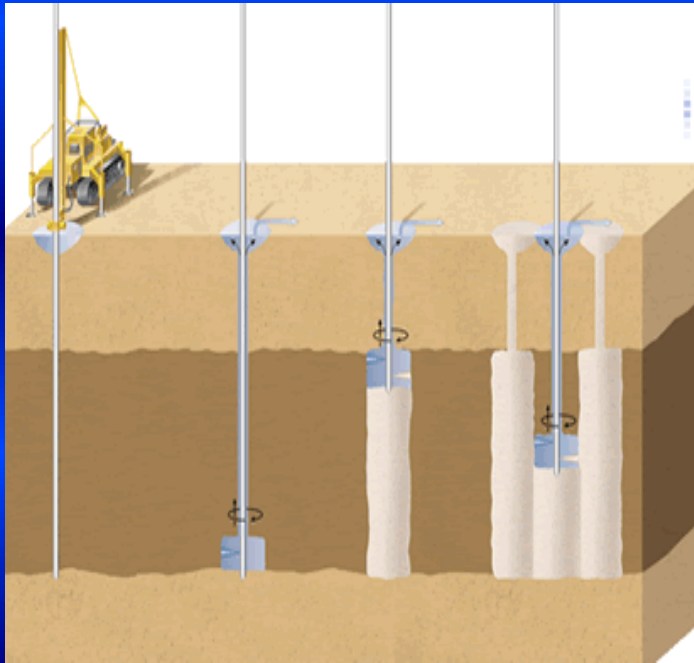

# *Jet grouting technology*



# Jet grouting technology

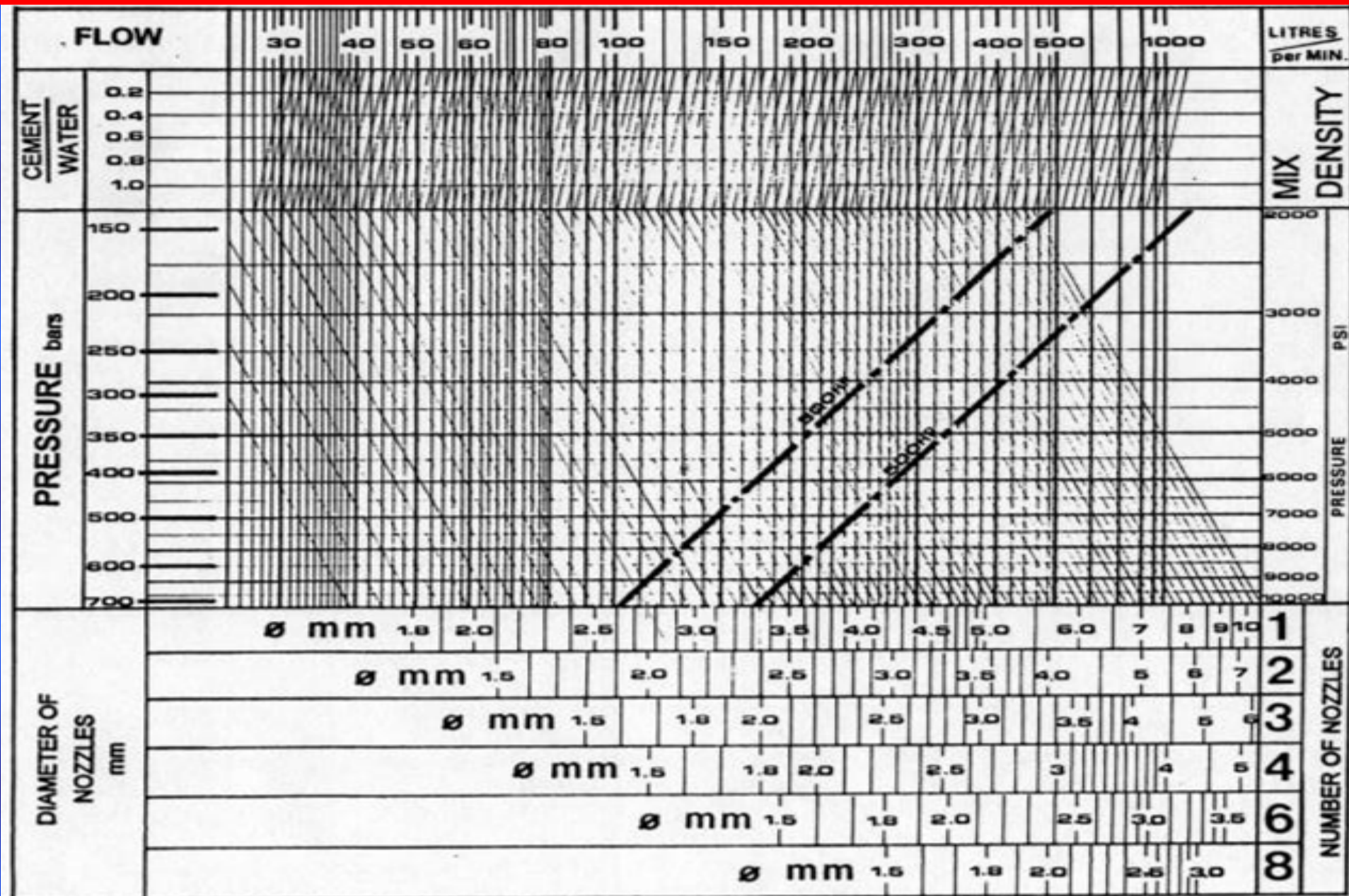

# Consolidacion mediante inyecciones de jet grouting

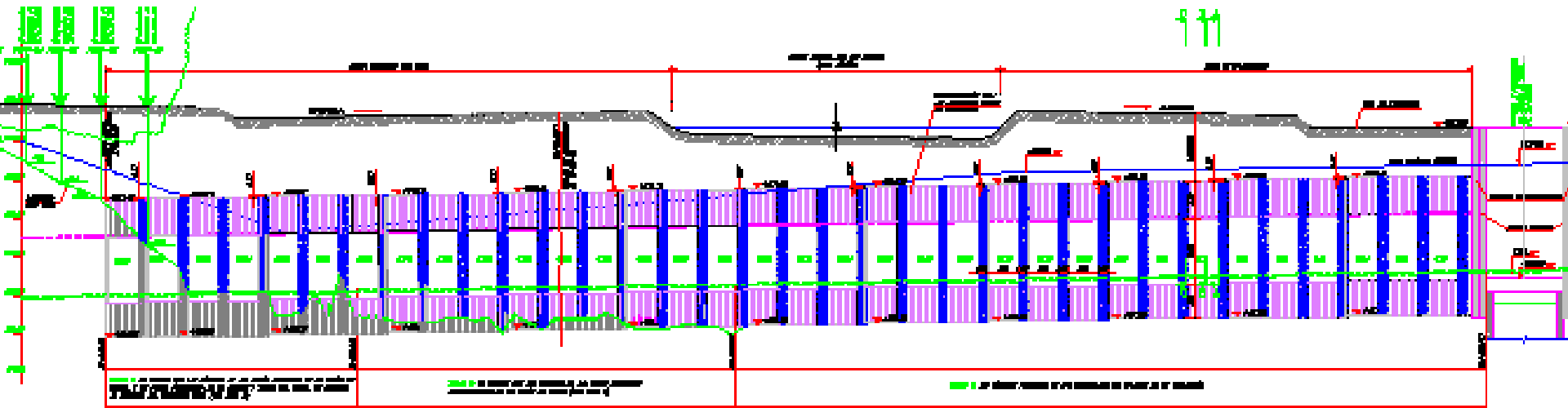

SECCION TRANSVERSAL

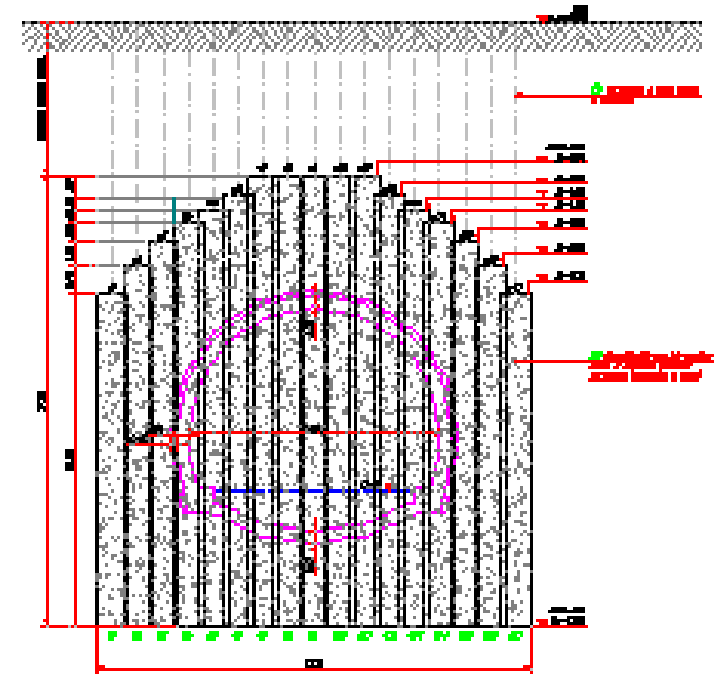

SECCION TRANSVERSAL

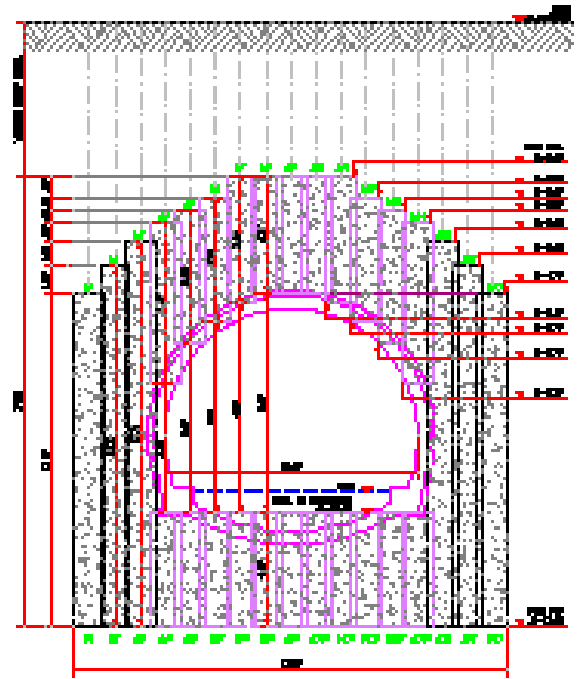

SECCION TRANSVERSAL

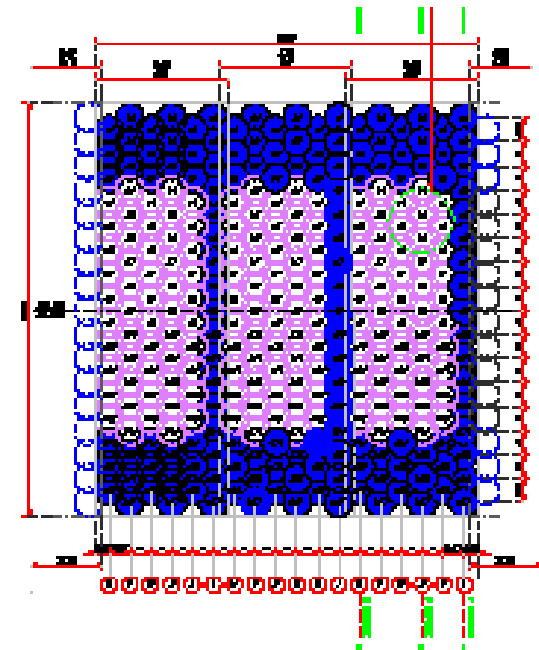

Túnel Bábula

# Consolidación mediante inyecciones de jet grouting

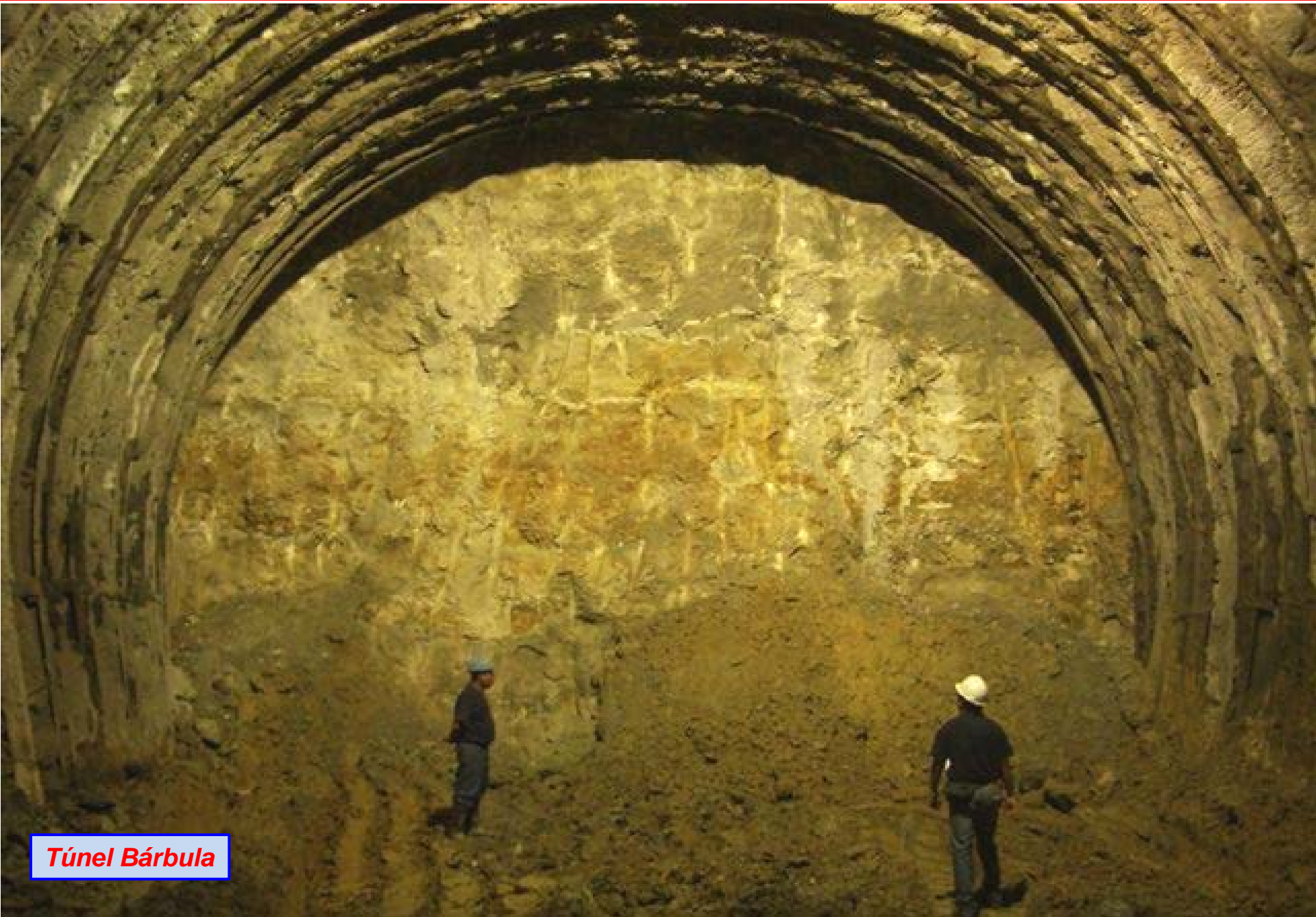

**Túnel Bárbula**

# ***CONSOLIDACION MEDIANTE CONGELAMIENTO***

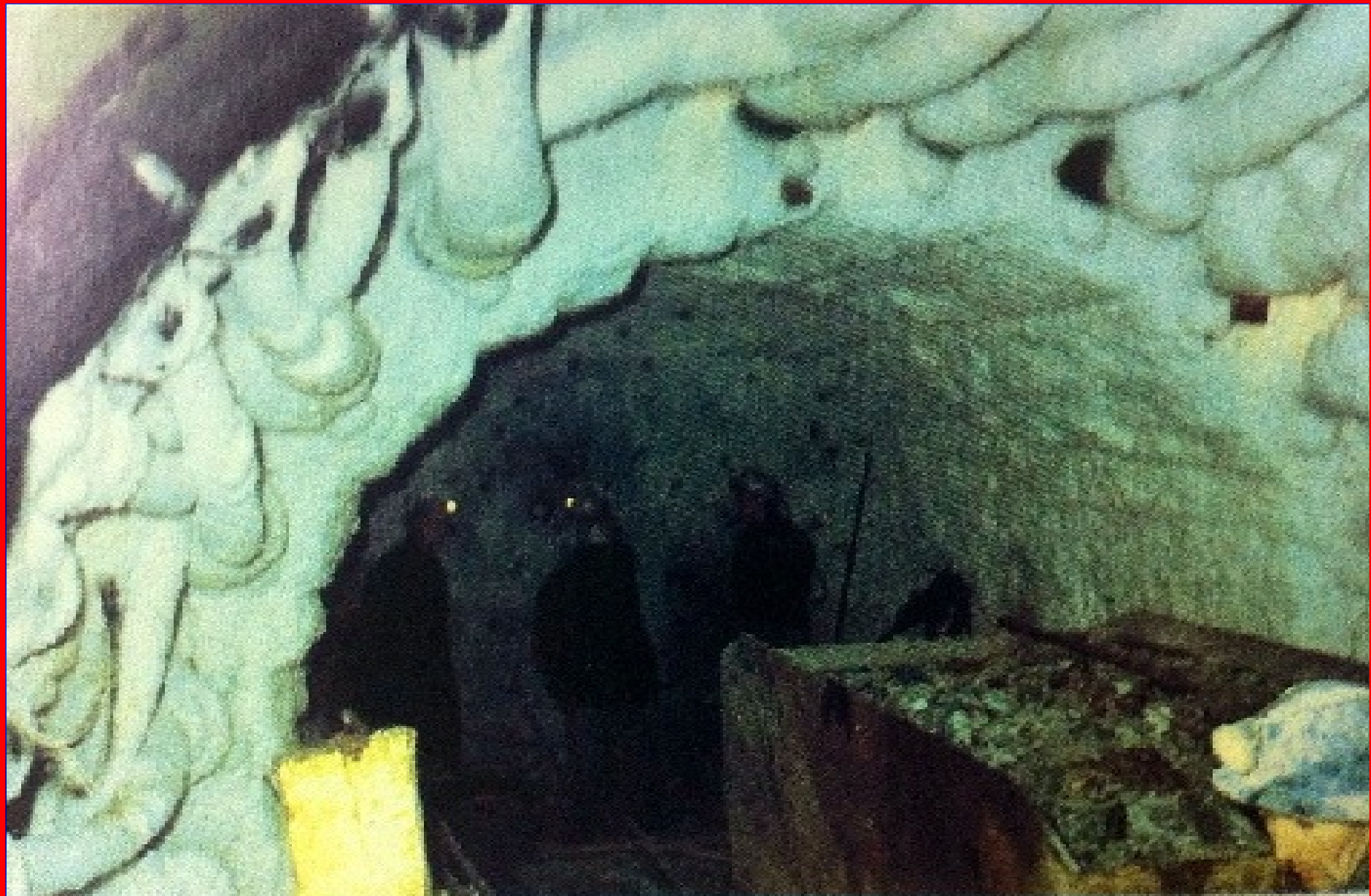

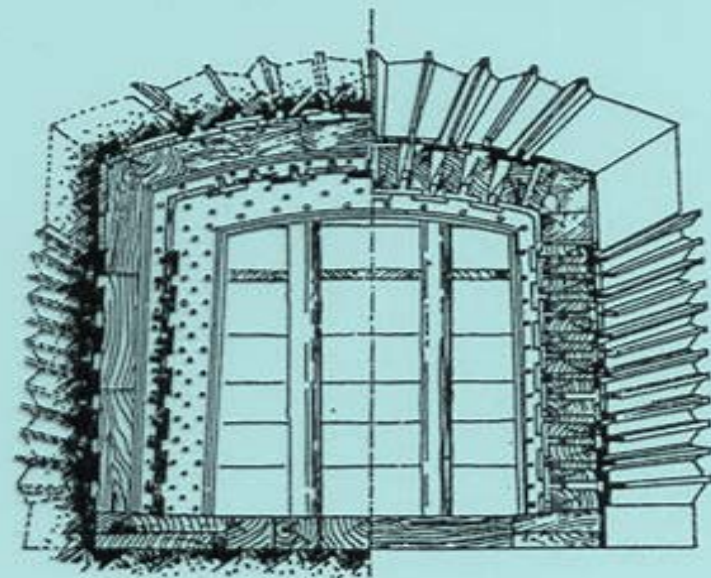
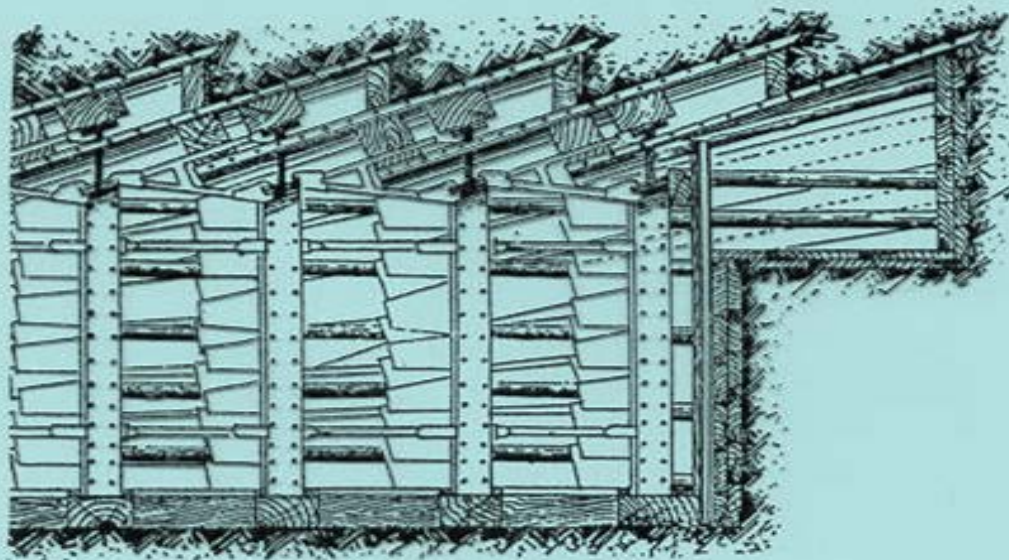

***PRESOPORTE: marchavanti***

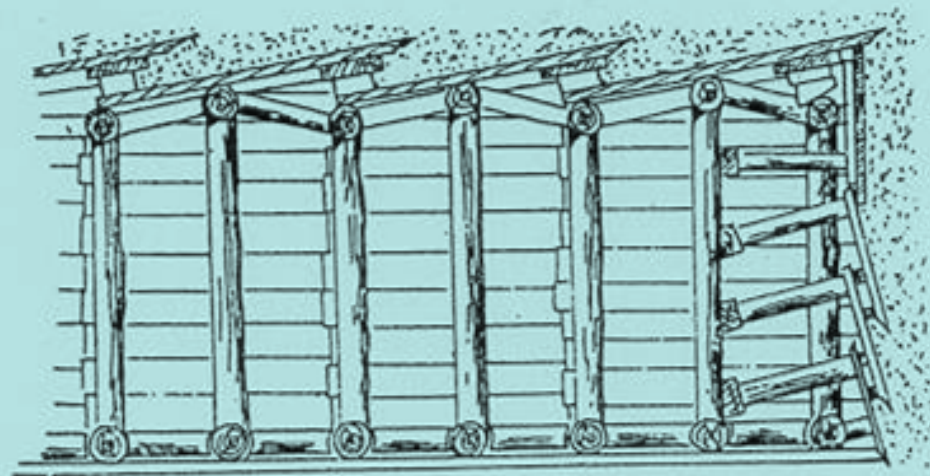
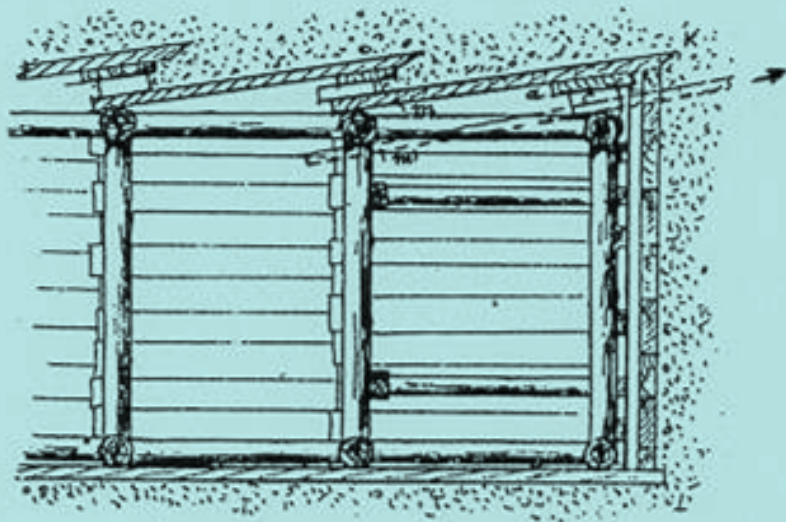



# ***PRESOPORTE: spiling o spiles***

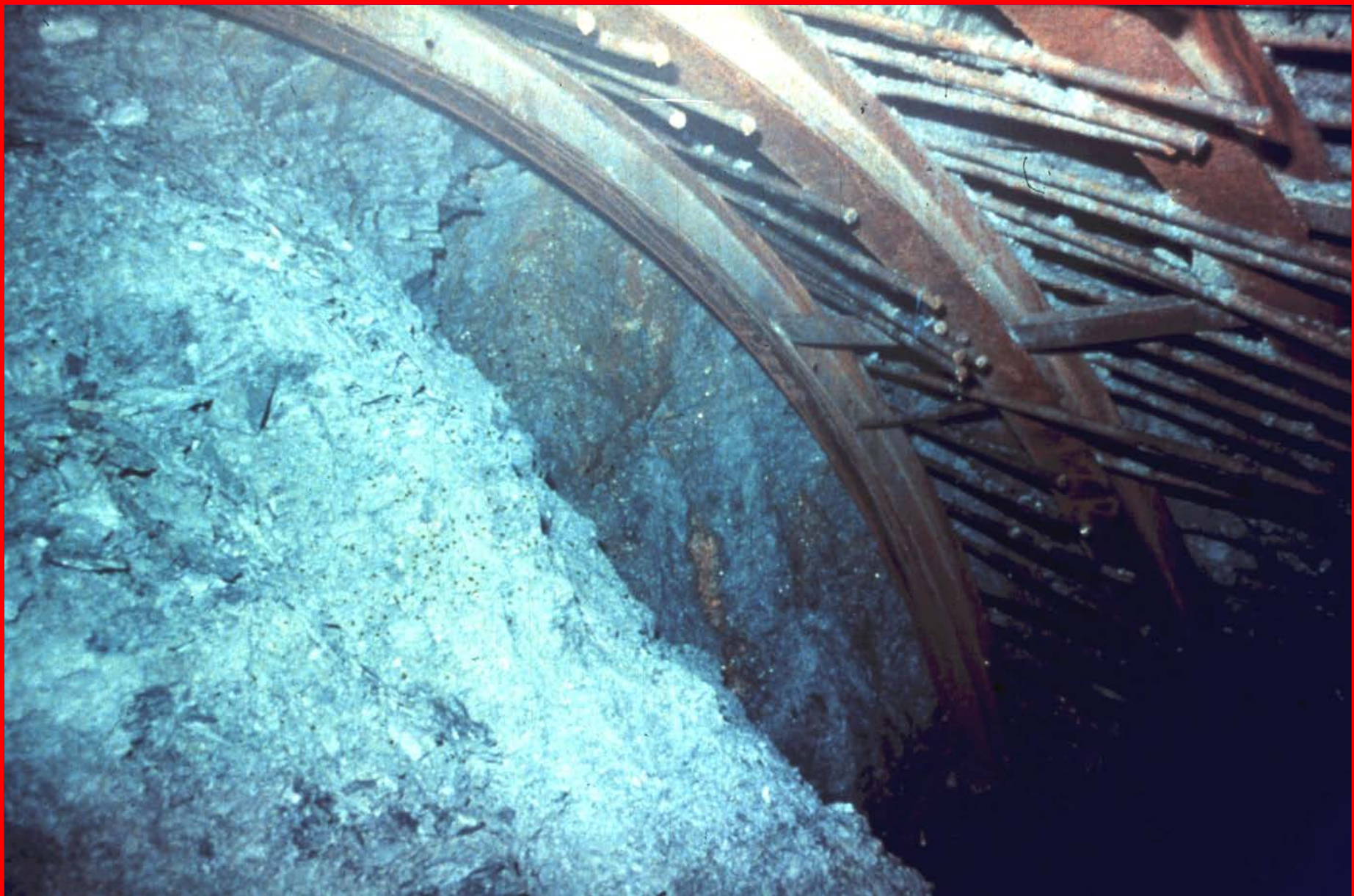

# ***PRESOPORTE: pre-cut shells***

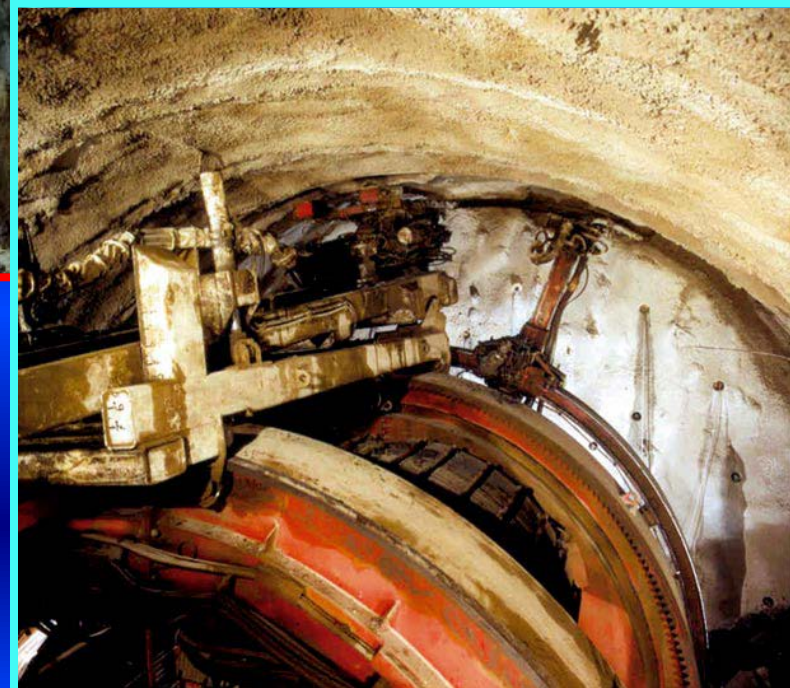

# ***PRESOPORTE: forepoling***

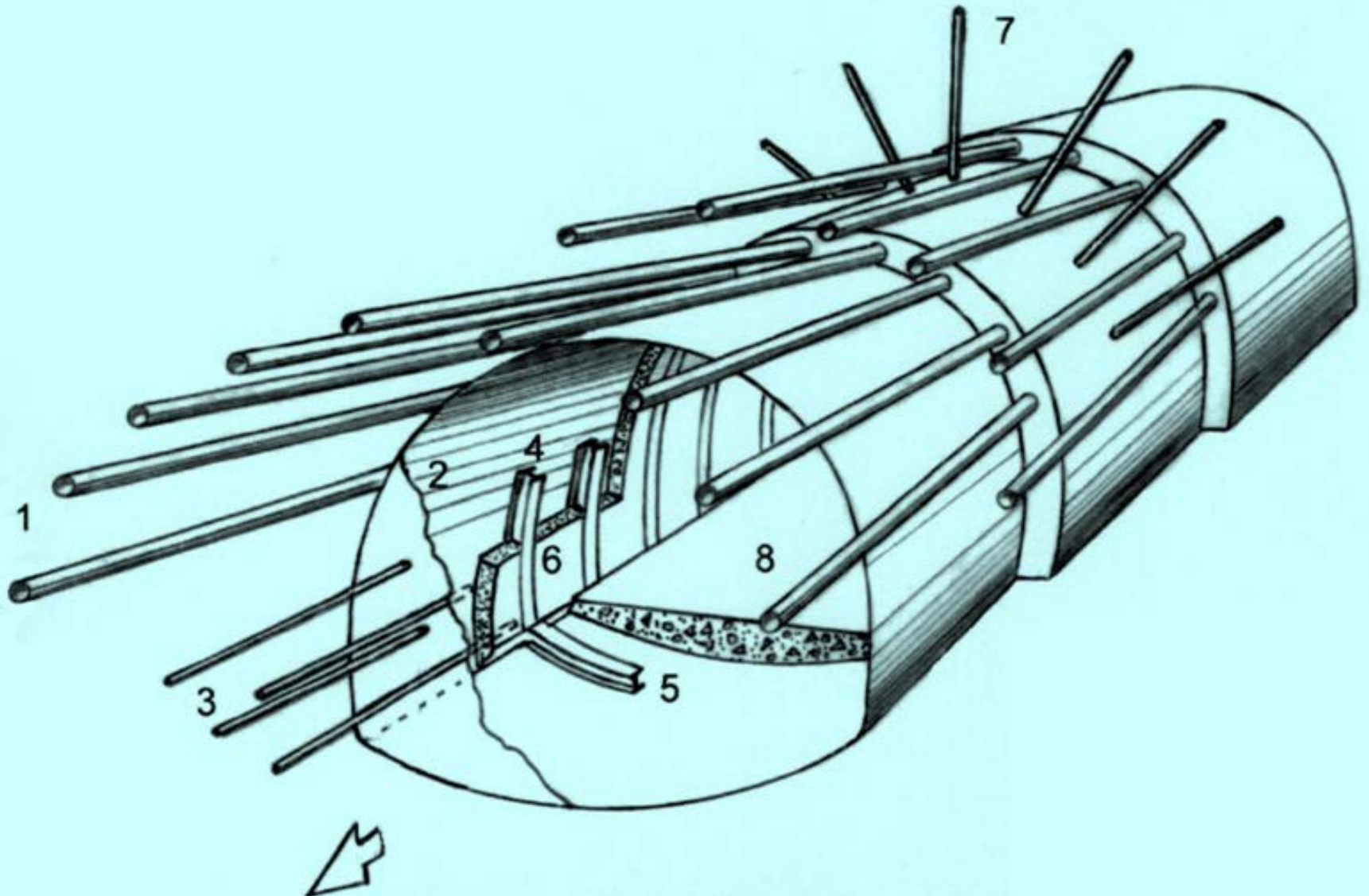

# PRESOPORTE: forepoling

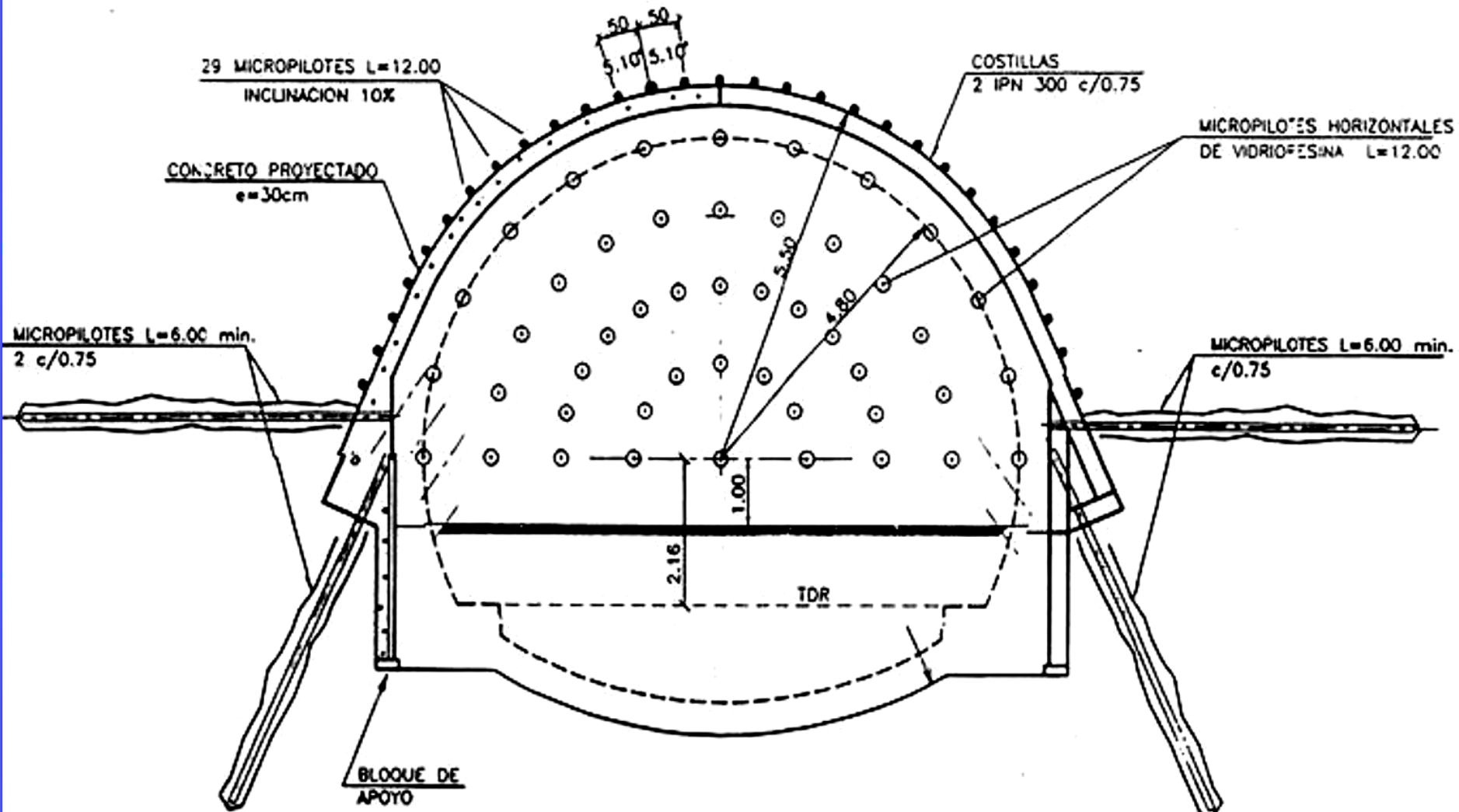

# ***PRESOPORTE: forepoling***

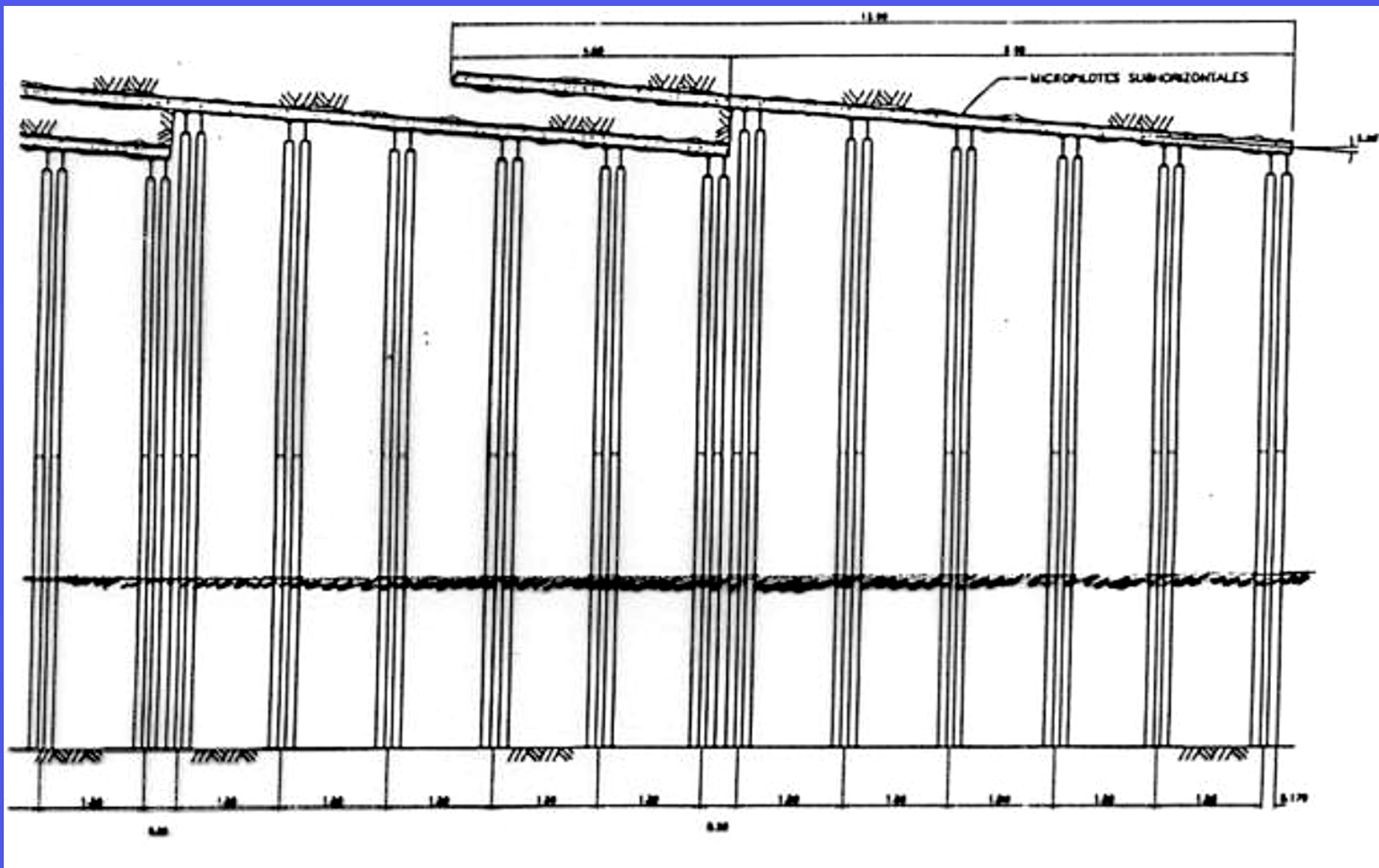















# TÚNEL PRESOPORTADO CON FOREPOLING (Arcos troncocónicos de micropilotes)





# PRESOPORTE: forepoling

## CONSOLIDAMENTO DELLA CALOTTA CON INFILAGGI SEZIONE DEL FRONTE (INIZIO VOLATA)

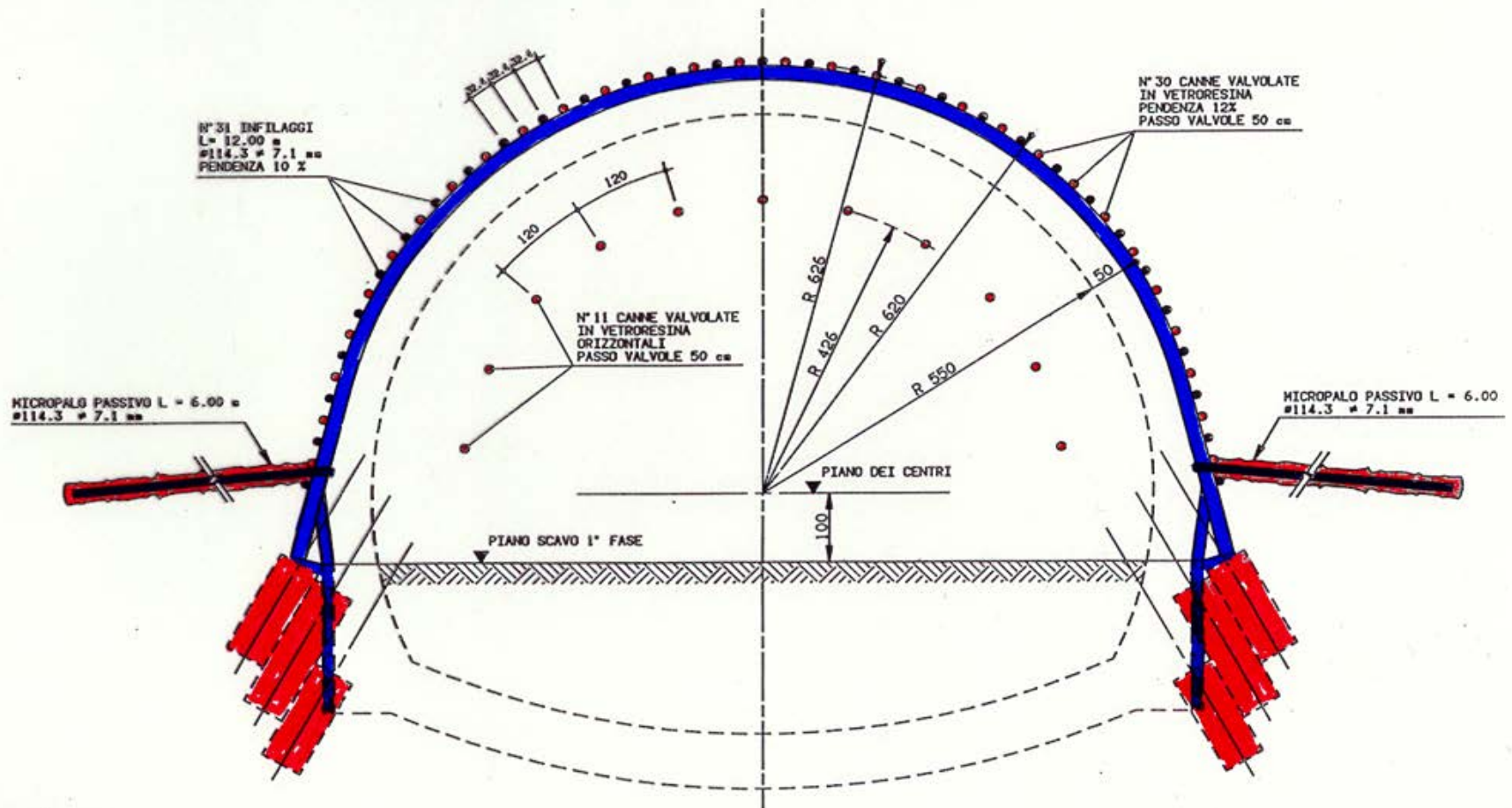

# *Presoporte con Jet grouting*

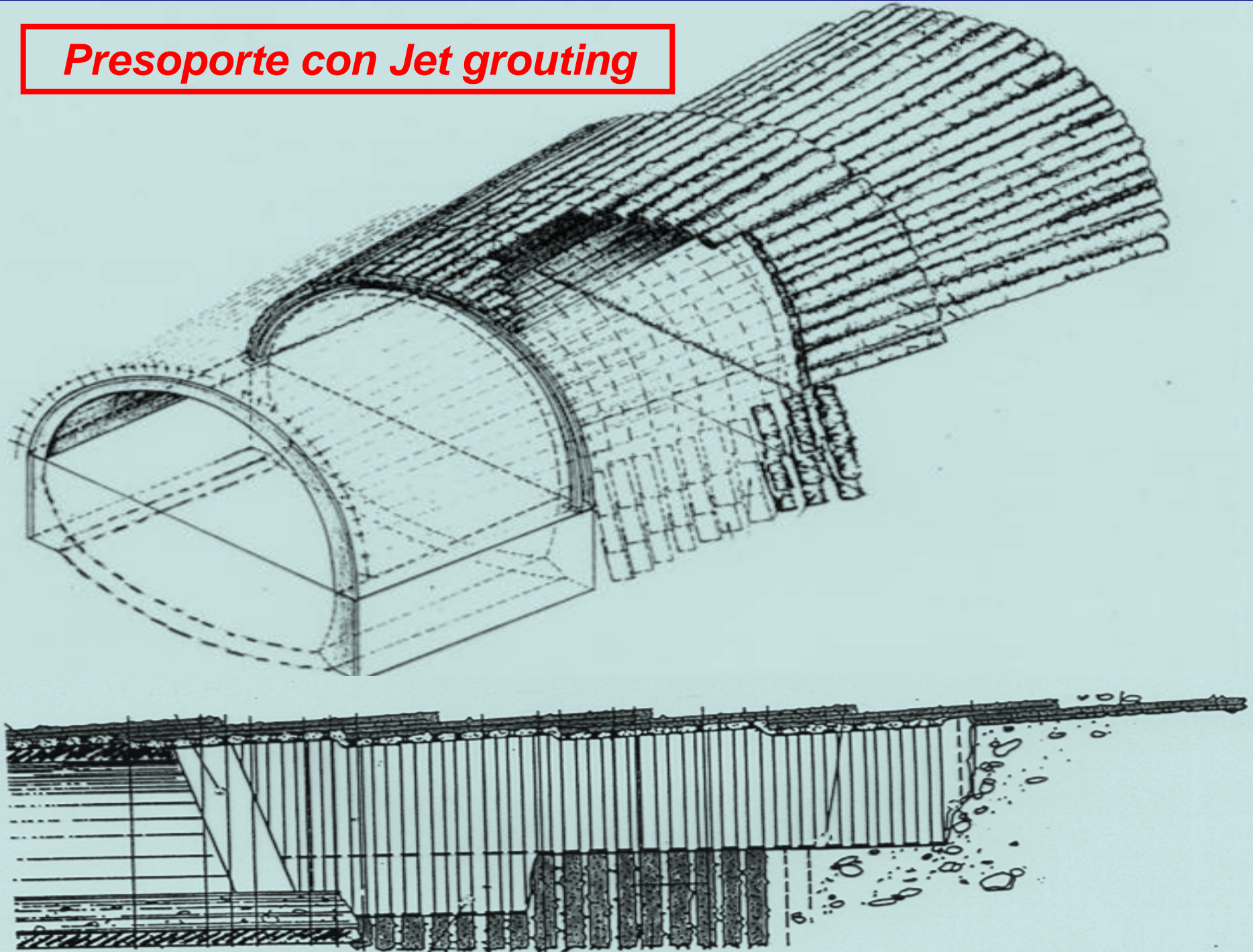

# Presoporte con jet grouting

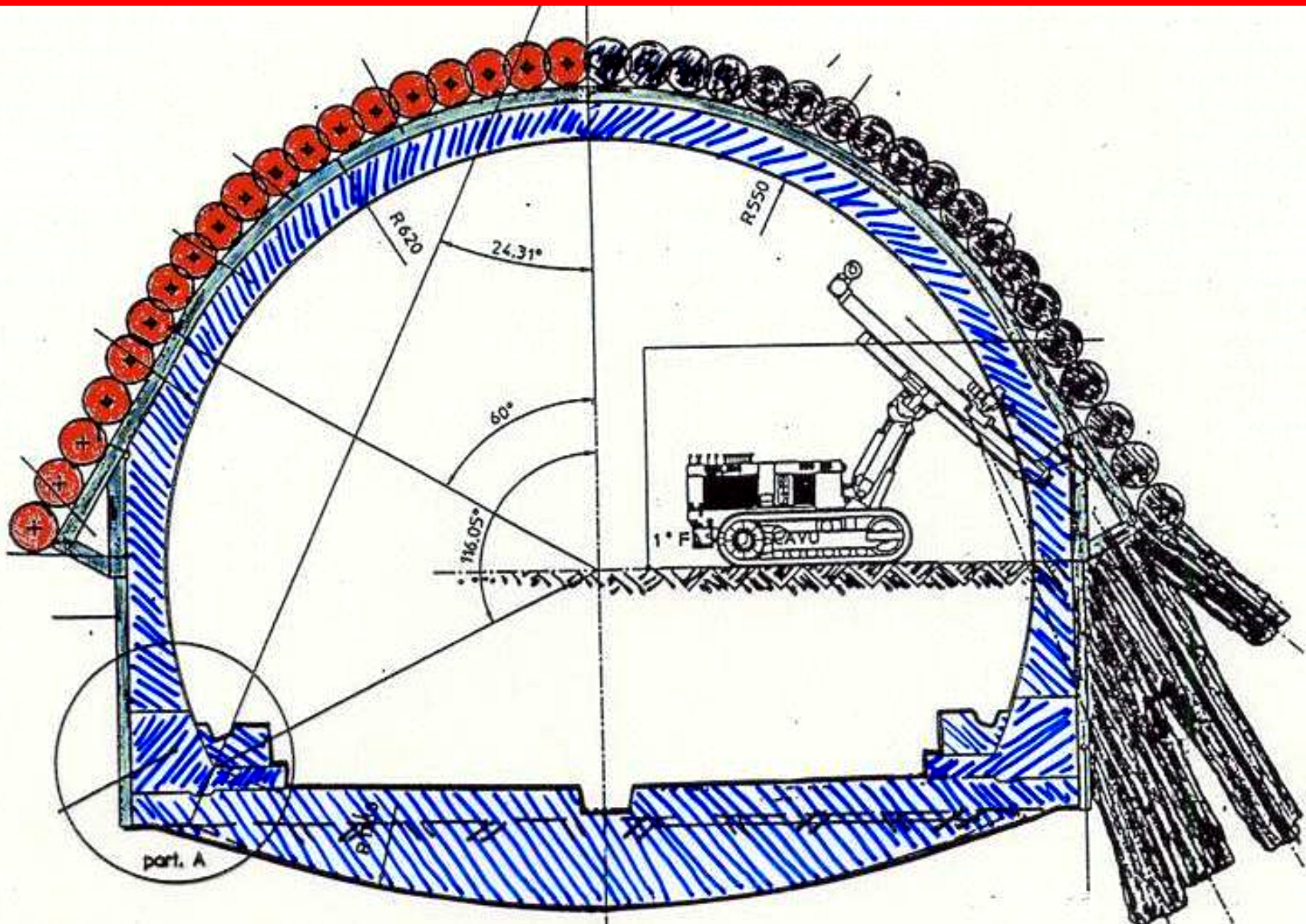



# *Presoporte con jet grouting*

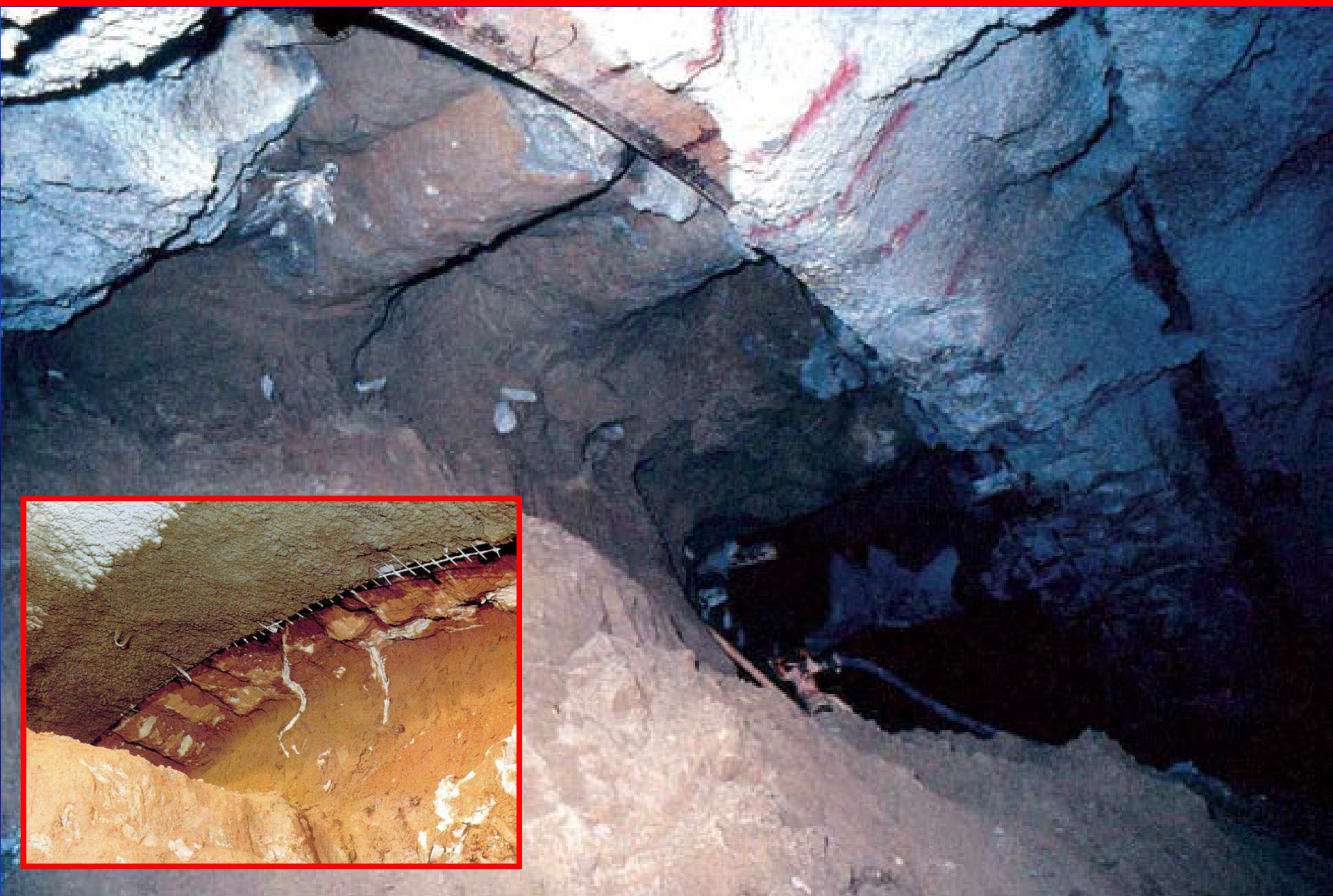



# Control de la excavación estabilizando el frente

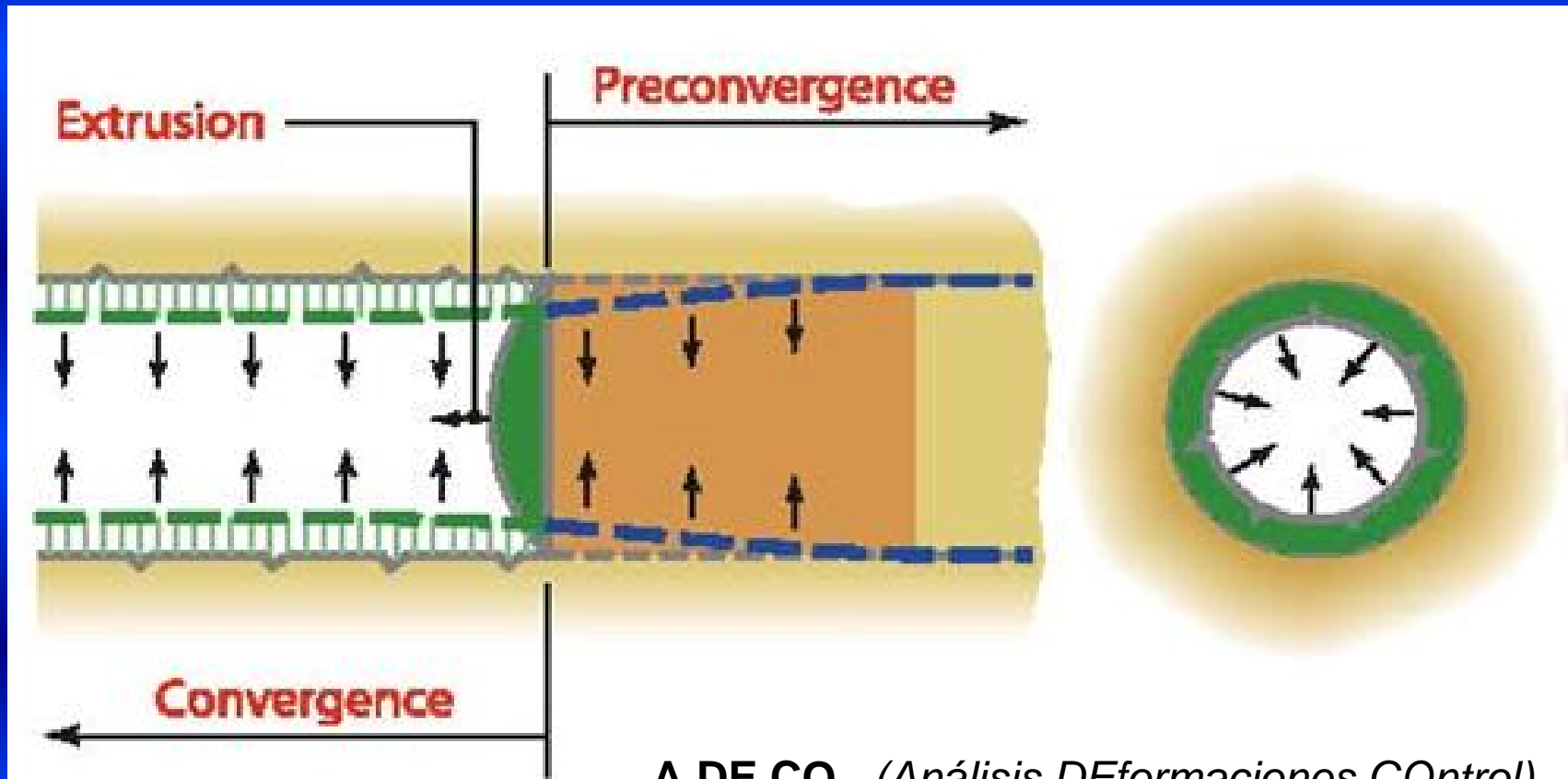
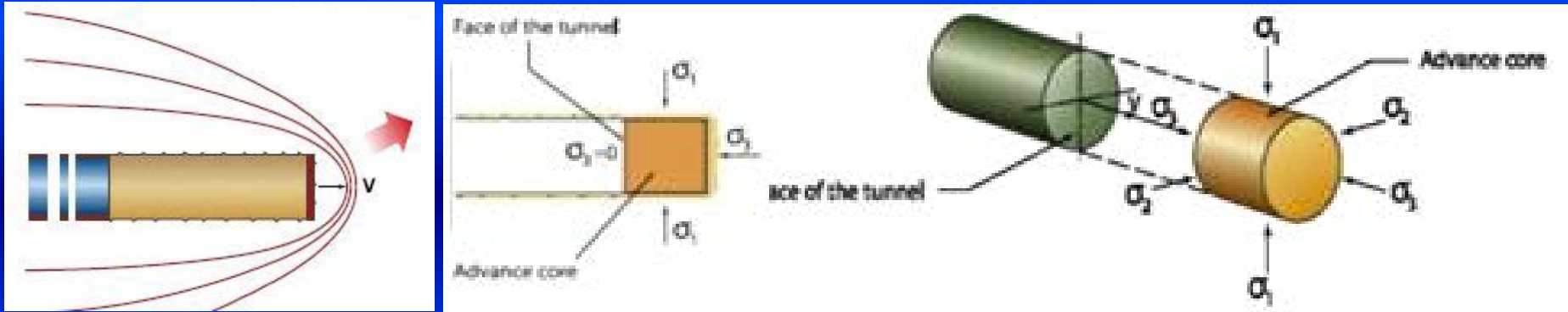

A.DE.CO. (Análisis DEformaciones COntrol)

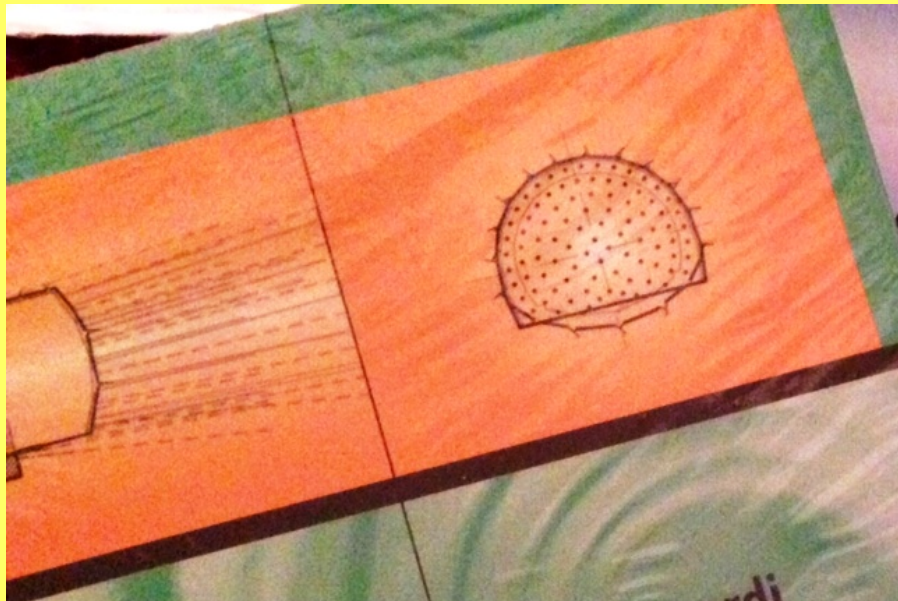

Pietro Lunardi

# Design and Construction of Tunnels

Analysis of Controlled Deformation in Rock and Soils (ADECO-RS)

Design and Construction of Tunnels  
Analysis of Controlled Deformation in Rock and Soils (ADECO-RS)  
隧道设计与施工  
岩土控制变形分析法  
(ADECO-RS)

Analisi delle deformazioni  
nelle rocce e nei suoli

# Progetto e costruzione di gallerie

PIETRO LUNARDI

Biblioteca Tecnica Hoepli

# ***Micropilotes de vitroresina***

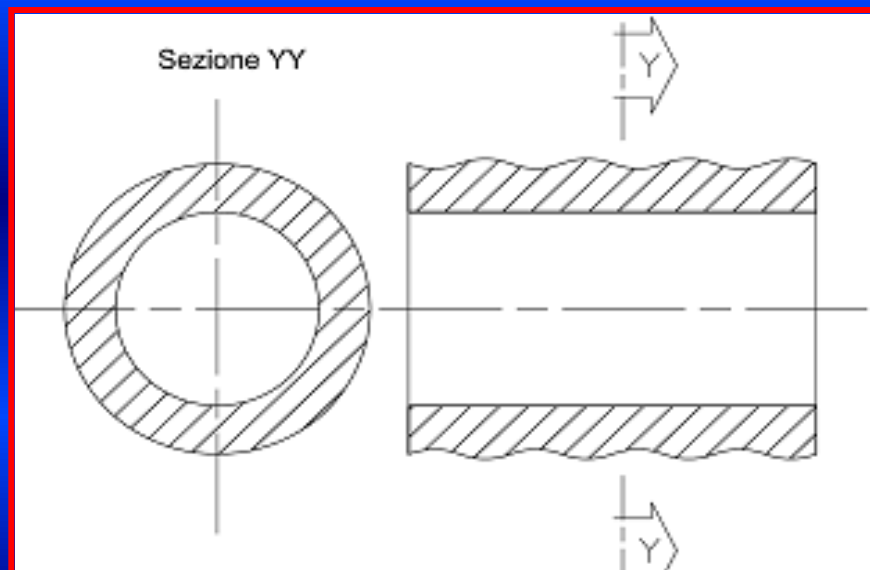

# ***Micropilotes de vitroresína***

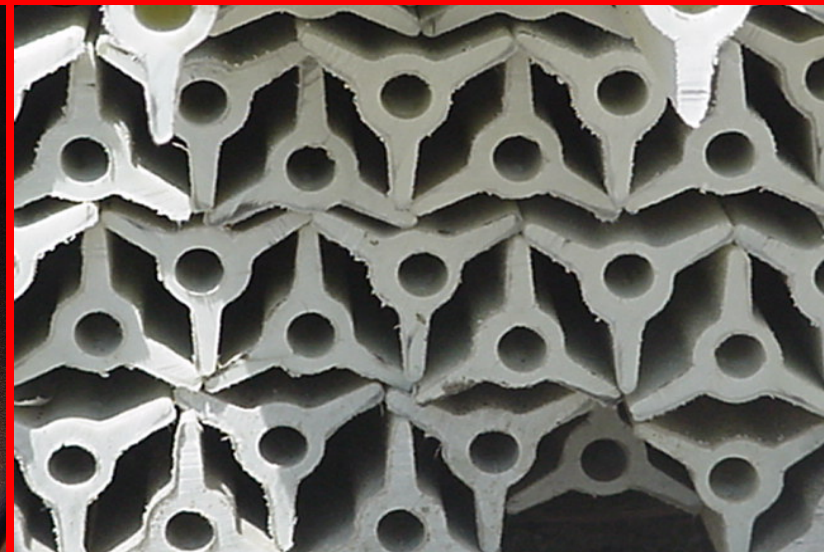

# ***Micropilotes de vitroresína***



# ***Micropilotes de vitroresína***

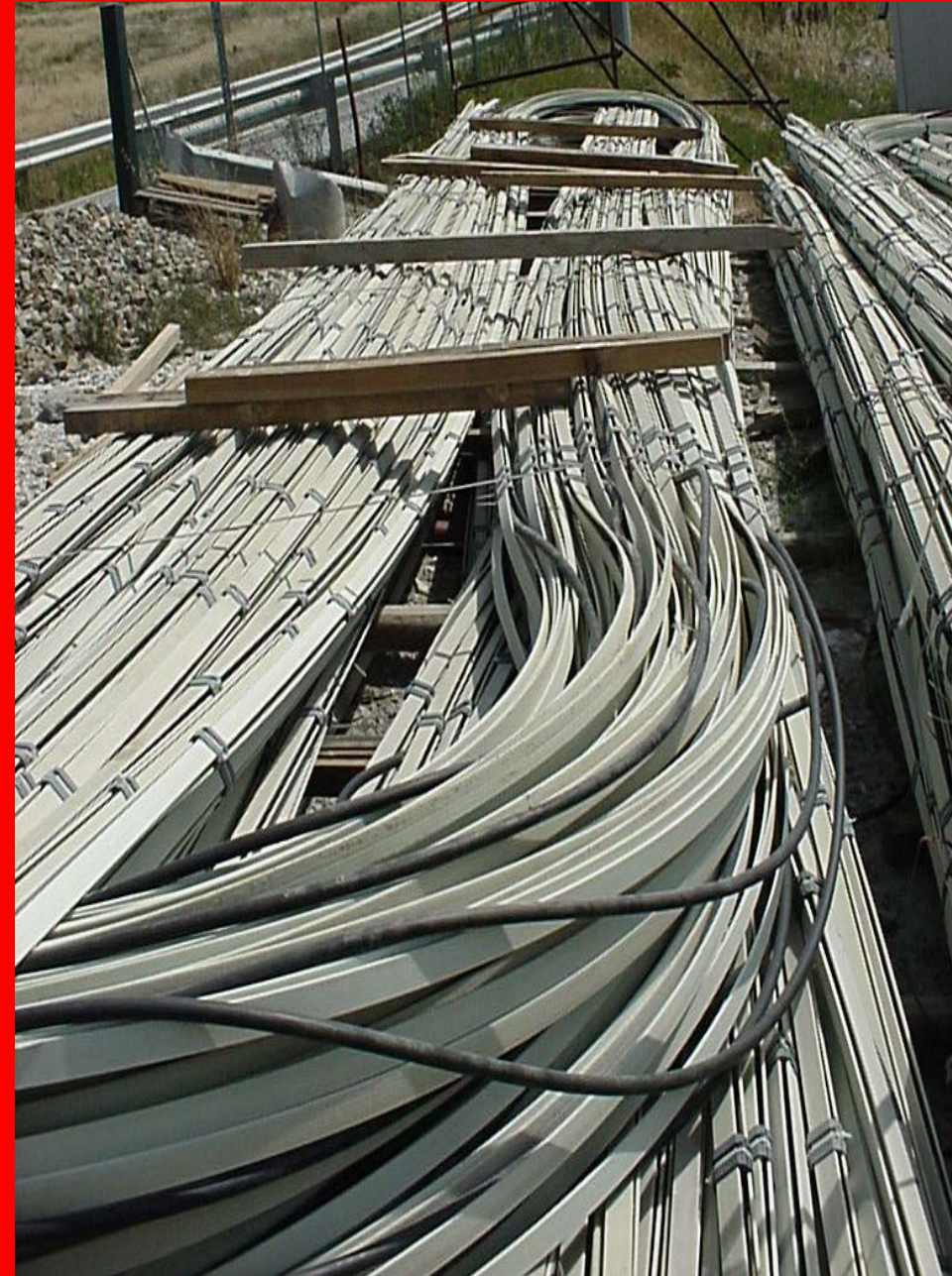



# Micropilotes de vitroresina

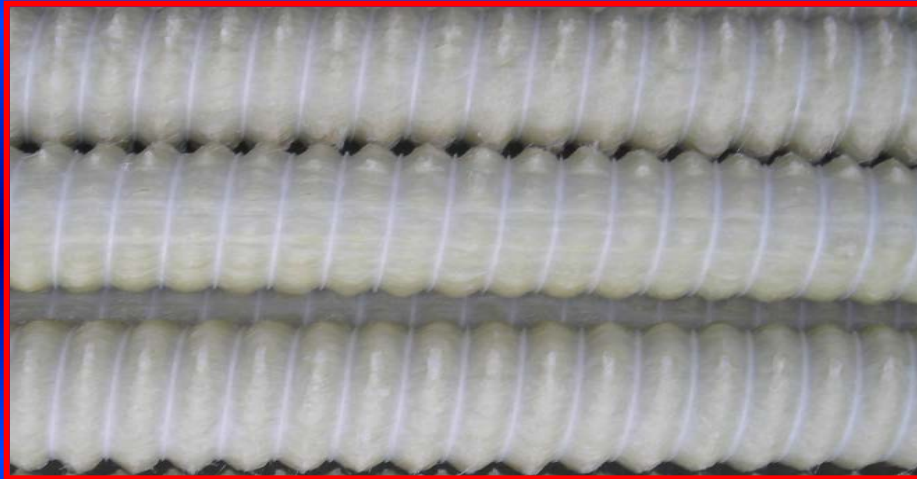

## TECHNICAL SCHEDULE

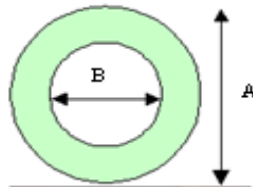

### Technical specifications

- material:
  - resin/fibre: polyester/glass fibre
  - density: 1.81 g/dm<sup>3</sup>
  - glass content: min. 50% ( in weight )
- mechanical characteristics:
  - traction resistance: 450-1100 MPa
  - elongation to breakage: 2%
  - elastic module: 24000-25000 MPa
  - cutting resistance: 70-200 MPa

A* mm	B** mm
60	40

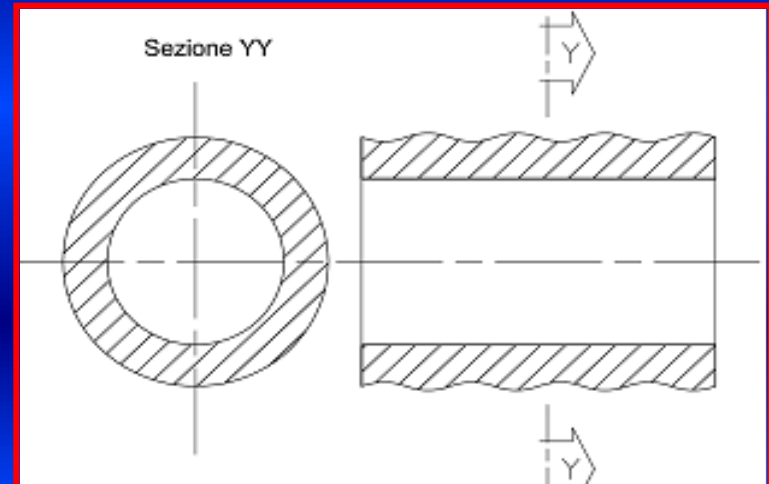

# ***Micropilotes de vitroresina***



# Micropilotes de vitroresina



## TECHNICAL SCHEDULE

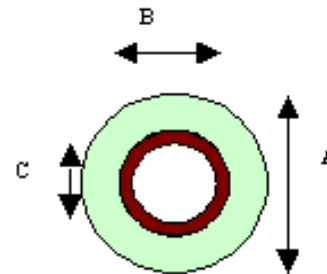

### Technical specifications

- materials
  - resin/fibre                      polyester/glass fibre
  - density                              1.81 g/dm<sup>3</sup>
  - glass content                      min. 50% ( in weight )
- mechanical characteristics
  - burst resistance                      50-100 bar dependig on polymer
  - traction resistance                      450-1200 Mpa
  - elongation to breakage                      2%
  - elastic module                      24000-45000 Mpa
  - cutting resistance                      70-130 MPa

A*	B*	C*
mm	mm	mm
60	40	40/31/27



N.B. the outer sheath of the glass resin pipe is co-extruded. This profile is inserted for high pressure injection purposes only.

Its only structural purpose is to give the end profile higher burst resistance and simplify the chemical and concrete injection processes.

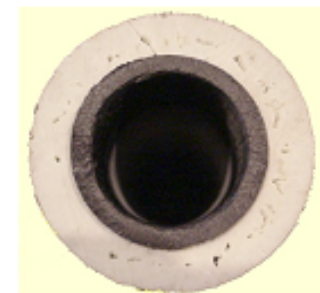

# ***Micropilotes de vitroresína***



# *Micropilotes de vitrosesína*

*P.E.R. Ground*



# ***Micropilotes de vitroresinas***

## **P.E.R. Ground**



# Micropilotes de vitroresinas

## SOIL NAILING SYSTEMS TESTED



**Traditional System [TV]**



**P.E.R. Ground® [PG]**

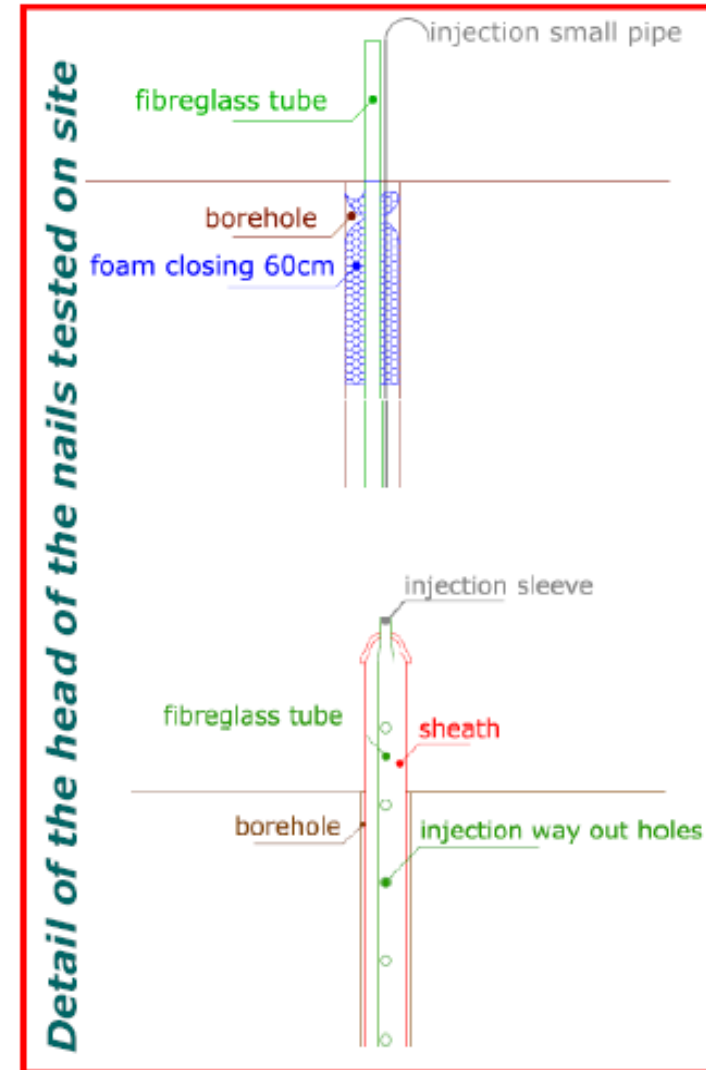

# Micropilotes de vitroresinas

## In Situ Test at Excavation Face

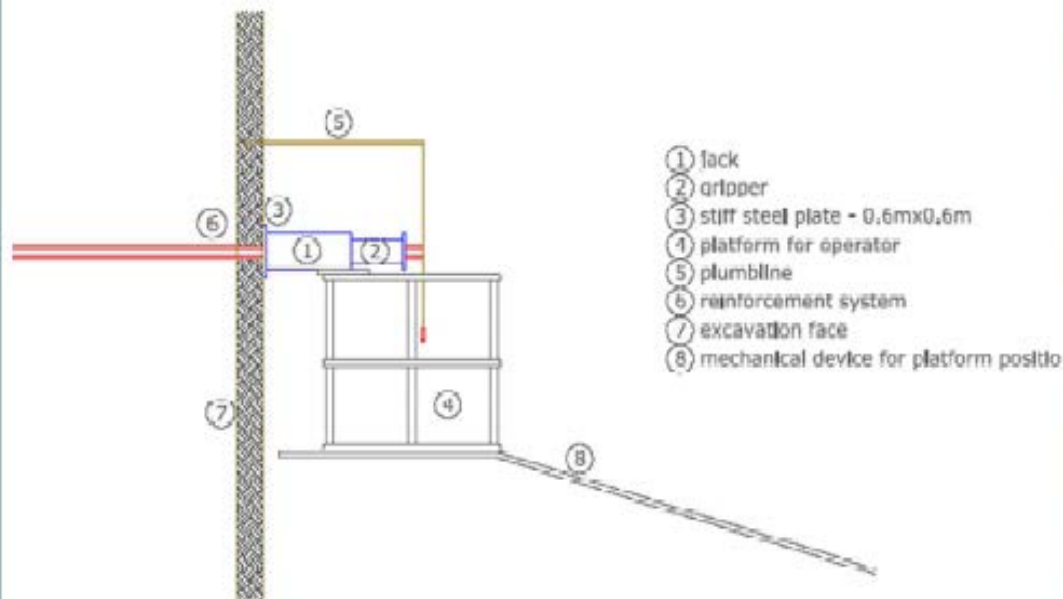

Figure 5. Pull out test set up and devices





# Micropilotes de vitroresinas

## Results

### 2 DAYS TESTS

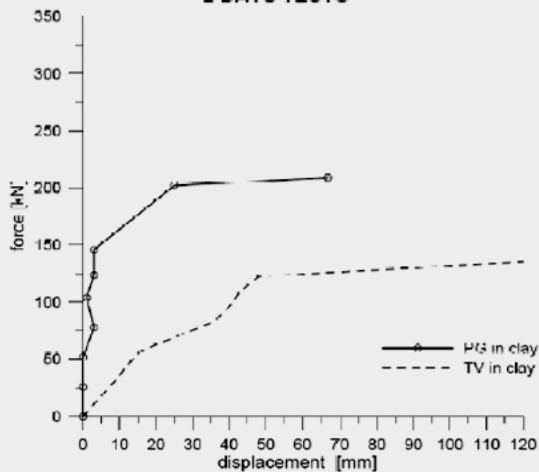

### 7 DAYS TESTS

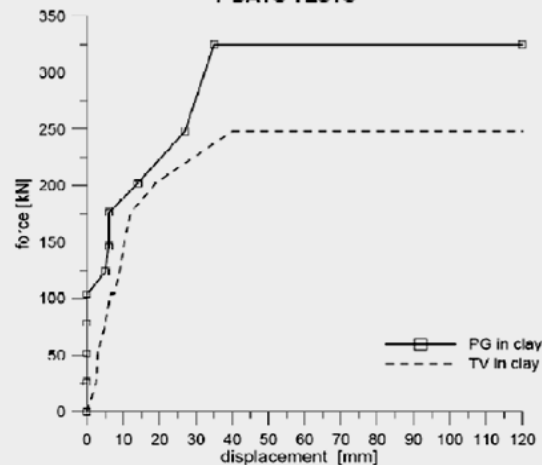

## Results

### 2 DAYS TESTS

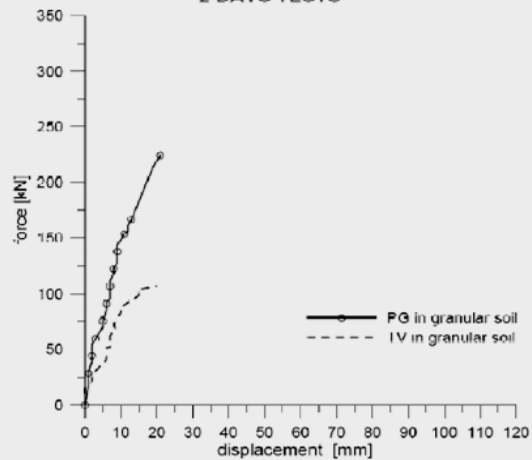

### 7 DAYS TESTS

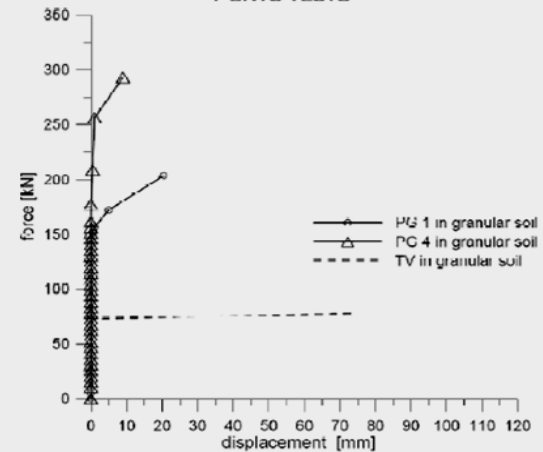

# *Micropilotes de vitroresinas*

*Pullout test results on improved (PG) and traditional (TV) soil nails*

<b>Nail Type</b>	<b>T [day]</b>	<b>L [m]</b>	<b>IV [l/m]</b>	<b>F<sub>MAX</sub> [kN/m]</b>	<b>S<sub>MAX</sub> [mm]</b>	<b>SR<sub>MAX</sub> [mm]</b>
<b>PG</b>	<b>2</b>	<b>5.93</b>	<b>18.9</b>	<b>37.94</b>	<b>21</b>	<b>3</b>
<b>PG</b>	<b>7</b>	<b>5.13</b>	<b>18.7</b>	<b>57.31</b>	<b>27</b>	<b>9</b>
<b>PG</b>	<b>28</b>	<b>5.44</b>	<b>15.9</b>	<b>63.60</b>	<b>32</b>	<b>4.5</b>
<b>TV</b>	<b>2</b>	<b>4.25</b>	<b>34.6</b>	<b>25.118</b>	<b>20</b>	<b>13</b>
<b>TV</b>	<b>7</b>	<b>4.33</b>	<b>29.6</b>	<b>18.01</b>	<b>80</b>	<b>75</b>
<b>TV</b>	<b>28</b>	<b>4.3</b>	<b>29.8</b>	<b>47.44</b>	<b>39</b>	<b>39</b>

**T:** test time after injection

**IV:** injected volume per meter of nail

**F<sub>MAX</sub>:** Maximum axial load per meter of nail

**S<sub>MAX</sub>:** Maximum recorded displacement

**SR<sub>MAX</sub>:** Maximum recorded residual displacement

# Contención con vitroresinas

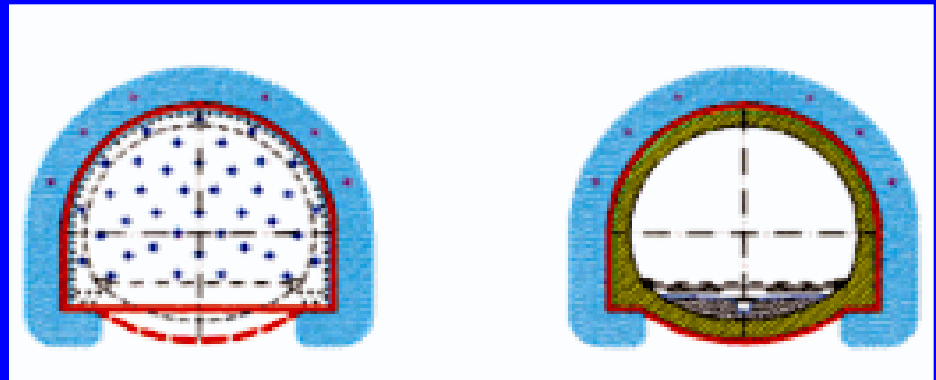
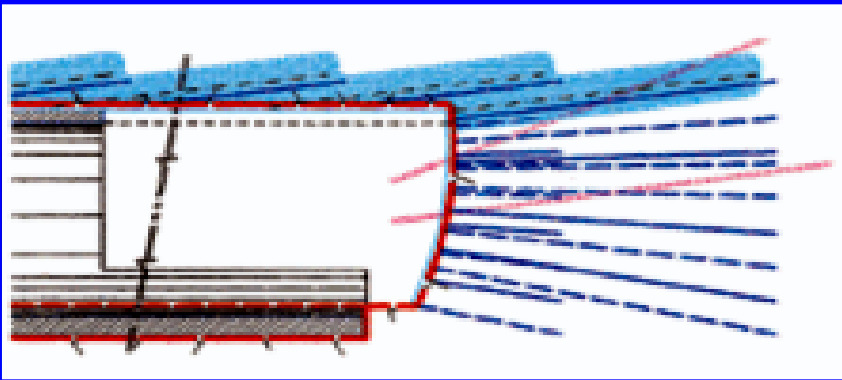

Peso specifico	ASTM D 792	1,9	g/cm <sup>3</sup>
Contenuto in vetro	-	70	%
Resistenza a trazione	ASTM D 3916	1000	MPa
Modulo elastico	ASTM D 3916	40	GPa
Allungamento a rottura	ASTM D 3916	> 3	%
Resistenza al taglio	-	200	MPa

# Contención con vitroresinas

PHASE 1: Perforation



PHASE 2: Positioning pipes



# *Contención con vitroresinas*

PHASE: 3 Injection



PHASE 4: Digging



# ***Frente consolidado con vitroresinas***



# ***Frente consolidado con vitroresinas***



# ***Frente consolidado con vitroresinas***





# ***Frente consolidado con vitroresinas***



# ***Frente consolidado con vitroresinas***



# ***Frente consolidado con vitroresinas***





*San Vitale tunnel - Caserta-Foggia railway line. Ground: scaly clay. Overburden: ~ 130 m. Face reinforced with fibre glass structural elements . [Lunardi Project]*



*Colle Pece Tunnel. Face reinforced with fibre glass structural elements.  
Ground: scaly clays. Overburden: ~ 25 m* [Lunardi Proyect]



*Macchia Piana Tunnel. Face reinforced with fibre glass structural elements.  
Ground: tuff, Overburden: ~ 3 m. [Lunardi Proyect]*



*View of the portal constructed using a shell of ground improved by means of jet-grouting and face reinforced with jet grouting elements. In Campinas (Brazil) [Lunardi Proyect]*

# LA ESTABILIDAD DEL FRENTE DE EXCAVACIÓN EN LOS TÚNELES SUPERFICIALES

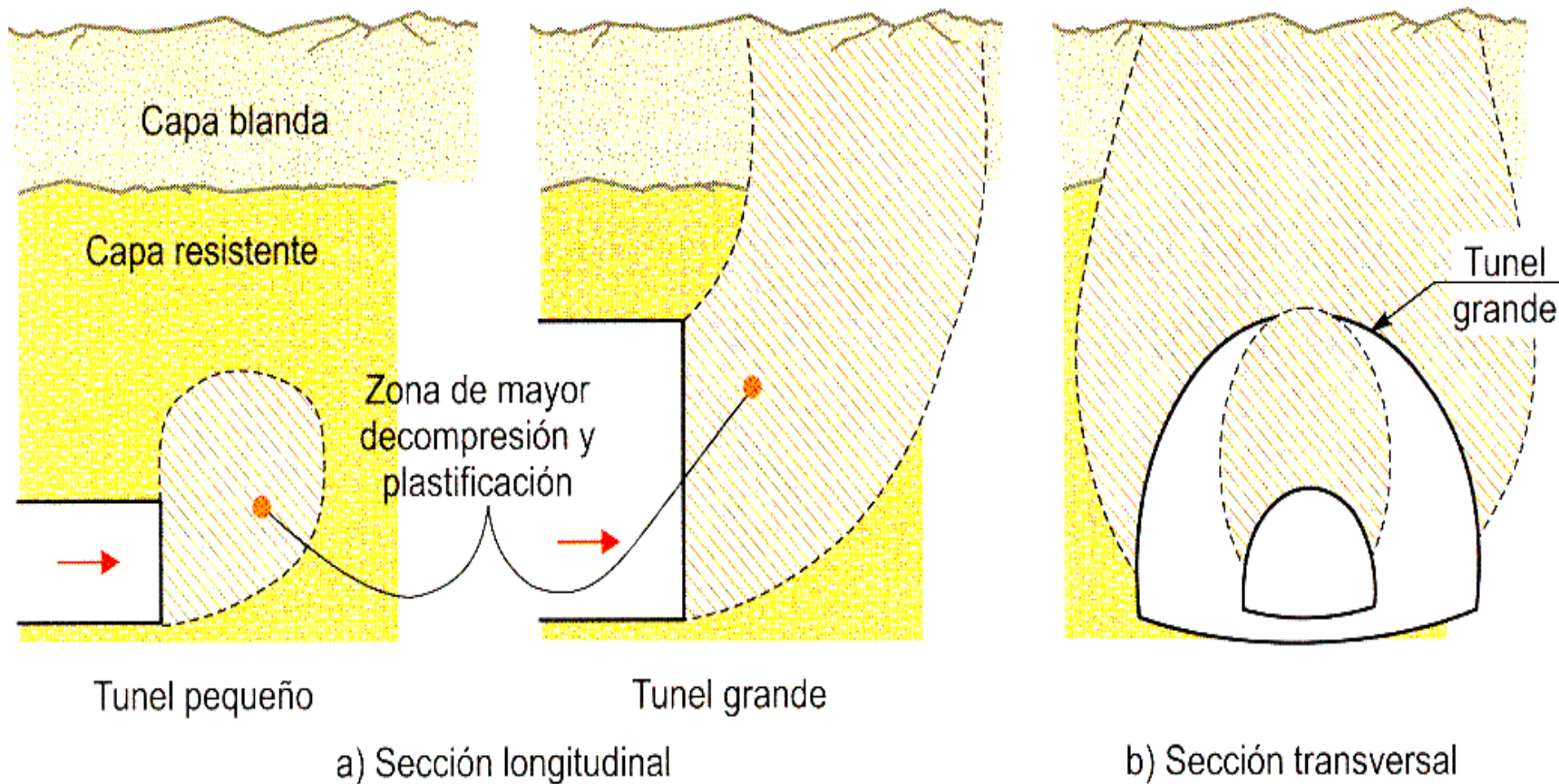



Factor de Estabilidad del Frente (N), Peck (1969):  $N = (P_o - P_e) / c$

Para  $N = 5$  el Frente se encuentra en equilibrio límite:  $FSf = 5 c / (P_o - P_e)$

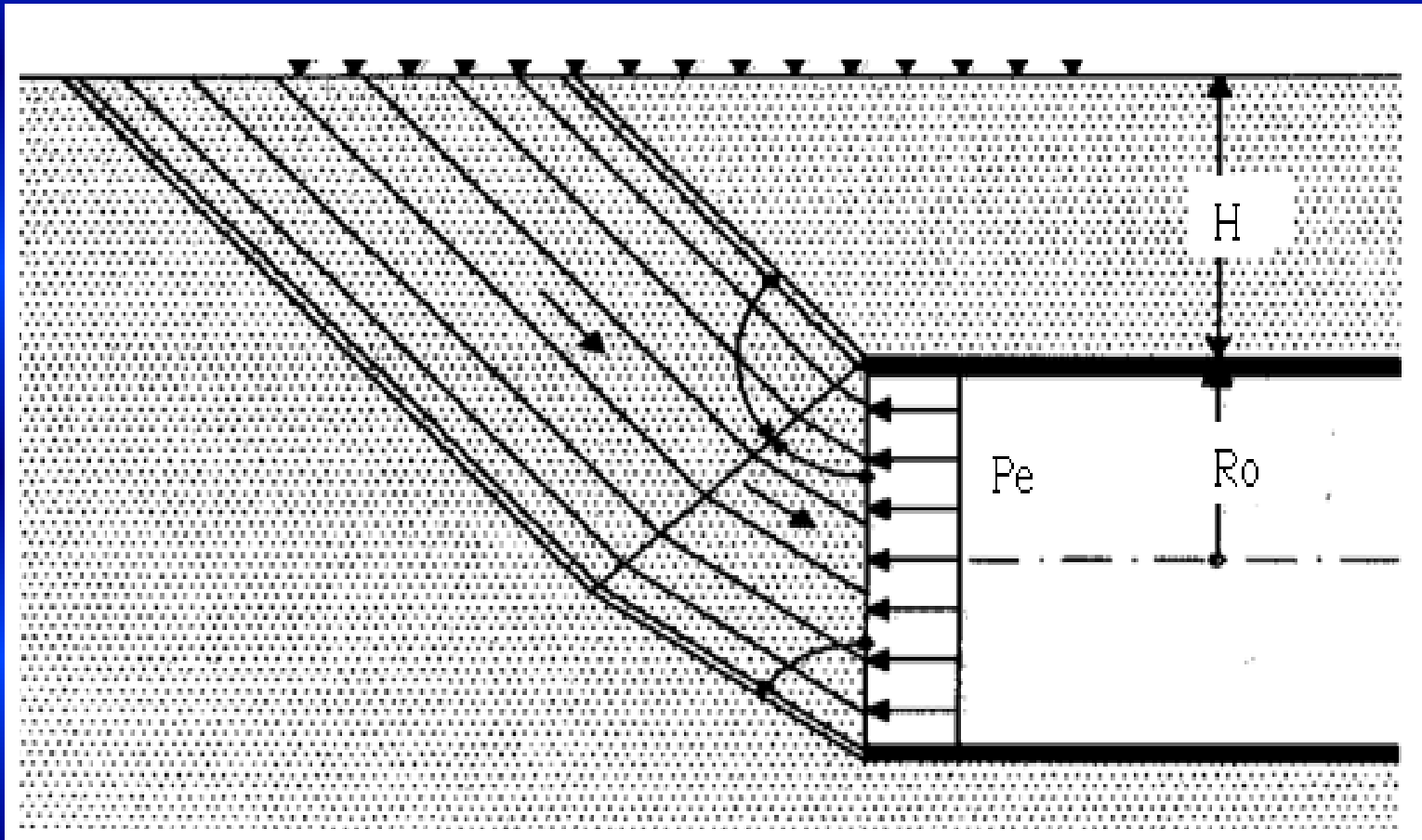

$$P_e = P_o - 5c/FSf = \gamma (H+R_o) - 5 c/ FSf$$

## ESTABILIZACIÓN DEL FRENTE DE UN TÚNEL DE 5 m DE RADIO

**Presión (t/m<sup>2</sup>) de estabilización sobre el frente para FSf = 1.25**

<i>c</i> (t/m <sup>2</sup> ):	0	2	4	6	8	10
<i>H</i> (m)						
10	30	22	14	6	0	0
15	40	32	24	16	8	0
20	50	42	34	26	18	10
25	60	52	44	36	28	20

**Cuantía de Vidrioresinas sobre el frente para FSf = 1.25**

<i>c</i> (t/m <sup>2</sup> ):	0	2	4	6	8	10
<i>H</i> (m)						
10	83	61	39	17	0	0
15	111	89	66	44	22	0
20	138	116	94	72	50	28
25	166	144	122	100	77	55

# POSIBLES MODELOS DE ESTABILIDAD DEL FRENTE DE EXCAVACIÓN

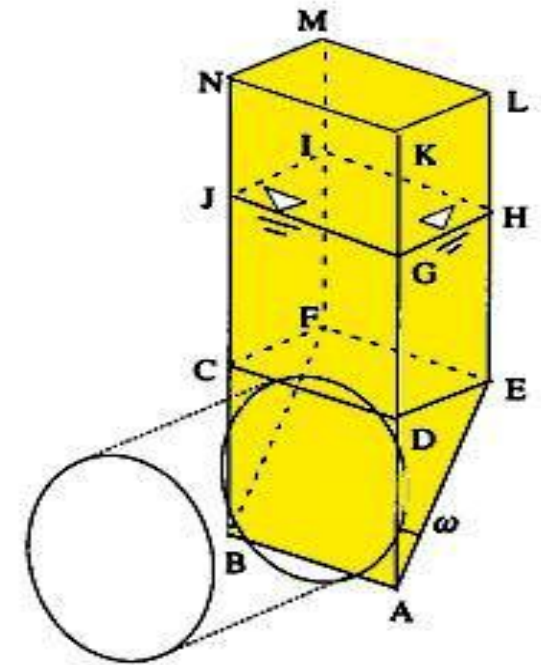
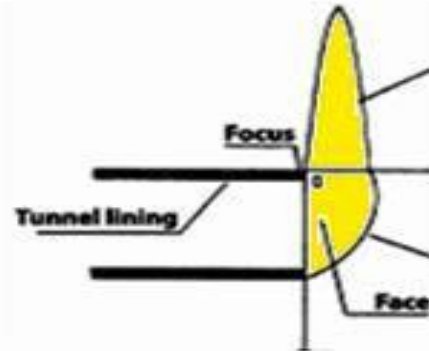
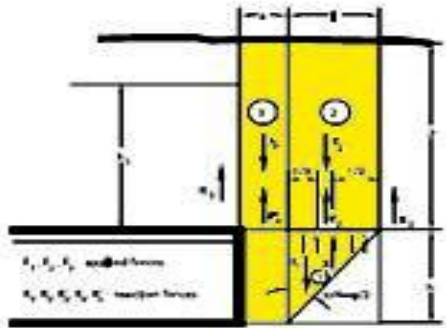
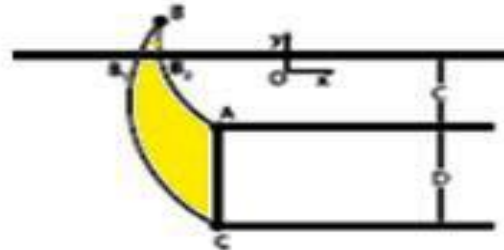
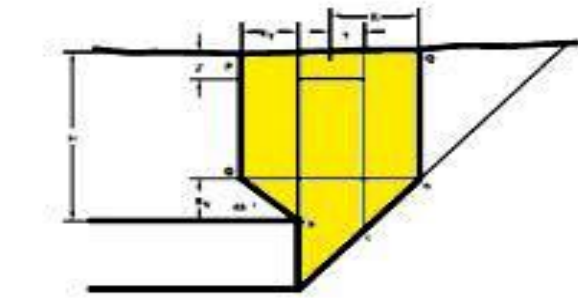

## Ejemplo de Dimensionado de la Estabilización del Frente de Excavación

Presión (t/m <sup>2</sup> ) de estabilización sobre el frente para FSf = 1.25						
c (t/m <sup>2</sup> ):	0	2	4	6	8	10
H (m)						
10	30	22	14	6	0	0
15	40	32	24	16	8	0
20	50	42	34	26	18	10
25	60	52	44	36	28	20

Cuantía de Vidrioresinas sobre el frente para FSf = 1.25						
c (t/m <sup>2</sup> ):	0	2	4	6	8	10
H (m)						
10	83	61	39	17	0	0
15	111	89	66	44	22	0
20	138	116	94	72	50	28
25	166	144	122	100	77	55

Presión de estabilización sobre el frente Vs. cobertura y tipo de Terreno    Cuantías de Vidrio-resinas sobre el Frente Vs. Cobertura y tipo de Terreno

# MODELOS NUMÉRICOS DE ESTABILIDAD DEL FRENTE DE EXCAVACIÓN

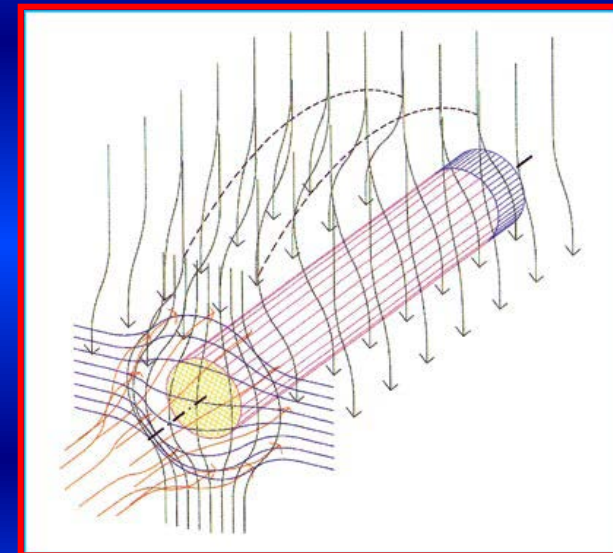
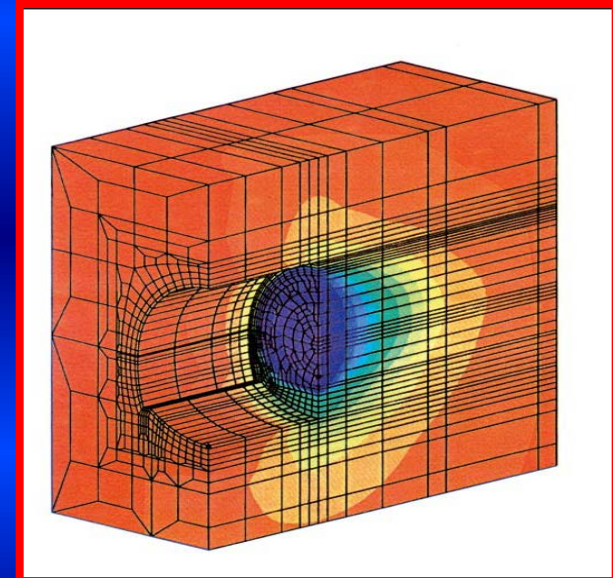
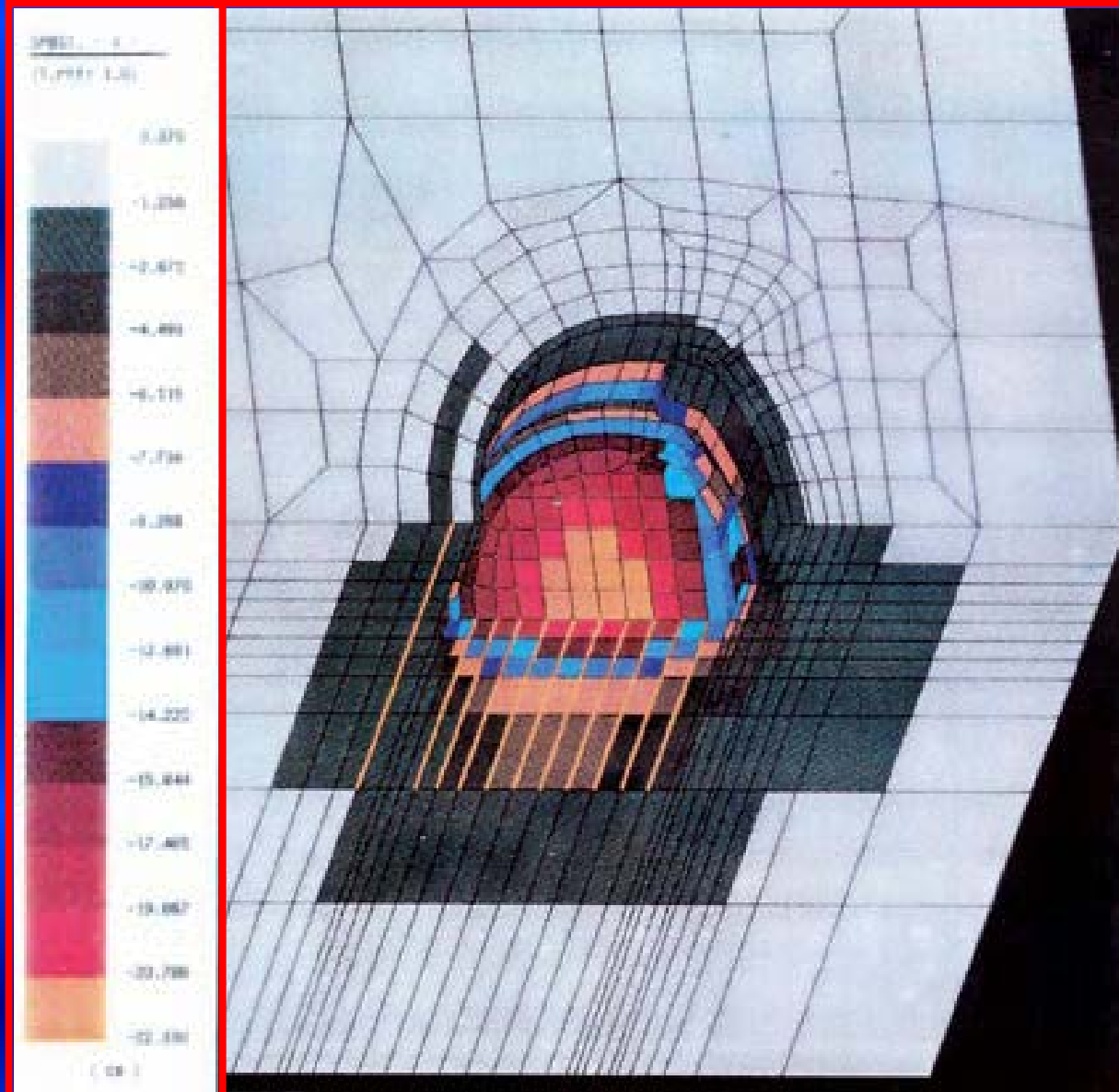

## Ancona - Bari railway line - "Vasto" tunnel Extrusion-convergence diagrams related to tunnel advance

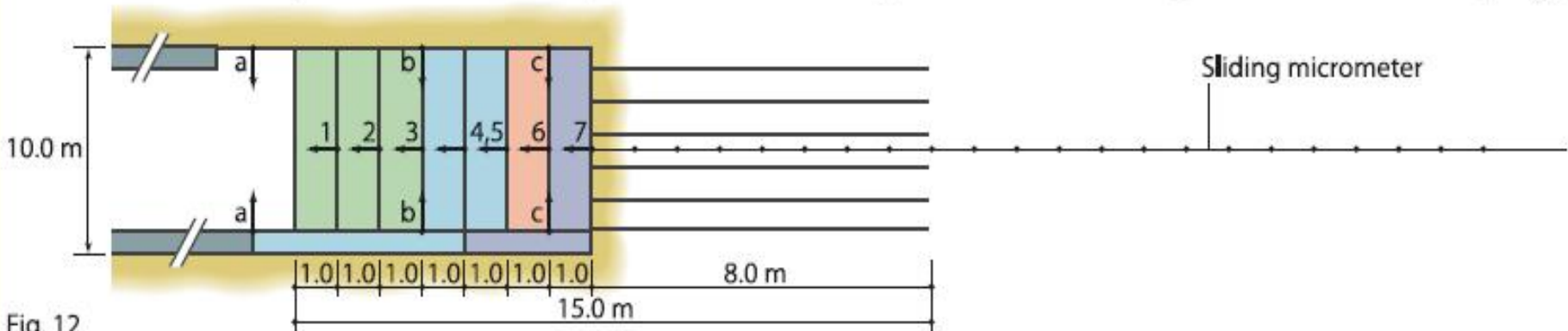
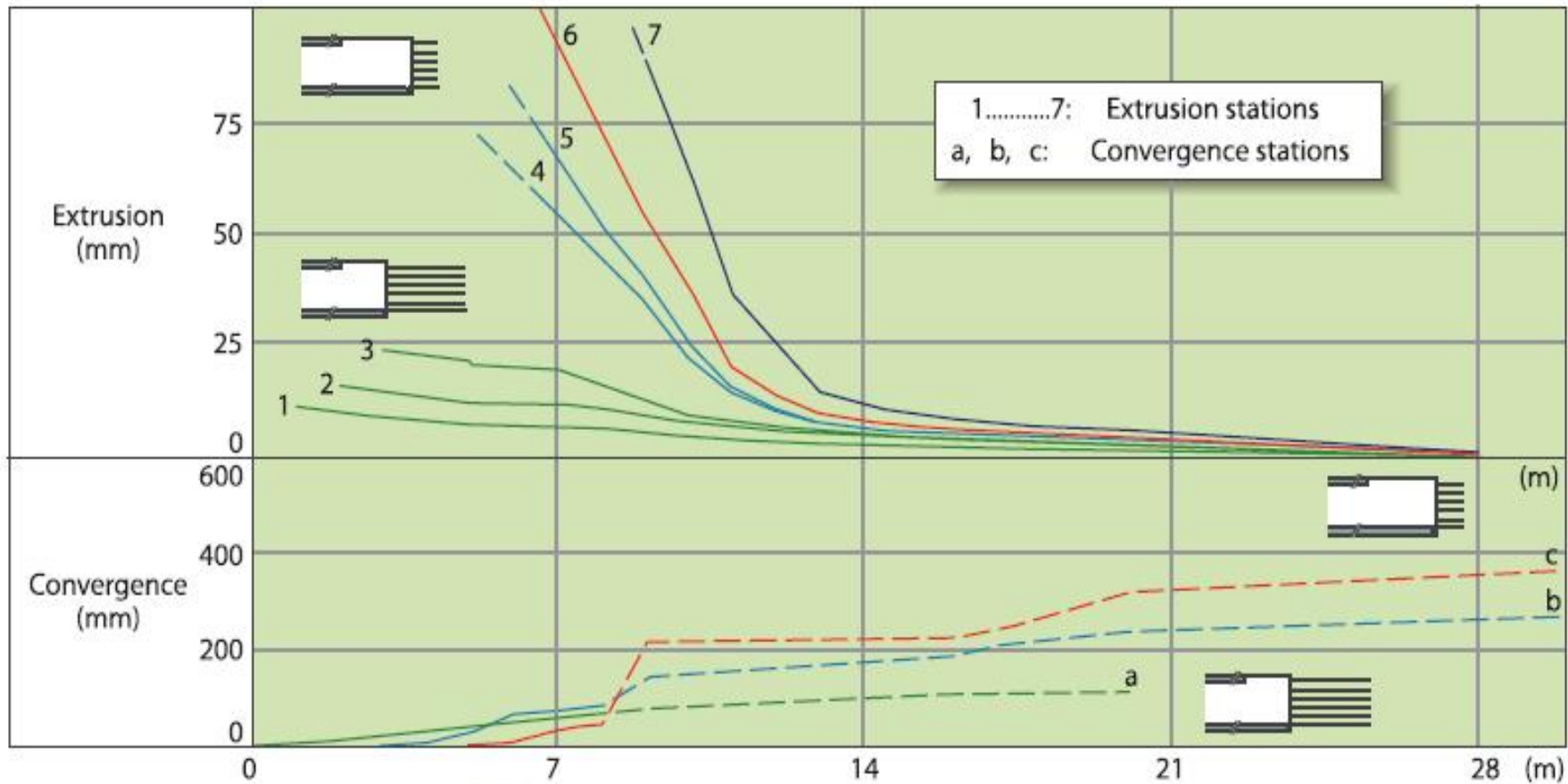

# Cuantía aprox. y prel. de VTR Vs Extrusión $\delta_0$ o Cobertura y Cohesión\*

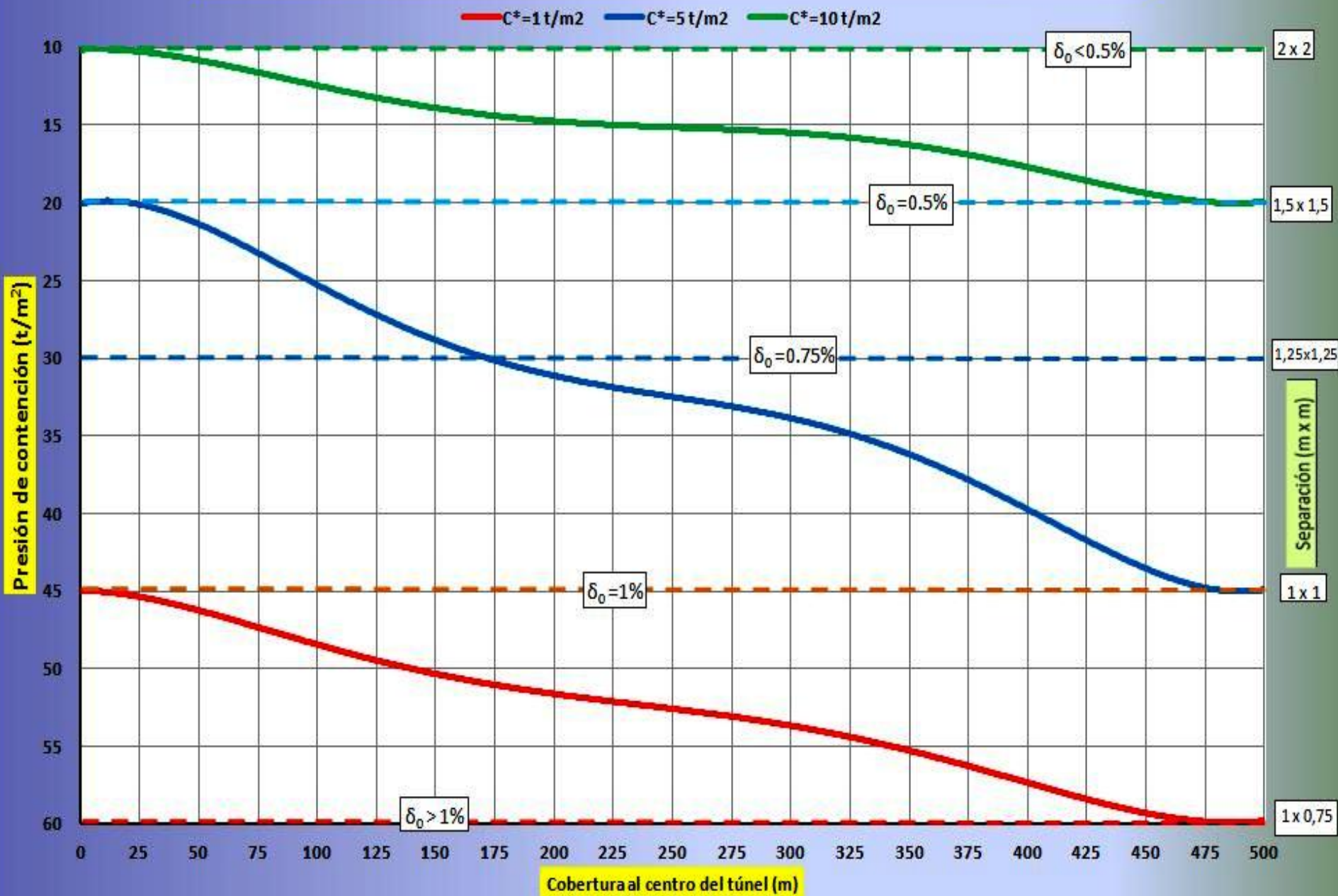

## REFUERZO DEL FRENTE DE EXCAVACIÓN CON ELEMENTOS DE VIDRIORESINAS

*porque?*

PARA AVANZAR A SECCIÓN COMPLETA EN TÚNELES CON TERRENOS DEBILES

- *También para excavar en condiciones de mayor seguridad*
- *También para excavar con equipos más potentes*
- *También para excavar con mayor velocidad*
- *También para excavar en mayor economía*



*Gracias*