

4300

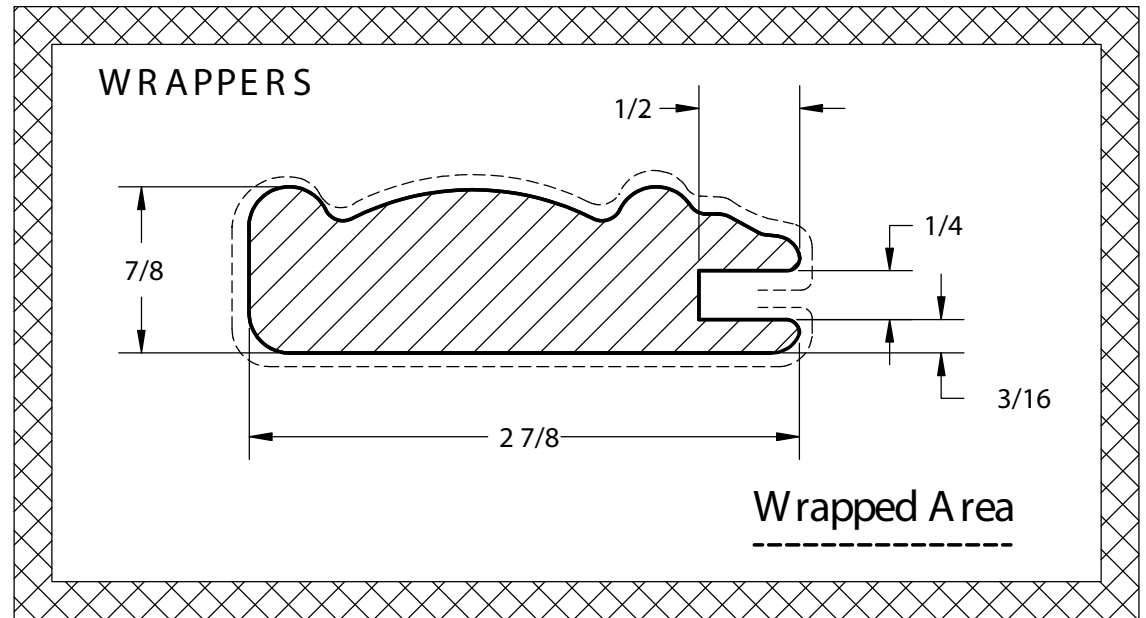

MOULDERS

Moulding must be machined off the bottom, to eliminate warpage.

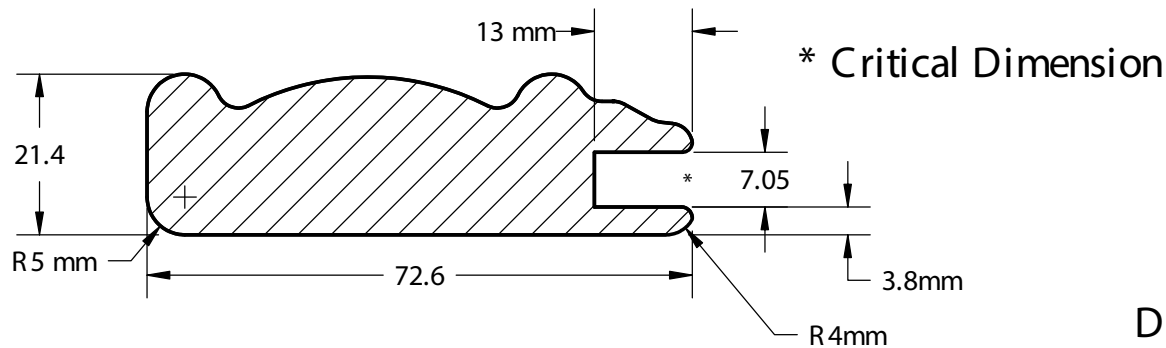

DOOR MOULDING

CUT SIZE	1" x 75.4mm	REV.	DESCRIPTION	DATE		
LAMINATE SIZE :	7 3/8"	1 KB	Change to 1"	2/06/04	PROFILE NO :	4300
COMMENTS : Machine bottom of moulding, start with 2mm and adjust until the warp is eliminated.		2 JD	Increased the groove to 6.45mm finished	Oct 28/04		
		3 CB	Changed raw sizes to match 5 mil laminates	Nov 09/05		
					DRAWN BY: JD	DATE: June 11/03
TOLERANCE +/- 0.2mm UNLESS SPECIFIED					SCALE: 1 TO 1	