

Gas Leakage Detection with GSM Alert

Athira K.R

Department of Electronics and Communication
Sahrdaya College of Engineering and Technology
Thrissur, India
athira.raghunadh@gmail.com

Binet Rose Devassy

Department of Electronics and Communication
Sahrdaya College of Engineering and Technology
Thrissur, India
binetrose@sahrdaya.ac.in

Abstract— Combustible gases are a very common reason for blasts and fire accidents, causing large damage to life and property. So here an automated gas leakage detection and alerting system is proposed to alert users wherever they are about the leakage of combustible gas using SMS through GSM modem. For this purpose, I am using a PIC microcontroller along with MQ7 gas sensor, LCD display, LED board, GSM modem and a buzzer. The system is powered by a 12V power supply. The power supply system consists of a stepdown transformer of 230V/12V used to step down the voltage into 12V AC. A center tapped rectifier is used to convert it to DC. To remove the ripples a capacitive filter is used. A 7805-voltage regulator is used to regulate the voltage into 5V. The system constantly scans the gas sensor to detect leakages. As soon as gas is detected at the sensor, it produces an equivalent voltage and signals the microcontroller. On reading the signal microcontroller checks the amount of gas detected, if the value is above a certain level it goes into alert mode. System now shows the amount of gas detected on the LCD display. Different levels of gas leakage can be indicated using different colors of LED. The system also sounds a buzzer if there is high level gas leakage. This system is also useful when user is not at home because it sends an SMS to the user's mobile phone to inform about the situation.

Keywords—Gas Leakage Detection, MQ7 Gas sensor, GSM

I. INTRODUCTION

Toxic and inflammable gases are widely used in industry, heating systems, home appliances and vehicles. This includes combustible gases like propane, ethane, butane, methane, ethylene etc. Liquefied Petroleum Gas (LPG), also referred to as propane or butane are normally stored in pressurized cylinders in liquid form and vaporize at normal temperatures. A leakage can ignite and cause explosion. Therefore, the leakage detection of gases has gained more interest in recent years especially in fields of safety, industry, environment, and emission control.

A conventional gas leakage system uses on-site alarms as a warning to indicate the leakage. The drawback of the conventional leakage system is that it becomes ineffective in the absence of first response team on-site. This may delay the preventive actions causing damage to life and environment. Therefore, a gas leakage detection system that initiates a SMS as in [1] will be more effective in the absence of people on-site. The sensor used in this Project that is MQ7 will have both admirable sensitivity and rapid response time. This sensor can also be used to sense other gases also. So, this system will be useful in several areas.

The current systems available are costly and difficult to implement. So, an embedded system is designed using PIC 16F877A Microcontroller as in [2], [3] for detection of hazardous gas leakage. The system is affordable and can be easily implement in the chemical industries and in residential area which is surrounded by the chemical industries or plants, to avoid endangering of human lives.

The main objective of the work is designing microcontroller based toxic gas detecting and alerting system. The hazardous gases like LPG and propane were sensed and displayed each second in the LCD display. If these gases exceed the normal level, then an alarm is generated immediately, and a SMS is sent to the authorized person through the GSM. The advantage of this automated detection and alerting system over the manual method is that it offers quick response time and accurate detection of an emergency and in turn leading faster diffusion of the critical situation.

The study is organized as follows. Section II discuss about the Proposed Method. Results and Discussions are explained in Section III. Finally, Conclusion and Future Scope are discussed in Section IV.

II. PROPOSED METHOD

The proposed system is mainly intended to be implemented in homes where high cost and complex systems are rarely used. The system constantly scans the gas sensor to detect gas leakages. As soon as gas is detected at the sensor, it produces an equivalent voltage and signals the microcontroller. The microcontroller on reading the signal checks the amount of gas detected, on detecting gas above certain level it then goes into alert mode. The system now shows the amount of gas detected on the LCD display.

The amount of gas detected can be displayed using different colors of LED. Red LED is used to indicate there is large amount of gas leakage in the system. Orange LED is used to indicate there is a medium level gas leakage in the system. Yellow LED is used to indicate there is low level gas leakage in the system. Green led is used to indicate safe level. The system also sounds a buzzer if there is medium or high level of gas leakage in the system to alert the user about that. The system also uses the GSM modem to send an SMS message to the user/authority to inform about the situation so required action can be taken for it. This is useful when user is not at home.

PCB design of power supply is given in the following fig.2. The system is powered by a 12V power supply. The power supply system consists of a stepdown transformer of 230V/12V used to step down the voltage into 12V AC. A center tapped rectifier is used to convert it to DC. To remove the ripples a capacitive filter is used. A 7805-voltage regulator is used to regulate the voltage into 5V.

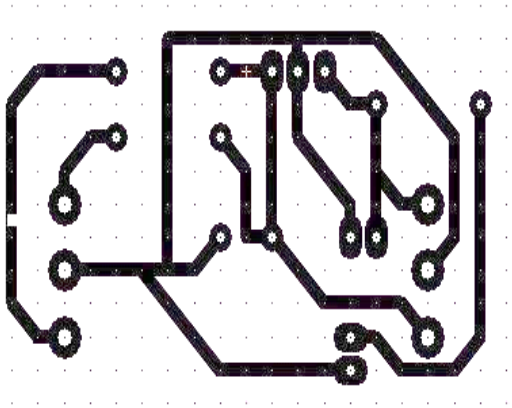

Fig. 2. PCB of 5V Power supply

PCB design of entire circuit is given in the following fig.3 with MQ7 sensor, LCD, GSM, four LEDs (Red, Orange, Yellow Green) and the microcontroller which is PIC16F877A.

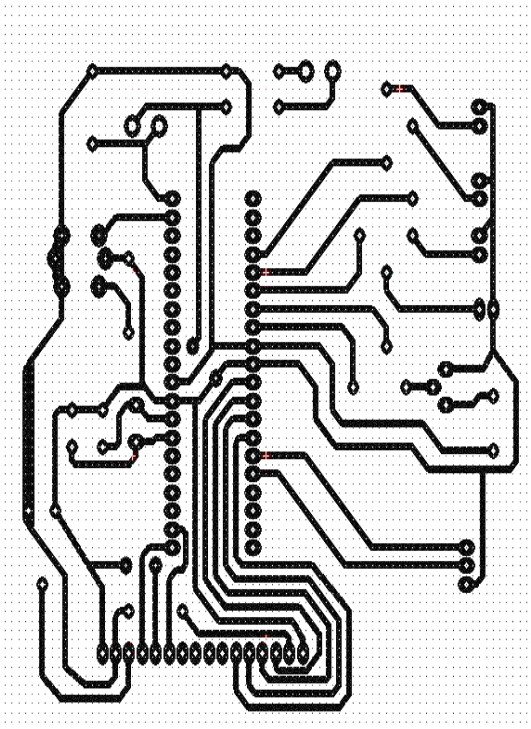

Fig. 3. Proteus design of System

Data flow in the system is shown in Fig. 1 as follows. The gas sensor used here is MQ7. After the power is on, microcontroller reads input from the sensor. We can set a threshold value and we can give alerts according to the values got from the sensor by comparing with the threshold value.

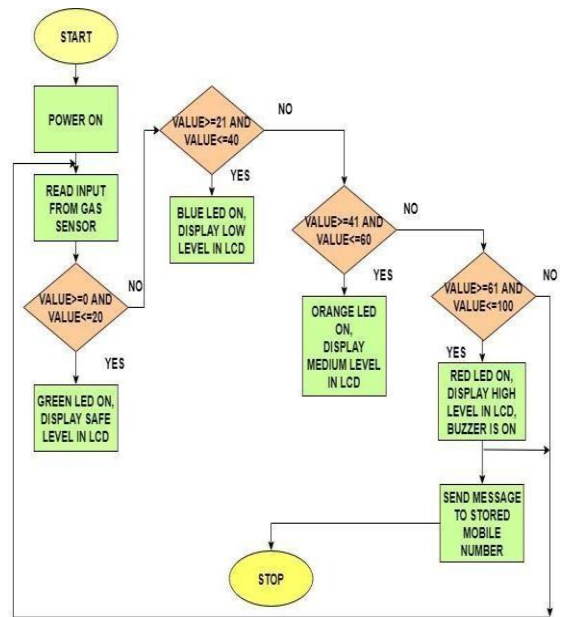

Fig. 1. Flow Chart

III. RESULTS AND DISCUSSION

The micro-controller simulation in Proteus works by applying either a hex file or a debug file to the microcontroller part on the schematic. The SMS is sent using a virtual terminal in Proteus. The following figure represents the simulation of high level gas leakage. Red LED is on and value is displayed in the LCD. The SMS is sent, it can be seen in Virtual Terminal.

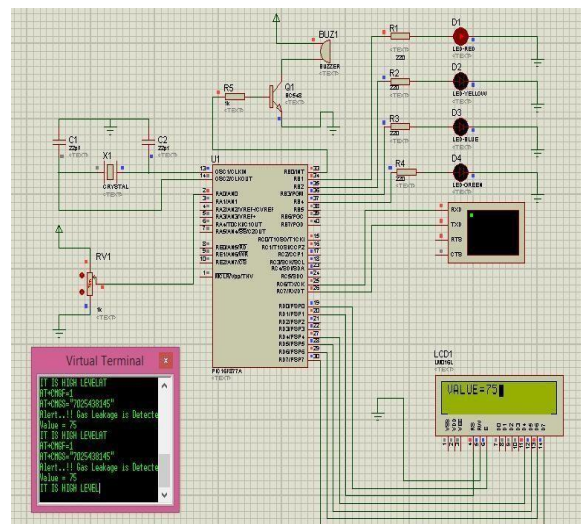

Fig. 2. Hardware

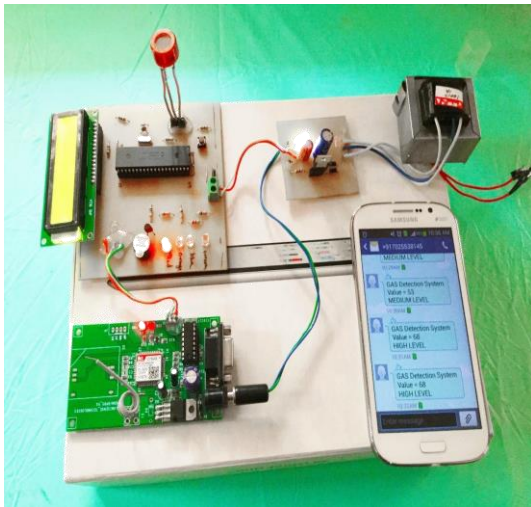

Fig. 4. Hardware

IV. CONCLUSION AND FUTURE SCOPE

The proposed gas leakage detector is promising in the field of safety. The Micro-controller detects the leakage and alert the user in different ways if gas leakage is detected. LCD display, LEDs and Buzzer are useful when the user is present at the place. The system also useful when user is not present at the place because it will send a SMS to user's mobile through a GSM module. A prototype of the gas leakage detector has been developed and successfully tested with LPG. The detector can send the SMS to the mobile number stored in the system in less than a minute.

The cost involved in developing the system is significantly low and is much less than the cost of gas detectors commercially available in the market. Applications of proposed system includes Protection from any gas leakage in cars, Safety from gas leakage in heating gas red appliances like boilers and domestic water heaters, for large industries which produces gas, Safety from gas leakage in cooking gas fired appliances like ovens, stoves, etc. The proposed gas leakage detection system can be extended to send calls/SMS to multiple people and can be directly linked to the relay station as well. By make use of various emerging technologies and methods, we can enhance the accuracy of this project as in [4], [5], [6], [7], [8], [9], [10], [11], [12].

AKNOWLEDGMENT

I want to express my thanks to my guide Ms. Binet Rose Devassy Asst. prof, Dept. of Electronics and Communication Engineering for the valuable advice and guidance towards this work. I also thank my project coordinator Santhosh Kumar M S, Asst. prof. of ECE department for the support and guidance.

REFERENCES

- [1] Mr. Arijit Banik, Mr. Bodhayan Aich, Mr. Suman Ghosh, "Microcontroller Based Low Cost Gas Leakage Detector with SMS Alert", IEEE conference, 2018
- [2] Shruthi Unnikrishnan, Mohammed Razil, Joshua Benny, Shelvin Varghese and C.V. Hari, "LPG Monitoring and Leakage Detection System", IEEE WiSPNETconference 2017
- [3] Ajay Kumar, Mukesh Kumar, Balwinder Singh "Designing and Implementaion of Smart LPG Trolley with Home Safety", 2nd International Conference on Next Generation Computing Technologies (NGCT-2016)
- [4] Mr. Sahil Adsul, Mr. Ashok Kumar Sharma, Mr. R. G. Mevekari, "Development of Leakage Detection System", International Conference on Automatic Control and Dynamic Optimization Techniques (ICACDOT),2016
- [5] Anindya Nag, Asif Iqbal Zia, Member, IEEE, Xie Li, Subhas Chandra Mukhopadhyay, Fellow, IEEE, and Jürgen Kosel, "Novel Sensing Approach for LPG Leakage Detection: Part I—Operating Mechanism and Preliminary Results", IEEE SENSORS JOURNAL, VOL. 16, NO. 4, FEBRUARY 15, 2016
- [6] Anindya Nag, Asif Iqbal Zia, Member, IEEE, Xie Li, Subhas Chandra Mukhopadhyay, Fellow, IEEE, and Jürgen Kosel, "Novel Sensing Approach for LPG Leakage Detection—Part II: Effects of Particle Size, Composition, and Coating Layer Thickness", IEEE SENSORS JOURNAL, VOL. 16, NO. 4, FEBRUARY 15, 2016
- [7] Lamine Salhi, Thomas Silverston, Taku Yamazaki, and Takumi Miyoshi, "Early Detection System for Gas Leakage and Fire in Smart Home Using Machine Learning", IEEE International Conference on Consumer Electronics (ICCE),2019
- [8] Shawkat Jahan, Shibly Talukdar, Md. Mahafuzul Islam, Md. Minhajul Azmir, Ahmed Mortuza Saleque, "Development of Smart Cooking Stove: Harvesting Energy from the Heat, Gas Leakage Detection and IoT Based Notification System", International Conference on Robotics,Electrical and Signal Processing Techniques (ICREST),2019
- [9] Meer Shadman Saeed, Nusrat Alim, "Design and Implementation of a Dual Mode Autonomous Gas Leakage Detecting Robot", International Conference on Robotics,Electrical and Signal Processing Techniques (ICREST), 2019
- [10] Binglu Liu, Haocheng Ma, Xiaoping Zheng, Lihui Peng, Anshan Xiao, "Monitoring and Detection of Combustible Gas Leakage by Using Infrared Imaging", IEEE conference 2018
- [11] Tania Mukherjee and Ambarish Paul, "Dielectric Breakdown-Based Gas Leakage Detector Using Poly-Si Microtips", IEEE TRANSACTIONS ON ELECTRON DEVICES, VOL. 65, NO. 11, NOVEMBER 2018
- [12] Jianyun Ni, Zihao Li, Shuzi Xie, Chao Jia "Toxic gas leak monitoring alarm system based on wireless sensor network", IEEE conference 2018