

Multiple Applications



Water Management Solutions, Inc.

Going the extra mile starts here!™



Wellpoint Accessories

Water Management is proud to be a MWI Pump Partner, where we have access to some of the best products on the market. With our partnership, we can offer multiple accessories for your wellpoint project that will increase productivity and help simplify the process. Contact us today and see if any of the accessories below work for you!

Economical

Widely Employed

Multiple Accessories



Wellpoint

These PVC Wellpoints with conical end caps are used to draw water and air from beneath the ground to temporarily lower the water table and allow for construction. We also carry self-jetting wellpoints.



Header Couplings

These flexible rubber sleeves have stainless steel clamps to quickly join header pipes.



Swing Joints

Our swing joints are equipped with clear plastic elbows to monitor the flow of water and control values to maintain vacuum levels. Both ends connect quickly and easily.



Bauer-Type Fittings

MWI provides a variety of Bauer-type quick connect/disconnect coupling and adapter fittings including; hose ends, screw ends, pipe bends, adapters, flanged ends, rubber sealings, and closure rings.



Header Pipe

Headers collect the water from the wellpoints and deliver it to the pump. MWI PVC Schedule 40 header pipe is available in an 8 inch diameter and 20 foot lengths.



Hoses and Fittings

MWI has a complete line to fit any application. We provide a variety of hoses ranging from suction hose to high pressure discharge hose. All are available with an assortment of couplings and fixtures.



Header Pipe Fittings

These header pipe fittings come in a number of configurations including; 450 bend, 900 bend, tee and blank end. All fit with extra strength rubber sleeves and stainless steel clamps.

Contact Us!

434-664-8845

mark@watermngt.com

wendy@watermngt.com

www.watermngt.com

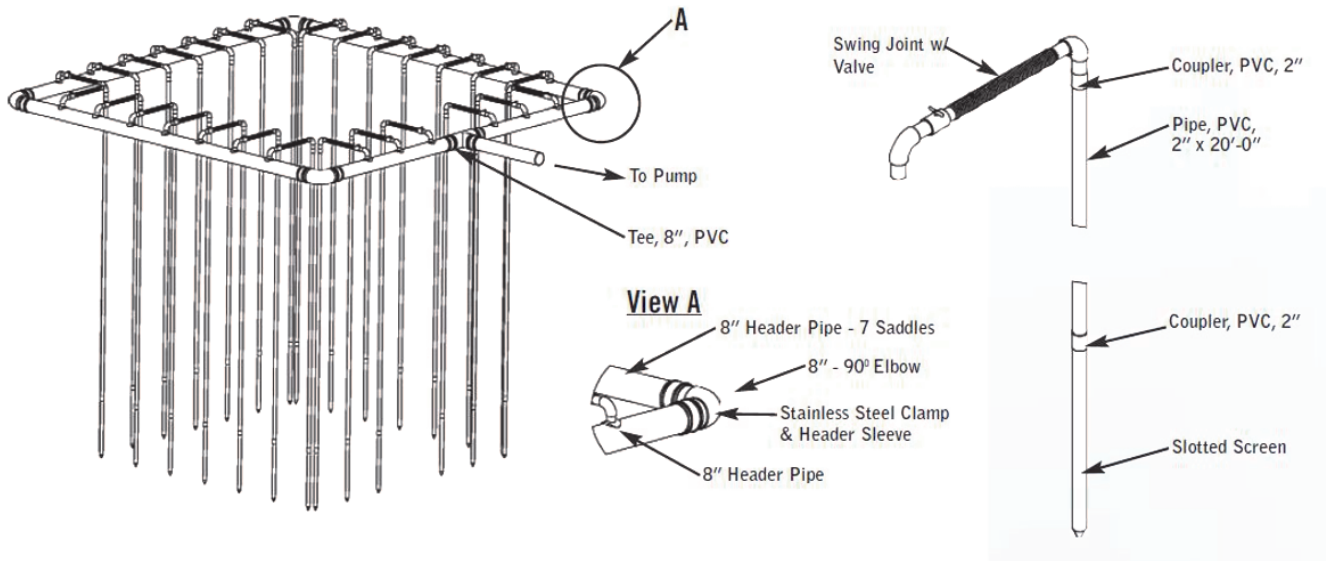

The wellpoint system is used to lower the water table to allow construction of buildings and civil works. All pipes shown bring water from the ground to the suction port in the pump. Discharge from the pump is then either directed to a canal or catch basin depending on site conditions.



Jet Pumps

MWI's high pressure jet pumps make short work of gravel washing, drilling, pipeline testing, equipment cleaning, piling and wellpoint jetting, as well as any other high pressure applications.

These heavy-duty pumps can handle your toughest jetting job with flows of 600 gpm and pressures to 200 psi. The units are complete and ready to operate in either skid or portable configurations with an open industrial power unit, integral fuel tank, lifting bail, control panel and hand or compressor-driven primer.



Water Management Solutions, Inc.

434-664-8845 · www.watmngt.com