



Installation, Operation & Maintenance Manual

*MEDIUM DUTY
FOUR POST LIFT*

18,000 lbs Capacity

*Model 44018-AR
Model 44018X-AR*

200 Cabel Street, P.O. Box 3944 Louisville, Kentucky 40201-3944
Email: sales@challengerylifts.com Web site: www.challengerylifts.com
Office 800-648-5438 / 502-625-0700 Fax 502-587-1933

**IMPORTANT: READ THIS MANUAL COMPLETELY
BEFORE INSTALLING or OPERATING LIFT**

IMPORTANT INFORMATION

1. The floor where the lift is to be installed must be a minimum of 4" thickness of concrete. Concrete must be reinforced with steel rebar with a minimum compressive strength of 3,000 psi. Failure by the purchaser to provide the recommended mounting surfaces could result in personal injury, property damage and/or unsatisfactory lift performance.
2. Read the installation manual before installing the lift.
3. This lift is a four post lift which requires a minimum (44018AR) 15' x 30'-0" / (44018XAR.) 15' x 33'-0" bay area.
4. Read anchoring tips information before drilling and installing the anchor bolts.
5. Do not raise a vehicle with the lift until the lift has been correctly installed and adjusted as described in this manual.
6. Maximum floor variation between any two posts is 1/2 inches.

CAUTIONS AND WARNINGS

MOTORS AND ELECTRIC CONTROLS ARE NOT SEALED
against weather or moisture. Damage or Electrical shock may occur if installed unprotected outdoors.

FACTORY MUST BE NOTIFIED WITHIN 30 DAYS OF DELIVERY
If there are any parts missing from shipment.

ALL BOLTS PLACED IN COLUMNS MUST BE PLACED
FROM OUTSIDE FACING INWARD. UNLESS NOTED IN THE
INSTALLATION INSTRUCTIONS

TOOLS REQUIRED

Concrete rotary hammer drill with 3/4" carbide bit
Open End Wrenches: 7/16", 1/2", 3/4", 1 1/8"
Ratchet Driver
Sockets: 1/2", 3/4" X 1/2" deep
12" Crescent Wrench
Hammer
Needle Nose Pliers
Retainer Ring Pliers
Electrical Pliers
Level
Fish Tape
25' Tape Measure
Chalk Line
Small Drift Punch
Step Ladder
3 gallons of hydraulic medium oil SAE-10 or equivalent
4 x 4 Wood Blocks

ANCHORING TIPS

1. Anchor must be at least 7 1/2" from the edge of the slab or any seam.
2. Use a concrete hammer drill with a 3/4" carbide bit.
3. Do not use a worn bit.
4. Drill in a perpendicular line with the hole.
5. Do not apply excessive pressure to the drill. Let the drill do the work.
6. Lift the drill up and down occasionally to remove residue and to reduce binding.
7. Drill the hole depth equal to the length of the anchor, or completely through the slab.
8. Blow all dust / residue from the hole before driving anchor into hole.

Place a flat washer over threaded end of anchor. Spin nut 1/2" down past end of anchor. Carefully tap anchor into the concrete until nut and flat washer are against base plate.

Do not use an impact wrench to tighten.

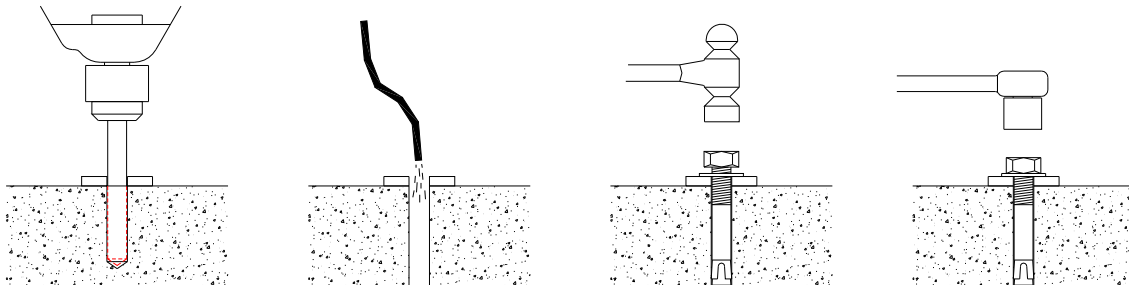

INSTALLATION INSTRUCTIONS

Area required for four post alignment lift is a minimum of (44018AR) 15' x 30' or (44018XAR) 15' x 33' area.

Using the chalk line layout a rectangle (44018AR) 11'- 9 1/2" x 18'-1" or (44018XAR) 11'-9 1/2" x 21'-1" at least 4'-9 3/4" from the ramp location and 1'-1 1/4" from either side of the lift (see Layout & Installation Specification sheet). This should give the lift 4" clearance in front of the ramps and 1'-1 1/4" from the side of any column.

Unpacking lift, inspect lift for any damages due to transportation and check shipping list for missing parts.

Locate both Main side Columns (see **Fig. #2**). Position columns as shown in the Installation Specification sheet for recommended installation. Optional – Main side Columns can be mounted on opposite side of lift depending on customer preference Hold the (44018AR) 17'-0" or (44018XAR) 20'-0" dimension of the columns center to center.

1. After measuring, (see **Fig. #5A**) drill holes using a 3/4" diameter carbide drill bit. Keep in mind the anchoring tips mentioned previously in the manual. After drilling all 8 hole on the Main side Columns, anchor them down with 3/4-10UNC 5 1/2 anchor bolts (8 pcs.-91578A501). Make sure columns are level and plumb. Use 1/2-13UNC x 2 all threaded HHCS (8 pcs.-92865A720) with 1/2-13UNC reg. hex nuts (8 pcs.-90473A223) at the base plate to level columns. Make sure all bolts are properly set and meet 75 ft. lbs of torque. DO NOT USE AN IMPACT.
2. Locate Top Rail assembly as shown in **Fig. #1**. mount Top Rail assembly on top of Main side Columns (see **Fig. #5A & #5C**). Secure Top Rail to Main side Columns using 1/2-13UNC x 2 HHCS (4 pcs.-91247A720), 1/2 flat washers top and bottom (4 pcs.-90126A033), 1/2 lock washers (4 pcs.-91102A033) & 1/2-13UNC hex nut (4 pcs.-90473A223).
3. Locate LH & RH Cross Rails see **Fig.#3**. Fig. #3 shows RH Cross Rail. The pin stops and the hose guide brackets are some of the determining factor between the LH and RH Cross Rails. Both pin stops and hose guide brackets go to the inside of the lift. Also locate cross rail leaf chain (2 pcs.-ALIG-418-112, 212 1/4" long). Run chain through Cross Rail as shown in **Fig.#3**. Chain goes over the 2 1/4" pulley on the main side end, under the pulley at the offside end and thru the (ALIG-418-030-XX) Slack Chain Guide. Do the same for both Cross Rails. After routing chains through Cross Rails. Connect the end of the main side chains to the chain connector at the bottom of both Main side Columns using 5/16 x 1 1/4 shoulder bolt (2 pcs.-91259A585) and 1/4-20UNC nylon lock nut (2 pcs.-90640A129).
4. **IMPORTANT - Leaf chain must be mounted vertically on the chain connector to eliminate any chance of binding or kinking.**
5. Do this before moving the Cross Rail into the Main side Column weldment. Now move Cross Rail into the column to mount nylon rub blocks (3 pcs.-ALIG-412-019) and guide brackets (1/1 pc.-ALIG-418-093-XX & -096-XX). The ALIG-418-093-XX always goes to the outside of the lift and ALIG-418-096-XX always goes to the inside of the lift.
6. Move Cross Rail to the inside of the lift about an 1" off center and mount the double guide bracket with the rub block first. Slide rub blocks into each cut out of guide brackets (ALIG-418-093-XX) see **Fig. #5B**. Take the guide assembly to the top of the inside column and rotate the assembly so that it goes into the formed column see **Fig. #5C**. Slide it down the column and bolt it to the out side of the Cross Rail using 1/2-13UNC x 1 HHCS (2 pcs.-92865A712), 1/2 SAE Flat Washer (2 pcs.-90126A033) and 1/2 Lock Washer (2 pcs.-91102A033). Repeat the same procedure for Single Guide (ALIG-418-096-XX).
7. Repeat the same procedure on the opposite main side for the LH Cross Rails.
8. Locate the LH/RH Offside Columns shown in **Fig. #2**. LH Offside Column is shown. See **Fig. #5A** for location on lift assembly. Slide LH Offside Columns into the RH Cross Rail about 11'- 9 1/2" apart from the Main side at the base plate. Repeat the mounting procedure of the guide brackets (ALIG-418-093-XX & -096-XX) and the nylon rub blocks (ALIG-412-019). Guide brackets hold the Offside Column the correct distance from the Main side Column.

9. Connect the cross rail leaf chain on the offside to the Threaded Chain Connector (1 pc.–ALIG-415-049) see **Fig. #5D**. The chain should be routed thru the offside Slack Chain Guide (ALIG-418-030-XX). Use the 5/16 x 1 1/4 shoulder bolt (2 pcs.- 91259A585) and 1/4-20UNC nylon lock nut (2 pcs.– 90640A129) to connect the leaf chain to the chain connector. As the leaf chain is being tightened activate the Safety Slack Chain Device. To activated Safety Slack Chain Device hook the Safety Slack Chain Device on the inside of the Slack Chain Guide and tighten to take the slack out of the chain.
10. Repeat Step #5 & #6 of the RH Offside Column.
11. Move the Offside Columns apart to hold the (44018AR) 17'-0" or (44018XAR) 20'-0" dimension at the center to center of the columns and to anchor the columns to the concrete repeating Step #1.
12. Locate the LH/RH Track Weldm't. 1/1 pcs. (44018AR) ALIG-418-068L/R-X or (44018XAR) ALIG-418-268L/R-X and position them on top of the Cross Rails as shown in **Fig. #5E**. Hold 38 1/4" inside Track Weldm't. and centered on the Cross Rails side to side.
13. Connect the Top Rail chain to the Cross Rail Chain connector by extend hydraulic cylinder which lower both Top Rail Chain. Before the chain is connected to the Cross Rail connector the Safety Slack Chain Device must be activated. To activate Safety Slack Chain Device hook the Safety Slack Chain Device on the inside of the chain connector slot. Now connect the chain to the connector using the 3/8 x 1 1/2 lg. shoulder screw (2 pcs.–91259A628) and 5/16-18UNC nylon lock nut (2 pcs. – 90640A130).
14. Mount the 3-way pneumatic valve, F/R/L air system & power unit to the LH or RH Main side Column using the #8 socket head cap screw, #8 lock washer, 5/16-18UNC x 1" bolts, 5/16-18UNC hex nuts and 5/16 lock washers respectively see View A in **Fig. #6B**.
15. Install power unit on right rear column. Remove steel pressure port plug, #6 O-ring port on left side when facing controls. Use it to replace plastic shipping plug on the right side. Install 90 degree #6 O-ring x #6 JIC elbow (16167). On left side remove 3/8MNPT plug and replace with 90 degree 3/8 MNPT x #6 JIC elbow (68032).
16. Remove shipping plugs from hydraulic cylinder and manually extend cylinder rod end. Install (2) 90 degree 3/8 MNPT x #6 JIC elbow (68032).
17. Install 140" hydraulic hose (pressure hose) from hydraulic cylinder, port closest to rod end of hydraulic cylinder to port (recessed on manifold) closest to lowering valve handle on power unit.
18. Install 68" hydraulic hose (return hose) from hydraulic cylinder, port closest to fixed end to port (flush to manifold) farthest from lowering valve handle.
19. Have a certified electrician connect the power unit to a suitable electrical power source. The standard power unit is 1 phase, 208/230 volt, 60Hz requiring a dedicated 30 amp double poll, double throw circuit breaker to operate lift to full capacity. See wiring diagram below.
20. Fill power unit with 5 1/2 Gallons of clean 10wt anti-foam, anti-rust hydraulic oil or Dexron III ATF. **Do Not use Oils with Detergents.**
21. Raise lift with track and rest on latch bar about 30" to 36" to secure Tracks on the Cross Rails and assemble the remaining parts and hardware on the Tracks. Use **figure #4A, #4B and #4C**.
22. Assemble and install the air hoses and fitting as shown in **Fig. #6A and #6B**. **Note: 5/32" and 3/8" tube run thru the hose brackets in the rear Cross Rail and thru the holes underneath the Track Weldm't. Air pressure requirements: 100 psi minimum to 120 psi maximum.** Use 3/8" Heli Tube (ALIG-415-119) to wrap 1/8" & 3/8 tube together.

Again before operating lift visually inspect lift to make sure hoses are not rubbing on hardware or lift parts. Push button on power unit to raise lift until safety latches rise off the latch bar, then press the Pneumatic Valve and at the same time push release handle on the power unit to lower lift.

Raise lift about 60" and set safety latches on latch bar. Adjust latch bars on columns to set Track level. This is done by turning the 3/4-10UNC hex nut on the threaded rod of the latch bar.

Raise and lower lift repeatedly to purge air trapped in hydraulic lines and to adjust Cross Rails. Each Cross Rail must be synchronized as the lift moves up and down. Adjust Cross Rails by turning the 1" hex nut of the chain connector on the Offside Columns.

When fully lowered refill tank with hydraulic oil.

After lift is leveled and operating properly, pour grout between the base plate and the concrete floor to stabilize the lift. Do not use lift for 24 hours.

Owner/Operator Checklist

SAVE THESE INSTRUCTIONS deliver them to owner/user/employee along with other materials furnished with this lift.

Demonstrate the operation of the lift to the owner/operator and review correct and safe lifting procedures using the **Lifting It Right** booklet as a guide.

Complete the Installation Checklist/Warranty Validation questionnaire with the owner. Review the terms of the warranty registration card, and return the card and a copy of the questionnaires to:

Challenger Lifts, Inc.
200 Cabel Street
Louisville, KY. 40206

Safety Notices and Decals

This product is furnished with graphic safety warning labels, which are reproduced on page 3 of these instructions. Do not remove or deface these warning labels, or allow them to be removed or defaced. For your safety, and the safety of others, read and understand all of the safety notices and decals included.

Owner/Employer Responsibilities

The owner/employer's responsibilities as prescribed by ANSI/ALI ALOIM-2000, are summarized below. For exact wording refer to the actual standard provided with this manual in the literature pack.

The Owner/Employer shall insure that lift operators are qualified and that they are trained in the safe use and operation of the lift using the manufacturer's operating instructions; ALI/SM 93 -1, ALI Lifting it Right safety manual; ALI/ST-90 ALI Safety Tips card; ANSI/ALI ALOIM-2000, American National Standard for Automotive Lifts-Safety Requirements for Operation, Inspection and Maintenance; ALI/WL Series, ALI Uniform Warning Label Decals/Placards; and in case of frame engaging lifts, ALI/LP-GUIDE, Vehicle Lifting Points/Quick Reference Guide for Frame Engaging Lifts.

The Owner/Employer shall establish procedures to periodically inspect the lift in accordance with the lift manufacturer's instructions or ANSI/ALI ALOIM-2000, American National Standard for Automotive Lifts-Safety Requirements for Operation, Inspection and Maintenance; and the employer shall insure that the lift inspectors are qualified and that they are adequately trained in the inspection of the lift.

The Owner/Employer shall establish procedures to periodically maintain the lift in accordance with the lift manufacturer's instructions or ANSI/ALIOIM-2000, American National Standard for Automotive Lifts-Safety Requirements for Operation, Inspection and Maintenance; and the employer shall insure that the lift maintenance personnel are qualified and that they are adequately trained in the maintenance of the lift.

The Owner/Employer shall maintain the periodic inspection and maintenance records recommended by the manufacturer or ANSI/ALI ALOIM-2000, American National Standard for Automotive Lifts-Safety Requirements for Operation, Inspection and Maintenance.

The Owner/Employer shall display the lift manufacturer's operating instructions; ALI/SM 93 -1, ALI Lifting it Right safety manual; ALI/ST-90 ALI Safety Tips card; ANSI/ALI ALOIM-2000, American National Standard for Automotive Lifts-Safety Requirements for Operation, Inspection and Maintenance; and in the case of frame engaging lift, ALI/LP-GUIDE, Vehicle Lifting Points/Quick Reference Guide for Frame Engaging Lifts; in a conspicuous location in the lift area convenient to the operator. Demonstrate the operation of the lift to the owner and review correct and safe lifting procedure, using the "Lifting It Right " booklet as a guide.

Important Safety Instructions

When using your garage equipment, basic safety precautions should always be followed, including the following:

- a) Read all instructions.
- b) Care must be taken as burns can occur from touching hot parts.
- c) To reduce the risk of fire, do not operate equipment in the vicinity of open containers of flammable liquids (gasoline).
- d) Adequate ventilation should be provided when working on operating internal combustion engines.
- e) Keep hair, loose clothing, fingers, and all parts of body away from moving parts.
- f) To reduce the risk of electric shock, do not use on wet surfaces or expose to rain.
- g) Use only as described in this manual. Use only manufacturer's recommended attachments.

Save These Instructions

LIFTING A VEHICLE

Drive vehicle onto lift. Set parking brake and/or use wheel chocks that are provided with lift.

When the vehicle has reached the desired working height, release the power pack button, and lower the vehicle until the safety locks are engaged. The vehicle should remain level when all locks are engaged. If one side engages and the other continues to descend, stop lowering the vehicle, raise it several inches, and try again to engage locks.

IMPORTANT, Before walking under the lift insure that all locks are properly engaged.

It is not safe to work under the vehicle unless all locks are engaged, and the vehicle is level.

LOWERING A VEHICLE

Insure that the area under the vehicle is clear of personnel and tools.

Raise the vehicle until locks are free.

Disengage the locks by depressing the palm button and holding it.

Lower the vehicle by depressing the lowering valve handle. Watch lift to insure that the lift is lowering evenly. If not, raise lift and check all locks to insure they are disengaged before trying to lower lift again.

Continue to lower the vehicle until the crossbeams stop against the base plate. It is important to fully lower the lift to release hydraulic pressure on the system.

MAINTENANCE

To avoid personal injury, permit only qualified personnel to perform maintenance on this equipment. The following maintenance points are suggested as the basis of a preventive maintenance program. The actual maintenance program should be tailored to the installation. See ANSI/ALI ALOIM booklet for periodic inspection checklist and maintenance log sheet.

- If lift stops short of full rise or chatters, check fluid level and bleed cylinder per Installation Instructions.
- Replace all Safety, Warning or Caution Labels if missing or damaged.

Daily

- Keep lift components clean. **To keep alignment lifts with rear slip plates working properly use compressed air to blow out any debris from the bearing area.**
- Check for loose or broken parts.
- Check hydraulic system for fluid leaks.
- Check lock release activation.

Weekly

- Check chains and sheaves for wear or damage. Replace as required with genuine Challenger Lifts parts.
- Inspect lock mechanism for proper function.

Monthly

- Torque concrete anchor bolts to 80 ft-lbs.
- Clean and inspect chains and sheaves for wear or damage. Lubricate chain and sheaves with light oil.

IMPORTANT ! Failure to keep lift free of corrosive agents and solvents will lead to reduced service life, which could result in property damage and/or personal injury. If any problems are encountered, contact your local service representative.

Parts & Shipping List

<u>Part Number</u>	<u>Description</u>	<u>Qty</u>	
Ramp Assembly		1	
ALIG-418-081-XX	1/2 SAE Flat Washer	24	
5304ZZ	52 O.D. x 20 I.D. x 22W DS Bearing	2	
98410A128	0.75 Dia. Retainer Ring	6	
ALIG-418-106	3/4 Dia. Ramp Pins	2	
Top Rail Assembly		1	
ALIG-418-036-XX	44018AR Top Rail Weldment	1	
(ALIG-418-236-XX)	44018XAR Top Rail Weldment	1	
ALIG-418-101	Cylinder Chain Connector	1	
ALIG-418-109	1 Dia. Cylinder Pin	1	
ALIG-418-111	1 3/8 Dia. Pulley Pin	1	
ALIG-418-113	BL844, 99 pitch, Std, Short Top Rail Chain	1	
ALIG-418-114	BL844, 291 pitch, 44018AR, Lg Top Rail Chain	1	
(ALIG-418-214)	BL844, 327 pitch, 44018XAR, Lg Top Rail Chain	1	
ALIF-418-120	0.375FJICS Hose x 140" lg	1	PKG
ALIF-418-121	0.375FJICS Hose x 68" lg	1	PKG
AA4015001	4.9 Dia. 72" Stroke Hydraulic Cylinder	1	
GL-12-053	5.5 Dia. Roller	2	
GL-12-056	4.0 Dia. Pulley	3	
2501-06-06	0.375MNPT x 0.375MJIC 90 Deg. Adapter	2	HK
3225T6	3/4" Rubber Cushion Steel Loops (Optional)	6	HK
6801-LL-06-06	0.375MORB x 0.375MJIC 90 Deg. Adapter w/O-ring	2	HK
7130K55	11" Black Ties	12	HK
90473A223	1/2-13UNC Hex Nut Grd. 2	4	HK
90126A033	1/2 SAE Flat Washer	8	HK
91102A033	1/2 Lock Washer	4	HK
91247A720	1/2-13UNC x 2.0 HHCS Grd 5	4	HK
98023A045	2.00 SAE Flat Washer	2	
98381A634	0.375 Dia. X 2.5 lg. Dowel Pin	2	
98410A133	1.000 Dia. Retaining Ring	1	
98410A152	2.000 Dia. Retaining Ring	2	
98410A249	1.375 Dia. Retaining Ring	3	

Parts & Shipping List

<u>Part Number</u>	<u>Description</u>	<u>Qty</u>
LH/RH Cross Rail Assembly		1/1
ALIG-418-025L/R-X	LH/RH Cross Rail Weldment	1/1
ALIG-418-019L/R-X	LH/RH CR Cover Plate	2/2
ALIG-418-021L/R-X	LH/RH Safety Locks	2/2
ALIG-418-107	7/8 Dia. Chain Connection Pin	2
ALIG-418-107A	7/8 Dia Chain Connection Pin	2
ALIG-412-089	1 Dia Safety Latch Pin	4
ALIG-418-023	Machine Chain Connector 3"lg (LH Cross Rail)	2
ALIG-418-024-XX	Safety Latch Spacer	4
ALIG-418-026-XX	Safety Slack Chain	4
ALIG-418-030-XX	Slack Chain Guide	2
ALIG-418-093-XX	Double Guide Bracket	4
ALIG-418-096-XX	Single Guide Bracket	4
ALIG-412-019	Nylon Rub Blocks	12 PKG
ALIG-412-088	3/4 Dia Pulley Pin	4
C1100-112-4500M	1.10 OD x 0.125W Compression Spring	4
CUHC105002TAP727E	#10-24 Hex Head Thread Cutting Screw	16
GL-12-055	2.25 Dia. Pulley	4
SPC-2501	1/8 MNPT x 5/32 Push-On Fitting	4
5315	0.375 Dia. X 0.41W x 1.00lg Extension Spring	4
6498K334-1.00	0.75 Dia. X 1.0 Stroke Pneumatic Cylinder	4
6498K42	0.75 Dia. Cylinder Yokes	4
6498K72	0.75 Dia. Cylinder Brackets	4 Sets
91251A542	1/4-20UNC x 1.0lg SHCS	4
91251A546	1/4-20UNC x 1.5lg SHCS	4
90473A029	1/4-20UNC Hex Nut Grd. 2	4
90126A038	1" SAE Flat Washer	4
91102A029	1/4 Lock Washer	4
98410A128	0.750 Dia. Retainer Ring	4
98410A131	0.875 Dia. Retainer Ring	4
98410A133	1.000 Dia. Retainer Ring	4

Parts & Shipping List

<u>Part Number</u>	<u>Description</u>	<u>Qty</u>
91309A537	1/4-20UNC x 0.50lg HHCS Grd 2	8
91259A585	0.313 Dia. 1.25 lg Shoulder Bolt	4 HK
91259A628	0.375 Dia 1.50 lg Shoulder Bolt	2 HK
90640A129	1/4-20UNC Nylon Lock Nut	4 HK
90640A130	5/16-18UNC Nylon Lock Nut	2 HK
92865A712	1/2-13UNC x 1.00 lg. HHCS Grd 2	16 HK
90126A033	1/2 SAE Flat Washer	16 HK
91102A033	1/2 Lock Washer	16 HK
LH/RH Mainside Column Assembly		1/1
LH/RH Offside Column Assembly		1/1
ALIG-418-005L/R-X	LH/RH Offside Column	1/1
ALIG-418-006L/R-X	LH/RH Mainside Column	1/1
ALIG-418-012-XX	Latch Bar Weldment	4
90473A242	7/8-9UNC Hex Nut Grd. 2	8
90126A033	1/2 SAE Flat Washer	8 HK
90473A233	1/2-13UNC Hex Nut Grd. 2	20 HK
91247A583	5/16-18UNC x 1.0 lg HHCS Grd. 5	6 HK
90473A030	5/16-18UNC Hex Nut Grd. 2	10 HK
91102A009	#8 Lock Washer	3 HK
91102A030	5/16 Lock Washer	6 HK
91102A033	1/2 Lock Washer	6 HK
91251A199	#8-32 x 1.0 lg SHCS	3 HK
91578A501	3/4-10UNC x 5.0 lg Anchor Bolts	16 HK
92865A714	1/2-13UNC x 1.25 lg HHCS Grd 5	4 HK
92865A720	1/2-13UNC x 2.0 lg (Full Thrd) HHCS Grd 5	16 HK
9486A555	1-14UNF Hex Nut Grd. 5	4
ALIG-415-049	Threaded Chain Connector	2 PKG
12087-19	Power Unit	1

Parts & Shipping List

<u>Part Number</u>	<u>Description</u>	<u>Qty</u>
LH/RH Track Assembly		1/1
ALIG-418-068L/R-X	44018AR LH/RH Track Weldment	1/1
(ALIG-418-268L/R-X)	44018XAR LH/RH Track Weldment	1/1
ALIG-418-046	0.25 x 4.00 x 71.50 CDFB, 1018	4 PKG
ALIG-418-067-X	Turn Table Stops	8 PKG
ALIG-418-071-X	Turn Table Cover Weldment	2 PKG
ALIG-418-073-X	16 Ga. MSSH x 7.50 x 35.00, A569	8 PKG
ALIG-418-074-X	Slip Plate Weldment	4 PKG
ALIG-418-085-X	Ramp Support Weldment	2 PKG
ALIG-418-090-X	Front Stop Weldment	2 PKG
ALIG-418-098-X	Pneumatic Bracket	1 PKG
ALIG-418-099-X	Electrical Box Bracket	1 PKG
ALIG-418-106	Ramp Pivot Pin	2 PKG
ALIG-418-008	Slip Plate Pin	8 PKG
ALIG-418-093	Track Steps	2 PKG
ALIG-418-099	1/2-13UNC x 3.25 x 6.50 U-Bolts	4 PKG
3896T1	1/16 Oval Sleeve Aluminum Ferrules	16 PKG
3461T82	1/16 Wire Rope (8 pcs – 12" lg)	8 FT
6970T65	Anti-Slip Tape x 12"	4 PKG
90473A223	1/2-13UNC Hex Nut Grd. 2	40 HK
90473A031	3/8-16UNC Hex Nut Grd. 2`	2 HK
90473A036	3/4-10UNC Hex Nut Grd. 2	10 HK
90566A031	3/8-16UNC Thin Nylon Lock Nut	8 HK
91090A115	3/8 Fender Washer x 1 1/2 O.D.	16 HK
91102A011	#10 Lock Washer	10 HK
91102A031	3/8 Lock Washer	2 HK
91102A033	1/2 Lock Washer	40 HK
91102A036	3/4 Lock washer	10 HK
91251A244	#10-24 x 0.63 lg. SHCS	12 HK
91251A623	3/8-16UNC x 0.88 lg. SHCS	2 HK
92865A714	1/2-13UNC x 1.25 lg. HHCS Grd. 5	4 HK

Parts & Shipping List

<u>Part Number</u>	<u>Description</u>	<u>Qty</u>	
92865A716	1/2-13UNC x 1.50 lg. HHCS Grd.5	28	HK
92865A841	3/4-10UNC x 1.75 HHCS Grd 5	10	HK
93548A648	3/8-16UNC Carriage Bolt x 6 lg.	8	HK
9614K37	1.0 dia. Delrin Ball	72	HK
 Miscellaneous Parts			
90126A033	1/2 SAE Flat Washer	24	
90473A223	1/2-13UNC Hex Nut Grd. 2	12	
91102A033	1/2 Lock Washer	12	
91236A724	1/2-13UNC x 3.0 HHCS Grd. 5	4	
92865A718	1/2-13UNC x 1.75 HHCS Grd. 5	8	
CUHC105002TAP727E	#10-24 Hex Head Thread Cutting Screws	4	HK
SPC-2501	1/8 MNPT x 5/32 Push-On Fitting (Plastic)	2	HK
SPE-25	5/32 Push-On Union Tee (Plastic)	3	HK
SPC-6002	1/4 MNPT x 3/8 Push-On Fitting (Plastic)	11	HK
SPE-60	3/8 Push-On Union Tee (Plastic)	9	HK
414411000	3-Way Pneumatic Valve	1	HK
42035	F/R/L Air System	1	HK
4534K42	1/4 NPTF FM Seal Hex Soc Plug (ALIF-209 Cyl.)	1	HK
47865K21	1/4 FNPT x 1/4 FNPT Ball Valve (Brass)	1	HK
50785K41	1/8 MNPT x 1/8 FNPT 90 deg. Strt Elbow (Brass)	1	HK
50785K61	1/8 MNPT x 1/8 FNPT Hex Bushing (Brass)	1	HK
50785K72	1/4 FNPT Tee Connector (Brass)	1	HK
5245K12	1/4 MNPT x 1/4 Self Retracting Nylon Air Hose 25'	2	HK
5485K22	1/4 MNPT x 1/4 MNPT Hex Nipple (Brass)	2	HK
6536K18	1/4 MNPT x 1/4 F Quick Disconnect Hose coupling	10	HK
ALIG-418-112	BL644, 283 Pitch, Cross Rail Chain, 212.25"	2	PKG
PT23003BK	5/32 OD Black Tube	47	PKG
PT24006BK	3/8 OD Black Tube	60	PKG
ALIG-415-119	6'-HT-00375-3/8 Heli Tube	1	PKG

***Note: All hardware unless specified is grade 2. All hardware is zinc coated unless specified. Parts with PKG at the end are packed on the lift and parts with HK at the end are packaged in a box and put on the lift.

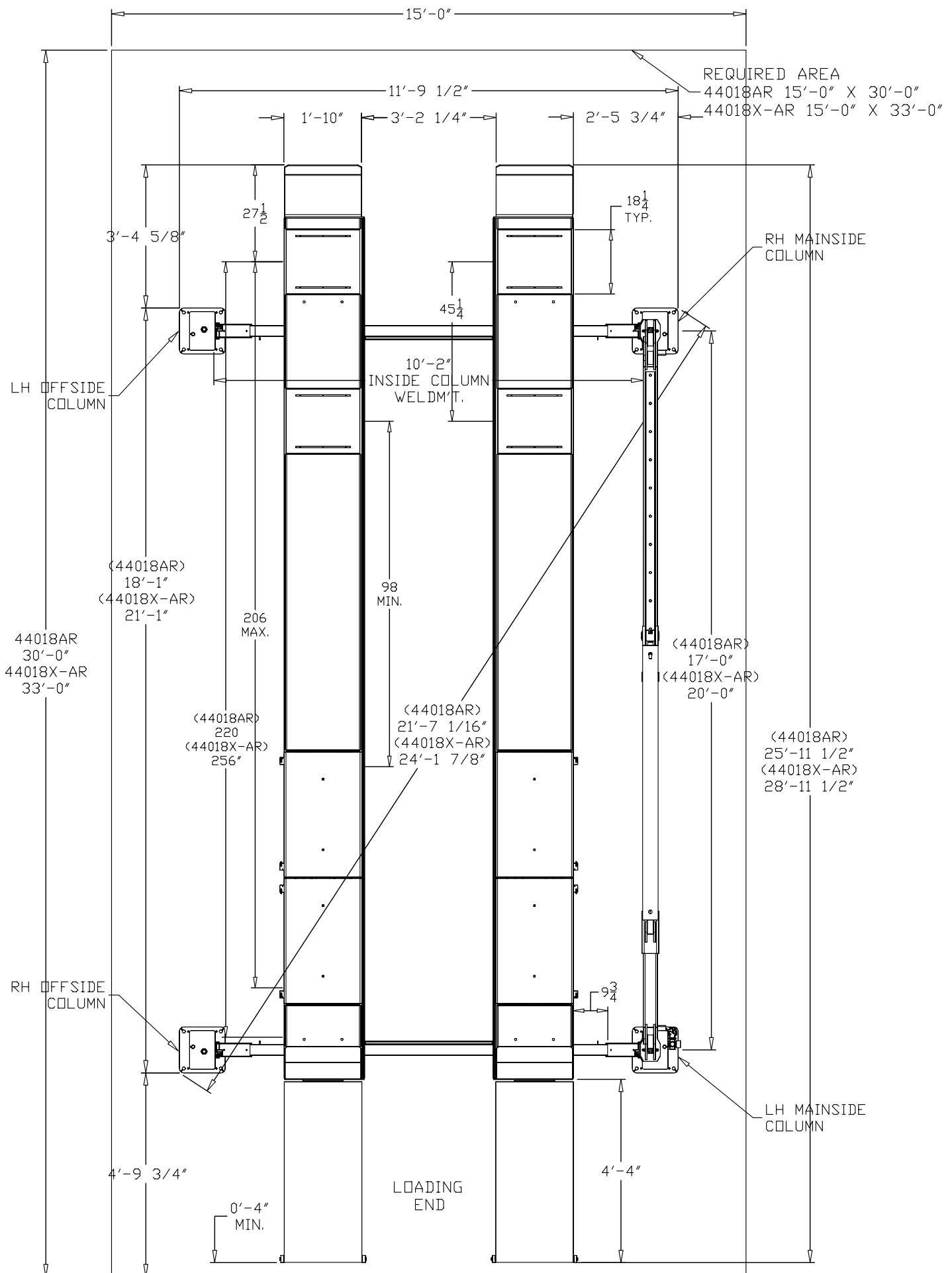

44018AR & 44018X-AR
 LAYOUT & INSTALLATION SPECIFICATION

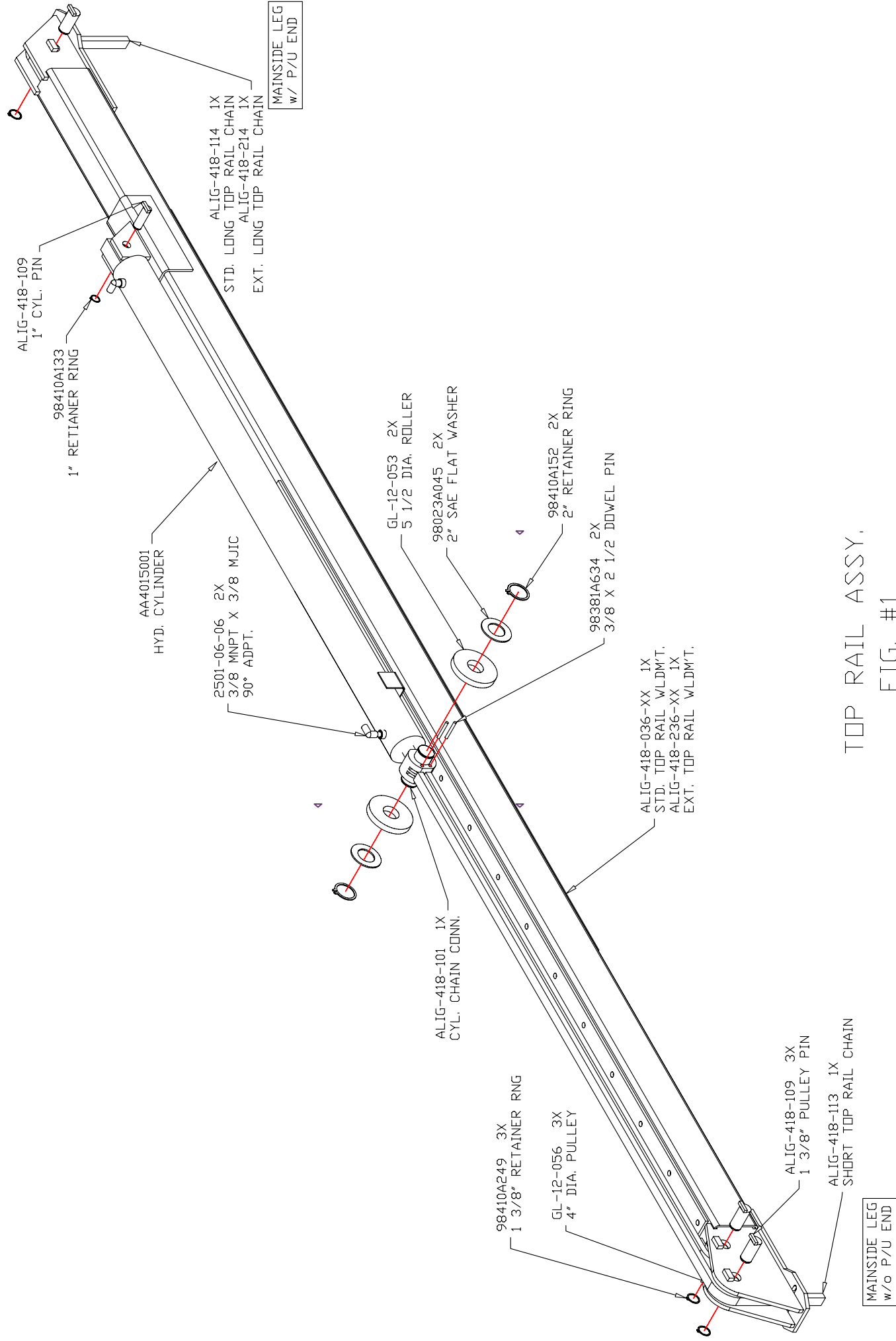

TOP RAIL ASSY.
FIG. #1

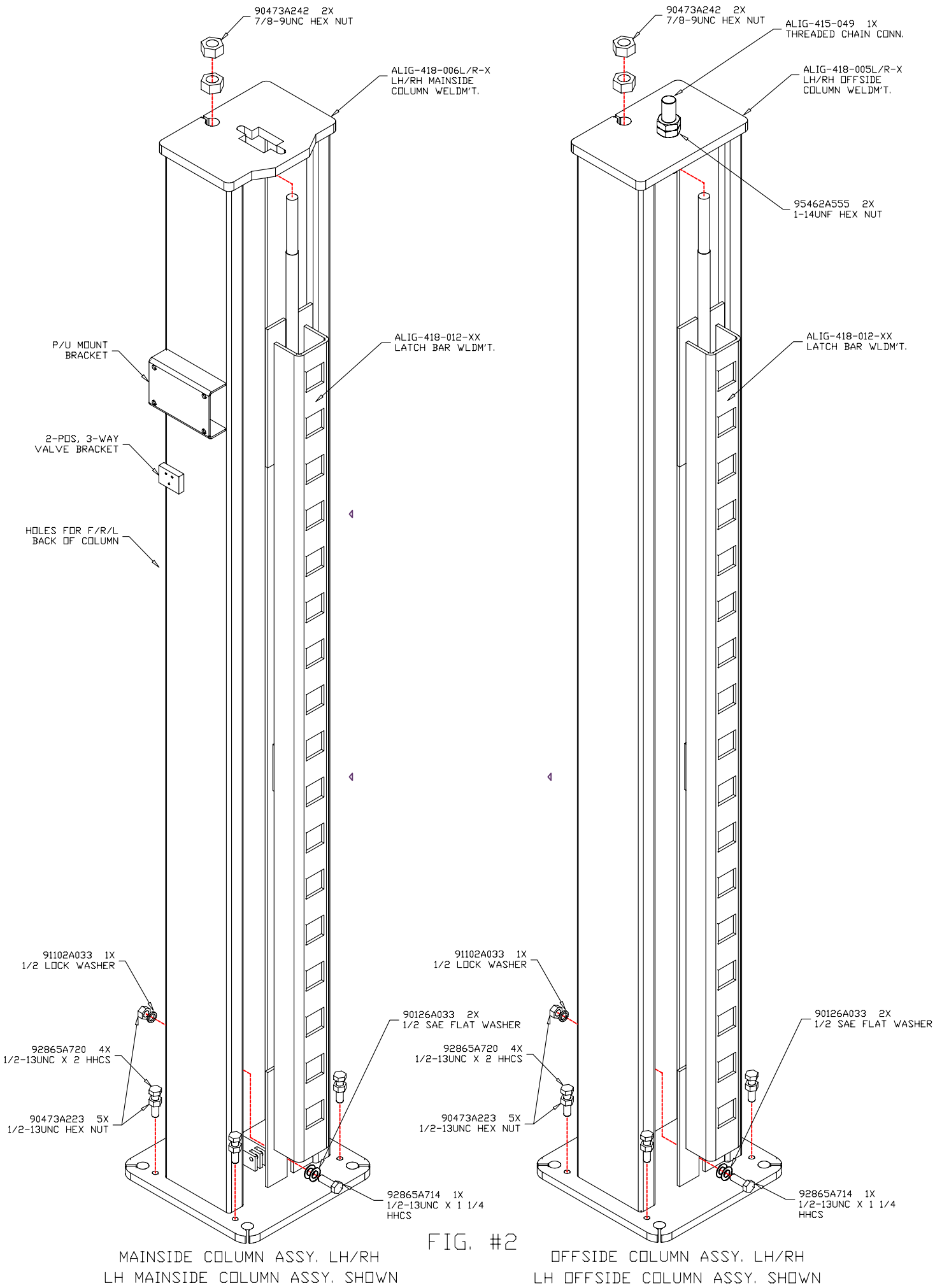

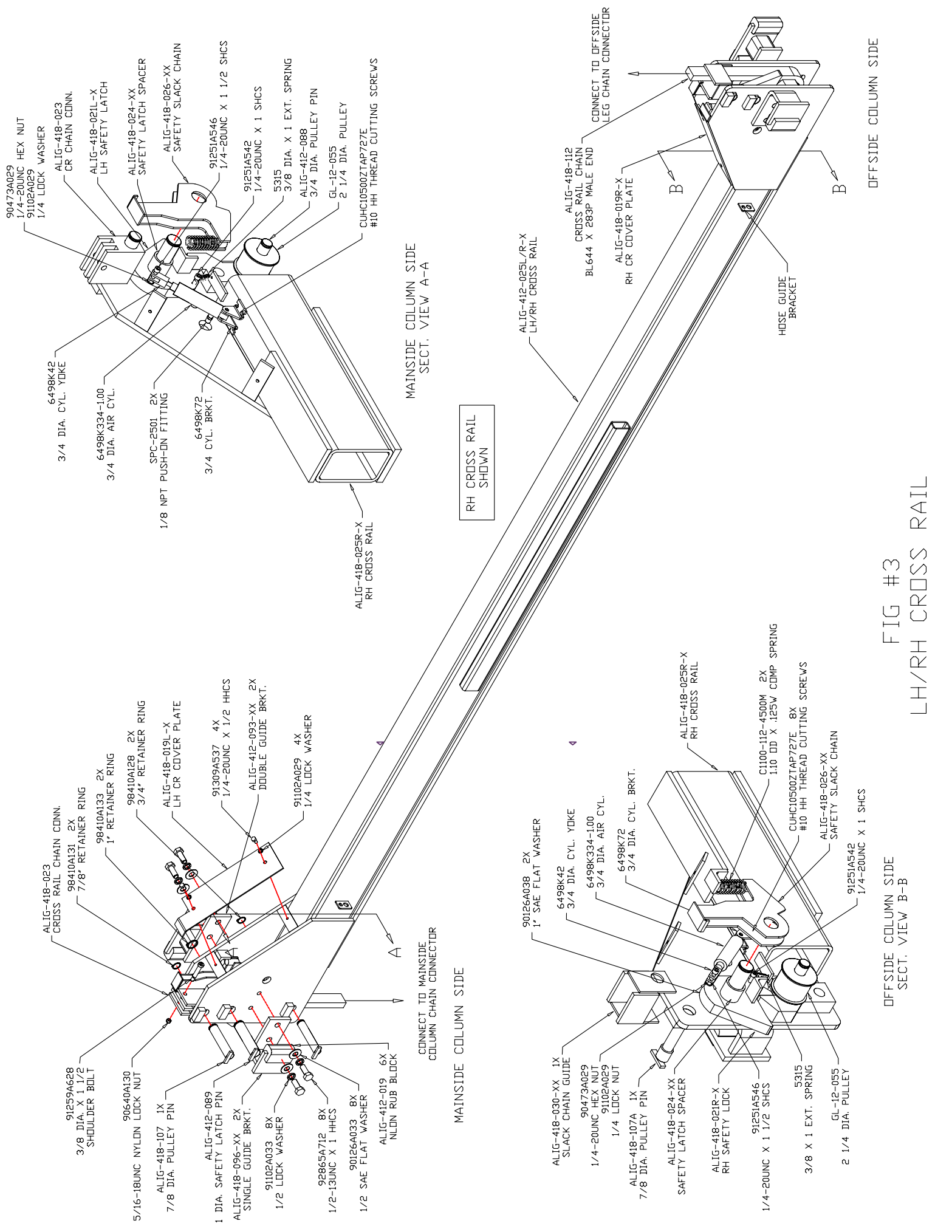

FIG #3
LH/RH CROSS RAIL

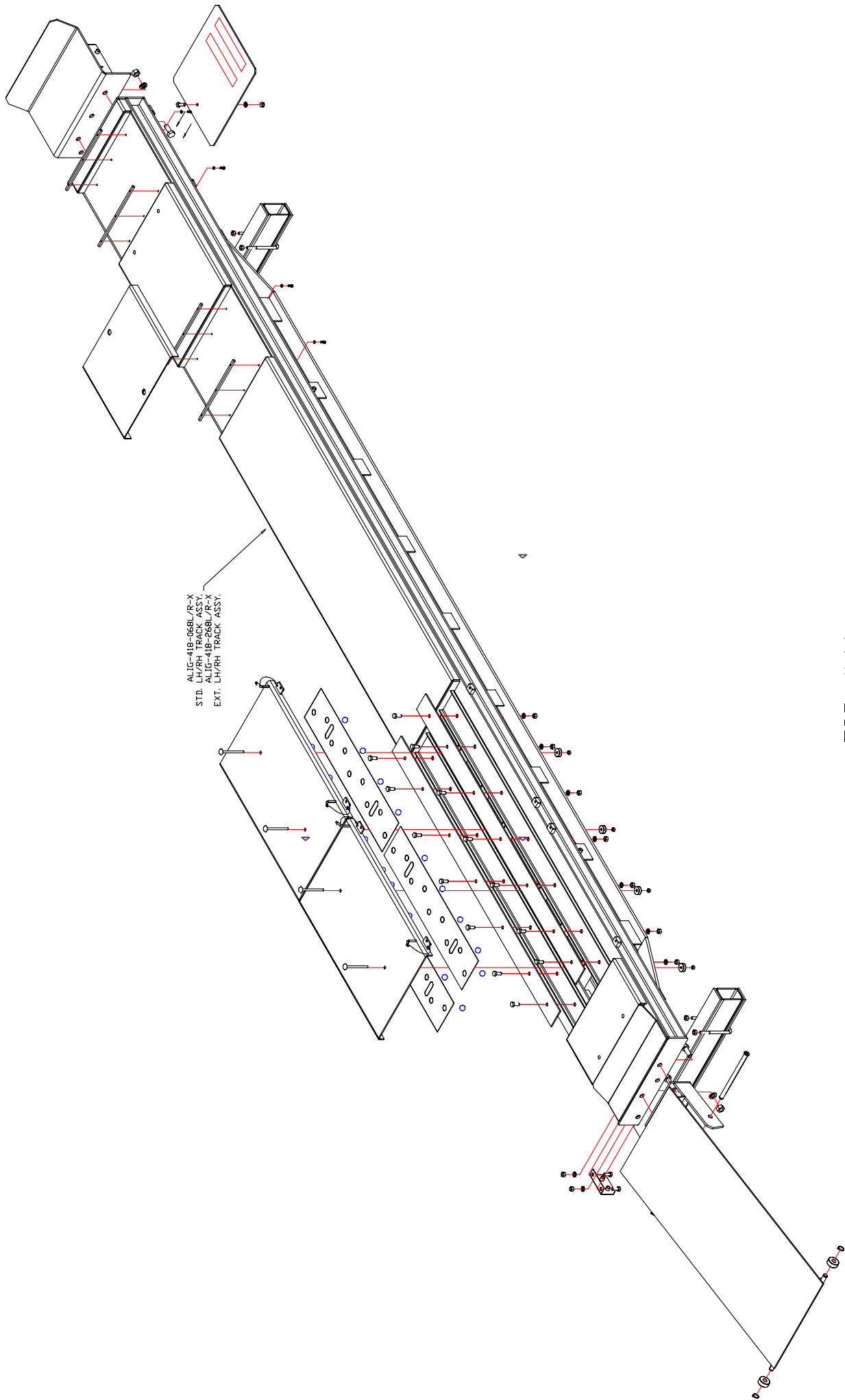

FIG. #4A
TRACK ASSY.

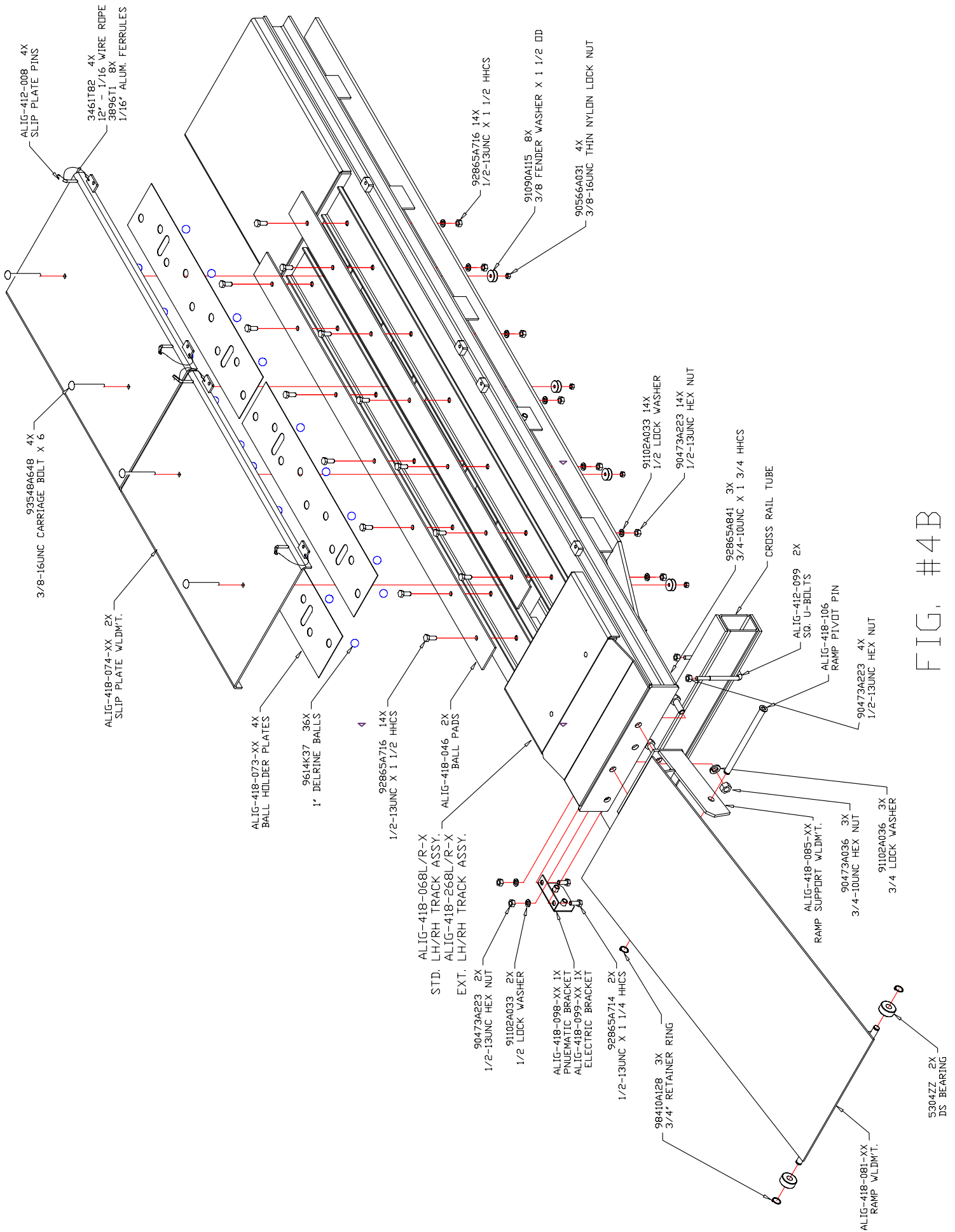

FIG. #4B

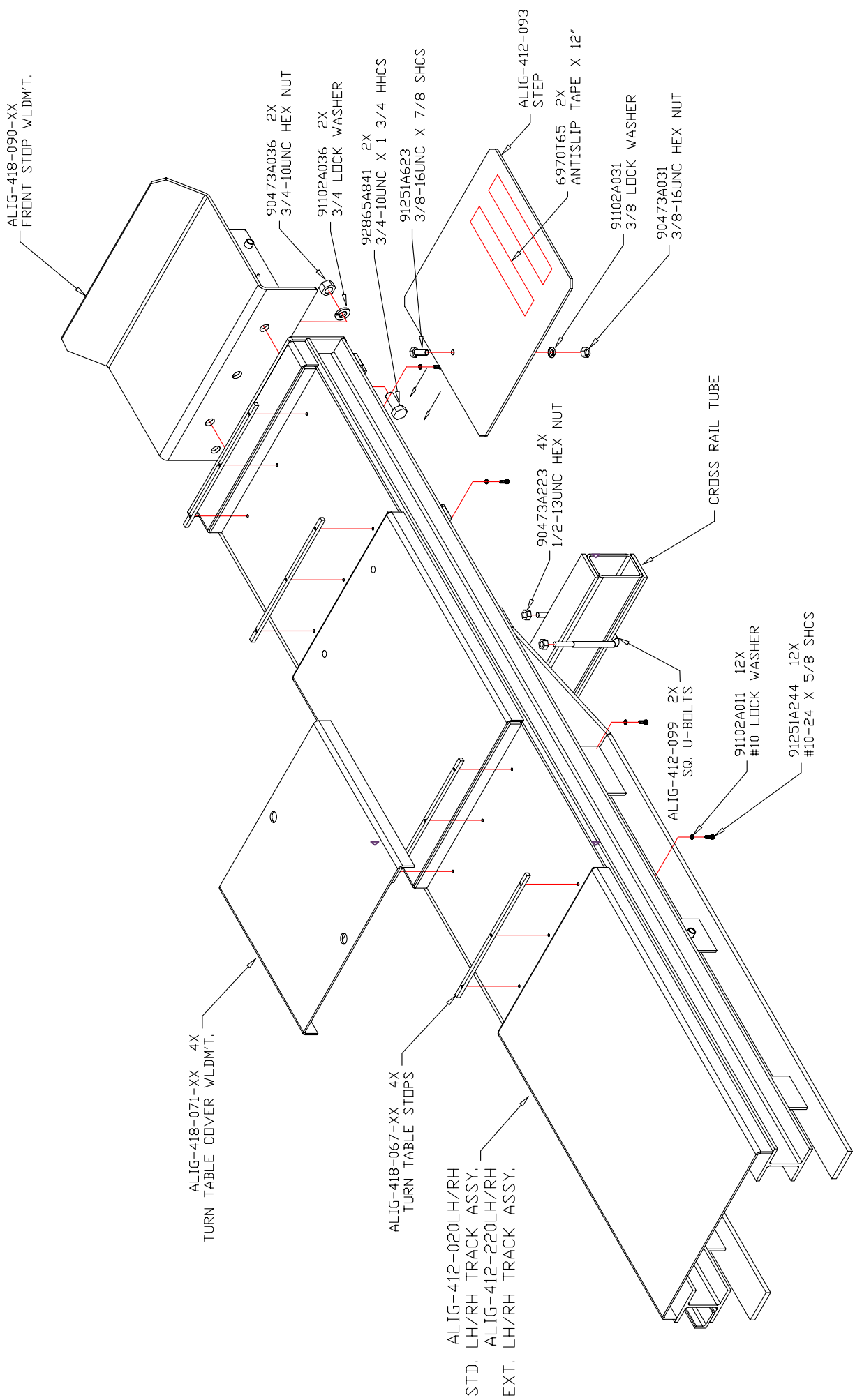
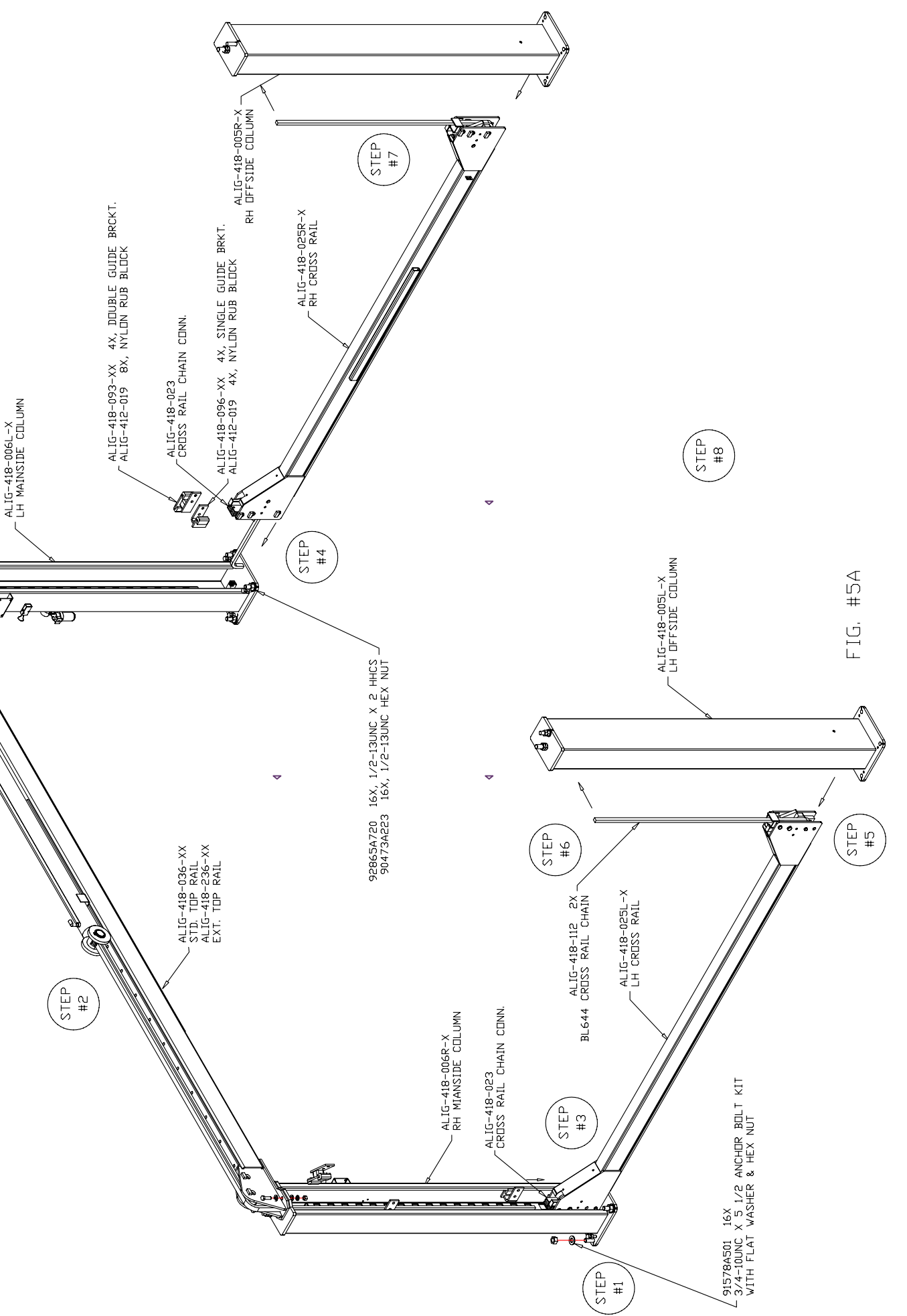

FIG. #4C

91247A720 4X, 1/2-13UNC X 2 HHCS
 90126A033 8X, 1/2 FLAT WASHER
 91102A033 4X, 1/2 LOCK WASHER
 90473A223 4X, 1/2-13UNC HEX NUT

*NOTE:
 -POWER UNIT CAN BE MOUNTED ON EITHER MAINSIDE COLUMN.
 MAINSIDE COLUMNS CAN BE LOCATED ON EITHER SIDE OF LIFT.
 IF MAINSIDE COLUMNS ARE SWITCHED TO OPPOSITE SIDE OF
 LIFT THEN CROSS RAILS MUST ALSO BE CHANGED IN RESPECT.
 -THE ROUTING OF THE HYDRAULIC AND AIR LINES CHANGE
 DEPENDING ON WHERE THE POWER UNIT IS LOCATED AND
 WHICH SIDE THE MAINSIDE COLUMNS ARE LOCATED ACCORDING
 TO THE LIFT.



ALIG-418-006L-X
 LH MAINSIDE COLUMN

ALIG-418-093-XX 4X, DOUBLE GUIDE BRCKT.
 ALIG-412-019 8X, NYLON RUB BLOCK

ALIG-418-023
 CROSS RAIL CHAIN CONN.

ALIG-418-096-XX 4X, SINGLE GUIDE BRCKT.
 ALIG-412-019 4X, NYLON RUB BLOCK

ALIG-418-005R-X
 RH OFFSIDE COLUMN

ALIG-418-025R-X
 RH CROSS RAIL

STEP #4

92865A720 16X, 1/2-13UNC X 2 HHCS
 90473A223 16X, 1/2-13UNC HEX NUT

ALIG-418-036-XX
 STD. TOP RAIL
 ALIG-418-236-XX
 EXT. TOP RAIL

ALIG-418-006R-X
 RH MAINSIDE COLUMN

ALIG-418-023
 CROSS RAIL CHAIN CONN.

STEP #6

ALIG-418-112 2X
 CROSS RAIL CHAIN

ALIG-418-025L-X
 LH CROSS RAIL

STEP #3

91578A501 16X
 3/4-10UNC X 5 1/2 ANCHOR BOLT KIT
 WITH FLAT WASHER & HEX NUT

ALIG-418-005L-X
 LH OFFSIDE COLUMN

STEP #8

STEP #1

STEP #5

FIG. #5A

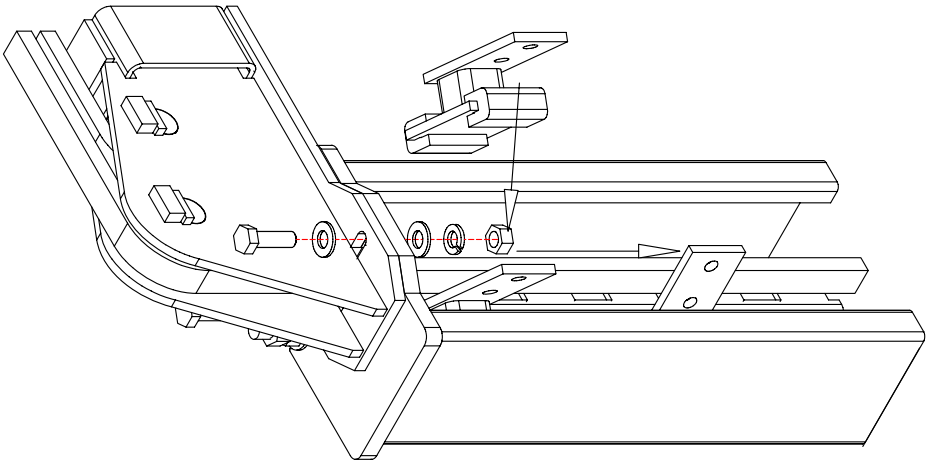

FIG. #5C

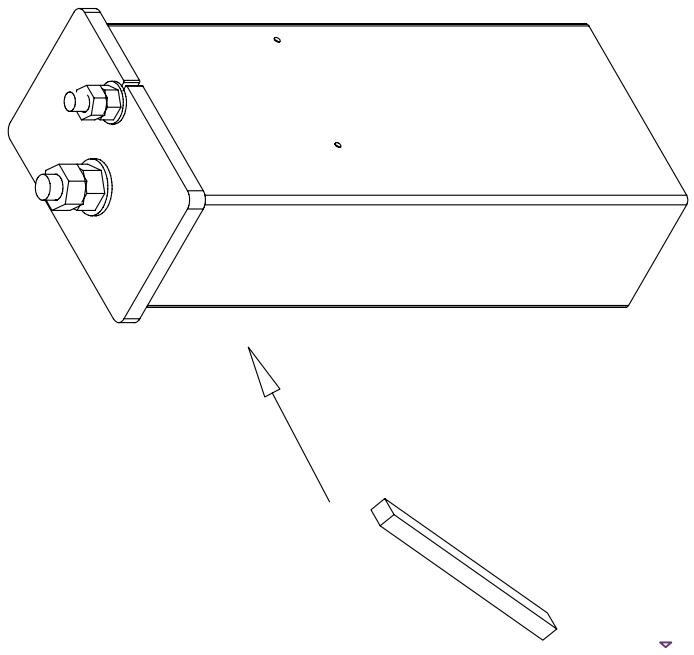

FIG. #5D

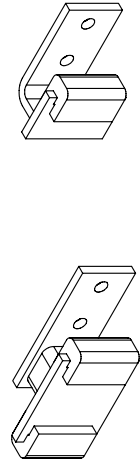

FIG. #5B

*NOTE:
 -POWER UNIT CAN BE MOUNTED ON EITHER MAINSIDE COLUMN.
 MAINSIDE COLUMNS CAN BE LOCATED ON EITHER SIDE OF LIFT.
 IF MAINSIDE COLUMNS ARE SWITCHED TO OPPOSITE SIDE OF
 LIFT THEN CROSS RAILS MUST ALSO BE CHANGED IN RESPECT.
 -THE ROUTING OF THE HYDRAULIC AND AIR LINES CHANGE
 DEPENDING ON WHERE THE POWER UNIT IS LOCATED AND
 WHICH SIDE THE MAINSIDE COLUMNS ARE LOCATED ACCORDING
 TO THE LIFT.

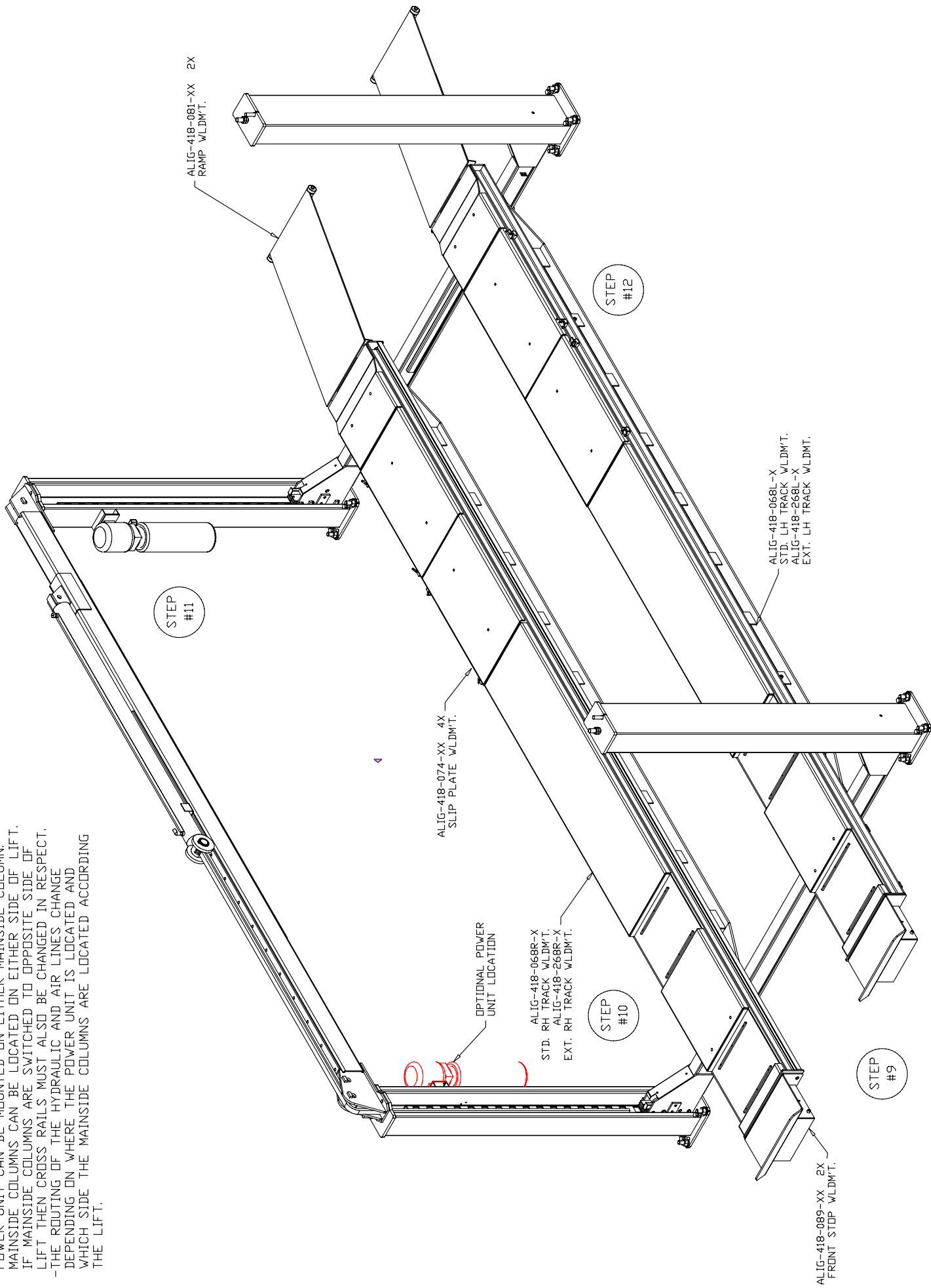

FIG. #5E

*NOTE:
 THIS IS THE RECOMMENDED CONFIGURATION FOR THE AIR
 AND HYDRAULIC LINES, BUT THE CONFIGURATION COULD
 VARY DEPENDING ON CUSTOMER PREFERENCE. POWER UNIT
 CAN BE MOUNTED ON EITHER MAIN SIDE COLUMN.

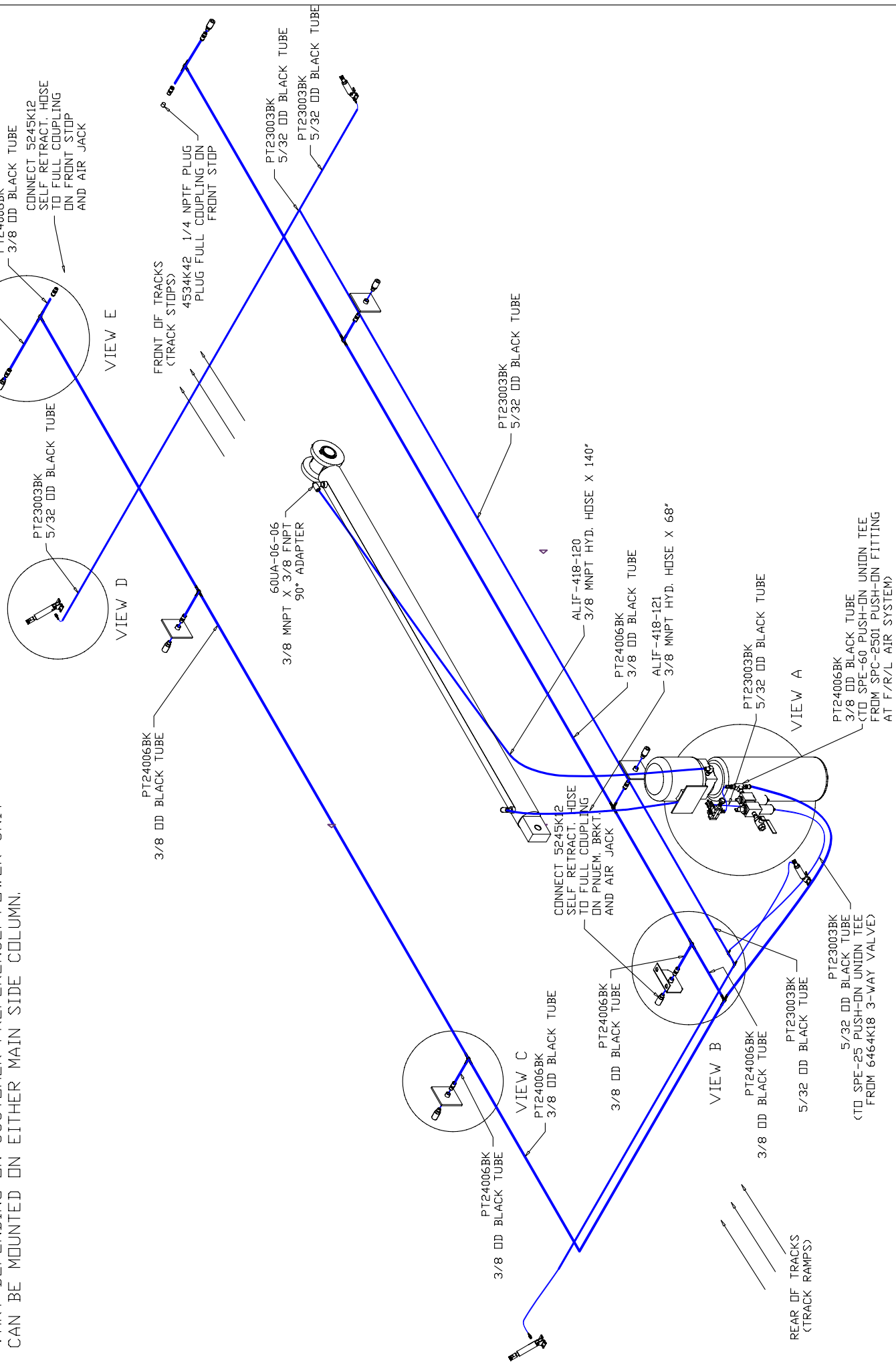
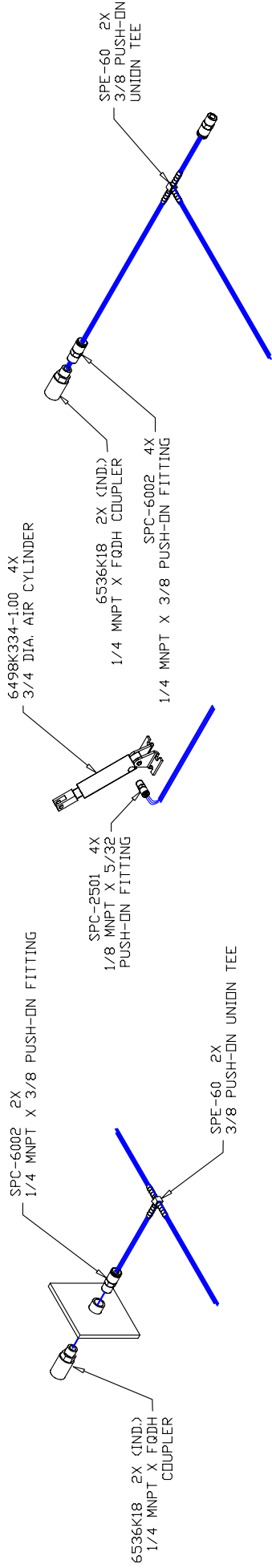

FIG #6A



VIEW C

VIEW D

VIEW E



VIEW B

VIEW A

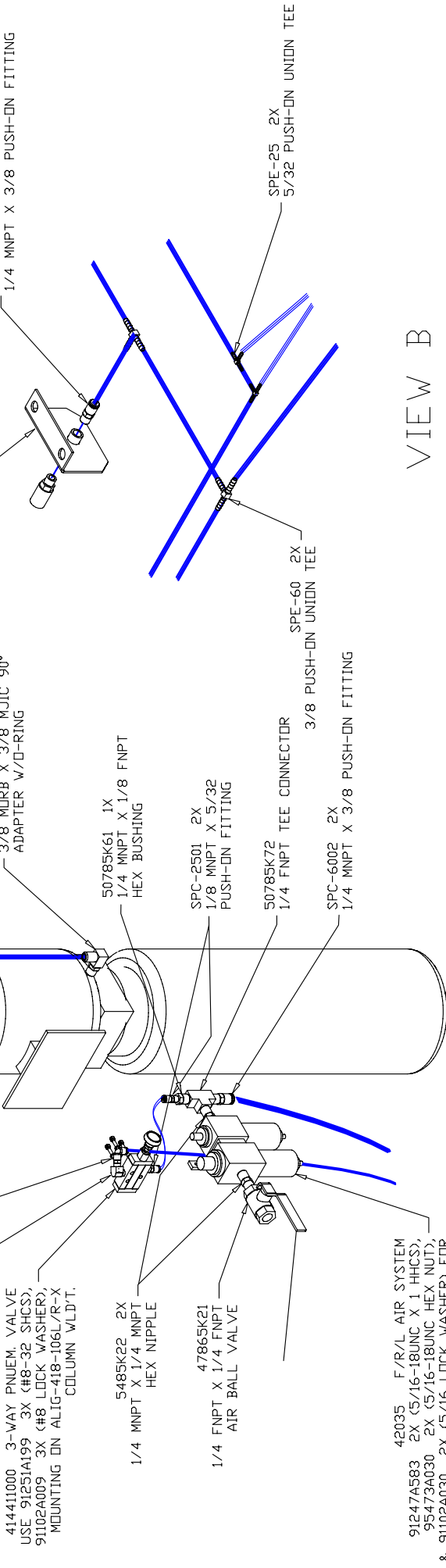

VIEW A

VIEW B

VIEW D

VIEW E

FIG #6B