

## Questionnaire for Price Quotation for a Moveable Trash Rack Cleaner

### I. Contact Data

PROJECT NAME   
(please reference on all correspondence)

PROJECT SITE   
(location and country)

Contact name  Company

Address

ZIP code / City   Country

Phone  Mobile

E-mail  Web

Developer  Consulting Agency Name of Project Owner

### II. Status

Feasibility study  Contract pending; construction scheduled for:

Public tender  Deadline for submitting an offer:

Construction of a new power plant  Modernisation of an existing plant

### III. Technical data

A Screen inclination  °

B Screen pedestal  mm

C Roof projection  mm

D Height of roof  mm

E Height of apron  mm

G Distance to gate  mm

H Height of pedestal  mm

L Screen length  mm

T Water depth min.  mm  
max.  mm

Tension  V

Frequency  Hz

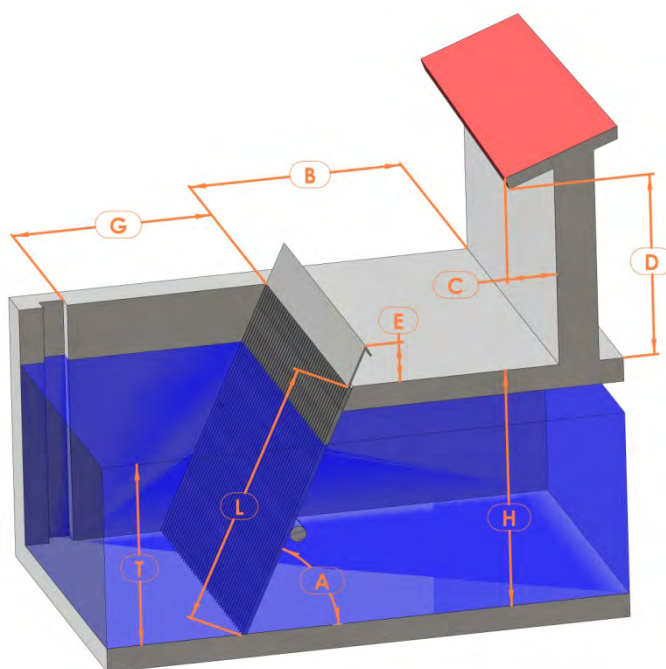

Outside temperature between -10°C and +40°C  yes  no; temperature from  °C to  °C

Screening disposal  Container with base flap  Returnable container  
 Conveyor  Wash-out channel

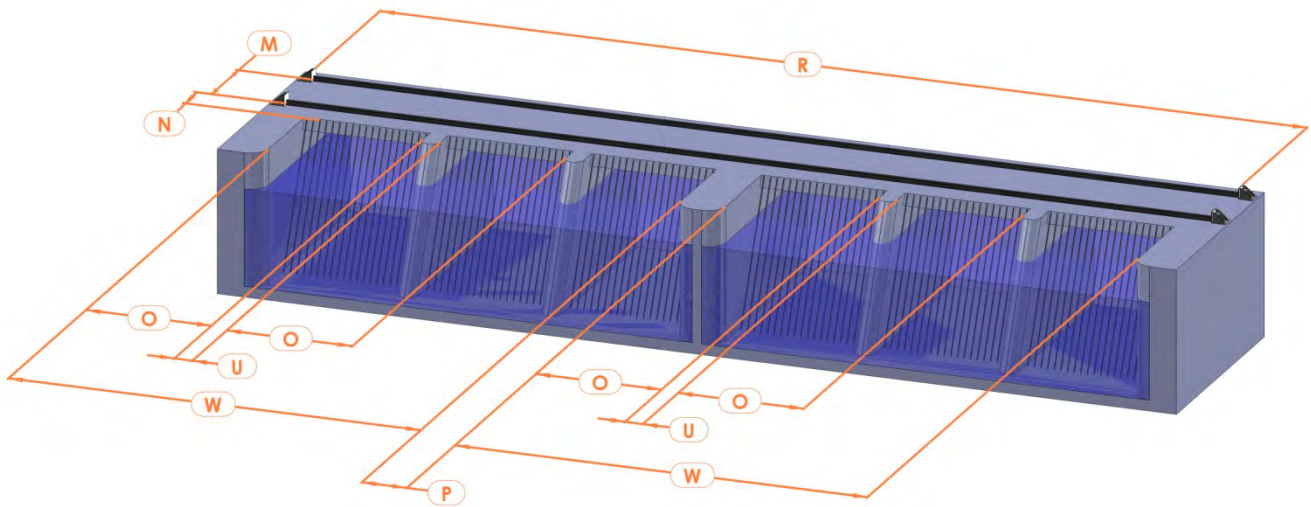

W Inlet width  mm

Number of inlets W

O Screen width  mm

Number of screens O per inlet W

P Concrete wall width  mm  
between the individual inlets

U Partition wall width  mm  
between the individual screens

Spacing of screen bars  mm

M Distance of rails  mm

N Distance of rail  mm  
to front edge of screen

R Rail length  mm

X Rail width  mm

Y Rail height  mm

Type of rail

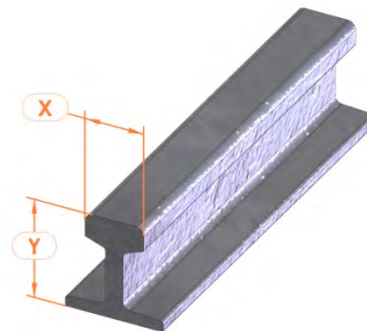

IV. Comments

Date, place

Signature