

# Dynamics-Newton's 1st Law

1. As shown in the diagram, an open box and its contents have a combined mass of 5.0 kilograms. A horizontal force of 15 newtons is required to push the box at a constant speed of 1.5 meters per second across a level surface.

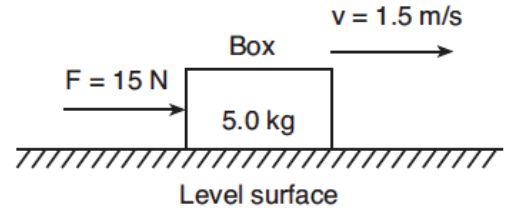

The inertia of the box and its contents increases if there is an increase in the

- speed of the box
  - mass of the contents of the box
  - magnitude of the horizontal force applied to the box
  - coefficient of kinetic friction between the box and the level surface
- 
2. Which unit is equivalent to a newton per kilogram?
- $\text{m/s}^2$
  - $\text{W/m}$
  - $\text{J}\cdot\text{s}$
  - $\text{kg}\cdot\text{m/s}$
3. Which object has the most inertia?
- A 0.001-kilogram bumblebee traveling at 2 meters per second
  - A 0.1-kilogram baseball traveling at 20 meters per second
  - A 5-kilogram bowling ball traveling at 3 meters per second
  - A 10-kilogram sled at rest
4. If the sum of all the forces acting on a moving object is zero, the object will
- slow down and stop
  - change the direction of its motion
  - accelerate uniformly
  - continue moving with constant velocity
5. The mass of a high school football player is approximately
- $10^0$  kg
  - $10^1$  kg
  - $10^2$  kg
  - $10^3$  kg
6. Which object has the greatest inertia?
- A 5-kg mass moving at 10 m/s
  - A 10-kg mass moving at 1 m/s
  - A 15-kg mass moving at 10 m/s
  - A 20-kg mass moving at 1 m/s
7. The data table below lists the mass and speed of four different objects
- Data Table**
- | Object | Mass (kg) | Speed (m/s) |
|--------|-----------|-------------|
| A      | 4.0       | 6.0         |
| B      | 6.0       | 5.0         |
| C      | 8.0       | 3.0         |
| D      | 16.0      | 1.5         |
- Which object has the greatest inertia?
- A
  - B
  - C
  - D
8. A 0.50-kilogram cart is rolling at a speed of 0.40 meter per second. If the speed of the cart is doubled, the inertia of the cart is
- halved
  - doubled
  - quadrupled
  - unchanged
9. Which person has the greatest inertia?
- A 110-kg wrestler resting on a mat
  - A 90-kg man walking at 2 m/s
  - A 70-kg long-distance runner traveling 5 m/s
  - A 50-kg girl sprinting at 10 m/s
10. Which object has the greatest inertia?
- a falling leaf
  - a softball in flight
  - a seated high school student
  - a rising helium-filled toy balloon

## Dynamics-Newton's 1st Law

11. A lab cart is loaded with different masses and moved at various velocities. Which diagram shows the cart-mass system with the greatest inertia?

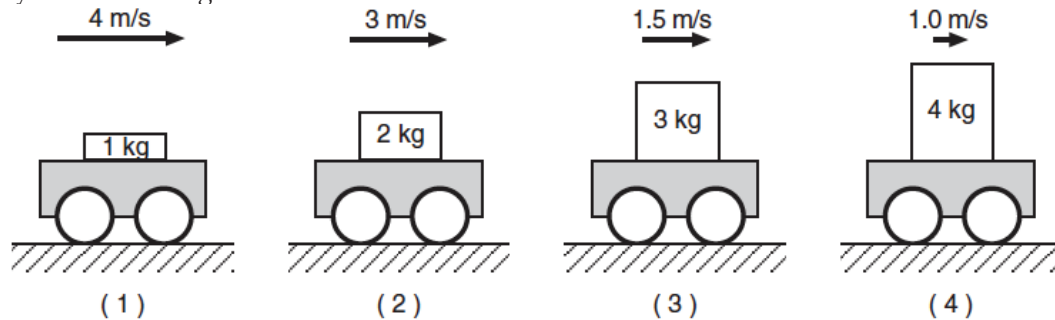

12. Which object has the greatest inertia?

1. A 5-kg object moving at 5 m/s
2. A 10-kg object moving at 3 m/s
3. A 15-kg object moving at 1 m/s
4. A 20-kg object at rest

13. A force of 1 newton is equivalent to 1

1.  $\text{kg}\cdot\text{m}/\text{s}^2$
2.  $\text{kg}\cdot\text{m}/\text{s}$
3.  $\text{kg}\cdot\text{m}^2/\text{s}^2$
4.  $\text{kg}^2\cdot\text{m}^2/\text{s}^2$

14. Which object has the greatest inertia?

1. a 1-kg object moving at 15 m/s
2. a 5-kg object at rest
3. a 10-kg object moving at 2 m/s
4. a 15-kg object at rest

15. Which cart has the greatest inertia?

1. a 1-kg cart traveling at 4 m/s
2. a 2-kg cart traveling at 3 m/s
3. a 3-kg cart traveling at 2 m/s
4. a 4-kg cart traveling at 1 m/s

16. Which object has the greatest inertia?

1. a 15-kg mass traveling at 5 m/s
2. a 10-kg mass traveling at 10 m/s
3. a 10-kg mass traveling at 5 m/s
4. a 5-kg mass traveling at 15 m/s