

alamarin-jet

40
YEARS
of excellence

GO WITH THE FLOW



GREASE / OIL
LUBRICATED
BEARINGS

EASY AND FAST
INSTALLATION
*due to pre-
fabricated
installation
templates*

ADJUSTABLE
IMPELLER
POSITION
extends impeller life

UNIQUE JET
DESIGN *to
maximize space
inside the vessel*

SOLAS
COMPLIANT

Extremely
LIGHT WEIGHT

FLEXIBLE
INSTALLATION
POSITION *with
revolutionary
combi-frame*

DESIGNER,
INSTALLATION &
MAINTENANCE
MANUALS
available

THE ART OF CROSSING SEAS

*Explore the excellence:
Magnificent reasons for choosing
Alamarin-Jet propulsion units.*

You can provide us with the information by filling in an **Application Questionnaire (AQ)** form, which you can request from your Alamarin-Jet representative or directly from sales@alamarinjet.com.

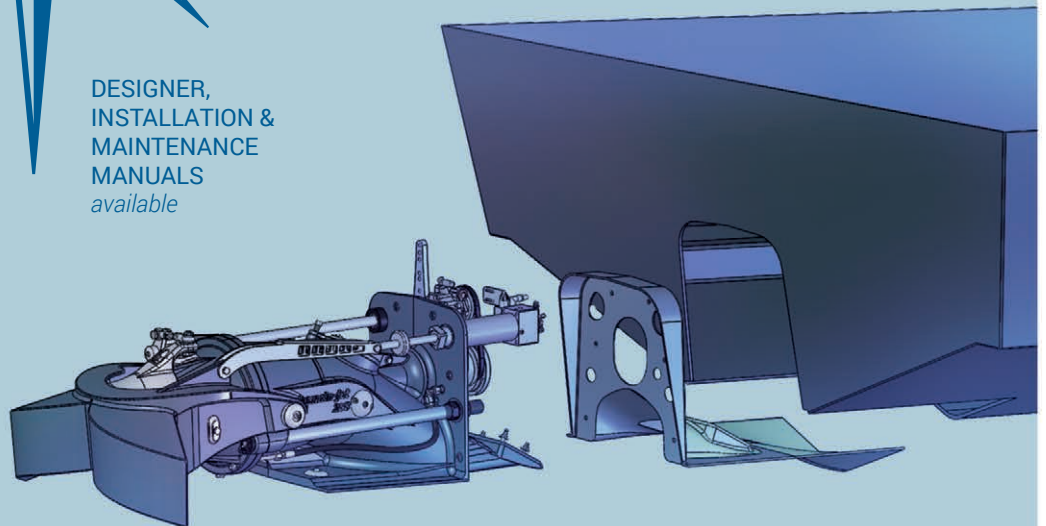









SELECTING THE JET

To ensure the correct choice of jet type for each application, it is essential to start with **optimising components and equipment**. With the main information effecting performance – boat type; hull design, characteristics and material; speed requirement; engine type – we provide a calculation, which helps to select the suitable jets for the vessel. If available, a lines drawing and hull resistance data make predictions even more accurate.

AJ 160











 Mixed flow, single stage	 38 kg (84 lbs)	 Max. 1000 kg (2200 lbs) per single jet, planing boat	 Max. 74 kW (100 mhp)	 Impeller shaft RPM max. 5000 1/min.	 Impeller diameter max. 186 mm (7.3")	 Reverse deflector mechanical or electronic	 Aluminium, stainless steel
--	--	--	--	---	--	--	--

Grease lubricated front and rear bearings.

AJ 180/185











 Mixed flow, single stage	 48 / 50 kg (106 / 110 lbs)	 Max. 1700 kg (3700 lbs) per single jet, planing boat	 Max. 110 kW (150 mhp) / 120 kW (163 mhp)	 Impeller shaft RPM max. 5000 1/min.	 Impeller diameter max. 192 mm (7.6") / 197 mm (7.8")	 Reverse deflector mechanical or electronic	 Aluminium, stainless steel
--	--	--	--	---	--	--	--

Grease lubricated front and rear bearings.

AJ 230











 Mixed flow, single stage	 81 kg (179 lbs)	 Max. 3000 kg (6600 lbs) per single jet, planing boat	 Max. 190 kW (260 mhp)	 Impeller shaft RPM max. 4500 1/min.	 Impeller diameter max. 228 mm (9")	 Reverse deflector hydraulic	 Aluminium, stainless steel
--	---	--	---	---	--	---	--

Optional hydraulic oil cooler. Tube type reverse deflector as standard. Round type and twin installation tube deflector optional.

Grease lubricated front and rear bearings.

AJ 245











 Mixed flow, single stage	 95 kg (209 lbs)	 Max. 3500 kg (7700 lbs) per single jet, planing boat	 Max. 235 kW (320 mhp)	 Impeller shaft RPM max. 4600 1/min.	 Impeller diameter max. 245 mm (9.7")	 Reverse deflector hydraulic	 Aluminium, stainless steel
--	---	--	---	---	--	---	--

Integrated reversing cylinder oil cooler and hydraulic cylinder for steering nozzle as standard. Flexible installation length: short tail or long tail.

High cavitation limits. Oil lubricated front bearing, grease lubricated rear bearing. Automat as option.

AJ 285









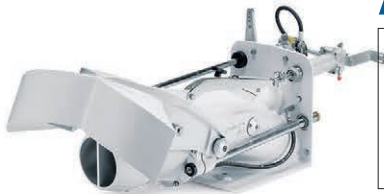

 Mixed flow, single stage	 148 kg (326 lbs)	 Max 5000 kg (11000 lbs) per single jet, planing boat	 Max 370 kW (500 mhp)	 Impeller shaft RPM max 3700 1/min	 Impeller diameter 288 mm (11.3")	 Reverse deflector hydraulic	 Aluminium, stainless steel
--	--	--	--	---	--	---	--

Flexible installation length: Short tail or Long tail. Integrated reversing cylinder oil cooler and hydraulic cylinder for steering nozzle as standard.

High cavitation limits. Oil lubricated front bearing, grease lubricated rear bearing. Automat as option.

AJ 288









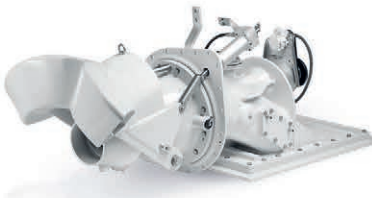

 Mixed flow, single stage	 120 kg (265 lbs)	 Max. 5000 kg (11000 lbs) per single jet, planing boat	 Max. 330 kW (450 mhp)	 Impeller shaft RPM max. 3700 1/min.	 Impeller diameter max. 288 mm (11.3")	 Reverse deflector hydraulic	 Aluminium, stainless steel
--	--	---	---	---	---	---	--

Optional hydraulic oil cooler.

High cavitation limits. Oil lubricated front bearing, grease lubricated rear bearing (automat).

AJ 340



 Mixed flow, single stage	 245 kg (540 lbs)	 Max 7500 kg (16 500 lbs) per single jet, planing boat	 Max. 550 kW (750 mhp)	 Impeller shaft RPM max. 3300 1/min.	 Impeller diameter max. 335 mm (13.2")	 Reverse deflector hydraulic	 Aluminium, stainless steel
--	--	---	---	---	---	---	--

Integrated reversing cylinder oil cooler. Oil lubricated front bearing.