



# Negative Rake Scrapers (NRS)

## Instruction Manual

Proper use, changing and sharpening blades, and NRS compatibility with Taper-Lock Handle System and other SB Tools



# Table of Contents

Effectiveness and When to Use Negative Rake Scraping.....	1	Sharpening Tips, Rules & Info for your NRS.....	5
What Makes a Negative Rake Scraper.....	2	Universal Grinding System.....	7
Negative Rake Scrapers Require a Burr to be Effective.....	3	Safety, Safety, Safety.....	8
		Benefits of the SB Tools Taper-Lock Handle System.....	9



Grinding Wheel Selection.....11

Sharpening Technique.....13

Changing Blades.....17

Why Negative Rake Scrapers  
are Not Aggressive.....19

Sharpening  
your Domed Blade.....21

Sharpening  
your Straight Blade.....22

Sharpening  
your Swept Blade..... 23

Sharpening  
your Skewed Blade.....24

Sharpening  
your Deep Bowl Blade.....25



# Effectiveness and When to Use Negative Rake Scraping

What woodturners now refer to as Negative Rake Scraping has been used since the 1500s for turning ivory and dense exotics. Stuart Batty established the rules on how, when and where to use this technique, as well as named it “Negative Rake Scraping” over a decade ago to distinguish it from Conventional Scraping.

Negative Rake Scraping is a neutral technique. It neither draws the wood in like a Conventional Scraper, nor pushes it away like a Gouge, making Negative Rake Scraper (NRS) among the easiest of all woodturning tools to use.

Negative Rake Scraping is a very effective technique on thin walled pieces and broken surfaces, such as natural edge pieces and square bowls.

Negative Rake Scraping is the only technique that can work with every grain orientation and density while never becoming aggressive. Though it can be used on softwoods, it is ideally suited to medium density temperate woods through to the densest of exotics. It is also the most effective technique for use on acrylics, plastics and acrylic/resin impregnated woods because it will not grab at them.

A Negative Rake Scraper can be used either side up. When cutting at the very center of a box or bowl use caution; do not let the edge cut past center or the blade will jump on the tool rest.

Negative Rake Scraping will not remove wood as quickly as a Conventional Scraper; however, it’s a far more effective finishing technique due to the ease of control and its ability to give an unmatched finish when used correctly with a fresh burr on the edge.

Negative Rake Scrapers can have large edge areas in contact with the wood and remain under control, which is why we make an array of larger blade sizes of up to 3” wide. At 3” wide, a Conventional Scraper would be uncontrollable.

**NOTE:** Carbide blades are NOT effective for Negative Rake Scraping due to the fact that they cannot create a burr.

Negative Rake Scraping, when done correctly, will improve your shapes and dramatically reduce your sanding time.

**Don’t forget: the edge of the blade MUST have a burr present to be effective.**



# What Makes a Negative Rake Scraper?

For a scraper to be considered a Negative Rake Scraper it must have a secondary bevel on top of the blade. Lifting the handle of a Conventional Scraper so that the blades points down hill does not make it a Negative Rake Scraper.



An NRS can be use even with the handle slightly lower than the blade, however, it must **NOT** be so low that the top bevel is pointing up hill, doing so on end grain would make it aggressive.

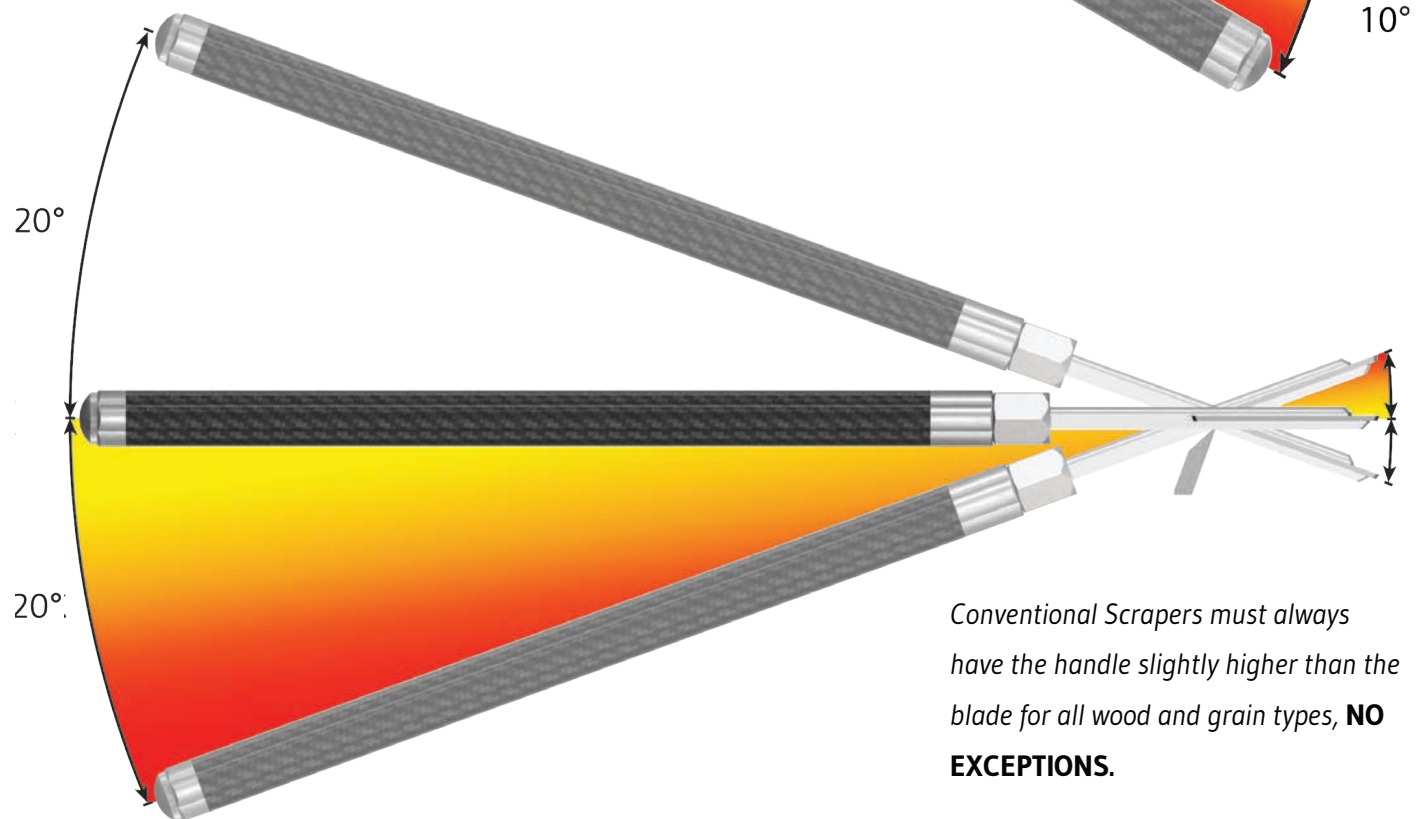
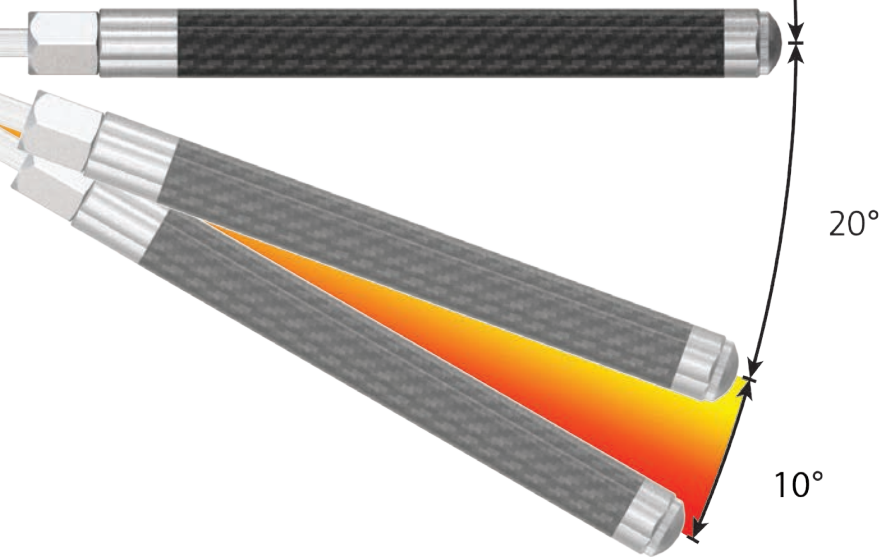

Conventional Scrapers must always have the handle slightly higher than the blade for all wood and grain types, **NO EXCEPTIONS.**



# Negative Rake Scraping Requires a Burr to be Effective

It is the burr on the top edge of the blade that does all the work when Negative Rake Scraping. If the burr is worn down it must be resharpened to create a new burr or the tool will require more pressure to work and, as it dulls, begin to damage the wood fibers.

With a fresh burr the NRS will require just light pressure to remove wood. Resharpening the blade often and early will give exceptional results.

Your NRS can be used either side up. For Negative Rake Scraping to be effective, a burr must be present on the side of the blade facing up. If you can't feel the burr with your finger when you draw it away from the edge of the blade, you do not have a burr. This is your signal that it is time to resharpen the blade.

It is important to check by feeling for the burr by drawing your finger backwards and away from the edge so as not to cut yourself.

Resharpening is best performed on a bench grinder with 8" diameter wheels. All wheels will produce a burr on the CPM 10V® blade, including CBN, SG and Aluminum Oxide. As Negative Rake Scraping relies solely on a burr being present, we chose to create our blades using CPM® 10V, which boasts 5x the life on M2 and has a burr life of approximately one minute of optimum performance per ½" width. Wider blades, assuming you're using the entire edge area, will give you a longer cutting life. Though this may seem a short life for any blade, you will see that the finish and ease of shaping make this unique technique extremely effective.

With a new burr on the edge, your NRS can easily smooth out long surfaces, refine sharp details on almost any piece and create an exceptional finish on almost any wood type, density or grain.

To create the burr ensure you set the platform angle on your grinder to 25° (you can go as low as 20° but 25° is ideal). The SB Angle Gauges are designed to aid in the setup.

**WARNING: Never set a Conventional Scraper to this angle, as it would be uncontrollable and dangerous.**



**Setting the Platform with  
the SB Angle Gauge**

# Sharpening Tips, Rules & Info for your NRS

All SB Tools Negative Rake Scrapers come with an included edge angle of  $50^\circ$  (bevel angles of  $25^\circ$ ) and a burr on one side, indicated by the sticker.

The sticker indicates which side the burr is on for first use; remove the protective rubber coating before use and before resharpening. The sticker should face up for first use and for first resharpen. However, if the scraper is used on the other side for any reason then the sticker will no longer be necessary and should be removed.

**NOTE:** The lower the included angle on a Negative Rake Scraper the larger the burr that will be created by the grinding wheel and the longer it will last. The very lowest included angle should not be less than  $40^\circ$ ; the maximum included angle should not be greater than  $70^\circ$ . Going above  $70^\circ$  will create a burr simply too small with a very short life. A  $90^\circ$  or greater included angle will not create a burr and render the edge completely ineffective.

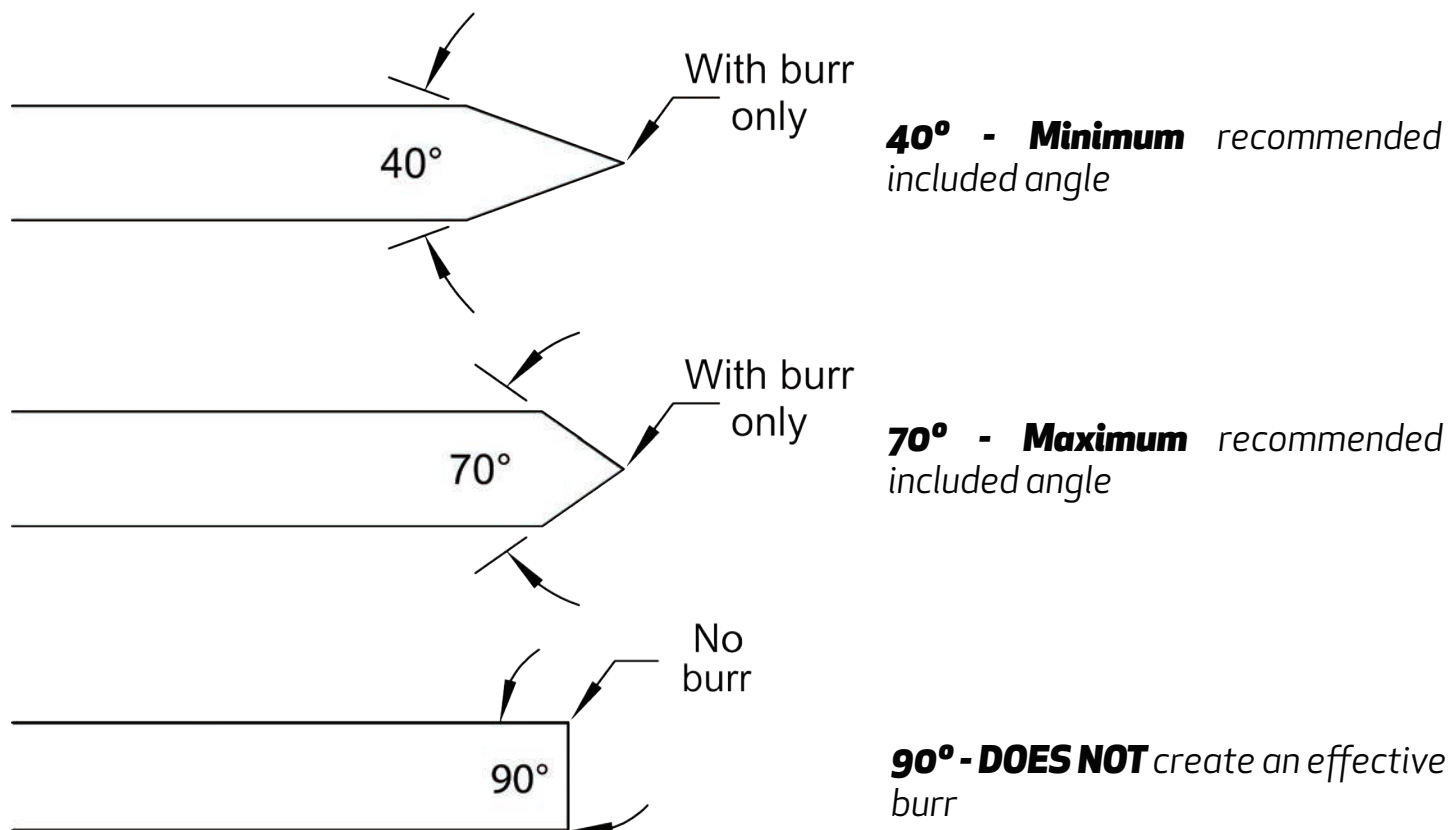



## Sharpening a NRS domed blade.



To set the included angle we recommend using SB Tools Angle Gauge One with the 25° setting; this is the same angle the blade has been ground at from the factory. Our Angle Gauge works on wheels from 5" to 10" diameter and is 100% accurate at 8" diameter wheels, and within one degree between 6" and 10" diameter wheels.

Note that because NRS are double beveled blades they have two 25° bevels, making an included angle of 50°.

**NEVER** sharpen a **Conventional Scraper** at this angle, it would be completely uncontrollable and extremely dangerous. It would climb in to the wood. The very lowest angle for a Conventional Scraper should not be less than 60° for softwoods, 70° for temperate hardwoods and 80° for dense woods. See the free PDF download at [woodturning.org](http://woodturning.org) for more details on Conventional Scraping techniques and sharpening. (Release date April 2013)

**NOTE:** Our blades were ground on an 8" diameter CBN wheel (80-Grit). These wheels do not wear down like conventional wheels. If your wheel is a different diameter, it may take a few repeated grinding motions to create the burr the first time.

# The Universal Grinding System (UGS)

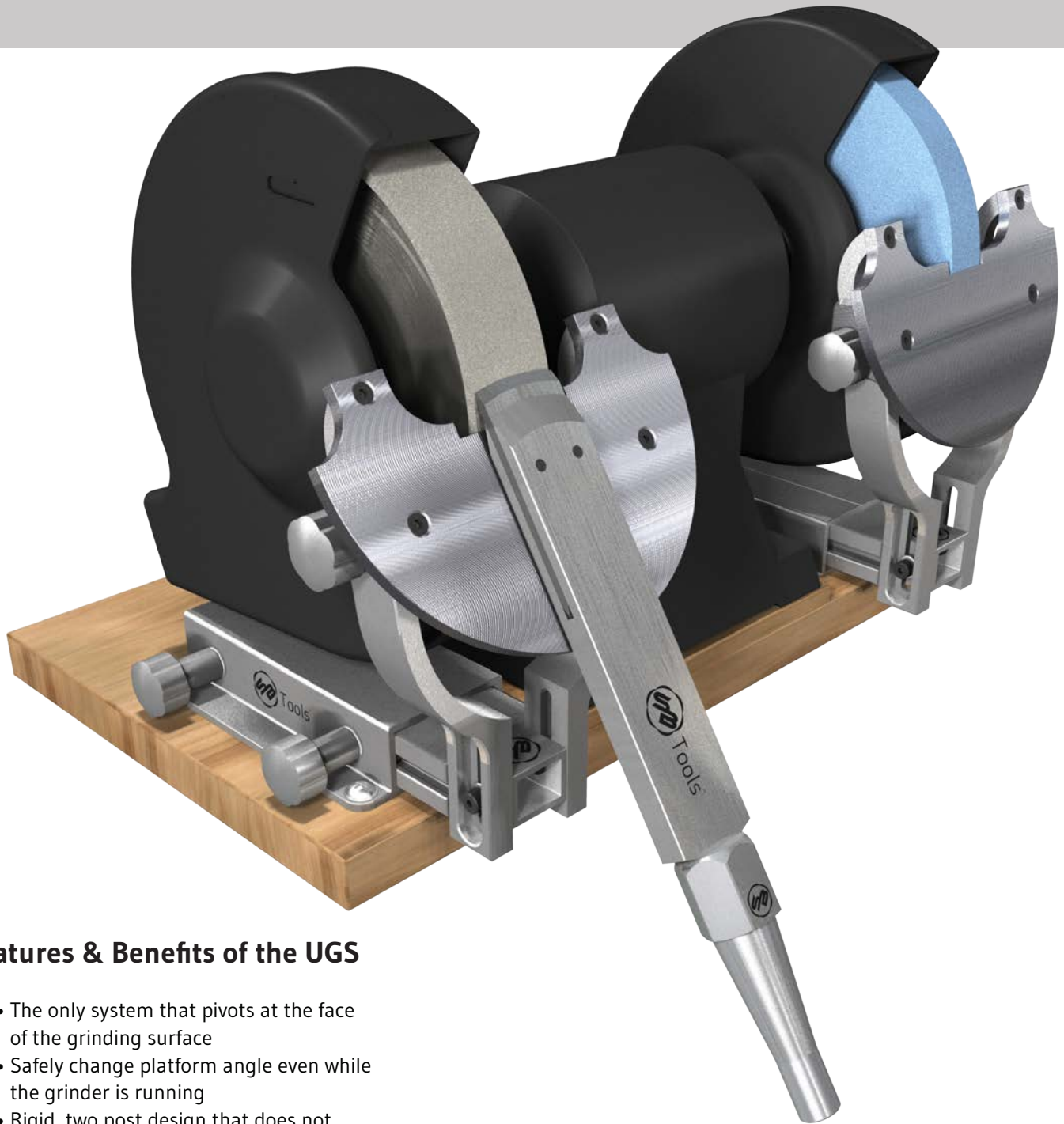

## Features & Benefits of the UGS

- The only system that pivots at the face of the grinding surface
- Safely change platform angle even while the grinder is running
- Rigid, two post design that does not interfere with the casing of the wheel
- Works with all bench grinders with 5" – 10" diameter wheels and many belt grinders
- Option of four different platform shapes
- Adjustable height
- Create angles from 10° – 95°
- Unique pressure plate systems only require finger tightening for secure locking
- Option of the more rigid and secure SB Mounting Base or adapter for the Oneway base

It is **ESSENTIAL** to grind your NRS on a rigid platform. The SB Tools Universal Grinding System offers various shaped and sized platforms that work seamlessly with all grinders, plus offer unmatched rigidity and vibration dampening. Grinding without a platform, or failing to place the blade flatly on the platform, will produce an inconsistent edge or no burr at all.

# Safety, Safety, Safety

Always wear safety glasses and a dust mask while grinding. Keep any loose clothing away from the grinding wheel.

If you are using a regular SG, Aluminum Oxide or any other stone type wheel, ensure it is free from damage. If it is chipped or cracked it **MUST** be replaced immediately. Even slightly damaged wheels can explode.

CBN wheels do not need to be dressed and have never been known to explode. However, the sparks thrown off while grinding are potentially dangerous if the safety guards from around the wheel are removed.

## Wheel to Platform Distance

It is essential when grinding to ensure that there is a close, safe distance between the front of the platform and the wheel. The greater the gap the greater the risk of injury. When the gap is large the wheel will have a tendency to pull the metal being ground into the gap. The gap should never be greater than  $\frac{1}{4}$ " and a  $\frac{1}{16}$ " is the ideal distance. Our Universal Grinding System (UGS) allows the gap to remain at  $\frac{1}{16}$ " at all angles. Unlike other platform systems, once set at the correct distance and height, our platform cannot crash in to the wheel at any angle even if moved while the grinder is running. **NEVER** move other manufactures' platforms while the wheel is spinning.



# Benefits of Using SB Tools Taper-Lock Handle System

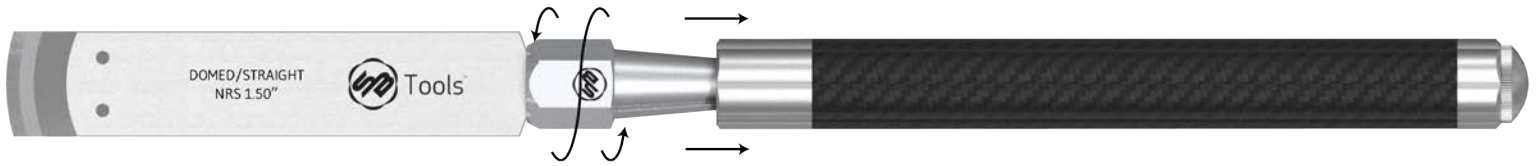

Our Taper-Lock Handle System has been designed to enhance the turning experience. The use of multi composites, including carbon fiber, reduces vibration and weight in the turner's hand. The taper lock bolster on every SB Tools blade is made from vibration dampening grey iron and is the fastest, securest locking system of any modular handle. The NRS  $\frac{1}{2}$ " thick ( $\frac{5}{8}$ " for Deep Bowl version) substrate and iron bolster puts the vast majority of the tool weight directly on to the tool rest where it is needed, and combined with our lightweight composite handle, reduces the weight in turners hand. Our choice of ten handle lengths from 6" to 48" enables the turner to select the appropriate handle for the cut being performed.

**Adjustable Parting Tool 5:1**

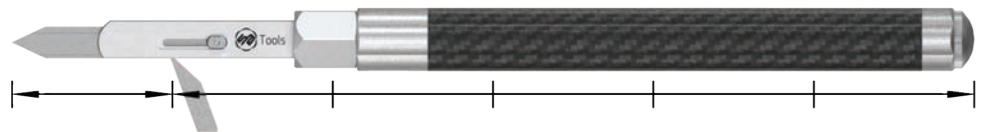

**Negative Rake Scraper 3:1**

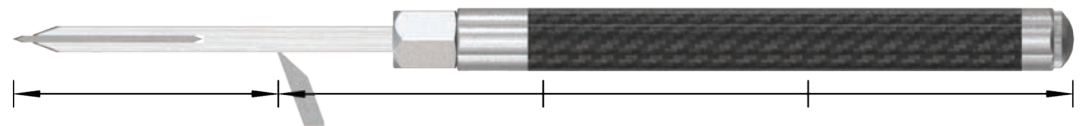

**Bowl Gouge 5:1**

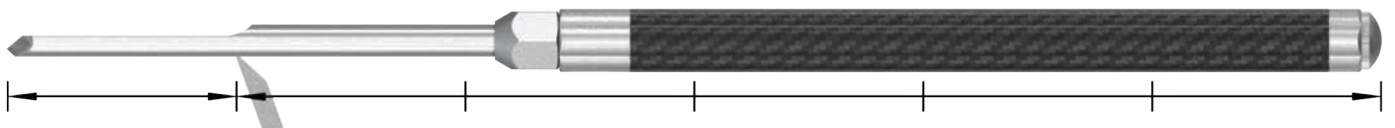

**Conventional Scraper 7:1**

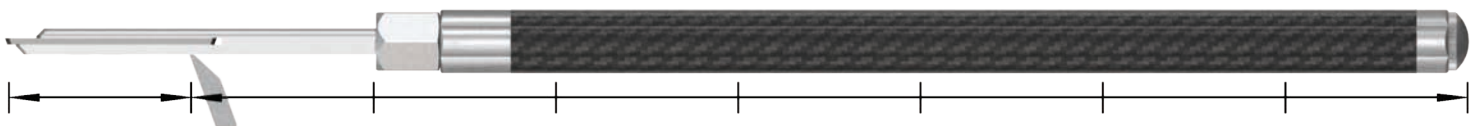





## Handle Length

Negative Rake Scraping requires the lowest overhang ratio of any type of woodturning tool on a lathe: 3:1. This means that for every one inch of overhang the blade has over the tool rest you will need 3 times the overhang comprised of either the handle or a combination of handle and remaining blade length on the your side of the tool rest. For example, if you are cutting four inches over the tool rest you must have at least 12" of overhang using some combination of handle and blade to remain in safe control of the tool.

## Changing Handles

It takes only a few seconds to remove the handle and no allen keys are required. The bench wrench can be used to more tightly lock a blade into a handle, but a simple wrist tightening is typically all that's required for Negative Rake Scraping.

## Sharpening Tips

Removing the handle will make resharpening your blade easier. Without a handle in your way you can stand closer to the grinder, giving you better control, especially for the Swept Back blades. It also

reduces the chance of the turner lifting or dropping the handle while sharpening.

Lifting or dropping the handle will create a defective edge.

(See our free Negative Rake Scraping video for techniques, and trouble-shooting at woodturning.org. Release date April 2013)

It is essential to keep the scraper flat on the platform while grinding. Lifting or dropping it will not give you a repeatable edge the next time you grind.



# Grinding Wheel Selection

We recommend an 80-grit CBN (Cubic Boron Nitride) wheel to resharpen and create a new burr. Though more expensive than SG (Seeded Gel) and Aluminum Oxide wheels, CBN wheels do not wear down and tend to grind slightly cooler. The CBN also has the ability to cut through the hard vanadium carbides in CPM-10V® creating a better edge.

Though both SG and Aluminum Oxide wheels create a satisfactory burr, the SG will grind cooler and clog less than the Aluminum Oxide wheel.

**NOTE:** If your wheel wears down, you will need to reset the angle on the platform to maintain a constant 50° included angle (25° bevel angle).

Our NRS' are ground at a low included angle of 50°. It is possible to overheat the edge when you are creating a new burr. As long as you are creating a satisfactory burr this is not necessarily a problem. Slight discoloration at the edge of the blade simply means you heated it up enough to begin oxidation. You have not removed the temper from the CPM-10V®. There is no need to waste steel regrinding the discoloration away as long as you have a burr.

Dipping your blade in water during grinding will help to keep it cool and prevent overheating. It will not create micro cracks, you simply cannot get the blade hot enough to thermally shock this steel on a bench grinder and you will not remove the temper in CPM-10V®.

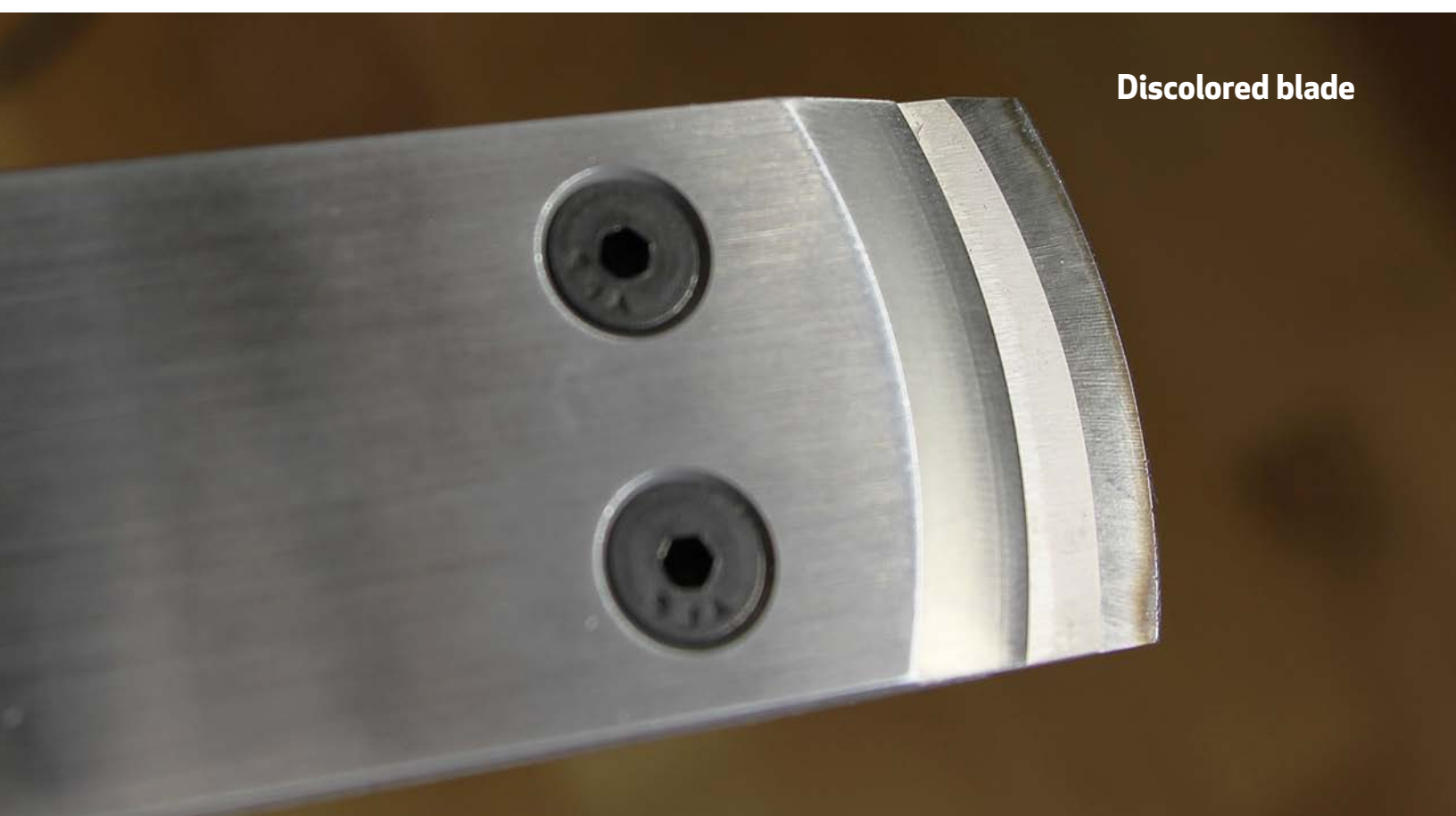

**Discolored blade**

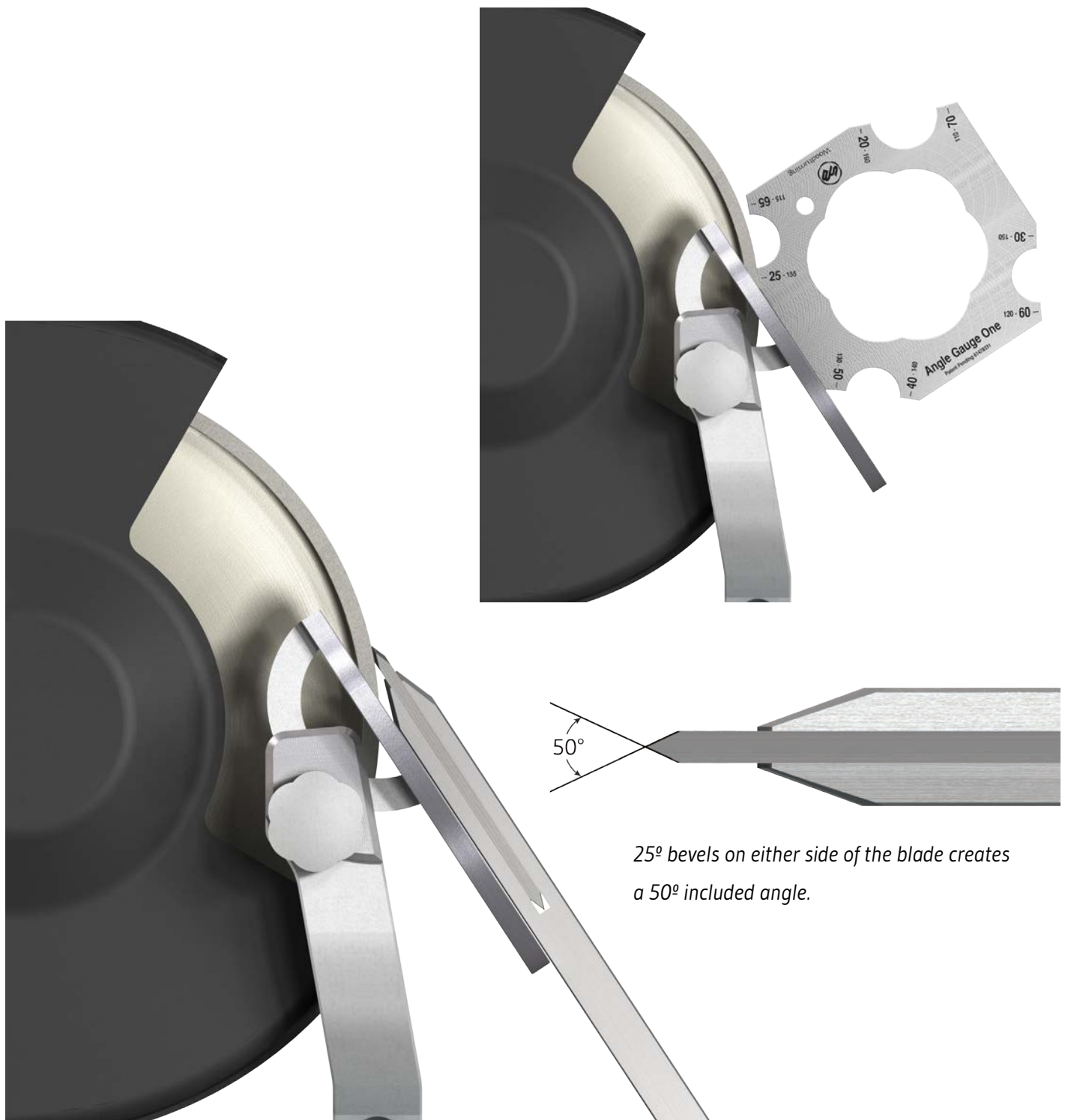

**NOTE:** The coarser the grinding wheel the larger the burr that will be created.  
Larger burrs last longer, but they also wear the blade down more quickly.

# Sharpening Technique: Wheel Maintenance

## SG & Aluminum Oxide Wheels

Because these types of wheels wear down and groove through repeated use, we recommended you dress the wheel prior to using it for recreating a burr on any type of scraper.

Do not feel the edge of the blade, it is extremely sharp, rather, draw your finger back away from the edge to feel for the burr. If you can't feel a burr then you do not have one. You should also be able to feel a consistent burr across the entire edge of your tool. If you cannot, you have missed a section and this part of the blade will not be effective.

Resharpening is best done using a rigid platform system. Do not try to resharpen "freehand"; doing so will produce an inconsistent and inferior burr.





# Sharpening Technique: Common Mistakes

## Common mistakes when grinding blades

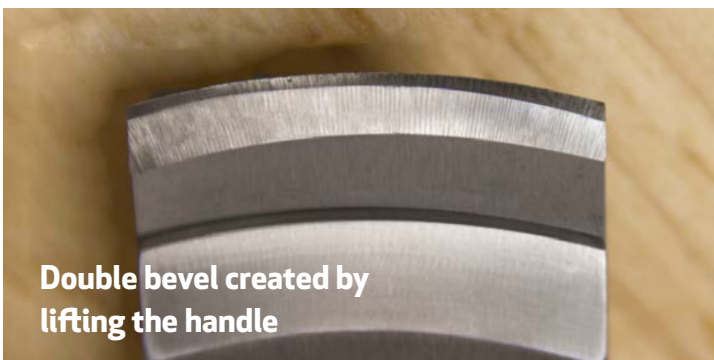

The most common mistakes when grinding are to lift the **back** of the blade off the platform (Photo 1) or to drop the back of the blade (Photo 2). Either of these errors will cause problems with creating a burr, which is essential in order for your NRS to work.

# Sharpening Technique: Correct Positioning

## Ideal Positioning

Place tool flat on grinding platform and keep your hand close to the platform at a safe distance away from wheel.

**TIP:** Remove your handle (if you can) before sharpening.







**Removing the handle reduces the chance of your doing this.** However, if you don't want to remove the handle, then ensure you hold the tool as close to the platform as possible and don't actually hold the handle when grinding. Your other hand should help to position the blade flat on the platform and add a small amount of pressure.

If you do lift the blade while grinding you will still create a burr but will have created a second bevel angle at the front of the blade (see Photo 1). However, the next time you grind you will not get an immediate burr because the bevel angle has now been changed to a much lower angle. It will therefore take a few regrinds to establish a new burr.

If you drop the blade while grinding (see Photo 2), you are only grinding the bevel at the back and are not actually creating a burr. This does not damage the blade and when you check for the burr by drawing your finger over and away from the edge you will not be able to feel a burr. Simply place the blade back on the platform and ensure you do have it flat and then resharpen.



**NOTE:** Never allow a Negative Rake Scraper tool to function as a Conventional Scraper by sharpening it so many times that the negative top bevel angle has been ground away. Doing so will make your blade uncontrollable.

Domed/Straight NRS can be flipped each time they are resharpened to avoid this. **Swept Back** and **Skewed NRS**, if used just on one side, will eventually lose their top bevel angles from continuous sharpening. Once the bevel becomes short you must re-grind a top bevel on the blade.

Repetitive grinding of one side of the blade will turn the 50° included angle to a 25° included angle. **This turns the Negative Rake Scraper into a Conventional Scraper making the blade aggressive and uncontrollable.**

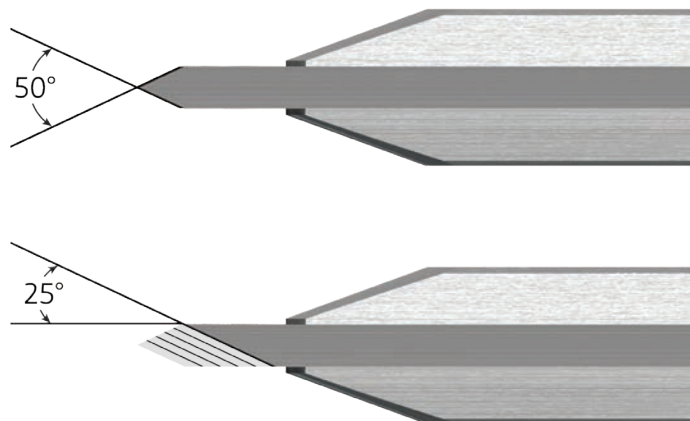

*NRS blade "becoming" a Conventional Scraper.*

# Changing Blades

## Moving Replaceable Blade Forward or Spinning it to Use other Edge

Our blades are precision machine fitted into their substrates, and the blade maybe tight when needing to move it. Therefore, be very careful not to cut yourself when pulling your blade forward. We suggest using a vise or grips to pinch the front of the blade to pull it forward rather than trying to reposition your blade by hand. A vice is also a safe easy way to grip the blade to pull it forward.

To spin the blade for use on its other side, simply remove the set screws. We recommend using a piece of scrap wood to aid in this process. Again, maneuvering your blade by hand can be dangerous.



After removing the set screws simply push the corner edge of the blade into the scrap wood or plastic to keep the edge away from your hands and push down on the substrate to pivot the blade round. Continue to use the scrape wood to pivot the blade all the way round and push it back into

the substrate. The second edge on the blade is NOT supplied pre-sharpened for safety reasons. You will need to grind the edge until you produce a fresh burr, initially this might take a few minutes



### Do Not Overtighten The Fastening Screws

When tightening the blade in place initially, or after spinning it around to use its second edge, you only need to pitch up both setscrews.

It is **ESSENTIAL** to keep both screws in use at all times. **NEVER** remove one screw to get more life out of the blade or to spin the blade off center. Doing so can be dangerous. The safety and efficiency of product depends on the use of both set screws.



# Why Negative Rake Scrapers are Not Aggressive

## It's all in the Geometry

Negative Rake Scrapers have a different geometry than Conventional Scrapers. This geometry makes Negative Rake Scrapers neutral (NRS) and the Conventional Scrapers aggressive.

A Negative Rake Scapers burr is on a different plane than the base of the blade due to the secondary bevel angle. In other words, the burr is not in parallel to the length of the tool. This makes the blade inert and prevents the edge from being attracted to the wood surface.

A Conventional Scraper cutting edge is on the same plane as the base of the blade. In other words, the top surface of the edge is in line and running parallel to the length of the tool. By having both the support surface and the edge on the same plane, an attraction is created when presented to the wood. This attraction can make the blade aggressive or even catch. A self-feeding catch in this regard is a leverage catch – caused by insufficient leverage on the side of the turner. Longer handles can help reduce this but only to a point. Conventional scrapers need to be ground at different angles for different wood densities and grain orientation.

We will be posting a full article on Conventional Scraping for free download at [woodturning.org](http://woodturning.org) in April with all the rules. However, there is information contained within our Product Catalog that will also help.

## Conventional Scraping

Conventional Scraping can be an aggressive technique and requires three different angles for the three main wood densities and grain types for which this technique is most commonly used.

To maintain control, Conventional Scraping requires the greatest amount of leverage of all woodturning tools: a minimum overhang ratio of 7:1.

## Negative Rake Scrapers

Negative Rake Scraping is by comparison, almost never an aggressive technique and requires the lowest amount of leverage and overhang ratio: typically 3:1.

Conventional Scrapers are by nature a self-feeding tool and Negative Rake Scrapers are neutral tool that neither draw themselves in or push the wood away.

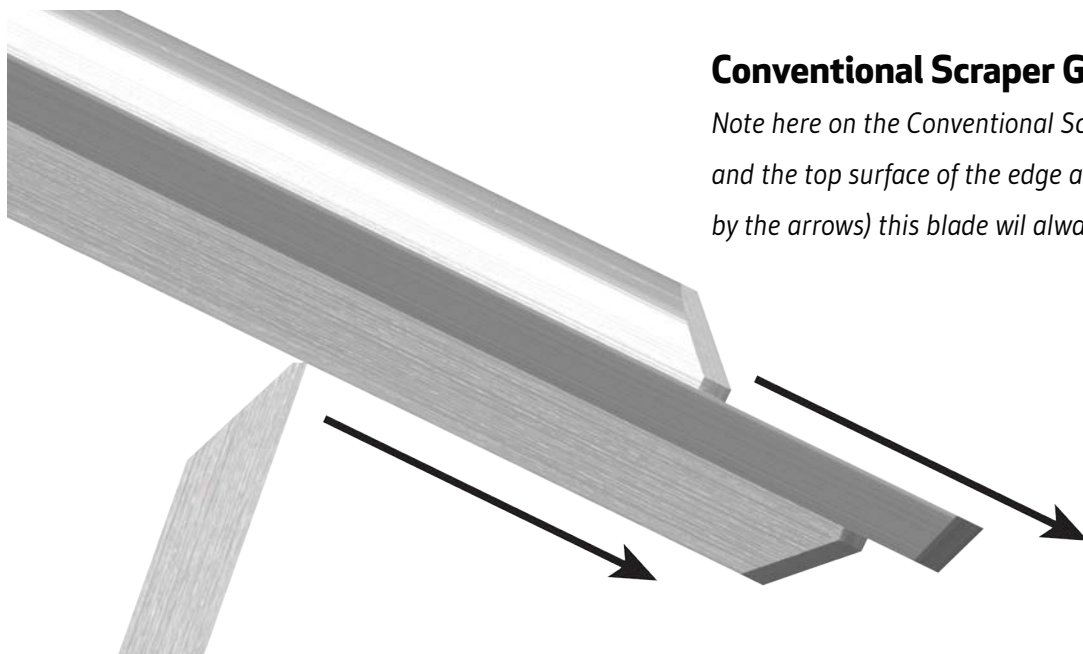

### **Conventional Scraper Geometry**

*Note here on the Conventional Scraper that the base of the tool and the top surface of the edge are on the same plane (indicated by the arrows) this blade will always have a tendency to self-feed*

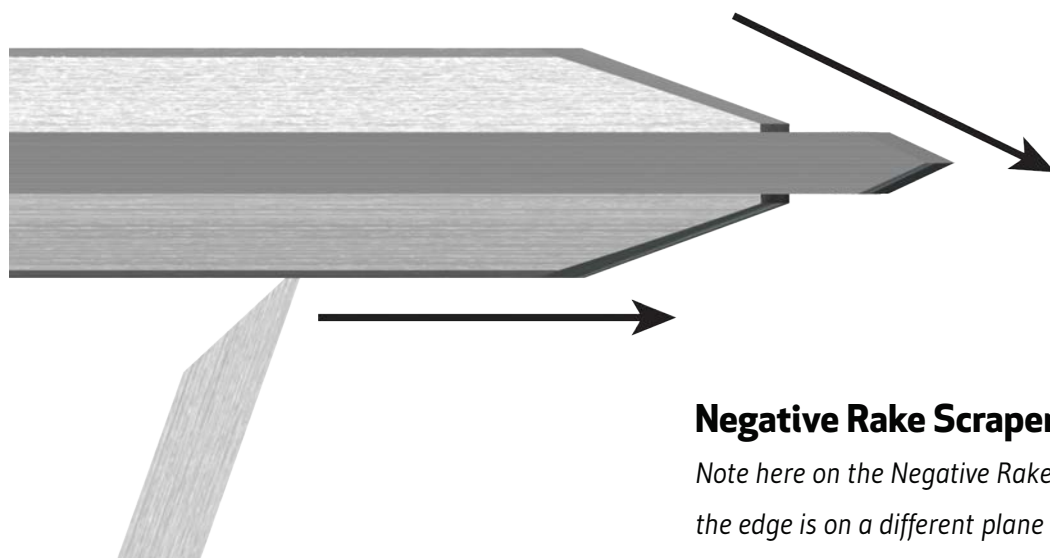

### **Negative Rake Scraper Geometry**

*Note here on the Negative Rake Scraper that the top surface of the edge is on a different plane to the base of the tool. It is the difference in the two surface angles that makes this tool neutral and never aggressive.*



# Sharpening Your Domed NRS Blades

Domed blade NRS are ideal for shallow concave shapes. These blades work on all wood and grain types.

These blades are domed one side and straight on the other. To grind the domed shape you will need to pivot the tool in an arc on the grinding wheel to keep the domed shape. If you need to have less or more of an arc you may need to grind both the top and bottom bevels to the new desired shape.

It is recommended to flip this type of blade over each time you sharpen. This will help increase the blade life and always keep a second bevel.



# Sharpening Your Straight NRS Blades

Straight blade NRS are ideal for producing straight surface cuts and convex shapes like the out side of bowls. These blades work on all wood and grain types.

These blades are straight one side and domed the other. Note that we supply these straight blades with a very slight convex curve. This is to aid in long traversing cuts and helps to prevent the very corner of the edge from scoring the work.

When regrinding the edge, if you wish to keep the very slight convex shape, arc the blade very slightly when moving the blade across the wheel. If you desire the edge to be straight and remove the slight convex shape, then slide the blade across the wheel with no arc.

It is recommended to flip this type of blade over each time you sharpen. This will help increase the blade life and always keep a second bevel.



# Sharpening Your Swept Back NRS Blades

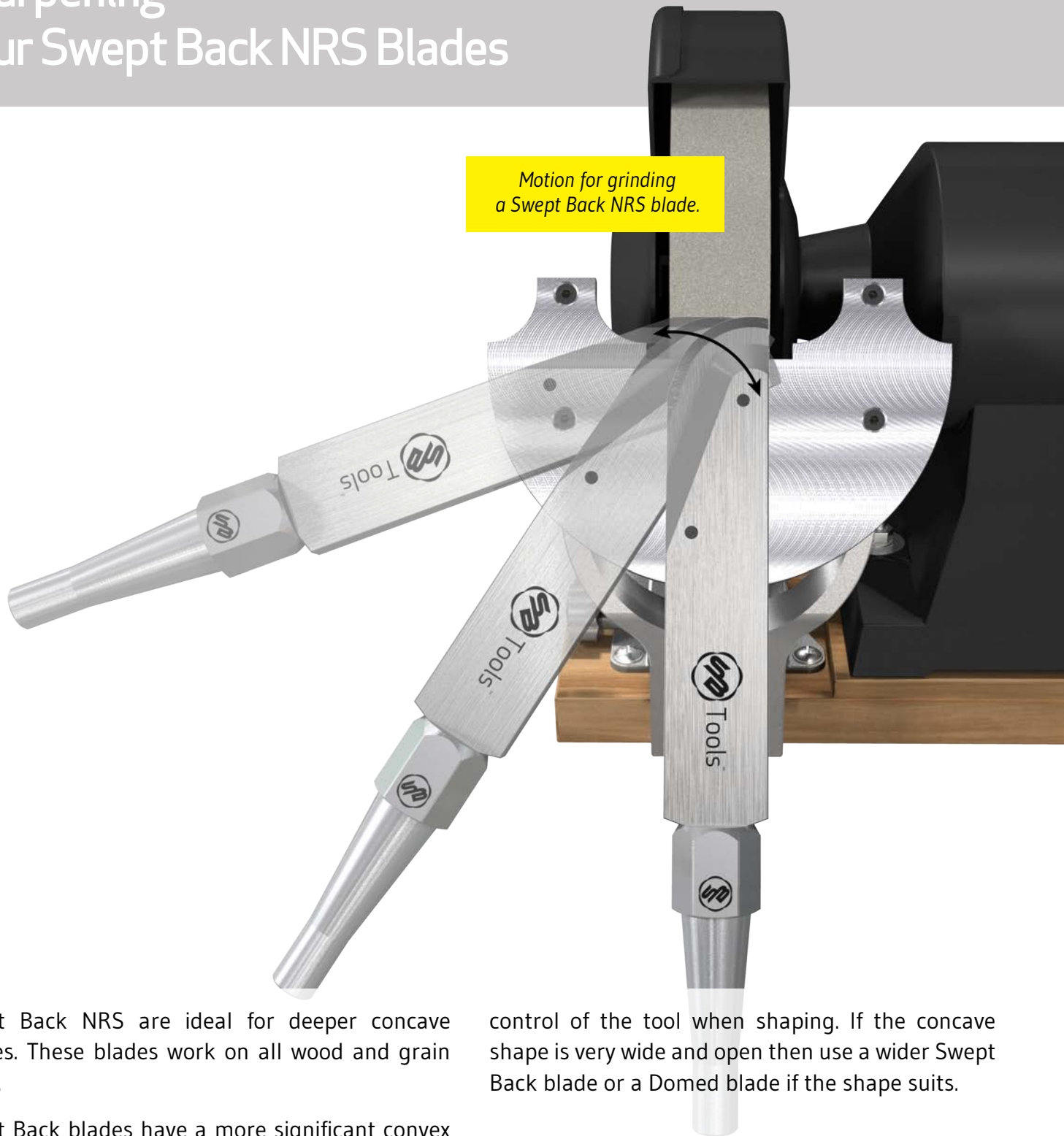

Swept Back NRS are ideal for deeper concave shapes. These blades work on all wood and grain types.

Swept Back blades have a more significant convex curve than the Domed blades. The blade will need to be arced across the wheel following the original shape to produce a new burr. If you need a tighter concave shape than the blade width, you will need a narrow NRS tool. Using a Swept Back NRS closer to the actual shape will help with the finish and

control of the tool when shaping. If the concave shape is very wide and open then use a wider Swept Back blade or a Domed blade if the shape suits.

Swept Back blades tend to be used much more for left side concave surfaces and come ground from the factory to suit this purpose. If you require to use the Swept Back NRS the other way up for right side convex shapes, you will need to grind the factory set flat top bevel a few times to ensure you have a burr on the opposite side of the blade.

# Sharpening Your Skewed NRS Blades

Skewed blade NRS are ideal for convex shapes and are able to reach into areas or shapes that straight blades cannot. They are also suitable to creating both dovetail tenons and recesses for chuck mounting. These blades work on all wood and grain types.

These blades are supplied with a slight convex on the skewed edge. This aids with long traversing cuts and helps prevent the corner edge from scoring the surface. To create the same original slight convex skewed shape, arc the blade slightly as you pass it over the wheel. If you require a straight skewed edge with no convex, then traverse the blade across the wheel with no arc.

If you use this blade one-way up for a significant amount of regrinds, it is essential to ensure that you always have the secondary bevel on the top surface. Never allow this bevel to be ground away. If the secondary bevel is be ground close to disappearing, then grind this bevel a number of times to ensure it remains present. Alternatively if you have two Skewed Negative Rake Scraper, use one for left skew cuts and one for right and swop them out periodically. This will give you maximum blade life and avoid the necessity to grind the secondary bevel back.





# Sharpening Your Deep Bowl NRS Blades

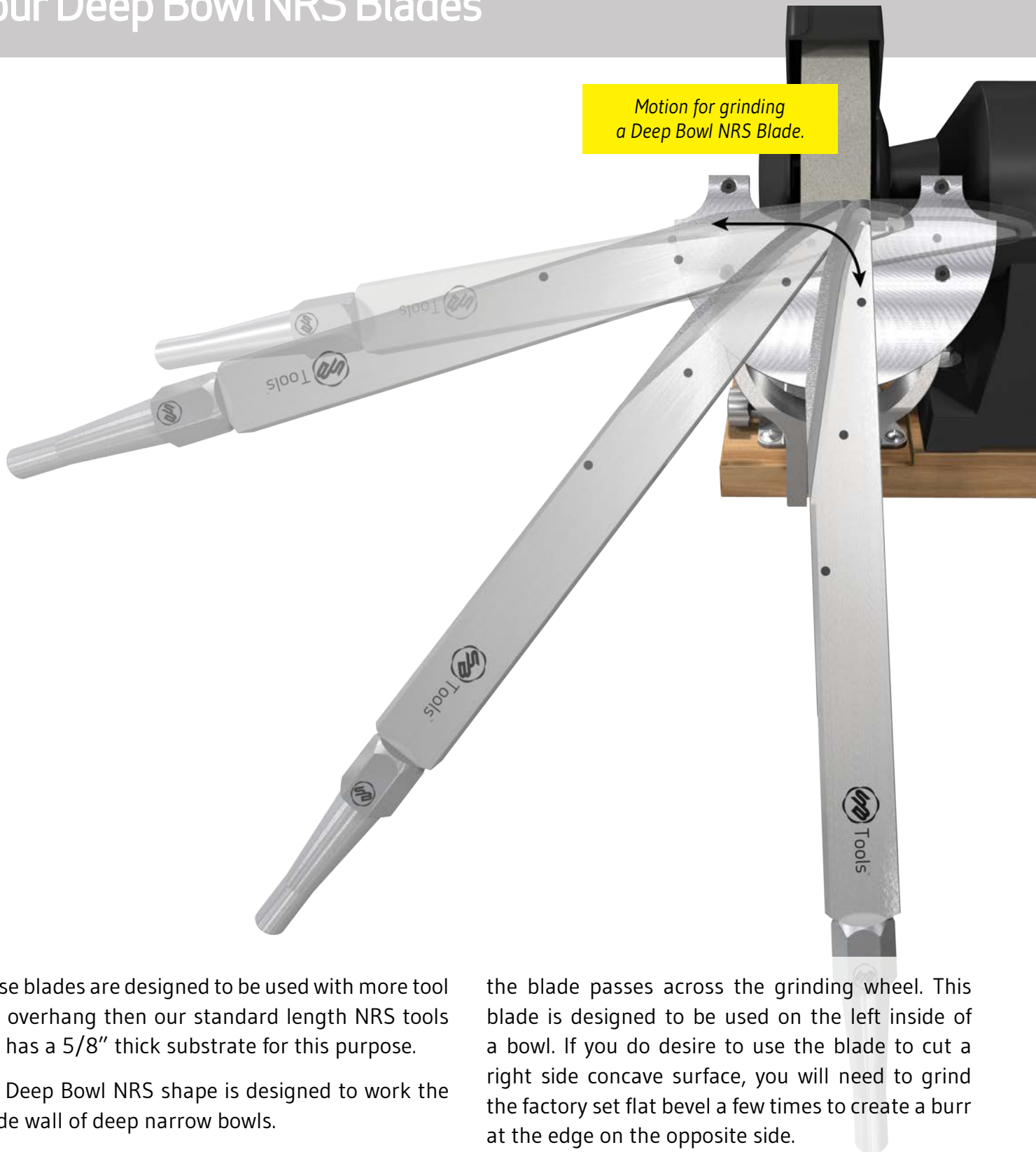

These blades are designed to be used with more tool rest overhang than our standard length NRS tools and has a 5/8" thick substrate for this purpose.

The Deep Bowl NRS shape is designed to work the inside wall of deep narrow bowls.

To regrind follow the tight arc at the front of the blade being careful to blend in to the longer more open convex shape of the blade down the side as

the blade passes across the grinding wheel. This blade is designed to be used on the left inside of a bowl. If you do desire to use the blade to cut a right side concave surface, you will need to grind the factory set flat bevel a few times to create a burr at the edge on the opposite side.





# IMPORTANT

IT IS ESSENTIAL THAT THE TOP BEVEL OF YOUR NRS BLADE IS NEVER GROUND COMPLETELY AWAY. DOING SO WOULD EFFECTIVELY “TURN IT INTO” A VERY AGGRESSIVE CONVENTIONAL SCRAPER WITH A 25° INCLUDED ANGLE.

AS THE TOP BEVEL OF YOUR NRS WEARS DOWN, REGRIND IT. FLIP YOUR BLADE PERIODICALLY AND GRIND AS NEEDED TO ENSURE THAT THERE ARE ALWAYS TWO WORKING BEVELS.

**NOTE:** Whichever side is facing up when ground is the same side that the burr will be created on. This side should face up when cutting.

**WARNING:** Woodturning can be dangerous. Improper use of tools, equipment, products or materials as well as not following recommended safety guidelines can result in SERIOUS INJURY or DEATH.

Respiratory problems and other health conditions can build over years. YOU are responsible to make sure you are properly educated in all aspects of woodturning and to follow safety guidelines and manufacturers recommendations regarding the proper use of product.

Any illustration or description of techniques and safety guidelines described in this publication cannot be relied upon to guarantee protection against personal injury.

If you have questions regarding proper lathe operation, tool use or safety guidelines, please consult an expert. Safety is YOUR responsibility.

Take appropriate cautions when you turn. As an additional resource, please refer to the American Association of Woodturners Resource page at



Please visit [woodturning.org](http://woodturning.org) for more information about SB Tools.

A FREE Stuart Batty HD video about Negative Rake Scraping will soon be available our website Summer 2013.