

Distributed by:

**WATER CONTROLS
& PUMP SYSTEMS**

808-876-0132

www.watercontrols.com

WATERTRONICS™
A LINDSAY COMPANY

VERTICAL TURBINE QUICKSHIP (VTQ)

QUICKSHIP



2 PUMP SKID



2 PUMP SKID WITH WYE STRAINER



2 PUMP SKID WITH FILTER

Same vertical turbine quality to you faster in a new resized package

Ideal for pumping from reservoirs, rivers and wells, the Vertical Turbine (VT) system from Watertronics is a single source solution that can meet pressure and flow requirements regardless of water lift or depth.

With over 30 years of experience, Watertronics has identified our most popular Vertical Turbine (VT) station designs and packaged them into a new product line called the Vertical Turbine Quickship (VTQ). The VTQ features the same high quality design, controls and functionality customers expect in our larger VT stations, but offers faster delivery times and a smaller station footprint to accommodate existing pump houses. Flexible designs allow for 18 different standard configurations to suit almost any station layout need.

Your VTQ station arrives pre-tested specifically to your performance requirements, ensuring a quick installation and trouble-free start-up.

SPECIFICATIONS

- Flows up to 300-1800 GPM
- Motor range: 20 to 75 HP
- Voltage options: 460v/3 phase/60HZ
- Pressures from 80-130 PSI
- 5 week delivery time*
- 18 standard mechanical configurations
- 2 year limited warranty on station including labor
- FCC Class A, B and C compliant

*5 week delivery available for 48 US contiguous states.

CONTROLS

- VFD with advanced PLC logic
- 7 1/2 in. color touch screen
- Full size illuminated door switches
- Surge protection
- Pond level controls with graphic readout

STANDARD FEATURES

- Motor – VHS premium efficient inverter duty with winding heaters and 3 year warranty
- Base – 80 x 80, 3/8 in. formed steel construction, no welded seams
- High efficiency vertical turbine pumps with stainless steel impellers
- Discharge head – ductile iron construction with heavy-duty stuffing box
- Sustain pump – 3HP submersible with check valve
- Pressure relief valve – heavy-duty Cla-Val brand
- Heat exchanger – air to water style



Pump Service Network (PSN) provides nationwide technical service for installations, start-up, user training and maintenance.

STANDARD OPTIONS

Our broad range of standard options provides additional customization.

- Mechanical seals
- Magnetic flow meter
- Non-reverse ratchet motor
- Line reactors
- Opto coupler
- Premium surge protection
- 24-volt remote start relay
- Watervision PC with central integration
- Watervision Cloud with central integration
- 5kW heater
- Paige earth grounding package
- Stainless intake box screens
- Deep wet well (up to 20 ft)
- Discharge drop pipes
- Mechanical joint couplings
- Electronic Butterfly Valve (EBV)
- 5 hp submersible sustain pump
- Auto-flushing wye strainer
- Auto-flushing, suction scanner style filter with stainless steel body – 100/200/300 micron

2 PUMP SKID

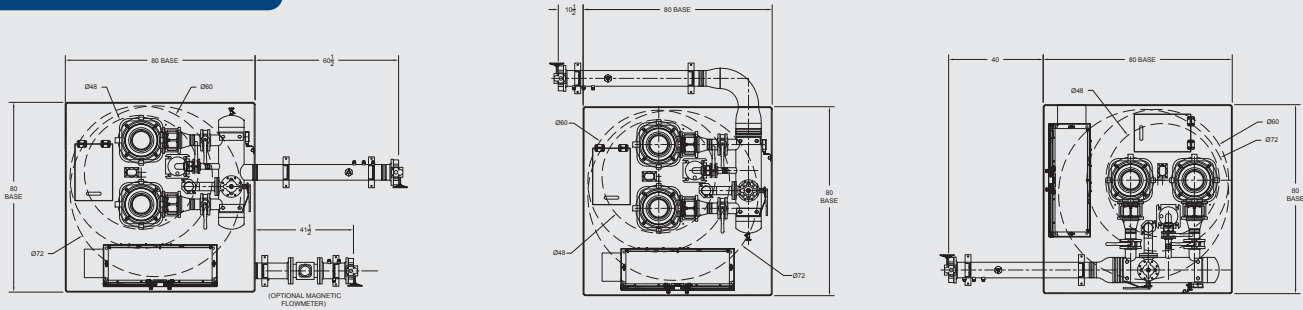

2 PUMP SKID WITH WYE STRAINER

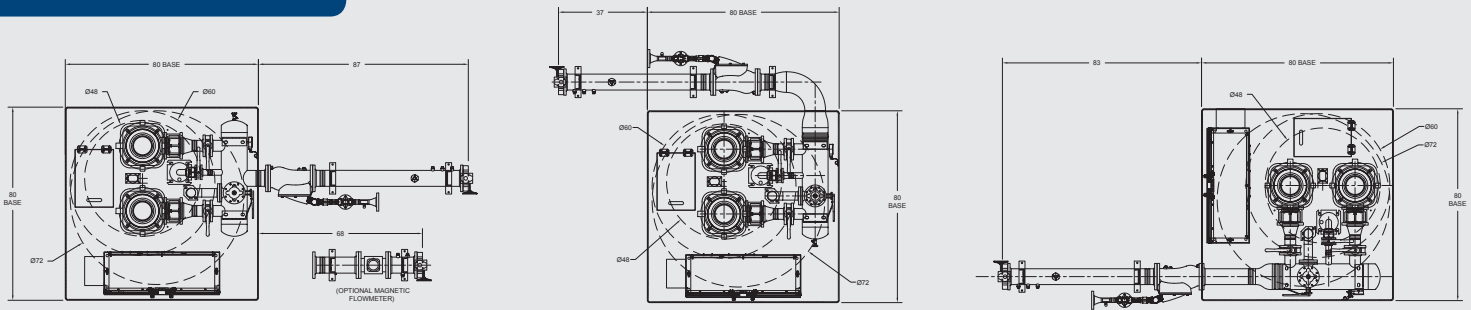

2 PUMP SKID WITH FILTER

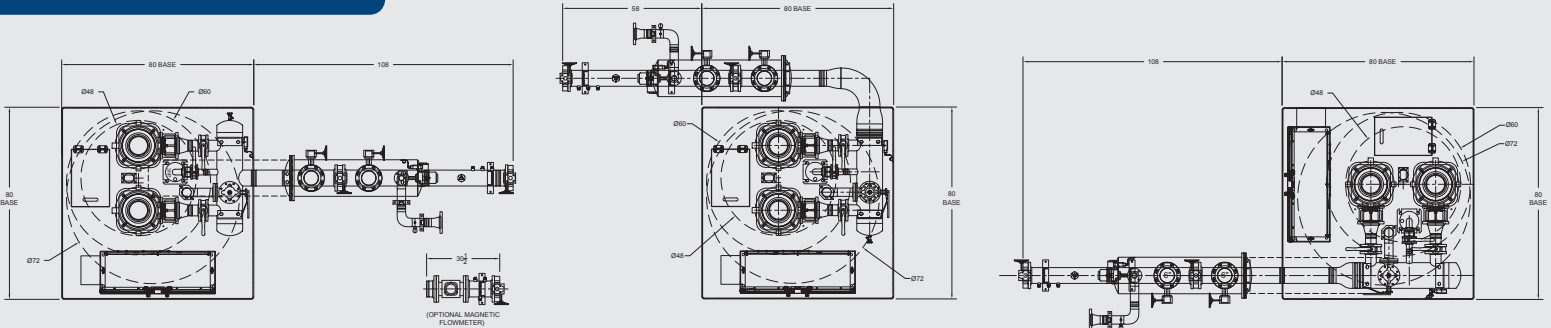

Other standard configurations available



1-800-356-6686 • www.watertronics.com