

Distributed by:

**WATER CONTROLS**  
& PUMP SYSTEMS  
808-876-0132 [www.watercontrols.com](http://www.watercontrols.com)

## WHERE ADVANCED CONTROL MEETS HIGHER FLOW

Setting the standard for 25 years, the WaterMax Series provides a complete line of self-enclosed pumping systems for commercial landscape irrigation. Watertronics' proprietary control software combines with VFD technology to provide highly efficient, precision pumping in a durable, compact design.

### PRECISE PRESSURE REGULATION

WaterMax 7000 Pumping Systems are pre-fabricated, self-contained and incorporate the latest VFD technology to provide smooth, accurate, surge-free and energy efficient performance at varying flow rates. Whether your water source is a lake, pond, or a boosted city supply for large commercial or golf course applications, the 7000 can provide the water and constant pressure desired up to 800 GPM or 140 PSI.

### ADVANCED MONITORING AND CONTROLS

The 7000 control platform options include an industrial grade Programmable Logic Controller with a digital two-line operator interface or a highly intuitive color touchscreen interface. Take your controls to the next level with Watervision 6 remote monitoring technology and access your pump station from any web-enabled device, anytime.

### BUILT TO WITHSTAND THE TEST OF TIME AND TOUGH CONDITIONS

A multi-step coating system of metal preparation, rust-inhibitive baked epoxy primecoat and a two-part UV-resistant baked polyurethane finish produces a long-lasting, durable, and rust-free product.

### DYNAMIC FACTORY TESTING

Every WaterMax system is fully performance tested at field conditions prior to shipment to ensure your pump will perform exactly as promised. All WaterMax Products carry a 1 year limited warranty against defects in materials and workmanship.



- WaterMax 7000 can be customized to exactly meet your requirements through a broad range of options
- Energy-efficient VFD system provides a surge-free soft start
- Pump Service Network (PSN) provides nationwide technical service for installation, start-up, user training and maintenance

- For suction lift, boost or flooded intake applications
- Flows up to 800 GPM
- Maximum combined motor HP 60/15  
Maximum HP duplex pumps, 25/25
- Voltage options 208/3 phase - 240/1 phase -  
240/3 phase - 480/3 phase

[www.watertronics.com](http://www.watertronics.com)

262.367.5000 | 800-356-6686

## STANDARD FEATURES AND BENEFITS

- Watertronics proprietary PLC-based software
- Multi-line digital operator interface display
- Alarms:
  - Low pressure shutdown
  - High pressure shutdown
  - VFD fault shutdown
  - High pump temperature shutdown
  - Motor overload shutdown
  - Phase loss (3 phase only)
- Lightning surge protection
- VFD pressure regulation with surge-free soft starting
- Pressure drop starting
- Stainless steel pressure transducer
- Flow sensor
- NEMA 4 service rated main disconnect panel
- U.L. listed control panel
- Pump construction features include a bronze impeller and a cast iron volute with back pullout design
- Discharge isolation valve
- Priming port for suction lift applications
- Positive prime assembly for lift application
- Engineered, forced air cooled, 14 gauge steel enclosure
- Powder coat or baked polyurethane industrial finish on enclosure & base
- Industrial grade pipe coating system
- Performance run tested prior to shipment

## AVAILABLE OPTIONS

- Color touchscreen operator interface with STN display and time stamping of all alarms
- Medium Green or Sandstone color option
- Watervision 6 remote monitoring software
- Programmable setpoint lake level controls
- Dead-front service disconnect panel
- Suction & discharge drop pipes
- Floating intake suction pipe assembly with foot valve
- Stainless steel or marine-grade aluminum enclosure



 **Lean, Clean and Green.** Lindsay Corporation is committed to developing environmental awareness and implementing sustainable practices to reduce the use of and protect energy, water, and all other resources.



© 2013 Lindsay. All rights reserved. Watertronics and FieldNET are registered trademarks of the Lindsay Corporation. NFPA 70® and National Electric Code® are registered trademarks of NFPA.

WA PRODUCT BRO 2013-6

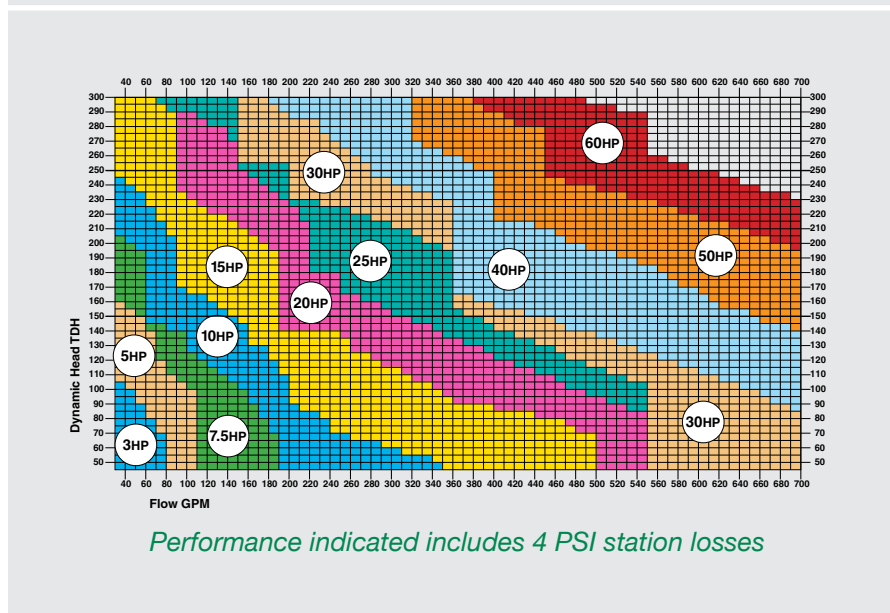
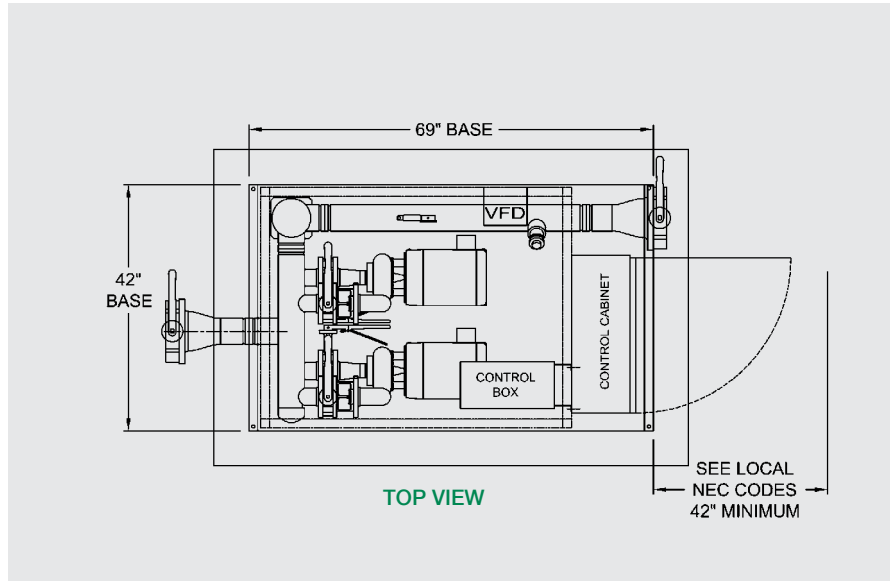

- Thermostatically controlled enclosure heater
- Flow start (booster application only)
- Vandal resistant alarm light
- Internal sound dampening insulation
- In-line filters & strainers
- Back flow preventer (available some models)
- Electronic Butterfly Valve (EBV) back up pressure regulation in the event of a VFD failure
- Submersible turbine pumps
- Stainless steel fasteners



1-800-356-6686 • [www.watertronics.com](http://www.watertronics.com)  
INT'L (+1) 262-367-5000