

NOTCHES AND CUTOUTS

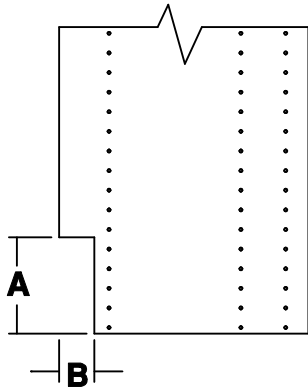

BASE NOTCH "A"

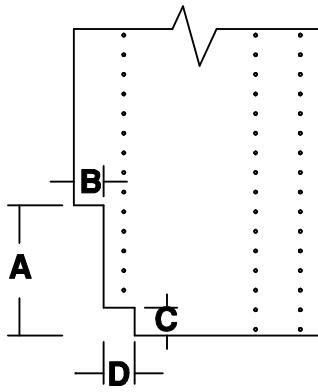

BASE NOTCH "B"

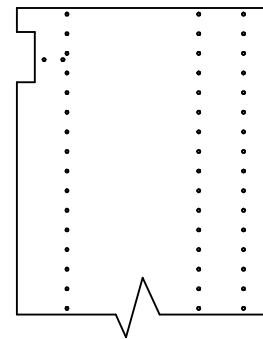

RAIL NOTCH STANDARD

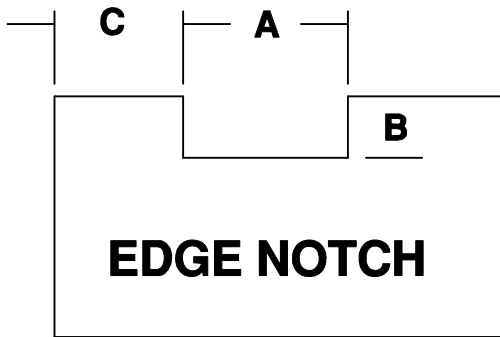

EDGE NOTCH

**A= WIDTH
B= DEPTH
C=START POINT FROM LEFT**

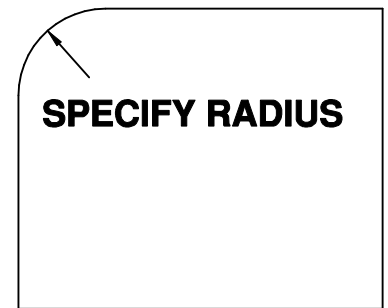

SPECIFY RADIUS

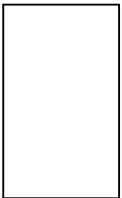

SINGLE SWITCH GROMMET "A"

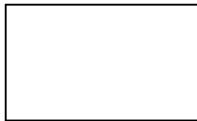

SINGLE SWITCH GROMMET "B"

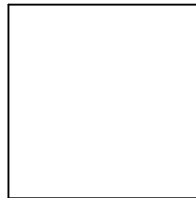

DOUBLE SWITCH GROMMET

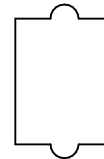

PULL THROUGH SWITCH BOX "A"

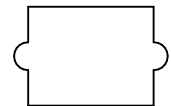

PULL THROUGH SWITCH BOX "B"

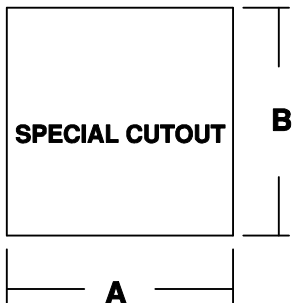

SPECIAL CUTOUT

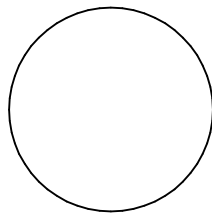

CIRCLE CUTOUT

**SPECIFY: 60MM GROMMET
80MM GROMMET
CUSTOM DIAMETER**

**SPECIFY CUTOUT LOCATIONS AS CENTER LINE:
SHELVES: FROM BACK / LEFT
VERTICAL PANELS: FROM BOTTOM / BACK**

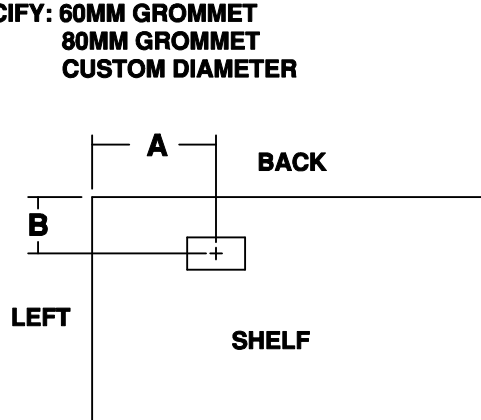

LEFT

SHELF

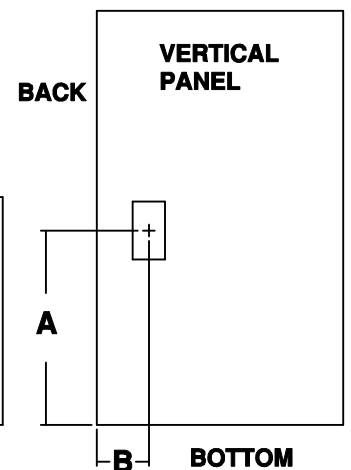

BACK

VERTICAL PANEL

A

B

BOTTOM

**See labor upcharges for special notch, cutout & radius pricing
Base and rail notches no charge**

***Note: Rail notches on VDT & VDT-FL are clearance only, not drilled for brackets**